



MULTI-PROTOCOL CONTROLLER

MULTI-PROTOCOL (MPC) CONTROLLER



The ClimateMaster MultiProtoCol (MPC) Heat Pump controller is designed to allow the integration of ClimateMaster water source heat pump equipment into Direct Digital Control (DDC) systems. The MPC controller has the ability to communicate through a choice of three widely used protocols: BACnet MS/TP, Johnson Controls N2, or Modbus. The protocol of choice for the particular system is selected by simply configuring DIP switches on the ClimateMaster MPC controller. This flexibility allows one controller, the ClimateMaster MPC, to be used in a multitude of buildings which use any of these three common protocols.

The MPC serves as a node of information processing between the ClimateMaster heat pump and the DDC network. See Figure 1 below. The MPC commands the heat pump to heat or cool based upon sensor inputs. The MPC then monitors operation of the heat pump and communicates the operating parameters to the DDC network. The MPC will always work in conjunction with a CXM or DXM controller, which also resides in the ClimateMaster heat pump control box. The MPC has factory pre-loaded application software which allows optimal control of the ClimateMaster heat pump equipment. The MPC can run in stand-alone operation as well as with the DDC network. Therefore, when the ClimateMaster heat pump arrives at the job site with the factory-installed MPC controller, the heat pump is ready to run stand-alone and then can be connected to the DDC network at any time.

UNIT FEATURES

- Multi-Protocol communications provides DDC system flexibility.
- Supports native BACnet MS/TP communications - the ASHRAE standard protocol for interoperability.
- Supports Johnson Controls N2 communications - for integration into Johnson Controls Metasys DDC systems.
- Supports Modbus communications for integration into Modbus DDC networks.
- Four baud rate levels offer flexible communications speeds of 9600, 19.2k, 38.4k, or 76.8k baud.
- Employs a 16-bit bus Hitachi processor with 1024kB RAM and 4096kB Flash Memory which allows, if needed, MPC programs to be upgraded and easily downloaded in the field.
- Removable field wiring connectors for ease of field service.
- Engineered for quality and reliability
- Enables building operators to easily upgrade firmware in the future.

Figure 1: Typical Systems

Water to Air Unit

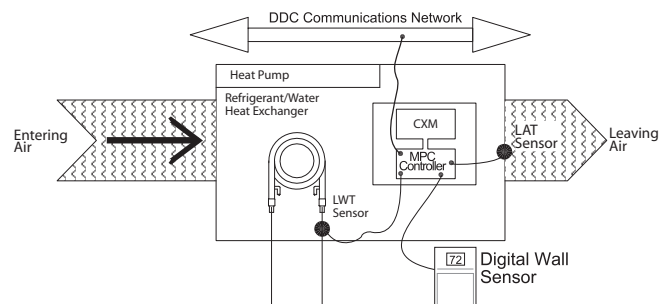

Water to Water Unit

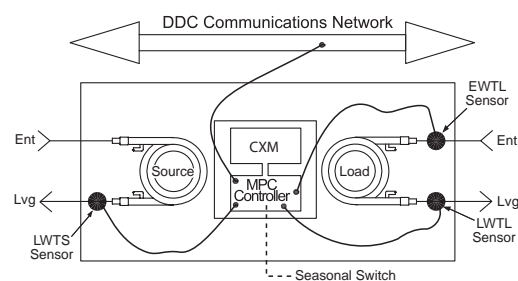

MPC HARDWARE SPECIFICATIONS

	Specifications
Power	24Vac +/-10%, 50 or 60Hz, 15VA max. power consumption
Size	5-1/16" [129mm] width x 5-11/16" [144mm] height x 1-1/2" [38mm] (minimum panel depth)
Housing	Rugged GE C2905HG Cyclopol plastic housing – complies with UL 94 V-O
Environmental	0 to 130 degrees F, (-17.8 to 54.4 C) 10% to 95% non-condensing
Protection	Surge & transient protection circuitry for the power and I/O. Optical isolation for communications port
Processor/Memory	High speed 16-bit Hitachi Processor with 1024kB RAM and 4096kB Flash Memory
LED Indicators	Individual LEDs for digital outputs, power, run, error, transmit, and receive
Compliance	UL916; FCC Part 15, Subpart B, Class A; ICES, Class A; EN55022, Class A IEC61000-6-1; RoHS complaint, WEEE Complaint; BTL listed
I/O Point Count	5 digital outputs (on-board relays rated for 1A resistive at 24Vac) 4 universal inputs (individually jumper-selectable for analog or digital) 1 analog wall sensor port for non-communicating (L-Stat) wall sensors 1 digital wall sensor port for communicating (Rnet) wall sensors
Communications	EIA-485 communications port using twisted pair. A 2 position dip switch allows for manual selection of desired protocol. Available protocols are BACnet MS/TP, Johnson Controls N2, and Modbus. Another 2 position dip switch allows for manual selection of desired baud rate. Available baud rates are 9600, 19.2k, 38.4k, and 76.8k.
Addressing	2 rotary address switches are provided for setting the individual controller's network address
Mounting Hole Dimensions	Two mounting holes center line as below with 5-9/16 " [141mm] height spacing. Factory Mounted.

ASW SENSORS

ASW Sensors are wall-mounted temperature sensors for use with the ClimateMaster MPC controller. The sensors are available in three different models to allow for maximum application flexibility. The low profile ASW wall sensors are attractive and easily mounted. When combined with the ClimateMaster MPC, the ASW wall sensors offer a multitude of features.

UNIT FEATURES

- Attractive, low profile design
- Accurate room temperature sensing for complete comfort
- Easy to use analog connections
- LED for occupied status and fault indicator (ASW14 & ASW15)

Figure 2: ASW15 sensor shown



Local setpoint adjustment (ASW14 & ASW15)

Digital room temperature display (ASW15)

LED for Occupied status and Fault indicator (ASW14 & ASW15)

Local heat pump lockout/reset via the Override push-button (ASW14 & ASW15)

Model	Description	Display
ASW13	Sensor Only	None
ASW14	Sensor with Local Temperature Adjustment and Override	Slider for Setpoint Adjust, LED for Occupied Status
ASW15	Sensor with Local Temperature and Setpoint Adjustment and Override	Digital LCD Display Shows Space Temperature, Local Setpoints, Occupancy Status and Heat Pump Status



7300 S.W. 44th Street
Oklahoma City, OK 73179
Phone: 405-745-6000
Fax: 405-745-6058
climatemaster.com

ClimateMaster works continually to improve its products. As a result, the design and specifications of each product at the time for order may be changed without notice and may not be as described herein. Please contact ClimateMaster's Customer Service Department at 1-405-745-6000 for specific information on the current design and specifications. Statements and other information contained herein are not express warranties and do not form the basis of any bargain between the parties, but are merely ClimateMaster's opinion or commendation of its products.