



**AHWG Remote Mount
Hot Water
Generator Module
for TTP Series
Outdoor Split Unit**

Installation, Operation &
Maintenance Instructions
97B0080N01
Rev.: 27 July, 2010B

Table of Contents

| | | | |
|---|-----|----------------------------|------|
| Model Nomenclature Example | 3 | Wiring and Electrical Data | 9-10 |
| Description and Installation Examples | 4 | Warranty | 11 |
| Installation and Operating Instructions | 5-8 | Revision History | 12 |

This page was intentionally left blank.

Model Nomenclature: for Remote Hot Water Generator

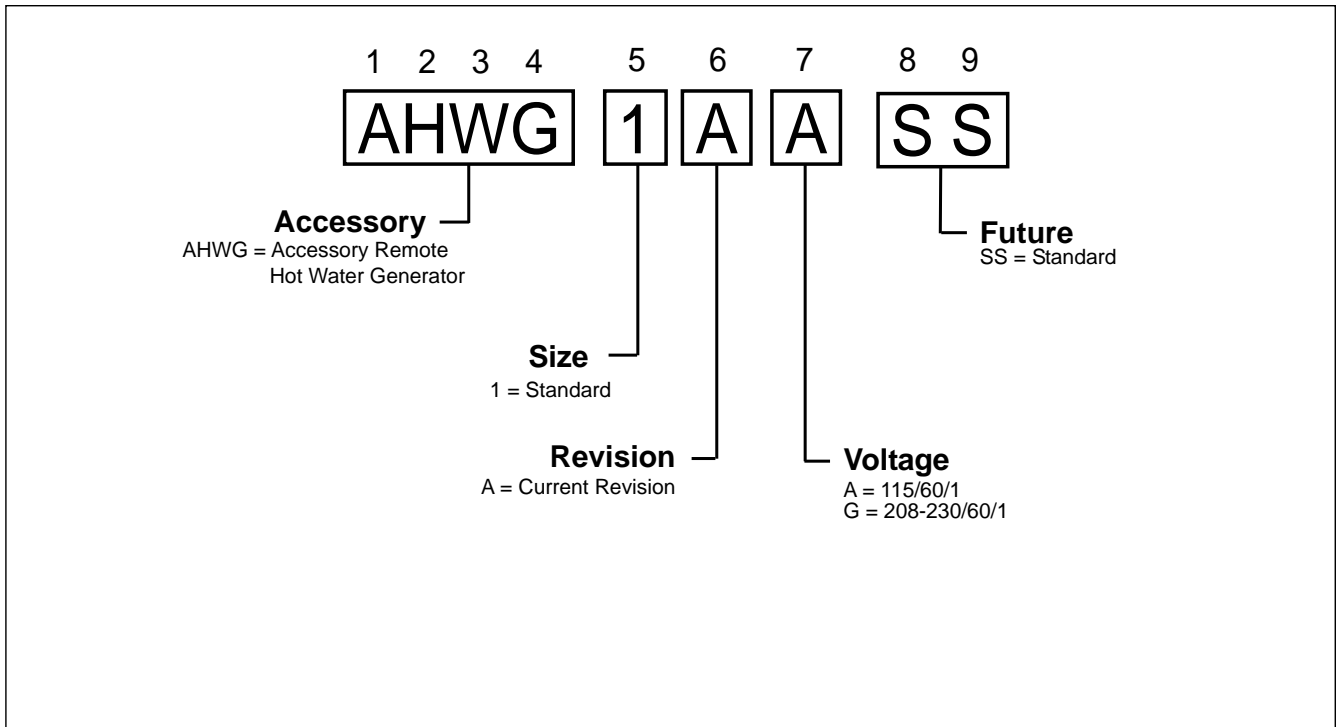

Hot Water Generator Module For Outdoor Compressor Section

General Information

The HWG Module consists of an all-copper, vented double-wall heat exchanger and a water-cooled bronze water circulating pump. The pump is controlled by a microprocessor in the HWG module. Power for the pump is provided from a remote 115 or 230 vac power source.

The HWG (Hot Water Generator) or desuperheater option provides considerable operating cost savings by utilizing excess heat energy from the heat pump to help satisfy domestic hot water requirements. The HWG may be active throughout the year, providing virtually free hot water when the heat pump operates in the cooling mode or hot water at the COP of the heat pump during operation in the heating mode. Actual HWG water heating capacities are provided in the appropriate heat pump performance data.

The temperature set point of the HWG is field selectable to 125°F or 150°F. The 150°F set point allows more heat storage from the HWG. For example, consider the amount of heat that can be generated by the HWG when using the 125°F set point, versus the amount of heat that can be generated by the HWG when using the 150°F set point.

In a typical 50 gallon two-element electric water heater the lower element should be turned down to 100°F, or the lowest setting, to get the most from the HWG. The tank will eventually stratify so that the lower 80% of the tank, or 40 gallons, becomes 100°F (controlled by the lower element). The upper 20% of the tank, or 10 gallons, will be maintained at 125°F (controlled by the upper element).

Using a 125°F set point, the HWG can heat the lower 40 gallons of water from 100°F to 125°F, providing up to 8,330 btu's of heat. Using the 150°F set point, the HWG can heat the same 40 gallons of water from 100°F to 150°F and the remaining 10 gallons of water from 125°F to 150°F, providing a total of up to 18,743 btu's of heat, or more than twice as much heat as when using the 125°F set point.

This example ignored standby losses of the tank. When those losses are considered the additional savings are even greater.

Electric water heaters are recommended. If a gas, propane, or oil water heater is used, a second preheat tank must be installed (Figure 2). If the electric water heater has only a single center element, the dual tank system is recommended to insure a usable entering water temperature for the HWG.

Typically a single tank of at least 52 gallons (235 liters) is used to limit installation costs and space. However, a dual tank, as shown in Figure 2, is the most efficient system, providing the maximum storage and temperate source water to the HWG.

It is always advisable to use water softening equipment on domestic water systems to reduce the scaling potential and lengthen equipment life. In extreme water conditions, it may be necessary to avoid the use of the HWG option since the

potential cost of frequent maintenance may offset or exceed any savings. Consult unit IOM for scaling potential tests.

Figure 1: Typical HWG Installation (Outdoor Compressor Section)

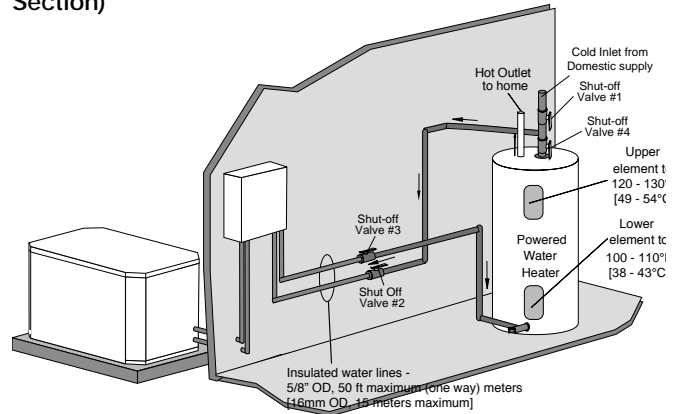
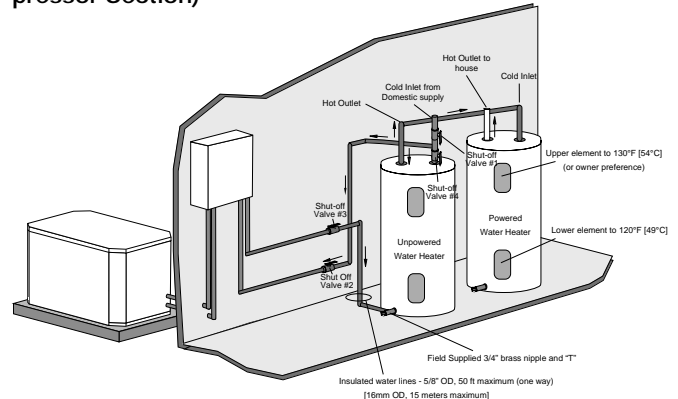

Figure 2: HWG Double Tank Installation (Outdoor Compressor Section)



Hot Water Generator Module Refrigeration Installation For Outdoor Compressor Section Only

Location/Mounting

The HWG module should be mounted indoors and as close to the heat pump outdoor section as possible, in order to minimize the length of refrigerant run. It is recommended that the HWG module be mounted above the system compressor in order to promote proper oil movement and drain-down.

This means that the HWG module can be wall mounted in any orientation except for stubs up. Mounting should be accomplished by fastening the HWG module cabinet to the wall or other selected vertical surface. Mounting holes are provided at the rear of the unit. Any fastener suitable for supporting a 12 pound [5.4] vertical load is acceptable.

SPECIAL NOTE: The selected mounting location and orientation must allow the circulator pump to be positioned with the motor shaft horizontal. **DO NOT install the Heat Recovery Unit flat on its back.**

Refrigerant Line Installation

Before starting the installation into the refrigerant circuit, inspect and note the condition and performance of the heat pump. Disconnect power to the heat pump outdoor unit. Any system deficiencies must be corrected prior to installing the HWG module. Addition of the HWG will not correct system problems. Record the suction and discharge pressures and compressor amperage draw. These may be used for comparison with system operation after the refrigerant line installation is complete.

Install the Add-On HWG Kit

Locate the HWG as close to the water heater as possible. Install the lineset to the desuperheater valves in the outdoor compressor section and the refrigerant line connections on the HWG. Maximum length should be 30 feet one way. Evacuate the lineset to 500 microns through the hot gas valves in the outdoor unit. Open the HWG valves in the compressor section up fully (and close the desuperheater bypass valve). See Figures 3a through 3d. Check the lineset for leaks. Verify that lineset tubing is completely insulated with a minimum 1/2" thick closed cell and painted to prevent deterioration of the insulation due to ultra violet light and weather. Make the connections with high temperature solder or brazing rod. The recommended line size is dependent on the one way distance between the Hot Water Generator and the compressor; and the size of the system. Use Figure 4 as a guideline.

NOTICE! Make sure the compressor discharge line is connected to the "Hot Gas In" stub on the Hot Water Generator.

⚠ WARNING! ⚠

WARNING! The HWG module is an appliance that operates in conjunction with the heat pump system, the hot water system and the electrical system. Installation should only be performed by skilled technicians with appropriate training and experience. The installation must be in compliance with local codes and ordinances. Local plumbing and electrical building codes take precedence over instructions contained herein. The Manufacturer accepts no liability for equipment damaged and/or personal injury arising from improper installation of the HWG module.

⚠ CAUTION! ⚠

CAUTION! The HWG module must be installed in an area that is not subject to freezing temperatures.

⚠ CAUTION! ⚠

CAUTION! Locate Refrigerant lines to avoid accidental damage by lawnmowers or children.

Hot Water Generator Module Installation

Outdoor Compressor Section Only

Figure 3a: Outdoor Compressor Section HWG Installation

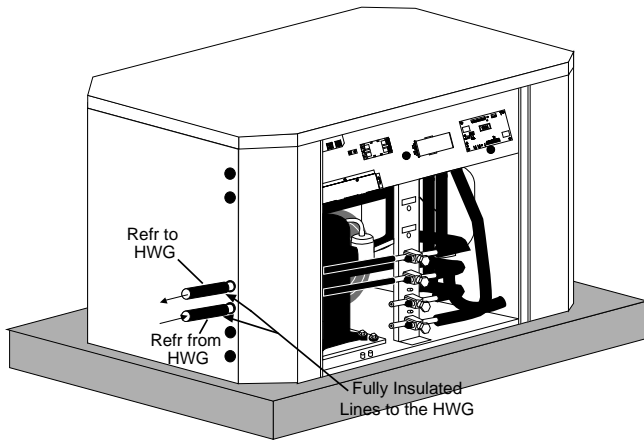

Figure 3c: HWG Service Valves

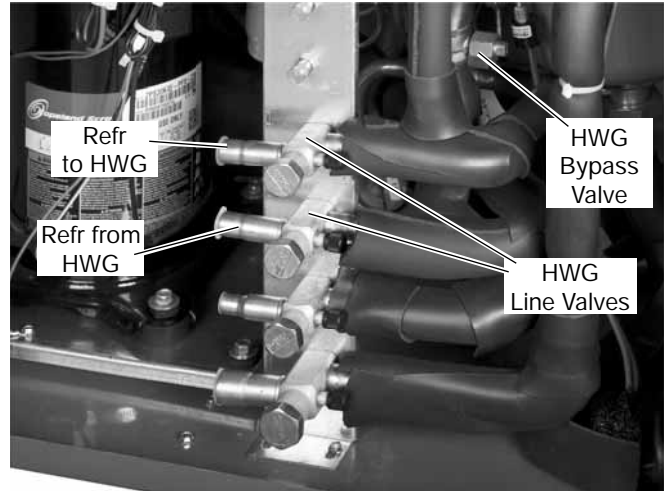

Figure 3b: Remote HWG Module

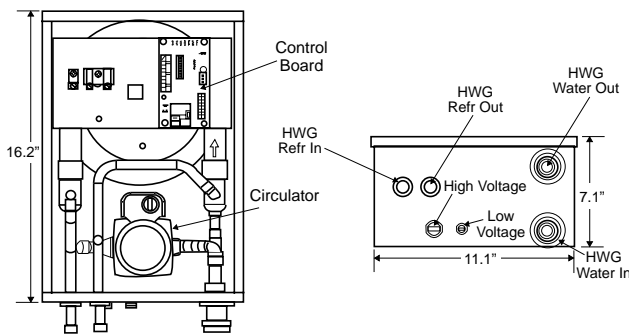
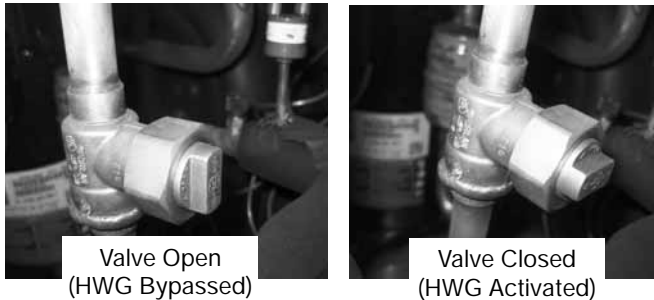

Figure 4: HWG Refrigerant Line Sizing

| Capacity | Line Set Size | | |
|----------|---------------------|---------------------|---------------------|
| | 1/2" OD | 5/8" OD | 3/4" OD |
| 2 Ton | Up to 16 ft. [4.9m] | Up to 30 ft. [9.1m] | N/A |
| 3 Ton | Up to 9 ft. [2.7m] | Up to 25 ft. [7.6m] | Up to 30 ft. [9.1m] |
| 4 Ton | Up to 5 ft. [1.5m] | Up to 13 ft. [4.0m] | Up to 30 ft. [9.1m] |
| 5 Ton | N/A | Up to 9 ft. [2.7m] | Up to 25 ft. [7.6m] |

Figure 3d: HWG Bypass Valve



As a guideline add 1.0 oz. of refrigerant for the heat exchanger plus 1.0 oz. for each 10 ft of 1/2" OD refrigerant line, if the weighed charge method is used (28g for the heat exchanger plus 9g per meter of 1/2" OD refrigerant line).

Hot Water Generator Module

Installation

The HWG is controlled by two sensors and a microprocessor control. One sensor is located on the compressor discharge line to sense the discharge refrigerant temperature. The other sensor is located on the HWG heat exchanger's "Water In" line to sense the potable water temperature.

⚠ WARNING! ⚠

WARNING! UNDER NO CIRCUMSTANCES SHOULD THE SENSORS BE DISCONNECTED OR REMOVED AS FULL LOAD CONDITIONS CAN DRIVE HOT WATER TANK TEMPERATURES FAR ABOVE SAFE TEMPERATURE LEVELS IF SENSORS HAVE BEEN DISCONNECTED OR REMOVED.

The microprocessor control monitors the refrigerant and water temperatures to determine when to operate the HWG. The HWG will operate any time the refrigerant temperature is sufficiently above the water temperature. Once the HWG has satisfied the water heating demand during a heat pump run cycle, the controller will cycle the pump at regular intervals to determine if an additional HWG cycle can be utilized. The microprocessor control includes 3 DIP switches, SW10 (HWG PUMP TEST), SW11 (HWG TEMP), and SW12 (HWG STATUS).

SW10 HWG PUMP TEST. When this switch is in the "ON" position, the HWG pump is forced to operate even if there is no call for the HWG. This mode may be beneficial to assist in purging the system of air during initial start up. When SW10 is in the "OFF" position, the HWG will operate normally. This switch is shipped from the factory in the "OFF" (normal) position. **NOTE:** If left in the "On" position for 5 minutes, the pump control will revert to normal operation.

SW11 HWG TEMP. The control setpoint of the HWG can be set to either of two temperatures, 125°F or 150°F. When SW11 is in the "ON" position the HWG setpoint is 150°F. When SW11 is in the "OFF" position the HWG setpoint is

⚠ WARNING! ⚠

WARNING! USING A 150°F SETPOINT ON THE HWG WILL RESULT IN WATER TEMPERATURES SUFFICIENT TO CAUSE SEVERE PHYSICAL INJURY IN THE FORM OF SCALDING OR BURNS, EVEN WHEN THE HOT WATER TANK TEMPERATURE SETTING IS VISIBLY SET BELOW 150°F. THE 150°F HWG SETPOINT MUST ONLY BE USED ON SYSTEMS THAT EMPLOY AN APPROVED ANTI-SCALD VALVE (CLIMATEMASTER PART NUMBER AVAS4) AT THE HOT WATER STORAGE TANK WITH SUCH VALVE PROPERLY SET TO CONTROL WATER TEMPERATURES DISTRIBUTED TO ALL HOT WATER OUTLETS AT A TEMPERATURE LEVEL THAT PREVENTS SCALDING OR BURNS!

ANTI-SCALD VALVE PIPING CONNECTIONS

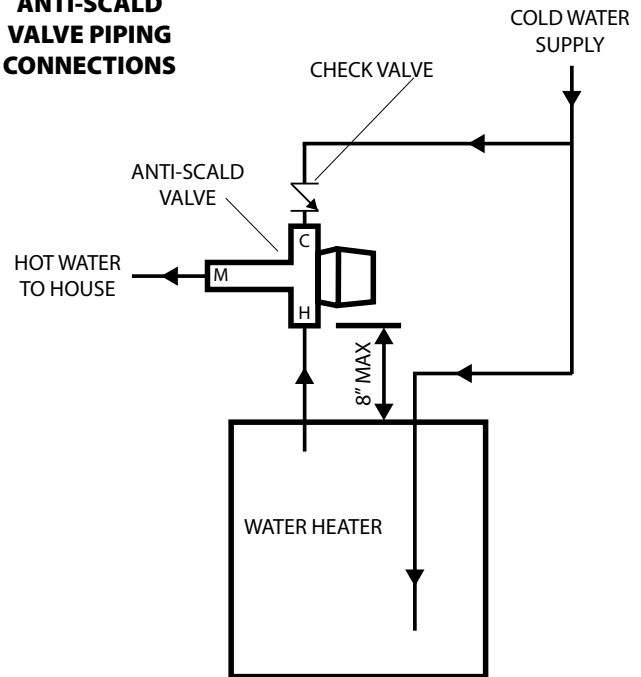

125°F. This switch is shipped from the factory in the "OFF" (125°F) position.

SW12 HWG STATUS. This switch controls operation of the HWG. When SW12 is in the "ON" position the HWG is disabled and will not operate. When SW12 is in the "OFF" position the HWG is in the enabled mode and will operate normally. This switch is shipped from the factory in the "ON" (disabled) position. **CAUTION: DO NOT PLACE THIS SWITCH IN THE ENABLED POSITION UNTIL THE HWG PIPING IS CONNECTED, FILLED WITH WATER, AND PURGED OR PUMP DAMAGE WILL OCCUR.**

When the control is powered and the HWG pump output is not active, the status LED (AN1) will be "On". When the HWG pump output is active for water temperature sampling or HWG operation, the status LED will slowly flash (On 1 second, Off 1 second).

If the control has detected a fault, the status LED will flash a numeric fault code as follows:

| | |
|-----------------------------------|-----------|
| Hot Water Sensor Fault | 1 flash |
| Compressor Discharge sensor fault | 2 flashes |
| High Water Temperature (>160°F) | 3 flashes |
| Control Logic Error | 4 flashes |

Fault code flashes have a duration of 0.4 seconds with a 3 second pause between fault codes. For example, a "Compressor Discharge sensor fault" will be four flashes 0.4 seconds long, then a 3 second pause, then four flashes again, etc.

Hot Water Generator Module - Domestic Water Installation

⚠ WARNING! ⚠

Warning! Use extreme caution when working around the microprocessor control as it contains line voltage connections that presents a shock hazard that can cause severe injury or death!

The heat pump, water piping, HWG, and hot water tank should be located where the ambient temperature does not fall below 50°F [10°C]. Keep water piping lengths at a minimum. DO NOT use a one way length greater than 50 ft. (one way) [15 m].

All installations must be in accordance with local codes. The installer is responsible for knowing the local requirements, and for performing the installation accordingly. DO NOT connect the pump wiring until "Initial Start-Up" section, below. Powering the pump before all installation steps are completed may damage the pump.

Water Tank Preparation

1. Turn off power or fuel supply to the hot water tank.
2. Connect a hose to the drain valve on the water tank.
3. Shut off the cold water supply to the water tank.
4. Open the drain valve and open the pressure relief valve or a hot water faucet to drain tank.
5. When using an existing tank, it should be flushed with cold water after it is drained until the water leaving the drain hose is clear and free of sediment.
6. Close all valves and remove the drain hose.
7. Install HWG water piping.

HWG Water Piping

1. Using at least 5/8" [16mm] O.D. copper, route and install the water piping and valves as shown in Figures 1 or 2. Install an approved anti-scald valve if the 150°F HWG setpoint is or will be selected. An appropriate method must be employed to purge air from the HWG piping. This may be accomplished by flushing water through the HWG (as In Figures 1 and 2) or by installing an air vent at the high point of the HWG piping system.
2. Insulate all HWG water piping with no less than 3/8" [10mm] wall closed cell insulation.
3. Open both shut off valves and make sure the tank drain valve is closed.

Water Tank Refill

1. Close valve #4. Ensure that the HWG valves (valves #2 and #3) are open. Open the cold water supply (valve #1) to fill the tank through the HWG piping. This will purge air from the HWG piping.
2. Open a hot water faucet to vent air from the system until water flows from faucet; turn off faucet. Open valve #4.
3. Depress the hot water tank pressure relief valve handle to ensure that there is no air remaining in the tank.
4. Inspect all work for leaks.
5. Before restoring power or fuel supply to the water heater,

- adjust the temperature setting on the tank thermostat(s) to insure maximum utilization of the heat available from the refrigeration system and conserve the most energy. On tanks with both upper and lower elements and thermostats, the lower element should be turned down to 100°F [38°C] or the lowest setting; the upper element should be adjusted to 120-130°F [49-54°C]. Depending upon the specific needs of the customer, you may want to adjust the upper element differently. On tanks with a single thermostat, a preheat tank should be used (Fig 2).
6. Replace access cover(s) and restore power or fuel supply.

Initial Start-Up

1. Make sure all valves in the HWG water circuit are fully open.
2. Make electrical connections (power and low voltage) as shown on the HWG wiring diagram. Example wiring diagrams and an electrical data table are included in this document (See Figures 5-8).
3. Turn the heat pump power and remote HWG power "off" and switch dip switch SW12 on the HWG controller to the "off" (enabled) position to activate the HWG.
4. The HWG pump should not run if the compressor is not running.
5. The temperature difference between the water entering and leaving the HWG should be approximately 5-10 °F [3-6 °C].
6. Allow the unit to operate for 20 to 30 minutes insure that it is functioning properly.
7. Always turn dip switch SW12 on the HWG controller to the "on" (disabled) position to deactivate the HWG when servicing the outdoor compressor section.

HWG Water Piping Size and Length

| Unit Nominal Tonnage | Nominal HWG Flow (gpm) | 1/2" Copper (max length*) | 3/4" Copper (max length*) |
|----------------------|------------------------|---------------------------|---------------------------|
| 1.5 | 0.6 | 50 | - |
| 2.0 | 0.8 | 50 | - |
| 2.5 | 1.0 | 50 | - |
| 3.0 | 1.2 | 50 | - |
| 3.5 | 1.4 | 50 | - |
| 4.0 | 1.6 | 45 | 50 |
| 5.0 | 2.0 | 25 | 50 |
| 6.0 | 2.4 | 10 | 50 |

*Maximum length is equivalent length (in feet) one way of type L copper.

Electrical - Wiring

Figure 5: HWG Module Wiring 230 Volt

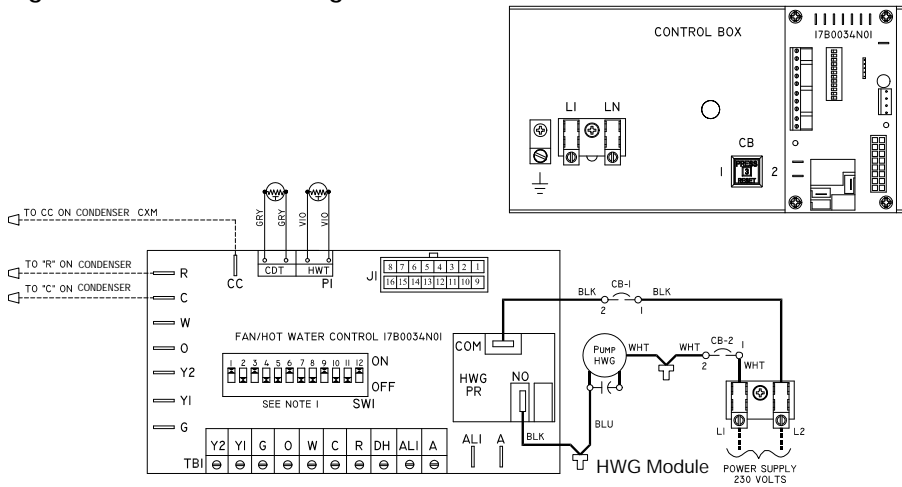
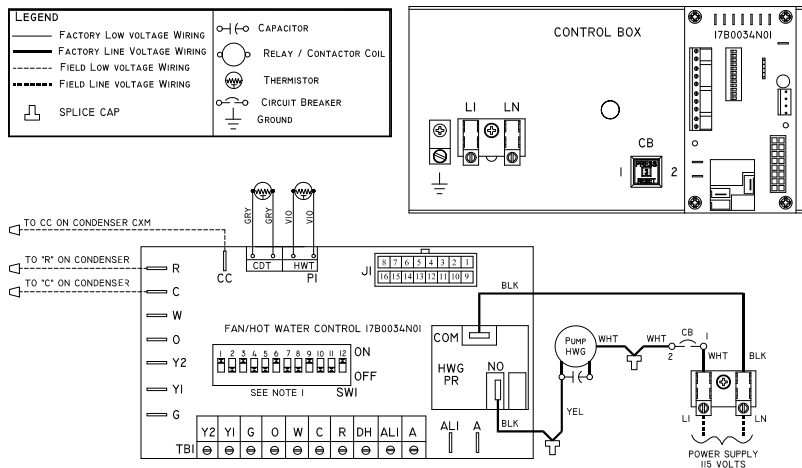

Figure 6: HWG Module Wiring 115 volt



HWG Module Wiring - For "Outdoor" Compressor Section
The HWG module should be wired to a power supply as shown in Figure 5 or 6. A safety disconnect should be installed at the HWG module as required by code to allow servicing of the module. DO NOT energize the pump until all HWG piping is completed and air is purged from the water piping to avoid running the pump "dry".

Figure 7: HWG Module Electrical Data

| HWG Module | Voltage | Pump FLA | Total FLA | Min Circuit Amps | Min Wire Size |
|------------|--------------|----------|-----------|------------------|---------------|
| AHWG1AASS | 115/60/1 | 0.52 | 0.52 | 1.20 | 14 ga. |
| AHWG1AGSS | 208/230/60/1 | 0.40 | 0.40 | 0.90 | 14 ga. |

⚠ WARNING! ⚠

WARNING! To avoid possible injury or death due to electrical shock, open the power supply disconnect switch and secure it in an open position during installation.

⚠ CAUTION! ⚠

CAUTION! Use only copper conductors for field installed electrical wiring. Unit terminals are not designed to accept other types of conductors.

Electrical - Wiring

Figure 8: Low Voltage Field Wiring

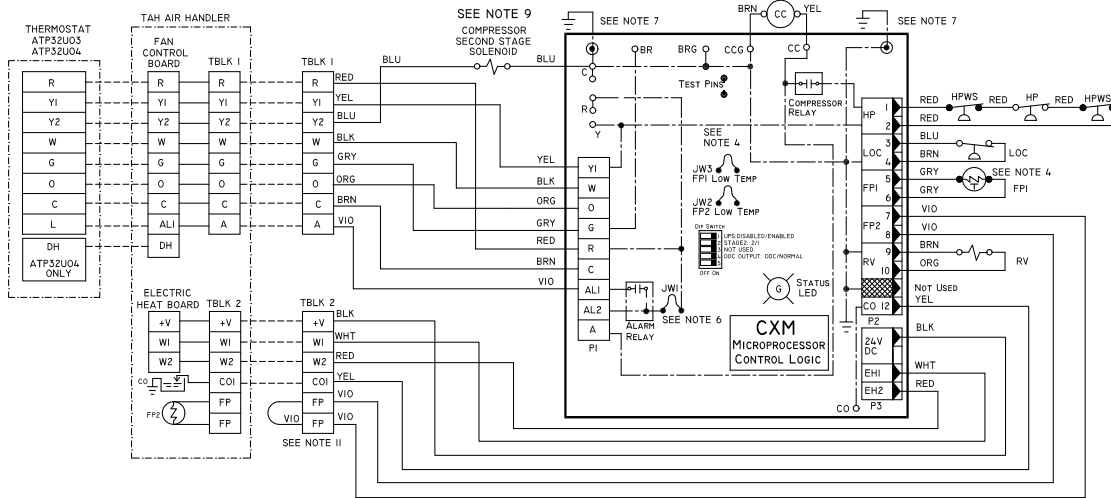

⚠ WARNING! ⚠
WARNING! To avoid possible injury or death due to electrical shock, open the power supply disconnect switch and secure it in an open position during installation.

⚠ CAUTION! ⚠
CAUTION! Use only copper conductors for field installed electrical wiring. Unit terminals are not designed to accept other types of conductors.

Warranty



CLIMATE MASTER, INC. LIMITED EXPRESS WARRANTY/LIMITATION OF REMEDIES AND LIABILITY FOR RESIDENTIAL CLASS PRODUCTS WITH LABOR ALLOWANCE

It is expressly understood that unless a statement is specifically identified as a warranty, statements made by Climate Master, Inc. a Delaware corporation, ("CM") or its representatives, relating to CM's products, whether oral, written or contained in any sales literature, catalog or agreement, are not express warranties and do not form a part of the basis of the bargain, but are merely CM's opinion or commendation of CM's products. **EXCEPT AS SPECIFICALLY SET FORTH HEREIN, THERE IS NO EXPRESS WARRANTY AS TO ANY OF CM'S PRODUCTS. CM MAKES NO WARRANTY AGAINST LATENT DEFECTS. CM MAKES NO WARRANTY OF MERCHANTABILITY OF THE GOODS OR OF THE FITNESS OF THE GOODS FOR ANY PARTICULAR PURPOSE.**

GRANT OF LIMITED EXPRESS WARRANTY

CM warrants its Residential Class products, purchased and retained in the United States of America and Canada, to be free from defects in material and workmanship under normal use and maintenance as follows: (1) Air conditioning, heating and/or heat pump units built or sold by CM ("CM Units") for ten (10) years from the Warranty Inception Date (as defined below); (2) Thermostats, auxiliary electric heaters and geothermal pumping modules built or sold by CM, when installed with CM Units, for ten (10) years from the Warranty Inception Date (as defined below); and (3) Other accessories and parts built or sold by CM, when installed with CM Units, for one (1) year from the date of shipment from CM. The "Warranty Inception Date" shall be the date of original unit installation, or six (6) months from date of unit shipment from CM, whichever comes first.

To make a claim under this warranty, parts must be returned to CM in Oklahoma City, Oklahoma, freight prepaid, no later than ninety (90) days after the date of the failure of the part; if CM determines the part to be defective and within CM's Limited Express Warranty, CM shall, when such part has been either replaced or repaired, return such to a factory recognized distributor, dealer or service organization, F.O.B. CM, Oklahoma City, Oklahoma, freight prepaid. The warranty on any part repaired or replaced under warranty expires at the end of the original warranty period.

This Limited Express Warranty shall cover the labor incurred by CM authorized service personnel in connection with the installation of a new or repaired warranty part that is covered by this Limited Express Warranty; only to the extent specifically set forth in the then existing labor allowance schedule provided by CM's Warranty Department and only as follows: (1) CM Units for five (5) years from the Warranty Inception Date; (2) Thermostats, auxiliary electric heaters and geothermal pumping modules built or sold by CM, when installed with CM Units, for five (5) years from the Warranty Inception Date. Actual Labor costs are not covered by this Limited Express Warranty to the extent they exceed the amount allowed under said allowance schedule, they are not specifically provided for in said allowance schedule, they are not the result of work performed by CM authorized service personnel, they are incurred in connection with a part not covered by this Limited Express Warranty, or they are incurred more than the time periods set forth in this paragraph after the Warranty Inception Date.

This warranty does not cover and does not apply to: (1) Air filters, fuses, refrigerant, fluids, oil; (2) Products relocated after initial installation; (3) Any portion or component of any system that is not supplied by CM, regardless of the cause of the failure of such portion or component; (4) Products on which the unit identification tags or labels have been removed or defaced; (5) Products on which payment to CM, or to the owner's seller or insulating contractor, is in default; (6) Products subjected to improper or inadequate installation, maintenance, repair, wiring or voltage conditions; (7) Products subjected to accident, misuse, negligence, abuse, fire, flood, lightning, unauthorized alteration, misapplication, contaminated or corrosive air or liquid supply, operation at abnormal air or liquid temperatures or flow rates, or opening of the refrigerant circuit by unqualified personnel; (8) Mold, fungus or bacteria damage; (9) Corrosion or abrasion of the product; (10) Products supplied by others; (11) Products which have been operated in a manner contrary to CM's printed instructions; (12) Products which have insufficient performance as a result of improper system design or improper application, installation, or use of CM's products; or (13) Electricity or fuel costs, or any increases or unrealized savings in same, for any reason whatsoever.

This Limited Express Warranty provides the limited labor allowance coverage as set forth above. Otherwise, CM is not responsible for: (1) The costs of any fluids, refrigerant or system components supplied by others, or associated labor to repair or replace the same, which is incurred as a result of a defective part covered by CM's Limited Express Warranty; (2) The costs of labor, refrigerant, materials or service incurred in diagnosis and removal of the defective part, or in obtaining and replacing the new or repaired part; (3) Transportation costs of the defective part from the installation site to CM, or of the return of that part if not covered by CM's Limited Express Warranty; or (4) The costs of normal maintenance.

This Limited Express Warranty applies to CM Residential Class products ordered from CM on or after May 1, 2010 (this would generally include CM Units with serial numbers beginning with "N118" and higher), and is not retroactive to any products ordered from CM prior to May 1, 2010 (this would generally include CM Units with serial numbers beginning with "N117" and lower). If you are unsure if this Limited Express Warranty applies to the product you have purchased, contact CM at the phone number or address reflected below.

Limitation: This Limited Express Warranty is given in lieu of all other warranties. If, notwithstanding the disclaimers contained herein, it is determined that other warranties exist, any such express warranty, including without limitation any express warranties or any implied warranties of fitness for particular purpose and merchantability, shall be limited to the duration of the Limited Express Warranty.

LIMITATION OF REMEDIES

In the event of a breach of the Limited Express Warranty, CM will only be obligated at CM's option to repair the failed part or unit, or to furnish a new or rebuilt part or unit in exchange for the part or unit which has failed. If after written notice to CM's factory in Oklahoma City, Oklahoma of each defect, malfunction or other failure, and a reasonable number of attempts by CM to correct the defect, malfunction or other failure, and the remedy fails of its essential purpose, CM shall refund the purchase price paid to CM in exchange for the return of the sold good(s). Said refund shall be the maximum liability of CM. **THIS REMEDY IS THE SOLE AND EXCLUSIVE REMEDY OF THE BUYER OR PURCHASER AGAINST CM FOR BREACH OF CONTRACT, FOR THE BREACH OF ANY WARRANTY OR FOR CM'S NEGLIGENCE OR IN STRICT LIABILITY.**

LIMITATION OF LIABILITY

CM shall have no liability for any damages if CM's performance is delayed for any reason or is prevented to any extent by any event such as, but not limited to: any war, civil unrest, government restrictions or restraints, strikes, or work stoppages, fire, flood, accident, shortages of transportation, fuel, material, or labor, acts of God or any other reason beyond the sole control of CM. **CM EXPRESSLY DISCLAIMS AND EXCLUDES ANY LIABILITY FOR CONSEQUENTIAL OR INCIDENTAL DAMAGE IN CONTRACT, FOR BREACH OF ANY EXPRESS OR IMPLIED WARRANTY, OR IN TORT, WHETHER FOR CM'S NEGLIGENCE OR AS STRICT LIABILITY.**

OBTAINING WARRANTY PERFORMANCE

Normally, the dealer or service organization who installed the products will provide warranty performance for the owner. Should the installer be unavailable, contact any CM recognized distributor, dealer or service organization. If assistance is required in obtaining warranty performance, write or call:

Climate Master, Inc. • Customer Service • 7300 SW 44th Street • Oklahoma City, Oklahoma 73179 • (405) 745-6000 • e-service@climatemaster.com

NOTE: Some states or Canadian provinces do not allow limitations on how long an implied warranty lasts, or the limitation or exclusions of consequential or incidental damages, so the foregoing exclusions and limitations may not apply to you. This warranty gives you specific legal rights, and you may also have other rights which vary from state to state and from Canadian province to Canadian province.

Please refer to the CM Installation, Operation and Maintenance Manual for operating and maintenance instructions.

Rev: 47/0
Part No: RPS1

Revision History

| Date | Page # | Description |
|---------------|--------|---|
| 27 July, 10 | 10 | Low Voltage Field Wiring Figure Updated |
| 4 May, 10 | 11 | New Warranty Update |
| 30 April, 10 | 4 | HWG Piping Drawings Revised |
| 20 Oct., 09 | All | Verbiage Updates |
| 19 August, 09 | All | First Published |



7300 S.W. 44th Street
Oklahoma City, OK 73179
Phone: 405-745-6000
Fax: 405-745-6058
climatemaster.com



97B0080N01

ClimateMaster works continually to improve its products. As a result, the design and specifications of each product at the time for order may be changed without notice and may not be as described herein. Please contact ClimateMaster's Customer Service Department at 1-405-745-6000 for specific information on the current design and specifications. Statements and other information contained herein are not express warranties and do not form the basis of any bargain between the parties, but are merely ClimateMaster's opinion or commendation of its products.

The management system governing the manufacture of ClimateMaster's products is ISO 9001:2000 certified.