



Tranquility 27[®] (TT) Series

TWO-STAGE
HORIZONTAL VERTICAL AND DOWNFLOW
EARTHPURE[®] SYSTEMS SIZES 026-072 [7.0-19.3 kW]

Table of Contents

What's New With The Tranquility 27 [®] ?	51	Dimensions — Vertical Downflow	74
Design Features	52	Dimensions — Horizontal	76
Unit Model Key	54	Electrical Data	78
About AHRI/ISO/ASHRAE 13256-1	55	Standard Electrical Wiring Diagrams	79
AHRI/ISO/ASHRAE/ANSI 13256-1 Performance	56	ECM Control Features	81
Reference Calculations & Legend	57	Blower Performance Data	83
Full Load Correction Factors	58	Auxiliary Electric Heat	84
Part Load Correction Factors	59	Auxiliary Heat Ratings	84
Performance Data	60	Auxiliary Heat Electrical Data	84
Performance Data Selection Notes	70	Engineering Guide Specifications	85
Physical Data	71	Accessories, Options, and Warranty	86
Dimensions — Vertical Upflow	72	Revision History	88

What's New with ClimateMaster's Tranquility 27®?

EarthPure® Refrigerant

EarthPure® is a non-chlorine based (HFC-410A) refrigerant, that with R-407C and R-134A, is seen as the future of all refrigerants used worldwide.

HFC-410A characteristics compared to R-22 are:

- Binary and near azeotropic mixture of 50% R-32 and 50% R-125.
- Higher efficiencies (50-60% higher operating pressures)
- Zero ozone depletion potential and low global warming potential.
- Virtually no glide. Unlike other alternative refrigerants, the two components in HFC-410A have virtually the same leak rates. Therefore, refrigerant can be added if necessary without recovering the charge.

MERV 11 2" Pleated filter

All Tranquility 27® units include a factory installed 2" filter rack/duct collar with a 2" pleated high efficiency MERV 11 air filter. The MERV (minimum efficiency reporting value per ASHRAE Standard 52.2)

design features ultra low velocity (<300 fpm) for extended filter life, low pressure drop (0.13 – 0.18 in. wg.) and high particulate efficiency (size E1=41%, E2=69% and E3=87%). The pleated design and low velocity combine to allow the filter to store a large amount of dirt and result in a practical replacement life of up to 6 months.

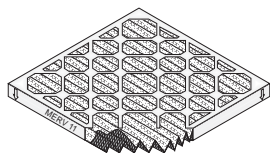

Tin Plated Air Coil

All ClimateMaster Tranquility 27® Series models feature an tin plated air-coil.

This plating process will provide years of protection against corrosion from airborne chemicals resulting from modern building material out gassing and most environmental chemicals found in the air. Modern building materials such as counter-tops, floor coverings, paints and other materials can "outgas" chemicals into the home's air. Some of these chemicals are suspected of contributing to corrosion in the air coils found in both traditional and geothermal heating and cooling equipment. Corrosion often results in refrigerant leaks and eventual failure of the air coil costing hundreds of dollars to replace. Studies have also shown that the air coil plating improves moisture shedding and therefore improve a unit's moisture removal capability resulting in a more comfortable home. The Tranquility 27® Series is your assurance of both maximum air coil life and comfort.

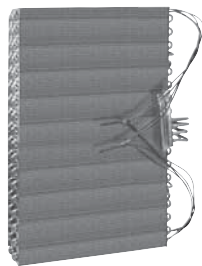

Copeland Scroll Compressor

Achieve a greater level of comfort. The Copeland Scroll UltraTech™ provides superior comfort than fixed-capacity compressors by incorporating a revolutionary two-step design. With a unique 67% part-load capacity step, systems with UltraTech™ maintain precise



temperature levels and lower relative humidity. This eliminates uneven peaks and valleys and allows for steady cooling comfort. Homeowners now have a better, more efficient way to power their heating and cooling system, raising their level of comfort, while lowering energy bills. So when your customers need a new heating and cooling system, make sure it has the best technology inside – the Copeland Scroll UltraTech™ compressor.

Save with superior efficiency. Over 40% of summer utility bills can come from the air conditioner compressor operation. A system with the Copeland Scroll UltraTech™ compressor delivers higher efficiency than any other single compressor system. In fact, systems with UltraTech™ provide up to 50% greater energy efficiency as compared to 13-SEER systems – which can save homeowners hundreds of dollars a year in energy costs.

Take it easy with quieter control. Copeland Scroll UltraTech™ is remarkably quiet at both full- and part-load capacity. In fact, it is up to four times quieter than a reciprocating compressor. Homeowners can enjoy its superior efficiency and comfort without having to hear the operation.

Learn the beauty of the design. With Copeland Scroll UltraTech™, two internal bypass ports enable the system to run at 67% part-load capacity for better

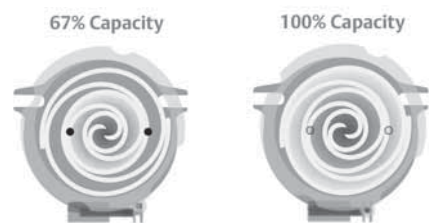

efficiency and humidity control. Based on demand, the modulation ring is activated, sealing the bypass ports and instantly shifting capacity to 100%. Take advantage of "shift on the fly" stage changing (no stopping and starting required like other two-stage compressors).

Choose proven scroll performance. While Copeland Scroll UltraTech™ builds on established scroll technology, it is still a scroll at heart, which means it operates with fewer moving parts, no volumetric efficiency drop-off or compression leakage. The result is unsurpassed reliability and virtually silent operation for both indoor and outdoor applications.

Other New Features

- Stylish two-tone look with textured black powder coat paint and stainless steel front access panels.
- Liftout handles for front access panels.
- Corrosion and stain resistant stainless steel drain pan with extra slope designed in.
- Factory mounted filter drier for trouble free reliability.
- Easy access low profile horizontal control box.
- Double isolated compressor for quiet and vibration free operation.
- Foil faced insulation in air handling compartment to allow easy cleaning and prevent microfiber introduction into the air stream.
- Open Service-Friendly Cabinet (i.e., all components in compressor section can be serviced from the front).

Tranquility 27[®] Design Features

The Tranquility 27[®] Series has abundant features and ultra high efficiency.

Application Flexibility

- Five Capacities 026, 038, 049, 064, and 072.
- Extended range operation (20-120°F EWT) and flow rates as low as 1.5 gpm per ton.
- Two-Stage upflow, downflow, and horizontal right or left return.
- Internally trapped condensate drain.
- Variable speed ECM fan motor adapts to various duct systems.
- Internal electric heat unit (optional) designed for easy field installation.
- Circuit breaker protected loop and hot water generator pumps.
- Field selectable low-temperature protection setting for GWHP or GLHP.
- Standard pre-installed 2" filter frame with 2" high performance MERV 11 pleated air filter.*

Operating Efficiencies

- EarthPure[®] HFC-410A zero ozone depletion refrigerant.
- Highest efficiencies in AHRI/ISO/ASHRAE/ANSI 13256-1 ratings for heating COP's, cooling EER's with low water flow rates.
- 27 EER/4.6 COP.
- Two-Stage operation for ultra high efficiencies and unsurpassed comfort.
- Optional hot water generator with internal pump generates hot water at considerable savings.
- Rugged and highly efficient next generation Copeland UltraTech™ scroll compressors provide ultra high efficiencies and full capacity with reduced cycling losses.
- Oversized coaxial tube water-to-refrigerant heat exchangers operate at low liquid pressure drop. Convulsed copper (and optional cupro-nickel) water tube functions efficiently at low-flow rates and provides low-temperature-damage resistance.
- Oversized tin plated, rifled tube/lanced aluminum fin, air to refrigerant heat exchangers provide high efficiency at low face velocity.
- Large low RPM blowers with variable speed fan motors provide quiet, efficient air movement with high static capability.
- Exceeds federal requirements for 30% tax credit on installation costs.
- Exceeds ASHRAE 90.1 and Energy Star 3.0 efficiencies.

Service & Installation Advantages

- Removable panels - 3 for compressor 2 for air handling compartment.
- Low profile control box grants easy access to all internal components.
- Factory installed liquid line filter/drier.
- Brass swivel-type water connections for quick connection and elimination of wrenches or sealants during installation.
- Bi-directional thermal expansion valve.
- CXM control features status lights with memory for easy diagnostics.
- Circuit breaker protected 75VA control transformer.

- ECM control board features thermostat signal diagnostic LEDs, airflow display LED (100 CFM per flash), and simplified CFM selection.
- Insulated divider and separate air handling/compressor compartments permit service testing without air bypass.
- Fan motors have quick attach wiring harness for fast removal.
- Internal dropout blower for easy servicing.
- High and low pressure service ports on refrigerant circuit.
- Accurate refrigerant sensing low-temperature protection.
- Solid state CXM digital compressor control features: Anti-short cycle, high & low pressure, loss of charge protection, LED fault, and status indication with memory for easy diagnostics.
- Intelligent fault retry -Condensate overflow protection.
- Air coil low temperature cut-out using high accuracy thermistor.
- 24vac accessory relays.
- Exclusive UPS (Unit Performance Sentinel) feature provides early warning of inefficient operating conditions before unit shutdown actually occurs reducing the need for emergency service work, thus letting you fix problems in the early stages. Fault types are not only indicated at the control, but are stored in memory after a user reset for future service use. Fault types can be displayed at the thermostat if equipped with fault LED or display.
- Electronic fan control module (units with ECM fan motor): Independent Heating and Cooling CFM selection, CFM display LED, Input status LEDs, and Dehumidification mode.

Factory Quality & Industry Certifications

- All units are built on our Integrated Process Control Assembly System (IPCS). The IPCS is a unique state-of-the-art manufacturing system that is designed to assure quality of the highest standards of any manufacturer in the water-source industry. Our IPCS system:
 - Verifies that the correct components are being assembled.
 - Automatically performs special leak tests on all joints.
 - Conducts pressure tests.
 - Performs highly detailed run test unparalleled in the HVAC industry.
 - Automatically disables packaging for a "failed" unit.
- All units are water run-tested in all modes to insure efficiency and reliability.
- Heavy gauge galvanized steel cabinets are epoxy powder coated for durable and long-lasting finish.
- All refrigerant brazing is done in a nitrogen atmosphere.
- All units are deep evacuated to less than 100 microns prior to refrigerant charging.
- All joints are both helium and halogen leak tested to insure annual leak rate of less than 1/4 ounce.
- Coaxial heat exchanger, refrigerant suction lines and all water lines are fully insulated to eliminate condensation problems in low temperature applications.
- Noise reduction features include: dual level compressor isolation; insulated compressor compartment; interior cabinet insulation using 1/2" coated glass fiber and variable speed fan.
- Safety features include: high pressure and loss of charge to protect the compressor, condensate overflow protection, low-temperature protection sensors to safeguard the coaxial heat exchanger and air coil, hot water high-limit, and low compressor discharge temperature switch provided to shut down the hot

Tranquility 27® Design Features

water generator when conditions dictate. Fault lockout enables emergency heat and prevents compressor operation until thermostat or circuit breaker has been reset.

- Standard 10-year limited warranty on all parts with 5-year labor allowance; Optional additional extended 5-year limited labor allowance available.
- AHRI/ASHRAE/ANSI/ISO 13256-1 certified.
- ETL listed.
- US EPA "Energy Star" compliant.
- ISO 9001:2000 Certified.

Simplified Controls

- CXM solid state control module.
- 'CFM' LED displays airflow.
- Dehumidification mode for higher latent cooling.

Options & Accessories

- Hot water generator with internally mounted pump.
- Cupro-nickel coaxial heat exchanger.
- Electronic thermostat.
- Closed loop flow controller.
- Electronic auto-changeover thermostat with 3-stage heat, 2-stage cool and indicator LEDs.
- Hose kits.
- ClimaDry® Whole House Dehumidification.
- Additional extended 5-year limited labor allowance.
- Internal electric heat for easy field installation.

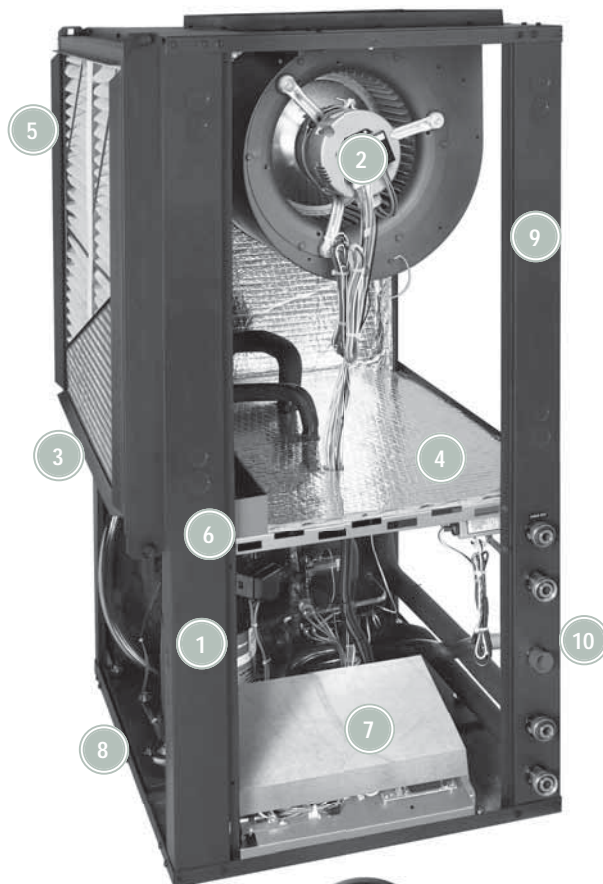

Features EarthPure®
HFC-410A Zero Ozone
Depletion Refrigerant

- 1 Copeland™ Ultra-Tech™ Two-Stage Unloading Scroll Compressor
- 2 Variable speed ECM fan motor adapts to various duct systems
- 3 Tin Plated Air Coil- Long Life, Easy Cleaning and Better Condensate Runoff
- 4 Foil Faced Insulation in the Blower Section, Fully Insulated Compressor Section
- 5 Two Inch Filter Frame With High Performance MERV 11 Pleated Air Filter*
- 6 Stainless Steel Drain Pan for Long Life
- 7 Unit Performance Sentinel: Automatic Alert System Lets You Know If The System Is Not Running At Peak Performance**
- 8 Dual Level Compressor Isolation for Ultra Quiet Operation
- 9 Five Easy, Lift-out Service Access Panels With Stainless Steel Front Panels
- 10 Internally Trapped Condensate Piping

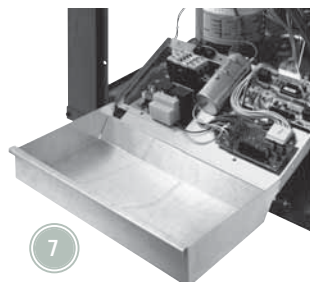
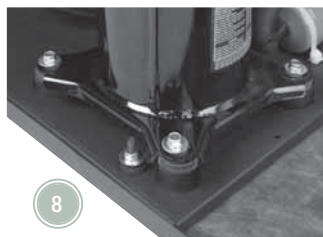

* MERV= Minimum Efficiency Reporting Value as specified by ASHRAE (American Society of Heating, Refrigerating and Air Conditioning Engineers) standard 52.2.

** When installed with a ClimateMaster Residential Thermostat.

Unit Model Key

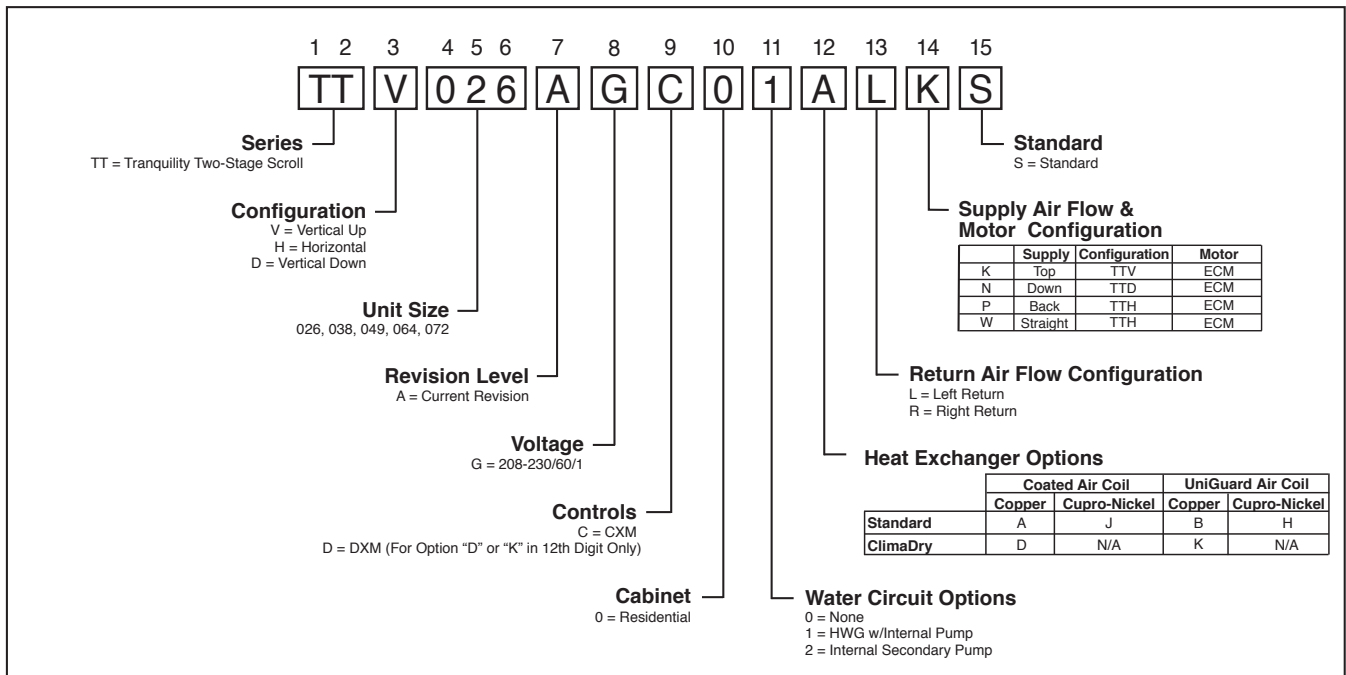

Rev.: 9 July, 2010B

About AHRI/ISO/ASHRAE 13256-1

About AHRI/ISO/ASHRAE 13256-1

AHRI/ASHRAE/ISO 13256-1 (Air-Conditioning and Refrigeration Institute/American Society of Heating, Refrigerating and Air Conditioning Engineers/International Standards Organization) is a certification standard for water-source heat pumps used in the following applications:

- WLHP (Water Loop Heat Pump – Boiler/Tower)
- GWHP (Ground Water Heat Pump – Open Loop)
- GLHP (Ground Loop Heat Pump – Geothermal)

The directory at <http://www.ahrinet.org/> is constantly being updated and immediately available on the Internet. All ratings are submitted by the manufacturer for certification, and must be approved by AHRI. Therefore, there is a significant difference between AHRI “certified” and AHRI “rated.” Thirty percent of a manufacturer’s basic models must be tested each year. AHRI selects models at random from stock for testing on the basis of its evaluation of a participant’s certification data.

Units that fail one or more certified test (90% of declared performance or lower) may be declared defective. If the initial failure is a performance test, the manufacturer must obsolete all units within the same basic model group or elect to have a second sample tested. If the second unit fails a performance test, it must be obsoleted, together with all units within the same basic model group. ClimateMaster takes certification seriously. We were recently awarded a certificate for consecutive years of no AHRI failures.

Temperatures used in AHRI certification standards are S.I. (Système International – metric) based. For example, typical catalog data for cooling is shown at 80°F DB/67°F WB [26.7°C DB/19.4°C] entering air temperature, but the AHRI standard for cooling is 80.6°F DB/66.2°F WB [27°C DB/19°C], since it is based upon whole numbers in degrees Celsius. Water and air temperatures for the standard are shown below.

Test Condition Comparison Table

	WLHP	GWHP	GLHP
Cooling			
Entering Air Temperature - DB/WB °F [°C]	80.6/66.2 [27/19]	80.6/66.2 [27/19]	80.6/66.2 [27/19]
Entering Water Temperature - °F [°C]	86 [30]	59 [15]	77 [25]
Fluid Flow Rate	*	*	*
Heating			
Entering Air Temperature - DB/WB °F [°C]	68 [20]	68 [20]	68 [20]
Entering Water Temperature - °F [°C]	68 [20]	50 [10]	32 [0]
Fluid Flow Rate	*	*	*

*Flow rate is specified by the manufacturer

Data certified by AHRI include heating/cooling capacities, EER (Energy Efficiency Ratio – Btuh per Watt) and COP (Btuh per Btuh) at the various conditions shown above. Pump power correction is calculated to adjust efficiencies for pumping Watts. Within each model, only one water flow rate is specified for all three groups, and pumping Watts are calculated using the formula below. This additional power is added onto the existing power consumption.

- Pump power correction = (gpm x 0.0631) x (Press Drop x 2990)/300

Fan power is corrected to zero external static pressure using the equation below. The nominal airflow is rated at a specific external static pressure. This effectively reduces the power consumption of the unit and increases cooling capacity but decreases heating capacity.

- Fan Power Correction = (cfm x 0.472) x (esp x 249)/300

Capacities and efficiencies are calculated using the following equations:

- ISO Cooling Capacity = Cooling Capacity (Btuh) + [Fan Power Correction (Watts) x 3.412]
- ISO EER Efficiency (Btuh/W) =
ISO Cooling Capacity (Btuh)/[Power Input (Watts) – Fan Power Correction (Watts) + Pump Power Correction (Watts)]
- ISO Heating Capacity = Heating Capacity (Btuh) – [Fan Power Correction (Watts) x 3.412]
- ISO COP Efficiency (Btuh/Btuh) =
ISO Heating Capacity (Btuh) x 3.412/[Power Input (Watts) - Fan Power Correction (Watts) + Pump Power Correction (Watts)]

AHRI/ISO/ASHRAE/ANSI 13256-1 Performance

ASHRAE/AHRI/ISO 13256-1. English (IP) Units

Model	Capacity Modulation	Water Loop Heat Pump				Ground Water Heat Pump				Ground Loop Heat Pump			
		Cooling 86°F		Heating 68°F		Cooling 59°F		Heating 50°F		Cooling Full Load 77°F Part Load 68°F		Heating Full Load 32°F Part Load 41°F	
		Capacity Btuh	EER Btuh/W	Capacity Btuh	COP	Capacity Btuh	EER Btuh/W	Capacity Btuh	COP	Capacity Btuh	EER Btuh/W	Capacity Btuh	COP
TT026	Full	25,300	15.9	30,800	5.3	28,900	24.5	25,700	4.8	26,600	18.5	19,800	4.0
	Part	19,400	18.3	22,400	6.1	22,200	30.8	18,600	5.1	21,300	26.0	16,500	4.6
TT038	Full	36,200	15.6	44,800	5.3	41,200	23.0	36,700	4.7	38,200	18.2	29,000	4.0
	Part	26,200	18.5	30,800	6.3	30,200	31.5	24,800	5.1	28,900	27.0	22,100	4.5
TT049	Full	48,400	15.7	59,900	5.2	54,600	22.5	48,300	4.7	50,600	17.9	37,500	4.0
	Part	36,100	18.0	44,300	6.2	40,700	28.7	35,400	5.1	39,600	24.9	31,200	4.6
TT064	Full	61,500	15.0	72,300	5.0	68,600	22.0	59,600	4.4	64,800	17.5	48,000	3.9
	Part	44,900	17.6	51,100	5.7	51,900	29.7	41,800	4.7	49,800	25.3	37,500	4.3
TT072	Full	68,700	14.2	88,600	4.9	77,100	19.9	70,200	4.3	71,600	16.2	54,100	3.6
	Part	52,800	16.0	65,200	5.1	59,800	24.5	51,700	4.3	57,700	21.4	45,400	3.9

Cooling capacities based upon 80.6°F DB, 66.2°F WB entering air temperature
 Heating capacities based upon 68°F DB, 59°F WB entering air temperature
 Ground Loop Heat Pump ratings based on 15% methanol antifreeze solution
 All ratings based upon operation at lower voltage of dual voltage rated models

ASHRAE/AHRI/ISO 13256-1. Metric (SI) Units

Model	Capacity Modulation	Water Loop Heat Pump				Ground Water Heat Pump				Ground Loop Heat Pump			
		Cooling 30°C		Heating 20°C		Cooling 15°C		Heating 10°C		Cooling Full Load 25°C Part Load 20°C		Heating Full Load 0°C Part Load 5°C	
		Capacity Watts	EER W/W	Capacity Watts	COP	Capacity Watts	EER W/W	Capacity Watts	COP	Capacity Watts	EER W/W	Capacity Watts	COP
TT026	Full	7,415	4.7	9,027	5.3	8,470	7.2	7,532	4.8	7,796	5.4	5,803	4.0
	Part	5,686	5.4	6,565	6.1	6,506	9.0	5,451	5.1	6,243	7.6	4,836	4.6
TT038	Full	10,610	4.6	13,130	5.3	12,075	6.7	10,756	4.7	11,196	5.3	8,499	4.0
	Part	7,679	5.4	9,027	6.3	8,851	9.2	7,268	5.1	8,470	7.9	6,477	4.5
TT049	Full	14,185	4.6	17,556	5.2	16,002	6.6	14,156	4.7	14,830	5.2	10,991	4.0
	Part	10,580	5.3	12,984	6.2	11,928	8.4	10,375	5.1	11,606	7.3	9,144	4.6
TT064	Full	18,025	4.4	21,190	5.0	20,106	6.4	17,468	4.4	18,992	5.1	14,068	3.9
	Part	13,159	5.2	14,977	5.7	15,211	8.7	12,251	4.7	14,596	7.4	10,991	4.3
TT072	Full	20,135	4.2	25,967	4.9	22,597	5.8	20,574	4.3	20,985	4.7	15,856	3.6
	Part	15,475	4.7	19,109	5.1	17,526	7.2	15,152	4.3	16,911	6.3	13,306	3.9

Cooling capacities based upon 27°C DB, 19°C WB entering air temperature
 Heating capacities based upon 20°C DB, 15°C WB entering air temperature
 Ground Loop Heat Pump ratings based on 15% methanol antifreeze solution
 All ratings based upon operation at lower voltage of dual voltage rated models

Reference Calculations & Legend

Heating		Cooling	
$LWT = EWT - \frac{HE}{GPM \times 500}$	$LWT = EWT + \frac{HR}{GPM \times 500}$	$LC = TC - SC$	
$LAT = EAT + \frac{HC}{CFM \times 1.08}$	$LAT (DB) = EAT (DB) - \frac{SC}{CFM \times 1.08}$	$S/T = \frac{SC}{TC}$	

Hot Water Generator capacities (HWC) are based on potable water flow rate of 0.4 gpm per nominal equipment ton and 90°F entering potable water temperature.

CFM = airflow, cubic feet/minute	HE = total heat of extraction, Mbtuh
EWT = entering water temperature, °F	HWC = Hot Water Generator (desuperheater) capacity, Mbtuh
GPM = water flow in US gallons/minute	WPD = Water coil pressure drop (psi & ft hd)
EAT = entering air temperature, Fahrenheit (dry bulb/wet bulb)	EER = Energy Efficiency Ratio = BTU output/Watt input
HC = air heating capacity, Mbtuh	COP = Coefficient of Performance = BTU output/BTU input
TC = total cooling capacity, Mbtuh	LWT = leaving water temperature, °F
SC = sensible cooling capacity, Mbtuh	LAT = leaving air temperature, °F
KW = total power unit input, KiloWatts	LC = latent cooling capacity, Mbtuh
HR = total heat of rejection, Mbtuh	S/T = sensible to total cooling ratio

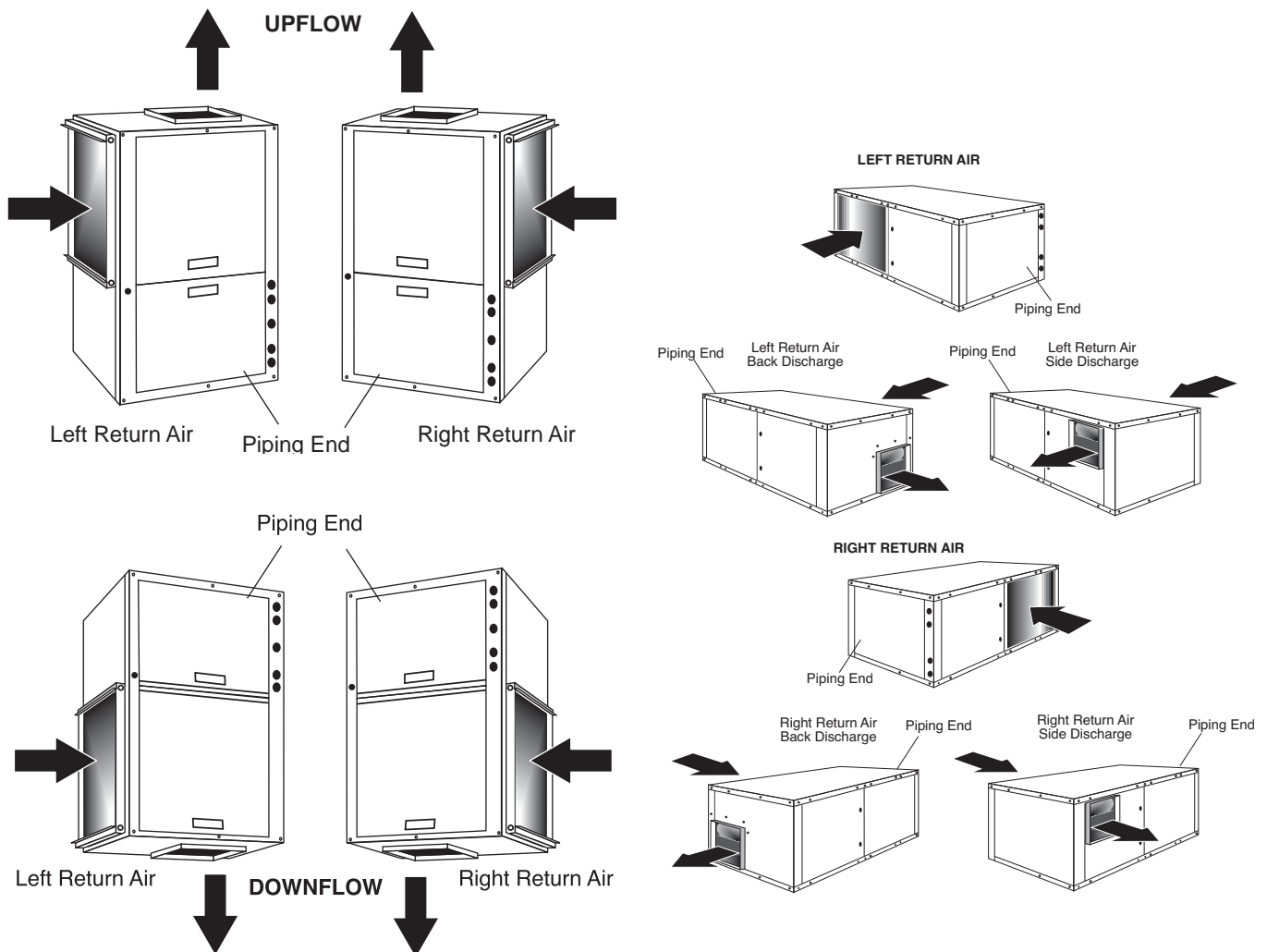

Full Load Correction Factors

Air Flow Correction Table

Airflow	Cooling				Heating		
	% of Rated	Total Capacity	Sensible Capacity	Power	Heat of Rejection	Heating Capacity	Power
60%	0.925	0.788	0.913	0.922	0.946	1.153	0.896
69%	0.946	0.829	0.926	0.942	0.959	1.107	0.924
75%	0.960	0.861	0.937	0.955	0.969	1.078	0.942
81%	0.972	0.895	0.950	0.968	0.977	1.053	0.959
88%	0.983	0.930	0.965	0.979	0.985	1.032	0.974
94%	0.992	0.965	0.982	0.990	0.993	1.014	0.988
100%	1.000	1.000	1.000	1.000	1.000	1.000	1.000
106%	1.007	1.033	1.020	1.009	1.006	0.989	1.011
113%	1.012	1.064	1.042	1.018	1.012	0.982	1.019
119%	1.016	1.092	1.066	1.025	1.018	0.979	1.027
125%	1.018	1.116	1.091	1.032	1.022	0.977	1.033
130%	1.019	1.132	1.112	1.037	1.026	0.975	1.038

Entering Air Correction Table

Heating			
Entering Air DB°F	Heating Capacity	Power	Heat of Extraction
40	1.052	0.779	1.120
45	1.043	0.808	1.102
50	1.035	0.841	1.084
55	1.027	0.877	1.065
60	1.019	0.915	1.045
65	1.010	0.957	1.023
68	1.004	0.982	1.010
70	1.000	1.000	1.000
75	0.989	1.045	0.974
80	0.976	1.093	0.946

* = Sensible capacity equals total capacity
 AHRI/ISO/ASHRAE 13256-1 uses entering air conditions of Cooling - 80.6°F DB/66.2°F WB,
 and Heating - 68°F DB/59°F WB entering air temperature

Cooling													
Entering Air WB°F	Total Capacity	Sensible Cooling Capacity Multiplier - Entering DB °F										Power	Heat of Rejection
		60	65	70	75	80	80.6	85	90	95	100		
45	0.832	1.346	1.461	1.603	*	*	*	*	*	*	*	0.946	0.853
50	0.850	1.004	1.174	1.357	*	*	*	*	*	*	*	0.953	0.870
55	0.880	0.694	0.902	1.115	1.331	*	*	*	*	*	*	0.964	0.896
60	0.922		0.646	0.875	1.103	1.329	1.356	*	*	*	*	0.977	0.932
65	0.975			0.639	0.869	1.096	1.123	1.320	*	*	*	0.993	0.979
66.2	0.990			0.582	0.812	1.039	1.066	1.262	1.482	*	*	0.997	0.991
67	1.000			0.545	0.774	1.000	1.027	1.223	1.444	*	*	1.000	1.000
70	1.040				0.630	0.853	0.880	1.075	1.297	1.517	*	1.011	1.035
75	1.117					0.601	0.627	0.821	1.046	1.275	1.510	1.033	1.101

Part Load Correction Factors

Air Flow Correction Table

Airflow	Cooling				Heating		
	% of Rated	Total Capacity	Sensible Capacity	Power	Heat of Rejection	Heating Capacity	Power
60%	0.920	0.781	0.959	0.927	0.946	1.241	0.881
69%	0.942	0.832	0.964	0.946	0.960	1.163	0.915
75%	0.956	0.867	0.696	0.959	0.969	1.115	0.937
81%	0.969	0.901	0.975	0.970	0.978	1.076	0.956
88%	0.981	0.934	0.982	0.981	0.986	1.043	0.973
94%	0.991	0.967	0.990	0.991	0.993	1.018	0.988
100%	1.000	1.000	1.000	1.000	1.000	1.000	1.000
106%	1.007	1.033	1.011	1.008	1.006	0.990	1.010
113%	1.013	1.065	1.023	1.015	1.012	0.986	1.017
119%	1.018	1.098	1.036	1.021	1.017	0.983	1.024
125%	1.021	1.131	1.051	1.026	1.021	0.981	1.030
130%	1.023	1.159	1.063	1.030	1.024	0.979	1.034

Entering Air Correction Table

Heating			
Entering Air DB°F	Heating Capacity	Power	Heat of Extraction
40	1.084	0.732	1.161
45	1.073	0.764	1.140
50	1.060	0.802	1.117
55	1.046	0.846	1.090
60	1.031	0.893	1.061
65	1.016	0.945	1.031
68	1.006	0.978	1.013
70	1.000	1.000	1.000
75	0.984	1.058	0.968
80	0.968	1.117	0.936

* = Sensible capacity equals total capacity
 AHRI/ISO/ASHRAE 13256-1 uses entering air conditions of Cooling - 80.6°F DB/66.2°F WB,
 and Heating - 68°F DB/59°F WB entering air temperature

Cooling													
Entering Air WB°F	Total Capacity	Sensible Cooling Capacity Multiplier - Entering DB °F										Power	Heat of Rejection
		60	65	70	75	80	80.6	85	90	95	100		
45	0.876	1.286	1.302	1.389	*	*	*	*	*	*	*	0.981	0.895
50	0.883	1.002	1.099	1.241	*	*	*	*	*	*	*	0.985	0.901
55	0.903	0.706	0.871	1.060	1.271	*	*	*	*	*	*	0.989	0.918
60	0.935		0.617	0.844	1.079	1.319	1.349	*	*	*	*	0.993	0.945
65	0.979			0.595	0.849	1.096	1.128	1.342	*	*	*	0.998	0.982
66.2	0.991			0.531	0.789	1.040	1.070	1.284	1.522	*	*	0.999	0.993
67	1.000			0.486	0.747	1.000	1.030	1.245	1.481	*	*	1.000	1.000
70	1.035				0.583	0.842	0.873	1.090	1.327	1.552	*	1.003	1.030
75	1.105					0.552	0.584	0.811	1.057	1.290	1.510	1.008	1.088

Tranquility 27® (TT) Series

Performance Data — Tranquility 27® Model 026 - Part Load

725 CFM Nominal (Rated) Airflow Cooling, 825 CFM Nominal (Rated) Airflow Heating

Performance capacities shown in thousands of Btu/h

EWT °F	GPM	WPD		Cooling - EAT 80/67°F							Heating - EAT 70°F						
		PSI	FT	Airflow CFM	TC	SC	kW	HR	EER	HW	Airflow CFM	HC	kW	HE	LAT	COP	HW
20	7.0	4.5	10.3	Operation not recommended													
	7.0	4.5	10.3	Operation not recommended													
30	3.5	1.2	2.8	620	22.2	14.0	0.58	24.1	38.3	0.5	710	13.6	1.09	10.1	87.8	3.66	1.6
	3.5	1.2	2.8	725	22.5	14.7	0.59	24.4	38.3	0.5	825	13.8	1.06	10.3	85.5	3.81	1.6
	5.8	2.9	6.6	620	22.4	14.0	0.57	24.3	39.2	0.4	710	14.2	1.09	10.7	88.5	3.81	1.6
	5.8	2.9	6.6	725	22.7	14.7	0.58	24.7	39.2	0.5	825	14.4	1.06	10.9	86.1	3.97	1.7
	7.0	4.1	9.4	620	22.5	14.0	0.56	24.4	39.8	0.4	710	14.4	1.09	10.9	88.8	3.86	1.7
	7.0	4.1	9.4	725	22.8	14.7	0.57	24.7	39.8	0.4	825	14.6	1.06	11.1	86.3	4.02	1.7
40	3.5	1.1	2.5	620	22.9	15.1	0.65	25.1	35.3	0.7	710	16.1	1.15	12.3	90.9	4.08	1.7
	3.5	1.1	2.5	725	23.3	15.8	0.66	25.5	35.3	0.7	825	16.2	1.12	12.6	88.2	4.25	1.7
	5.8	2.6	5.9	620	23.1	15.1	0.61	25.2	37.9	0.7	710	16.7	1.15	13.0	91.8	4.25	1.8
	5.8	2.6	5.9	725	23.4	15.9	0.62	25.5	37.9	0.7	825	16.9	1.12	13.3	89.0	4.42	1.8
	7.0	3.6	8.4	620	23.2	15.1	0.60	25.2	38.3	0.6	710	16.9	1.16	13.2	92.1	4.30	1.8
	7.0	3.6	8.4	725	23.5	15.9	0.61	25.6	38.3	0.6	825	17.1	1.12	13.5	89.2	4.47	1.8
50	3.5	1.0	2.3	620	22.7	15.4	0.74	25.2	30.7	1.1	710	18.3	1.18	14.5	93.9	4.56	1.8
	3.5	1.0	2.3	725	23.0	16.2	0.75	25.6	30.7	1.1	825	18.5	1.14	14.8	90.8	4.75	1.8
	5.8	2.4	5.6	620	22.9	15.5	0.69	25.3	33.4	1.0	710	19.1	1.18	15.2	94.8	4.73	1.9
	5.8	2.4	5.6	725	23.3	16.3	0.70	25.6	33.4	1.0	825	19.3	1.15	15.5	91.6	4.93	1.9
	7.0	3.4	7.9	620	23.0	15.5	0.67	25.3	34.1	0.9	710	19.3	1.18	15.4	95.1	4.78	1.9
	7.0	3.4	7.9	725	23.3	16.3	0.68	25.6	34.1	0.9	825	19.5	1.15	15.7	91.9	4.98	2.0
60	3.5	1.0	2.2	620	21.9	15.3	0.85	24.8	25.9	2.2	710	20.4	1.21	16.5	96.6	4.93	2.0
	3.5	1.0	2.2	725	22.2	16.1	0.86	25.1	25.9	2.2	825	20.6	1.18	16.8	93.2	5.13	2.0
	5.8	2.3	5.2	620	22.4	15.5	0.78	25.1	28.6	2.0	710	21.2	1.22	17.3	97.7	5.10	2.1
	5.8	2.3	5.2	725	22.7	16.3	0.80	25.4	28.6	2.0	825	21.5	1.18	17.6	94.1	5.31	2.1
	7.0	3.2	7.4	620	22.5	15.5	0.77	25.1	29.4	1.7	710	21.5	1.22	17.5	98.0	5.15	2.1
	7.0	3.2	7.4	725	22.9	16.3	0.78	25.5	29.4	1.8	825	21.7	1.19	17.8	94.3	5.36	2.2
70	3.5	0.9	2.1	620	20.7	14.8	0.97	24.0	21.4	1.9	710	22.4	1.23	18.4	99.2	5.35	2.2
	3.5	0.9	2.1	725	21.0	15.6	0.98	24.3	21.4	2.0	825	22.7	1.19	18.8	95.4	5.57	2.2
	5.8	2.1	4.9	620	21.4	15.1	0.90	24.4	23.8	1.8	710	23.3	1.24	19.3	100.4	5.52	2.2
	5.8	2.1	4.9	725	21.7	15.9	0.91	24.8	23.8	1.8	825	23.5	1.20	19.6	96.4	5.75	2.3
	7.0	3.0	7.0	620	21.6	15.2	0.88	24.6	24.5	1.6	710	23.5	1.24	19.5	100.7	5.57	2.3
	7.0	3.0	7.0	725	21.9	16.0	0.89	24.9	24.5	1.6	825	23.8	1.20	19.9	96.7	5.80	2.4
80	3.5	0.8	1.9	620	19.3	14.2	1.10	23.1	17.5	2.5	710	24.4	1.25	20.3	101.8	5.73	2.3
	3.5	0.8	1.9	725	19.6	14.9	1.12	23.4	17.5	2.5	825	24.6	1.21	20.7	97.7	5.97	2.3
	5.8	2.0	4.6	620	20.1	14.5	1.03	23.6	19.5	2.3	710	25.3	1.26	21.2	103.0	5.90	2.4
	5.8	2.0	4.6	725	20.4	15.3	1.04	23.9	19.5	2.3	825	25.6	1.22	21.6	98.7	6.15	2.4
	7.0	2.8	6.5	620	20.3	14.6	1.01	23.7	20.1	2.1	710	25.6	1.26	21.5	103.4	5.95	2.5
	7.0	2.8	6.5	725	20.6	15.4	1.02	24.0	20.1	2.2	825	25.9	1.22	21.9	99.0	6.20	2.5
85	3.5	0.8	1.9	620	18.7	13.9	1.18	22.7	15.9	2.9	710	25.3	1.26	21.2	103.0	5.91	2.4
	3.5	0.8	1.9	725	18.9	14.6	1.19	23.0	15.9	3.0	825	25.6	1.22	21.7	98.7	6.15	2.4
	5.8	1.9	4.5	620	19.3	14.2	1.10	23.1	17.5	2.7	710	26.3	1.27	22.2	104.3	6.08	2.5
	5.8	1.9	4.5	725	19.6	14.9	1.12	23.4	17.5	2.8	825	26.6	1.23	22.6	99.9	6.33	2.5
	7.0	2.7	6.3	620	19.5	14.3	1.08	23.2	18.0	2.5	710	26.6	1.27	22.5	104.7	6.13	2.6
	7.0	2.7	6.3	725	19.8	15.0	1.10	23.6	18.0	2.6	825	26.9	1.24	22.9	100.2	6.38	2.6
90	3.5	0.8	1.8	620	18.0	13.7	1.25	22.3	14.4	3.3	710	26.3	1.27	22.2	104.3	6.08	2.5
	3.5	0.8	1.8	725	18.3	14.4	1.27	22.6	14.4	3.4	825	26.6	1.23	22.6	99.8	6.33	2.5
	5.8	1.9	4.4	620	18.6	13.8	1.18	22.6	15.8	3.1	710	27.3	1.28	23.1	105.6	6.25	2.5
	5.8	1.9	4.4	725	18.9	14.6	1.20	22.9	15.8	3.1	825	27.6	1.24	23.6	101.0	6.51	2.6
	7.0	2.7	6.2	620	18.8	13.9	1.16	22.7	16.3	2.8	710	27.6	1.28	23.4	106.0	6.30	2.6
	7.0	2.7	6.2	725	19.1	14.7	1.17	23.1	16.3	2.9	825	27.9	1.25	23.9	101.3	6.56	2.7
100	3.5	0.8	1.8	620	16.6	13.0	1.41	21.4	11.7	3.9	Operation not recommended						
	3.5	0.8	1.8	725	16.8	13.7	1.43	21.7	11.7	4.0							
	5.8	1.8	4.2	620	17.1	13.2	1.34	21.7	12.7	3.7							
	5.8	1.8	4.2	725	17.4	13.8	1.36	22.0	12.7	3.8							
	7.0	2.6	6.0	620	17.3	13.3	1.32	21.8	13.1	3.6							
	7.0	2.6	6.0	725	17.5	13.9	1.34	22.1	13.1	3.7							
110	3.5	0.7	1.7	620	15.5	12.7	1.59	20.9	9.7	5.0	Operation not recommended						
	3.5	0.7	1.7	725	15.7	13.4	1.61	21.2	9.7	5.1							
	5.8	1.7	4.0	620	15.8	12.7	1.53	21.0	10.3	4.8							
	5.8	1.7	4.0	725	16.0	13.3	1.55	21.3	10.3	4.9							
	7.0	2.5	5.7	620	16.0	12.7	1.50	21.1	10.6	4.6							
	7.0	2.5	5.7	725	16.2	13.4	1.52	21.4	10.6	4.7							
120	3.5	0.7	1.6	620	14.5	12.6	1.84	20.8	7.9	6.3	Operation not recommended						
	3.5	0.7	1.6	725	14.7	13.3	1.86	21.1	7.9	6.4							
	5.8	1.7	3.9	620	14.8	12.5	1.73	20.7	8.6	6.0							
	5.8	1.7	3.9	725	15.0	13.2	1.76	21.0	8.6	6.2							
	7.0	2.4	5.5	620	14.9	12.5	1.71	20.7	8.7	5.8							
	7.0	2.4	5.5	725	15.1	13.2	1.73	21.0	8.7	5.9							

Interpolation is permissible; extrapolation is not.
 All entering air conditions are 80°F DB and 67°F WB in cooling, and 70°F DB in heating.
 AHRI/ISO certified conditions are 80.6°F DB and 66.2°F WB in cooling and 68°F DB in heating.
 Table does not reflect fan or pump power corrections for AHRI/ISO conditions.
 All performance is based upon the lower voltage of dual voltage rated units.
 Operation below 40°F EWT is based upon a 15% methanol antifreeze solution.
 Operation below 60°F EWT requires optional insulated water/refrigerant circuit.
 See performance correction tables for operating conditions other than those listed above.
 For operation in the shaded areas, please see the Performance Data Selection Notes.

Performance Data — Tranquility27® Model 026 - Full Load

850 CFM Nominal (Rated) Airflow Cooling, 950 CFM Nominal (Rated) Airflow Heating

Performance capacities shown in thousands of Btu/h

EWT °F	GPM	WPD		Cooling - EAT 80/67°F							Heating - EAT 70°F						
		PSI	FT	Airflow CFM	TC	SC	kW	HR	EER	HW	Airflow CFM	HC	kW	HE	LAT	COP	HW
20	8.0	5.6	12.9	Operation not recommended							820	15.0	1.47	10.2	86.9	3.00	1.7
	8.0	5.6	12.9	Operation not recommended							950	15.3	1.41	10.6	84.9	3.19	1.7
30	4.0	1.5	3.5	730	30.2	17.9	0.97	33.4	31.0	0.6	820	17.8	1.53	12.7	90.1	3.41	2.0
	4.0	1.5	3.5	850	30.9	19.6	1.02	34.3	30.4	0.6	950	18.1	1.46	13.2	87.7	3.63	2.0
	6.0	3.1	7.2	730	30.3	17.9	0.93	33.4	32.7	0.5	820	18.6	1.54	13.5	91.0	3.53	2.1
	6.0	3.1	7.2	850	31.1	19.6	0.97	34.4	32.1	0.6	950	19.0	1.48	14.0	88.5	3.76	2.1
	8.0	5.1	11.7	730	30.5	17.9	0.91	33.5	33.7	0.5	820	19.1	1.55	13.9	91.5	3.59	2.1
	8.0	5.1	11.7	850	31.2	19.6	0.95	34.5	33.1	0.5	950	19.4	1.49	14.4	88.9	3.82	2.2
40	4.0	1.4	3.1	730	29.9	18.2	1.07	33.5	28.1	1.0	820	21.2	1.61	15.9	94.0	3.88	2.3
	4.0	1.4	3.1	850	30.6	20.0	1.11	34.4	27.5	1.0	950	21.6	1.54	16.4	91.1	4.12	2.3
	6.0	2.8	6.5	730	30.2	18.3	1.01	33.6	29.8	0.9	820	22.2	1.63	16.7	95.0	3.99	2.4
	6.0	2.8	6.5	850	30.9	20.0	1.06	34.5	29.2	0.9	950	22.6	1.56	17.3	92.0	4.24	2.4
	8.0	4.6	10.5	730	30.3	18.3	0.99	33.6	30.7	0.8	820	22.7	1.64	17.2	95.6	4.05	2.5
	8.0	4.6	10.5	850	31.0	20.0	1.03	34.5	30.1	0.9	950	23.1	1.57	17.8	92.5	4.31	2.5
50	4.0	1.3	2.9	730	29.1	18.3	1.17	33.1	24.8	1.6	820	24.4	1.69	18.7	97.5	4.24	2.6
	4.0	1.3	2.9	850	29.8	20.0	1.23	34.0	24.3	1.6	950	24.9	1.62	19.4	94.2	4.51	2.7
	6.0	2.6	6.1	730	29.6	18.4	1.11	33.4	26.7	1.4	820	25.4	1.71	19.6	98.7	4.34	2.7
	6.0	2.6	6.1	850	30.3	20.1	1.16	34.3	26.1	1.5	950	25.9	1.64	20.3	95.2	4.62	2.8
	8.0	4.3	9.9	730	29.9	18.4	1.08	33.5	27.6	1.3	820	25.9	1.73	20.1	99.3	4.40	2.8
	8.0	4.3	9.9	850	30.6	20.2	1.13	34.4	27.0	1.3	950	26.4	1.66	20.8	95.7	4.68	2.9
60	4.0	1.2	2.8	730	28.0	17.9	1.30	32.4	21.6	2.2	820	27.2	1.77	21.3	100.8	4.52	2.9
	4.0	1.2	2.8	850	28.6	19.6	1.35	33.3	21.2	2.2	950	27.8	1.69	22.0	97.1	4.81	3.0
	6.0	2.5	5.7	730	28.7	18.1	1.23	32.8	23.4	2.0	820	28.3	1.8	22.2	101.9	4.62	3.1
	6.0	2.5	5.7	850	29.3	19.9	1.28	33.7	22.9	2.0	950	28.8	1.72	23.0	98.1	4.91	3.1
	8.0	4.0	9.3	730	29.0	18.2	1.19	33.0	24.3	1.7	820	28.8	1.81	22.7	102.6	4.66	3.2
	8.0	4.0	9.3	850	29.7	20.0	1.24	33.9	23.8	1.8	950	29.4	1.74	23.5	98.6	4.96	3.2
70	4.0	1.1	2.6	730	26.6	17.3	1.43	31.4	18.5	2.9	820	29.9	1.84	23.6	103.7	4.75	3.3
	4.0	1.1	2.6	850	27.2	19.0	1.50	32.3	18.2	3.0	950	30.5	1.77	24.4	99.7	5.05	3.3
	6.0	2.3	5.4	730	27.4	17.7	1.36	31.9	20.2	2.6	820	31.0	1.88	24.6	105.0	4.83	3.4
	6.0	2.3	5.4	850	28.0	19.4	1.42	32.8	19.8	2.7	950	31.6	1.80	25.4	100.8	5.14	3.5
	8.0	3.8	8.7	730	27.7	17.8	1.32	32.2	21.0	2.3	820	31.5	1.90	25.1	105.6	4.87	3.5
	8.0	3.8	8.7	850	28.4	19.5	1.38	33.1	20.6	2.4	950	32.1	1.82	25.9	101.3	5.18	3.6
80	4.0	1.0	2.4	730	25.0	16.6	1.59	30.4	15.7	3.5	820	32.3	1.92	25.8	106.5	4.93	3.6
	4.0	1.0	2.4	850	25.6	18.3	1.66	31.2	15.4	3.6	950	33.0	1.84	26.7	102.1	5.24	3.6
	6.0	2.2	5.0	730	25.8	17.0	1.50	30.9	17.2	3.2	820	33.5	1.96	26.8	107.8	5.01	3.7
	6.0	2.2	5.0	850	26.4	18.7	1.57	31.8	16.8	3.3	950	34.1	1.88	27.7	103.2	5.32	3.8
	8.0	3.5	8.1	730	26.3	17.2	1.46	31.2	17.9	3.0	820	34.0	1.98	27.3	108.4	5.04	3.9
	8.0	3.5	8.1	850	26.9	18.9	1.53	32.1	17.6	3.0	950	34.7	1.90	28.2	103.8	5.36	3.9
85	4.0	1.0	2.4	730	24.2	16.3	1.68	29.9	14.4	3.9	820	33.5	1.96	26.8	107.9	5.01	3.7
	4.0	1.0	2.4	850	24.7	17.8	1.75	30.7	14.1	4.0	950	34.2	1.88	27.8	103.3	5.33	3.8
	6.0	2.1	4.9	730	25.0	16.7	1.59	30.4	15.7	3.6	820	34.7	2.00	27.8	109.1	5.08	3.9
	6.0	2.1	4.9	850	25.6	18.3	1.66	31.3	15.4	3.7	950	35.3	1.92	28.8	104.4	5.40	3.9
	8.0	3.4	7.9	730	25.4	16.8	1.55	30.7	16.5	3.3	820	35.2	2.02	28.4	109.8	5.12	4.0
	8.0	3.4	7.9	850	26.0	18.5	1.61	31.5	16.1	3.4	950	35.9	1.93	29.3	105.0	5.44	4.1
90	4.0	1.0	2.3	730	23.3	15.9	1.77	29.4	13.2	4.5	820	34.7	2.00	27.9	109.2	5.09	3.9
	4.0	1.0	2.3	850	23.9	17.4	1.84	30.2	13.0	4.6	950	35.4	1.92	28.8	104.5	5.41	3.9
	6.0	2.1	4.8	730	24.2	16.3	1.67	29.9	14.4	4.1	820	35.9	2.04	28.9	110.5	5.16	4.0
	6.0	2.1	4.8	850	24.7	17.9	1.75	30.7	14.2	4.2	950	36.6	1.95	29.9	105.6	5.48	4.1
	8.0	3.4	7.8	730	24.6	16.5	1.63	30.2	15.1	3.8	820	36.5	2.06	29.4	111.2	5.19	4.2
	8.0	3.4	7.8	850	25.2	18.1	1.70	31.0	14.8	3.9	950	37.2	1.97	30.4	106.2	5.52	4.3
100	4.0	1.0	2.2	730	21.7	15.2	1.97	28.4	11.0	4.9	Operation not recommended						
	4.0	1.0	2.2	850	22.2	16.7	2.05	29.2	10.8	5.0	Operation not recommended						
	6.0	2.0	4.6	730	22.5	15.5	1.86	28.9	12.1	4.7	Operation not recommended						
	6.0	2.0	4.6	850	23.0	17.0	1.95	29.7	11.8	4.8	Operation not recommended						
	8.0	3.2	7.4	730	22.9	15.7	1.81	29.1	12.6	4.5	Operation not recommended						
	8.0	3.2	7.4	850	23.4	17.2	1.89	29.9	12.4	4.6	Operation not recommended						
110	4.0	0.9	2.1	730	20.1	14.6	2.19	27.7	9.2	5.8	Operation not recommended						
	4.0	0.9	2.1	850	20.6	16.0	2.29	28.4	9.0	6.0	Operation not recommended						
	6.0	1.9	4.4	730	20.9	14.8	2.08	28.0	10.0	5.6	Operation not recommended						
	6.0	1.9	4.4	850	21.3	16.3	2.17	28.8	9.8	5.8	Operation not recommended						
	8.0	3.1	7.2	730	21.2	15.0	2.03	28.2	10.5	5.4	Operation not recommended						
	8.0	3.1	7.2	850	21.7	16.4	2.11	29.0	10.3	5.5	Operation not recommended						
120	4.0	0.9	2.0	730	18.8	14.1	2.45	27.2	7.7	6.9	Operation not recommended						
	4.0	0.9	2.0	850	19.2	15.5	2.55	28.0	7.5	7.1	Operation not recommended						
	6.0	1.8	4.2	730	19.4	14.3	2.32	27.4	8.3	6.7	Operation not recommended						
	6.0	1.8	4.2	850	19.8	15.7	2.43	28.2	8.2	6.8	Operation not recommended						
	8.0	3.0	6.9	730	19.7	14.4	2.26	27.5	8.7	6.4	Operation not recommended						
	8.0	3.0	6.9	850	20.2	15.8	2.36	28.3	8.5	6.5	Operation not recommended						

Interpolation is permissible; extrapolation is not.
 All entering air conditions are 80°F DB and 67°F WB in cooling, and 70°F DB in heating.
 AHRI/ISO certified conditions are 80.6°F DB and 66.2°F WB in cooling and 68°F DB in heating.
 Table does not reflect fan or pump power corrections for AHRI/ISO conditions.
 All performance is based upon the lower voltage of dual voltage rated units.
 Operation below 40°F EWT is based upon a 15% methanol antifreeze solution.
 Operation below 60°F EWT requires optional insulated water/refrigerant circuit.
 See performance correction tables for operating conditions other than those listed above.
 For operation in the shaded areas, please see the Performance Data Selection Notes.

Tranquility 27® (TT) Series

Performance Data — Tranquility 27® Model 038 - Part Load

1000 CFM Nominal (Rated) Airflow Cooling, 1000 CFM Nominal (Rated) Airflow Heating

Performance capacities shown in thousands of Btu/h

EWT °F	GPM	WPD		Cooling - EAT 80/67°F							Heating - EAT 70°F						
		PSI	FT	Airflow CFM	TC	SC	kW	HR	EER	HW	Airflow CFM	HC	kW	HE	LAT	COP	HW
20	8.0	4.7	10.9	Operation not recommended							860	17.5	1.60	12.4	88.9	3.21	1.9
	8.0	4.7	10.9	Operation not recommended							1000	17.7	1.55	12.6	86.4	3.34	1.9
30	4.0	1.2	2.8	860	30.4	19.2	0.79	33.0	38.3	0.5	860	19.3	1.61	14.1	90.8	3.52	2.1
	4.0	1.2	2.8	1000	30.8	20.2	0.80	33.5	38.3	0.5	1000	19.5	1.56	14.4	88.1	3.67	2.1
	6.0	2.6	6.1	860	30.7	19.2	0.75	33.2	40.9	0.5	860	20.0	1.61	14.8	91.5	3.64	2.2
	6.0	2.6	6.1	1000	31.1	20.2	0.76	33.6	40.9	0.5	1000	20.2	1.56	15.1	88.7	3.79	2.2
	8.0	4.5	10.4	860	30.9	19.3	0.73	33.3	42.2	0.4	860	20.4	1.61	15.2	91.9	3.70	2.3
	8.0	4.5	10.4	1000	31.3	20.3	0.74	33.8	42.2	0.5	1000	20.6	1.57	15.5	89.1	3.85	2.3
40	4.0	1.1	2.5	860	31.1	20.8	0.90	34.1	34.5	0.8	860	22.0	1.62	16.8	93.7	3.98	2.3
	4.0	1.1	2.5	1000	31.6	21.8	0.91	34.6	34.5	0.8	1000	22.3	1.57	17.1	90.6	4.15	2.3
	6.0	2.6	5.9	860	31.3	20.8	0.84	34.2	37.3	0.7	860	22.9	1.63	17.6	94.6	4.12	2.4
	6.0	2.6	5.9	1000	31.8	21.9	0.85	34.6	37.3	0.7	1000	23.1	1.58	18.0	91.4	4.30	2.4
	8.0	4.4	10.2	860	31.5	20.8	0.81	34.2	38.8	0.7	860	23.3	1.63	18.1	95.1	4.20	2.5
	8.0	4.4	10.2	1000	32.0	21.9	0.82	34.7	38.8	0.7	1000	23.6	1.58	18.4	91.9	4.37	2.5
50	4.0	1.0	2.2	860	30.9	21.4	1.04	34.4	29.8	1.2	860	24.9	1.64	19.6	96.8	4.45	2.4
	4.0	1.0	2.2	1000	31.3	22.5	1.05	34.8	29.8	1.2	1000	25.2	1.59	20.0	93.3	4.64	2.5
	6.0	2.5	5.7	860	31.2	21.6	0.96	34.4	32.6	1.1	860	25.9	1.64	20.6	97.9	4.62	2.5
	6.0	2.5	5.7	1000	31.7	22.7	0.97	34.9	32.6	1.1	1000	26.2	1.60	21.0	94.3	4.81	2.6
	8.0	4.2	9.7	860	31.4	21.6	0.92	34.5	34.1	1.0	860	26.5	1.65	21.1	98.5	4.70	2.6
	8.0	4.2	9.7	1000	31.8	22.7	0.93	35.0	34.1	1.0	1000	26.8	1.60	21.5	94.8	4.89	2.6
60	4.0	0.9	2.0	860	29.7	21.5	1.19	33.8	25.0	2.5	860	27.8	1.66	22.5	100.0	4.93	2.7
	4.0	0.9	2.0	1000	30.2	22.6	1.21	34.2	25.0	2.6	1000	28.1	1.61	22.9	96.1	5.13	2.7
	6.0	2.4	5.5	860	30.4	21.7	1.10	34.2	27.7	2.3	860	29.0	1.66	23.7	101.3	5.12	2.8
	6.0	2.4	5.5	1000	30.9	22.8	1.11	34.6	27.7	2.3	1000	29.4	1.62	24.1	97.2	5.33	2.8
	8.0	4.1	9.5	860	30.7	21.7	1.06	34.3	29.1	2.0	860	29.7	1.67	24.3	102.0	5.22	2.9
	8.0	4.1	9.5	1000	31.2	22.8	1.07	34.8	29.1	2.0	1000	30.0	1.62	24.8	97.8	5.44	2.9
70	4.0	0.8	1.8	860	28.2	20.9	1.37	32.8	20.6	2.2	860	30.9	1.68	25.4	103.2	5.40	2.9
	4.0	0.8	1.8	1000	28.6	22.0	1.39	33.3	20.6	2.3	1000	31.2	1.63	25.9	98.9	5.63	3.0
	6.0	2.3	5.3	860	29.1	21.3	1.27	33.4	23.0	2.0	860	32.3	1.68	26.8	104.8	5.62	3.1
	6.0	2.3	5.3	1000	29.5	22.4	1.28	33.8	23.0	2.1	1000	32.7	1.64	27.4	100.3	5.85	3.1
	8.0	4.0	9.2	860	29.5	21.4	1.22	33.6	24.3	1.8	860	33.1	1.69	27.6	105.6	5.74	3.2
	8.0	4.0	9.2	1000	29.9	22.5	1.23	34.1	24.3	1.8	1000	33.5	1.64	28.1	101.0	5.98	3.2
80	4.0	0.7	1.7	860	26.4	20.1	1.56	31.7	16.9	2.8	860	34.0	1.70	28.5	106.7	5.88	3.2
	4.0	0.7	1.7	1000	26.8	21.2	1.59	32.2	16.9	2.9	1000	34.4	1.65	29.1	101.9	6.13	3.2
	6.0	2.3	5.2	860	27.4	20.6	1.45	32.3	18.8	2.6	860	35.7	1.71	30.2	108.4	6.13	3.3
	6.0	2.3	5.2	1000	27.8	21.6	1.47	32.8	18.8	2.7	1000	36.1	1.66	30.7	103.4	6.38	3.3
	8.0	3.9	9.0	860	27.9	20.8	1.40	32.6	19.9	2.4	860	36.6	1.71	31.0	109.4	6.27	3.4
	8.0	3.9	9.0	1000	28.3	21.8	1.42	33.1	19.9	2.5	1000	37.0	1.66	31.7	104.3	6.53	3.4
85	4.0	0.7	1.6	860	25.5	19.7	1.67	31.2	15.3	3.4	860	35.7	1.71	30.1	108.4	6.13	3.3
	4.0	0.7	1.6	1000	25.9	20.8	1.70	31.7	15.3	3.5	1000	36.1	1.66	30.7	103.4	6.38	3.3
	6.0	2.2	5.1	860	26.5	20.2	1.56	31.8	17.0	3.1	860	37.5	1.72	31.9	110.3	6.39	3.4
	6.0	2.2	5.1	1000	26.9	21.2	1.58	32.2	17.0	3.2	1000	37.9	1.67	32.5	105.1	6.66	3.4
	8.0	3.8	8.8	860	27.0	20.4	1.50	32.1	17.9	2.9	860	38.5	1.73	32.8	111.4	6.54	3.5
	8.0	3.8	8.8	1000	27.4	21.4	1.53	32.5	17.9	3.0	1000	38.9	1.67	33.5	106.0	6.81	3.6
90	4.0	0.7	1.5	860	24.7	19.3	1.79	30.7	13.8	3.8	860	37.3	1.72	31.7	110.2	6.37	3.4
	4.0	0.7	1.5	1000	25.0	20.3	1.81	31.2	13.8	3.9	1000	37.7	1.67	32.3	104.9	6.63	3.4
	6.0	2.1	4.9	860	25.6	19.7	1.67	31.2	15.3	3.6	860	39.2	1.73	33.6	112.2	6.65	3.5
	6.0	2.1	4.9	1000	25.9	20.8	1.69	31.7	15.3	3.6	1000	39.7	1.68	34.2	106.7	6.92	3.5
	8.0	3.7	8.5	860	26.1	20.0	1.61	31.5	16.2	3.3	860	40.3	1.74	34.6	113.4	6.80	3.6
	8.0	3.7	8.5	1000	26.4	21.0	1.63	32.0	16.2	3.4	1000	40.8	1.69	35.3	107.7	7.08	3.7
100	4.0	0.6	1.4	860	23.1	18.8	2.03	30.0	11.4	4.5	Operation not recommended						
	4.0	0.6	1.4	1000	23.4	19.7	2.06	30.4	11.4	4.6	Operation not recommended						
	6.0	2.1	4.8	860	23.8	19.0	1.90	30.3	12.5	4.4	Operation not recommended						
	6.0	2.1	4.8	1000	24.2	20.0	1.93	30.8	12.5	4.4	Operation not recommended						
	8.0	3.6	8.3	860	24.3	19.2	1.84	30.5	13.2	4.2	Operation not recommended						
	8.0	3.6	8.3	1000	24.6	20.2	1.87	31.0	13.2	4.3	Operation not recommended						
110	4.0	0.6	1.3	860	21.9	18.6	2.30	29.7	9.5	5.8	Operation not recommended						
	4.0	0.6	1.3	1000	22.2	19.6	2.34	30.2	9.5	5.9	Operation not recommended						
	6.0	2.0	4.6	860	22.4	18.6	2.16	29.8	10.4	5.6	Operation not recommended						
	6.0	2.0	4.6	1000	22.7	19.6	2.19	30.2	10.4	5.7	Operation not recommended						
	8.0	3.4	7.9	860	22.7	18.7	2.10	29.9	10.8	5.4	Operation not recommended						
	8.0	3.4	7.9	1000	23.0	19.6	2.13	30.3	10.8	5.5	Operation not recommended						
120	4.0	0.5	1.2	860	21.0	18.2	2.58	29.9	8.2	7.3	Operation not recommended						
	4.0	0.5	1.2	1000	21.3	19.2	2.61	30.3	8.2	7.5	Operation not recommended						
	6.0	1.9	4.5	860	21.5	18.6	2.45	29.9	8.8	7.0	Operation not recommended						
	6.0	1.9	4.5	1000	21.8	19.6	2.49	30.3	8.8	7.2	Operation not recommended						
	8.0	3.3	7.7	860	21.7	18.7	2.41	29.9	9.0	6.8	Operation not recommended						
	8.0	3.3	7.7	1000	22.0	19.7	2.45	30.3	9.0	6.9	Operation not recommended						

Interpolation is permissible; extrapolation is not.
 All entering air conditions are 80°F DB and 67°F WB in cooling, and 70°F DB in heating.
 AHRI/ISO certified conditions are 80.6°F DB and 66.2°F WB in cooling and 68°F DB in heating.
 Table does not reflect fan or pump power corrections for AHRI/ISO conditions.
 All performance is based upon the lower voltage of dual voltage rated units.
 Operation below 40°F EWT is based upon a 15% methanol antifreeze solution.
 Operation below 60°F EWT requires optional insulated water/refrigerant circuit.
 See performance correction tables for operating conditions other than those listed above.
 For operation in the shaded areas, please see the Performance Data Selection Notes.

Performance Data — Tranquility27® Model 038 - Full Load

1250 CFM Nominal (Rated) Airflow Cooling, 1250 CFM Nominal (Rated) Airflow Heating

Performance capacities shown in thousands of Btu/h

EWT °F	GPM	WPD		Cooling - EAT 80/67°F							Heating - EAT 70°F						
		PSI	FT	Airflow CFM	TC	SC	kW	HR	EER	HW	Airflow CFM	HC	kW	HE	LAT	COP	HW
20	9.0	5.9	13.7	Operation not recommended							1080	25.7	2.28	18.2	92.0	3.30	2.2
	9.0	5.9	13.7								1250	26.2	2.18	18.8	89.4	3.51	2.3
30	4.5	1.7	3.9	1080	43.1	27.4	1.55	48.3	27.9	0.6	1080	27.9	2.32	20.2	93.9	3.52	2.7
	4.5	1.7	3.9	1250	44.1	30.1	1.61	49.6	27.3	0.6	1250	28.4	2.22	20.9	91.1	3.75	2.8
	6.8	3.3	7.7	1080	43.3	27.5	1.44	48.1	30.0	0.6	1080	29.2	2.35	21.4	95.0	3.64	2.8
	6.8	3.3	7.7	1250	44.3	30.1	1.51	49.4	29.4	0.6	1250	29.7	2.25	22.1	92.0	3.87	2.9
	9.0	5.7	13.1	1080	43.4	27.5	1.39	48.1	31.2	0.6	1080	29.9	2.36	22.0	95.6	3.71	2.9
	9.0	5.7	13.1	1250	44.4	30.1	1.45	49.4	30.6	0.6	1250	30.4	2.26	22.8	92.5	3.94	3.0
40	4.5	1.5	3.5	1080	42.3	27.5	1.69	48.0	25.0	1.1	1080	31.8	2.40	23.8	97.2	3.88	3.1
	4.5	1.5	3.5	1250	43.3	30.1	1.77	49.4	24.5	1.1	1250	32.4	2.30	24.6	94.0	4.12	3.2
	6.8	3.2	7.4	1080	42.9	27.6	1.59	48.2	27.1	1.0	1080	33.3	2.44	25.2	98.6	4.01	3.3
	6.8	3.2	7.4	1250	43.9	30.2	1.66	49.6	26.5	1.1	1250	33.9	2.34	26.0	95.1	4.26	3.3
	9.0	5.4	12.5	1080	43.1	27.6	1.53	48.3	28.1	0.9	1080	34.1	2.46	25.9	99.3	4.08	3.4
	9.0	5.4	12.5	1250	44.1	30.3	1.60	49.6	27.6	1.0	1250	34.8	2.35	26.8	95.8	4.33	3.4
50	4.5	1.3	3.1	1080	41.1	27.1	1.85	47.4	22.2	1.8	1080	35.7	2.49	27.4	100.6	4.20	3.6
	4.5	1.3	3.1	1250	42.1	29.7	1.93	48.7	21.8	1.8	1250	36.4	2.39	28.3	97.0	4.47	3.6
	6.8	3.1	7.2	1080	42.0	27.4	1.74	47.9	24.2	1.6	1080	37.5	2.54	29.0	102.2	4.34	3.7
	6.8	3.1	7.2	1250	43.0	30.0	1.81	49.2	23.7	1.7	1250	38.3	2.43	30.0	98.3	4.61	3.8
	9.0	5.2	12.0	1080	42.4	27.5	1.68	48.1	25.2	1.5	1080	38.5	2.56	29.9	103.0	4.41	3.9
	9.0	5.2	12.0	1250	43.4	30.1	1.75	49.4	24.8	1.5	1250	39.3	2.46	30.9	99.1	4.68	3.9
60	4.5	1.2	2.8	1080	39.6	26.4	2.02	46.4	19.6	2.5	1080	39.8	2.60	31.0	104.1	4.50	4.1
	4.5	1.2	2.8	1250	40.5	29.0	2.11	47.7	19.2	2.6	1250	40.6	2.49	32.1	100.1	4.78	4.1
	6.8	3.0	6.9	1080	40.7	26.9	1.90	47.1	21.4	2.3	1080	41.9	2.65	32.9	105.9	4.63	4.2
	6.8	3.0	6.9	1250	41.7	29.5	1.98	48.4	21.0	2.3	1250	42.7	2.54	34.1	101.6	4.92	4.3
	9.0	5.0	11.6	1080	41.2	27.1	1.84	47.4	22.4	2.0	1080	43.1	2.69	34.0	106.9	4.70	4.4
	9.0	5.0	11.6	1250	42.2	29.7	1.92	48.7	22.0	2.0	1250	43.9	2.58	35.1	102.5	5.00	4.4
70	4.5	1.1	2.5	1080	37.8	25.7	2.22	45.3	17.0	3.4	1080	44.0	2.71	34.8	107.7	4.75	4.5
	4.5	1.1	2.5	1250	38.7	28.2	2.32	46.6	16.7	3.5	1250	44.8	2.60	36.0	103.2	5.05	4.6
	6.8	2.9	6.7	1080	39.1	26.2	2.08	46.1	18.8	3.0	1080	46.4	2.79	36.9	109.8	4.88	4.7
	6.8	2.9	6.7	1250	40.0	28.8	2.17	47.4	18.4	3.1	1250	47.3	2.67	38.2	105.0	5.19	4.8
	9.0	4.8	11.0	1080	39.7	26.5	2.01	46.5	19.7	2.7	1080	47.8	2.83	38.2	111.0	4.95	4.9
	9.0	4.8	11.0	1250	40.6	29.0	2.10	47.8	19.3	2.7	1250	48.7	2.71	39.5	106.1	5.27	5.0
80	4.5	1.0	2.3	1080	35.8	24.8	2.44	44.2	14.7	4.0	1080	48.3	2.84	38.6	111.4	4.98	5.0
	4.5	1.0	2.3	1250	36.7	27.2	2.55	45.4	14.4	4.1	1250	49.2	2.73	39.9	106.5	5.29	5.0
	6.8	2.8	6.6	1080	37.2	25.4	2.29	45.0	16.3	3.7	1080	51.1	2.93	41.1	113.8	5.10	5.2
	6.8	2.8	6.6	1250	38.0	27.9	2.39	46.2	15.9	3.8	1250	52.1	2.81	42.5	108.6	5.43	5.2
	9.0	4.5	10.4	1080	37.8	25.7	2.21	45.4	17.1	3.4	1080	52.7	2.99	42.4	115.1	5.17	5.4
	9.0	4.5	10.4	1250	38.7	28.2	2.31	46.6	16.8	3.5	1250	53.7	2.86	43.9	109.8	5.50	5.4
85	4.5	1.0	2.2	1080	34.8	24.3	2.57	43.6	13.6	4.5	1080	50.5	2.92	40.6	113.3	5.08	5.2
	4.5	1.0	2.2	1250	35.6	26.7	2.68	44.8	13.3	4.6	1250	51.5	2.80	41.9	108.1	5.40	5.3
	6.8	2.8	6.4	1080	36.2	25.0	2.40	44.4	15.0	4.2	1080	53.5	3.02	43.2	115.9	5.20	5.4
	6.8	2.8	6.4	1250	37.0	27.4	2.51	45.6	14.7	4.3	1250	54.5	2.89	44.7	110.4	5.53	5.5
	9.0	4.5	10.3	1080	36.8	25.3	2.33	44.8	15.8	3.9	1080	55.2	3.07	44.7	117.3	5.26	5.6
	9.0	4.5	10.3	1250	37.7	27.7	2.43	46.0	15.5	3.9	1250	56.3	2.95	46.2	111.7	5.59	5.7
90	4.5	0.9	2.1	1080	33.8	23.9	2.70	43.0	12.5	5.2	1080	52.7	2.99	42.5	115.2	5.17	5.4
	4.5	0.9	2.1	1250	34.6	26.2	2.81	44.2	12.3	5.3	1250	53.7	2.86	44.0	109.8	5.50	5.5
	6.8	2.7	6.2	1080	35.1	24.5	2.52	43.8	13.9	4.8	1080	55.9	3.10	45.3	117.9	5.29	5.6
	6.8	2.7	6.2	1250	36.0	26.9	2.63	45.0	13.7	4.9	1250	57.0	2.97	46.9	112.2	5.62	5.7
	9.0	4.4	10.2	1080	35.8	24.8	2.44	44.2	14.7	4.4	1080	57.7	3.16	46.9	119.5	5.35	5.8
	9.0	4.4	10.2	1250	36.7	27.2	2.55	45.4	14.4	4.5	1250	58.8	3.03	48.5	113.6	5.69	5.9
100	4.5	0.8	1.9	1080	31.8	22.9	2.99	42.0	10.6	5.7	Operation not recommended						
	4.5	0.8	1.9	1250	32.5	25.2	3.12	43.2	10.4	5.8							
	6.8	2.6	6.1	1080	33.1	23.5	2.80	42.6	11.8	5.5							
	6.8	2.6	6.1	1250	33.8	25.8	2.92	43.8	11.6	5.6							
	9.0	4.2	9.7	1080	33.7	23.9	2.70	43.0	12.5	5.3							
	9.0	4.2	9.7	1250	34.5	26.2	2.82	44.2	12.2	5.4							
110	4.5	0.8	1.8	1080	29.8	22.1	3.34	41.3	8.9	6.8	Operation not recommended						
	4.5	0.8	1.8	1250	30.5	24.2	3.49	42.4	8.7	7.0							
	6.8	2.5	5.9	1080	31.0	22.6	3.12	41.7	10.0	6.6							
	6.8	2.5	5.9	1250	31.7	24.8	3.25	42.9	9.8	6.7							
	9.0	4.0	9.2	1080	31.7	22.9	3.01	42.0	10.5	6.3							
	9.0	4.0	9.2	1250	32.4	25.1	3.14	43.1	10.3	6.5							
120	4.5	0.7	1.6	1080	28.0	21.3	3.74	40.9	7.5	8.1	Operation not recommended						
	4.5	0.7	1.6	1250	28.7	23.3	3.91	42.0	7.3	8.2							
	6.8	2.5	5.9	1080	29.1	21.7	3.49	41.1	8.3	7.8							
	6.8	2.5	5.9	1250	29.8	23.8	3.64	42.2	8.2	7.9							
	9.0	3.8	8.8	1080	29.7	22.0	3.36	41.2	8.8	7.5							
	9.0	3.8	8.8	1250	30.4	24.1	3.51	42.4	8.6	7.6							

Interpolation is permissible; extrapolation is not.
 All entering air conditions are 80°F DB and 67°F WB in cooling, and 70°F DB in heating.
 AHR/ISO certified conditions are 80.6°F DB and 66.2°F WB in cooling and 68°F DB in heating.
 Table does not reflect fan or pump power corrections for AHR/ISO conditions.
 All performance is based upon the lower voltage of dual voltage rated units.
 Operation below 40°F EWT is based upon a 15% methanol antifreeze solution.
 Operation below 60°F EWT requires optional insulated water/refrigerant circuit.
 See performance correction tables for operating conditions other than those listed above.
 For operation in the shaded areas, please see the Performance Data Selection Notes.

Tranquility 27® (TT) Series

Performance Data — Tranquility 27® Model 049 - Part Load

1300 CFM Nominal (Rated) Airflow Cooling, 1400 CFM Nominal (Rated) Airflow Heating

Performance capacities shown in thousands of Btu/h

EWT °F	GPM	WPD		Cooling - EAT 80/67°F							Heating - EAT 70°F						
		PSI	FT	Airflow CFM	TC	SC	kW	HR	EER	HW	Airflow CFM	HC	kW	HE	LAT	COP	HW
20	11.0	4.0	9.3	Operation not recommended							1200	23.2	2.16	16.2	87.9	3.14	2.3
	11.0	4.0	9.3								1400	23.5	2.10	16.6	85.5	3.27	2.3
30	5.5	1.1	2.5	1120	38.6	24.0	1.20	42.6	32.0	0.6	1200	25.6	2.20	18.6	89.8	3.42	2.5
	5.5	1.1	2.5	1300	39.1	25.2	1.22	43.3	32.0	0.6	1400	25.9	2.14	18.9	87.2	3.56	2.5
	8.3	2.3	5.2	1120	38.8	24.0	1.14	42.6	34.2	0.5	1200	26.6	2.21	19.4	90.5	3.52	2.6
	8.3	2.3	5.2	1300	39.4	25.3	1.15	43.2	34.2	0.6	1400	26.9	2.15	19.8	87.8	3.67	2.6
	11.0	3.9	8.9	1120	39.0	24.0	1.10	42.7	35.4	0.5	1200	27.1	2.22	19.9	90.9	3.58	2.7
	11.0	3.9	8.9	1300	39.6	25.2	1.12	43.3	35.4	0.5	1400	27.4	2.15	20.3	88.1	3.73	2.7
40	5.5	1.0	2.3	1120	40.8	26.2	1.37	45.5	29.9	1.0	1200	29.6	2.24	22.4	92.9	3.88	2.7
	5.5	1.0	2.3	1300	41.4	27.6	1.38	46.1	29.9	1.0	1400	30.0	2.18	22.9	89.8	4.04	2.8
	8.3	2.2	5.0	1120	41.2	26.3	1.28	45.5	32.1	0.9	1200	30.9	2.25	23.6	93.8	4.02	2.8
	8.3	2.2	5.0	1300	41.8	27.6	1.30	46.2	32.1	1.0	1400	31.2	2.19	24.1	90.7	4.19	2.9
	11.0	3.7	8.6	1120	41.3	26.3	1.25	45.5	32.9	0.9	1200	31.6	2.26	24.3	94.4	4.10	2.9
	11.0	3.7	8.6	1300	41.9	27.6	1.27	46.1	32.9	0.9	1400	31.9	2.19	24.8	91.1	4.27	3.0
50	5.5	0.9	2.1	1120	40.8	26.8	1.49	45.9	27.3	1.6	1200	34.0	2.28	26.7	96.3	4.38	2.9
	5.5	0.9	2.1	1300	41.4	28.2	1.51	46.5	27.3	1.7	1400	34.4	2.21	27.2	92.8	4.56	2.9
	8.3	2.1	4.9	1120	41.2	26.9	1.41	45.9	29.1	1.5	1200	35.6	2.29	28.2	97.5	4.56	3.0
	8.3	2.1	4.9	1300	41.7	28.2	1.43	46.6	29.1	1.5	1400	36.0	2.23	28.8	93.8	4.74	3.0
	11.0	3.6	8.3	1120	41.3	26.9	1.40	46.0	29.4	1.3	1200	36.5	2.30	29.1	98.2	4.65	3.1
	11.0	3.6	8.3	1300	41.9	28.3	1.42	46.7	29.4	1.4	1400	36.9	2.23	29.6	94.4	4.85	3.2
60	5.5	0.8	2.0	1120	40.0	27.1	1.73	45.9	23.2	3.5	1200	38.7	2.32	31.2	99.8	4.89	3.2
	5.5	0.8	2.0	1300	40.6	28.5	1.75	46.5	23.2	3.6	1400	39.1	2.25	31.8	95.9	5.09	3.3
	8.3	2.0	4.7	1120	40.7	27.2	1.62	46.2	25.1	3.2	1200	40.6	2.33	33.0	101.3	5.10	3.3
	8.3	2.0	4.7	1300	41.3	28.6	1.64	46.9	25.1	3.2	1400	41.1	2.27	33.7	97.2	5.31	3.4
	11.0	3.5	8.1	1120	41.0	27.2	1.57	46.3	26.1	2.8	1200	41.7	2.34	34.1	102.1	5.21	3.5
	11.0	3.5	8.1	1300	41.5	28.7	1.59	46.9	26.1	2.9	1400	42.1	2.27	34.7	97.9	5.43	3.5
70	5.5	0.8	1.8	1120	38.2	26.5	1.94	44.8	19.7	3.1	1200	43.4	2.36	35.7	103.5	5.39	3.5
	5.5	0.8	1.8	1300	38.8	27.9	1.97	45.4	19.7	3.2	1400	43.9	2.29	36.4	99.0	5.62	3.6
	8.3	2.0	4.6	1120	39.3	26.9	1.82	45.5	21.6	2.8	1200	45.6	2.38	37.9	105.2	5.62	3.7
	8.3	2.0	4.6	1300	39.9	28.3	1.85	46.1	21.6	2.9	1400	46.1	2.31	38.6	100.5	5.85	3.7
	11.0	3.3	7.5	1120	39.8	27.1	1.76	45.7	22.6	2.5	1200	46.8	2.39	39.0	106.1	5.73	3.8
	11.0	3.3	7.5	1300	40.3	28.4	1.79	46.4	22.6	2.5	1400	47.3	2.32	39.7	101.3	5.97	3.9
80	5.5	0.7	1.7	1120	35.9	25.7	2.17	43.3	16.5	4.0	1200	48.0	2.40	40.2	107.1	5.86	3.8
	5.5	0.7	1.7	1300	36.5	27.0	2.20	43.9	16.5	4.1	1400	48.6	2.33	41.0	102.1	6.10	3.8
	8.3	1.9	4.5	1120	37.2	26.2	2.04	44.2	18.2	3.7	1200	50.4	2.43	42.5	108.9	6.07	3.9
	8.3	1.9	4.5	1300	37.7	27.5	2.07	44.8	18.2	3.8	1400	50.9	2.36	43.3	103.7	6.33	4.0
	11.0	3.2	7.3	1120	37.8	26.4	1.98	44.6	19.1	3.4	1200	51.6	2.45	43.7	109.8	6.18	4.1
	11.0	3.2	7.3	1300	38.4	27.8	2.01	45.2	19.1	3.5	1400	52.2	2.38	44.5	104.5	6.44	4.1
85	5.5	0.7	1.7	1120	34.7	25.2	2.30	42.5	15.0	4.8	1200	50.2	2.43	42.3	108.8	6.06	3.9
	5.5	0.7	1.7	1300	35.2	26.5	2.34	43.1	15.0	5.0	1400	50.8	2.36	43.1	103.6	6.31	4.0
	8.3	1.9	4.3	1120	36.0	25.7	2.17	43.4	16.6	4.5	1200	52.6	2.46	44.6	110.6	6.26	4.1
	8.3	1.9	4.3	1300	36.5	27.0	2.20	44.0	16.6	4.6	1400	53.2	2.39	45.4	105.2	6.52	4.1
	11.0	3.1	7.3	1120	36.6	25.9	2.10	43.8	17.4	4.1	1200	53.8	2.48	45.7	111.5	6.35	4.2
	11.0	3.1	7.3	1300	37.1	27.3	2.13	44.4	17.4	4.2	1400	54.4	2.41	46.6	106.0	6.62	4.3
90	5.5	0.7	1.6	1120	33.4	24.7	2.44	41.7	13.7	5.5	1200	52.4	2.46	44.4	110.5	6.25	4.0
	5.5	0.7	1.6	1300	33.9	25.9	2.47	42.3	13.7	5.6	1400	53.0	2.39	45.3	105.1	6.51	4.1
	8.3	1.8	4.2	1120	34.7	25.2	2.30	42.6	15.1	5.1	1200	54.8	2.50	46.7	112.3	6.44	4.2
	8.3	1.8	4.2	1300	35.2	26.5	2.33	43.2	15.1	5.2	1400	55.4	2.42	47.6	106.7	6.70	4.3
	11.0	3.1	7.2	1120	35.4	25.5	2.23	43.0	15.9	4.7	1200	56.0	2.52	47.8	113.2	6.52	4.4
	11.0	3.1	7.2	1300	35.9	26.8	2.26	43.6	15.9	4.8	1400	56.7	2.45	48.8	107.5	6.79	4.4
100	5.5	0.7	1.5	1120	30.9	23.7	2.73	40.2	11.3	6.5	Operation not recommended						
	5.5	0.7	1.5	1300	31.3	24.9	2.77	40.7	11.3	6.6							
	8.3	1.8	4.1	1120	32.1	24.2	2.58	40.9	12.5	6.3							
	8.3	1.8	4.1	1300	32.6	25.4	2.62	41.5	12.5	6.4							
	11.0	3.0	6.8	1120	32.8	24.4	2.50	41.3	13.1	6.0							
	11.0	3.0	6.8	1300	33.3	25.7	2.54	41.9	13.1	6.2							
110	5.5	0.6	1.5	1120	28.5	22.9	3.07	39.0	9.3	8.4	Operation not recommended						
	5.5	0.6	1.5	1300	28.9	24.1	3.11	39.6	9.3	8.5							
	8.3	1.7	4.0	1120	29.6	23.3	2.90	39.5	10.2	8.0							
	8.3	1.7	4.0	1300	30.0	24.5	2.94	40.1	10.2	8.2							
	11.0	2.8	6.6	1120	30.2	23.5	2.82	39.8	10.7	7.7							
	11.0	2.8	6.6	1300	30.6	24.7	2.86	40.4	10.7	7.9							
120	5.5	0.6	1.4	1120	26.7	22.7	3.45	38.4	7.7	10.6	Operation not recommended						
	5.5	0.6	1.4	1300	27.0	23.8	3.50	39.0	7.7	10.8							
	8.3	1.7	3.8	1120	27.5	22.7	3.26	38.6	8.4	10.2							
	8.3	1.7	3.8	1300	27.9	23.9	3.31	39.2	8.4	10.4							
	11.0	2.7	6.3	1120	27.9	22.8	3.17	38.8	8.8	9.8							
	11.0	2.7	6.3	1300	28.3	24.0	3.22	39.3	8.8	10.0							

Interpolation is permissible; extrapolation is not.
 All entering air conditions are 80°F DB and 67°F WB in cooling, and 70°F DB in heating.
 AHRI/ISO certified conditions are 80.6°F DB and 66.2°F WB in cooling and 68°F DB in heating.
 Table does not reflect fan or pump power corrections for AHRI/ISO conditions.
 All performance is based upon the lower voltage of dual voltage rated units.
 Operation below 40°F EWT is based upon a 15% methanol antifreeze solution.
 Operation below 60°F EWT requires optional insulated water/refrigerant circuit.
 See performance correction tables for operating conditions other than those listed above.
 For operation in the shaded areas, please see the Performance Data Selection Notes.

Performance Data — Tranquility27® Model 049 - Full Load

1550 CFM Nominal (Rated) Airflow Cooling, 1650 CFM Nominal (Rated) Airflow Heating

Performance capacities shown in thousands of Btu/h

EWT °F	GPM	WPD		Cooling - EAT 80/67°F							Heating - EAT 70°F						
		PSI	FT	Airflow CFM	TC	SC	kW	HR	EER	HW	Airflow CFM	HC	kW	HE	LAT	COP	HW
20	12.0	4.8	11.0	Operation not recommended							1430	31.6	2.90	22.1	90.5	3.20	2.7
	12.0	4.8	11.0								1650	32.3	2.78	22.9	88.1	3.40	2.7
30	6.0	1.3	2.9	1330	56.1	32.1	2.13	63.2	26.4	0.8	1430	34.7	2.98	24.9	92.5	3.41	3.2
	6.0	1.3	2.9	1550	57.4	35.1	2.22	65.0	25.9	0.8	1650	35.4	2.86	25.7	89.9	3.62	3.3
	9.0	2.7	6.1	1330	56.5	32.1	2.01	63.2	28.2	0.7	1430	36.3	3.03	26.3	93.5	3.51	3.4
	9.0	2.7	6.1	1550	57.9	35.2	2.09	65.0	27.6	0.7	1650	37.0	2.90	27.2	90.8	3.73	3.4
	12.0	4.6	10.5	1330	56.8	32.1	1.94	63.3	29.3	0.7	1430	37.2	3.05	27.0	94.1	3.57	3.5
	12.0	4.6	10.5	1550	58.2	35.2	2.03	65.1	28.7	0.7	1650	37.9	2.93	28.0	91.3	3.79	3.5
40	6.0	1.1	2.7	1330	55.8	33.0	2.32	63.6	24.1	1.5	1430	40.0	3.13	29.6	95.9	3.75	3.8
	6.0	1.1	2.7	1550	57.1	36.2	2.42	65.4	23.6	1.5	1650	40.8	3.00	30.6	92.9	3.99	3.8
	9.0	2.6	5.9	1330	56.4	33.0	2.19	63.7	25.8	1.4	1430	42.0	3.18	31.4	97.2	3.87	3.9
	9.0	2.6	5.9	1550	57.7	36.2	2.28	65.5	25.3	1.4	1650	42.8	3.05	32.4	94.0	4.11	4.0
	12.0	4.4	10.1	1330	56.6	33.0	2.12	63.8	26.7	1.2	1430	43.1	3.21	32.4	97.9	3.94	4.1
	12.0	4.4	10.1	1550	58.0	36.2	2.22	65.5	26.2	1.3	1650	43.9	3.08	33.5	94.6	4.19	4.1
50	6.0	1.1	2.5	1330	54.5	33.3	2.51	63.0	21.8	2.5	1430	45.5	3.27	34.6	99.5	4.08	4.3
	6.0	1.1	2.5	1550	55.8	36.5	2.62	64.7	21.3	2.6	1650	46.4	3.14	35.8	96.0	4.34	4.4
	9.0	2.5	5.7	1330	55.6	33.4	2.37	63.6	23.5	2.3	1430	48.0	3.33	36.8	101.1	4.22	4.5
	9.0	2.5	5.7	1550	56.9	36.6	2.47	65.4	23.0	2.3	1650	48.9	3.20	38.0	97.4	4.48	4.5
	12.0	4.2	9.6	1330	56.0	33.4	2.30	63.7	24.3	2.0	1430	49.3	3.37	38.0	101.9	4.29	4.6
	12.0	4.2	9.6	1550	57.3	36.7	2.40	65.5	23.8	2.0	1650	50.3	3.23	39.3	98.2	4.56	4.7
60	6.0	1.0	2.3	1330	52.5	32.6	2.71	61.7	19.4	3.5	1430	51.3	3.42	39.8	103.2	4.39	4.9
	6.0	1.0	2.3	1550	53.7	35.8	2.82	63.4	19.0	3.6	1650	52.3	3.28	41.1	99.3	4.67	5.0
	9.0	2.4	5.5	1330	54.0	33.1	2.56	62.7	21.1	3.2	1430	54.2	3.50	42.4	105.1	4.54	5.1
	9.0	2.4	5.5	1550	55.3	36.3	2.67	64.4	20.7	3.2	1650	55.2	3.36	43.8	101.0	4.83	5.2
	12.0	4.0	9.2	1330	54.7	33.3	2.49	63.1	21.9	2.8	1430	55.8	3.54	43.8	106.1	4.62	5.3
	12.0	4.0	9.2	1550	55.9	36.5	2.60	64.8	21.5	2.9	1650	56.9	3.40	45.3	101.9	4.91	5.4
70	6.0	0.9	2.2	1330	49.9	31.7	2.93	59.9	17.1	4.8	1430	57.2	3.58	45.1	107.1	4.68	5.5
	6.0	0.9	2.2	1550	51.1	34.8	3.06	61.6	16.7	4.9	1650	58.3	3.44	46.6	102.7	4.98	5.6
	9.0	2.3	5.4	1330	51.7	32.4	2.77	61.1	18.7	4.3	1430	60.6	3.68	48.1	109.2	4.83	5.7
	9.0	2.3	5.4	1550	53.0	35.5	2.89	62.8	18.3	4.4	1650	61.7	3.53	49.7	104.7	5.13	5.8
	12.0	3.8	8.8	1330	52.6	32.7	2.70	61.7	19.5	3.8	1430	62.4	3.73	49.7	110.4	4.90	5.9
	12.0	3.8	8.8	1550	53.8	35.8	2.81	63.4	19.1	3.9	1650	63.6	3.58	51.4	105.7	5.21	6.0
80	6.0	0.9	2.1	1330	47.1	30.6	3.18	57.9	14.8	5.8	1430	63.2	3.76	50.5	111.0	4.94	6.0
	6.0	0.9	2.1	1550	48.2	33.6	3.32	59.5	14.5	5.9	1650	64.5	3.60	52.2	106.2	5.25	6.1
	9.0	2.3	5.2	1330	49.0	31.4	3.01	59.3	16.3	5.4	1430	67.0	3.87	53.8	113.4	5.07	6.2
	9.0	2.3	5.2	1550	50.2	34.4	3.14	60.9	16.0	5.5	1650	68.3	3.71	55.7	108.3	5.39	6.3
	12.0	3.6	8.3	1330	50.0	31.7	2.92	59.9	17.1	4.9	1430	69.1	3.94	55.7	114.8	5.14	6.5
	12.0	3.6	8.3	1550	51.2	34.8	3.05	61.6	16.8	5.0	1650	70.5	3.78	57.6	109.5	5.47	6.6
85	6.0	0.9	2.0	1330	45.5	30.1	3.32	56.9	13.7	6.5	1430	66.3	3.85	53.2	112.9	5.04	6.3
	6.0	0.9	2.0	1550	46.6	33.0	3.47	58.5	13.4	6.7	1650	67.6	3.69	55.0	107.9	5.36	6.4
	9.0	2.2	5.1	1330	47.5	30.8	3.14	58.2	15.1	6.0	1430	70.3	3.98	56.7	115.5	5.18	6.5
	9.0	2.2	5.1	1550	48.6	33.8	3.28	59.8	14.8	6.2	1650	71.6	3.82	58.6	110.2	5.50	6.6
	12.0	3.6	8.2	1330	48.5	31.2	3.05	58.9	15.9	5.5	1430	72.5	4.06	58.6	116.9	5.24	6.8
	12.0	3.6	8.2	1550	49.6	34.2	3.19	60.5	15.6	5.7	1650	73.9	3.89	60.6	111.5	5.57	6.9
90	6.0	0.9	2.0	1330	44.0	29.5	3.47	55.9	12.7	7.5	1430	69.3	3.95	55.8	114.9	5.15	6.5
	6.0	0.9	2.0	1550	45.0	32.4	3.62	57.4	12.4	7.6	1650	70.7	3.78	57.7	109.7	5.47	6.6
	9.0	2.2	5.0	1330	46.0	30.2	3.28	57.2	14.0	6.9	1430	73.5	4.09	59.5	117.6	5.27	6.8
	9.0	2.2	5.0	1550	47.1	33.2	3.42	58.8	13.8	7.1	1650	74.9	3.92	61.6	112.1	5.60	6.9
	12.0	3.5	8.1	1330	47.0	30.6	3.18	57.9	14.8	6.3	1430	75.8	4.17	61.5	119.1	5.33	7.1
	12.0	3.5	8.1	1550	48.1	33.6	3.32	59.5	14.5	6.5	1650	77.3	4.00	63.6	113.4	5.66	7.2
100	6.0	0.8	1.9	1330	40.9	28.5	3.80	53.9	10.7	8.2	Operation not recommended						
	6.0	0.8	1.9	1550	41.8	31.2	3.97	55.4	10.5	8.4							
	9.0	2.1	4.8	1330	42.8	29.1	3.59	55.1	11.9	7.9							
	9.0	2.1	4.8	1550	43.8	31.9	3.74	56.6	11.7	8.1							
	12.0	3.3	7.7	1330	43.8	29.4	3.48	55.8	12.6	7.6							
	12.0	3.3	7.7	1550	44.9	32.3	3.64	57.3	12.3	7.8							
110	6.0	0.8	1.8	1330	37.8	27.6	4.19	52.2	9.0	9.9	Operation not recommended						
	6.0	0.8	1.8	1550	38.7	30.2	4.38	53.7	8.8	10.1							
	9.0	2.0	4.7	1330	39.6	28.1	3.95	53.2	10.0	9.5							
	9.0	2.0	4.7	1550	40.6	30.8	4.12	54.7	9.8	9.7							
	12.0	3.2	7.3	1330	40.6	28.4	3.83	53.7	10.6	9.2							
	12.0	3.2	7.3	1550	41.5	31.1	4.00	55.2	10.4	9.4							
120	6.0	0.8	1.7	1330	34.9	27.0	4.65	51.0	7.5	11.7	Operation not recommended						
	6.0	0.8	1.7	1550	35.8	29.6	4.86	52.4	7.4	12.0							
	9.0	2.0	4.5	1330	36.6	27.3	4.37	51.6	8.4	11.3							
	9.0	2.0	4.5	1550	37.4	29.9	4.57	53.1	8.2	11.5							
	12.0	3.0	7.0	1330	37.4	27.5	4.24	52.0	8.8	10.9							
	12.0	3.0	7.0	1550	38.3	30.1	4.43	53.5	8.7	11.1							

Interpolation is permissible; extrapolation is not.
 All entering air conditions are 80°F DB and 67°F WB in cooling, and 70°F DB in heating.
 AHRI/ISO certified conditions are 80.6°F DB and 66.2°F WB in cooling and 68°F DB in heating.
 Table does not reflect fan or pump power corrections for AHRI/ISO conditions.
 All performance is based upon the lower voltage of dual voltage rated units.
 Operation below 40°F EWT is based upon a 15% methanol antifreeze solution.
 Operation below 60°F EWT requires optional insulated water/refrigerant circuit.
 See performance correction tables for operating conditions other than those listed above.
 For operation in the shaded areas, please see the Performance Data Selection Notes.

Performance Data — Tranquility 27® Model 064 - Part Load

1500 CFM Nominal (Rated) Airflow Cooling, 1650 CFM Nominal (Rated) Airflow Heating

Performance capacities shown in thousands of Btuh

EWT °F	GPM	WPD		Cooling - EAT 80/67°F							Heating - EAT 70°F						
		PSI	FT	Airflow CFM	TC	SC	kW	HR	EER	HW	Airflow CFM	HC	kW	HE	LAT	COP	HW
20	14.0	4.1	9.4	Operation not recommended							1430	28.7	2.85	19.5	88.6	2.95	2.4
	14.0	4.1	9.4								1650	29.0	2.77	19.9	86.3	3.07	2.5
30	7.0	0.5	1.1	1280	49.1	33.2	1.54	54.2	31.8	0.6	1430	31.7	2.87	22.5	90.5	3.24	2.7
	7.0	0.5	1.1	1500	49.7	35.0	1.56	55.0	31.8	0.6	1650	32.0	2.78	22.9	88.0	3.37	2.7
	10.5	1.9	4.4	1280	50.1	33.6	1.50	55.1	33.4	0.6	1430	32.7	2.87	23.4	91.2	3.34	2.8
	10.5	1.9	4.4	1500	50.8	35.3	1.52	55.9	33.4	0.6	1650	33.0	2.79	23.9	88.5	3.47	2.8
	14.0	3.9	9.0	1280	51.6	34.4	1.48	56.6	34.7	0.5	1430	33.2	2.87	24.0	91.5	3.39	2.9
	14.0	3.9	9.0	1500	52.3	36.2	1.51	57.4	34.7	0.5	1650	33.6	2.79	24.4	88.8	3.53	2.9
40	7.0	0.4	0.9	1280	51.9	35.8	1.68	57.6	30.9	1.1	1430	36.1	2.89	26.8	93.4	3.67	2.9
	7.0	0.4	0.9	1500	52.7	37.6	1.71	58.4	30.9	1.1	1650	36.5	2.80	27.4	90.5	3.82	3.0
	10.5	1.8	4.3	1280	52.3	35.8	1.60	57.7	32.7	1.0	1430	37.4	2.89	28.1	94.2	3.79	3.0
	10.5	1.8	4.3	1500	53.1	37.7	1.63	58.5	32.7	1.0	1650	37.8	2.81	28.6	91.2	3.95	3.1
	14.0	3.7	8.6	1280	52.7	35.9	1.57	57.9	33.6	0.9	1430	38.1	2.90	28.8	94.7	3.86	3.1
	14.0	3.7	8.6	1500	53.4	37.7	1.59	58.8	33.6	0.9	1650	38.5	2.81	29.3	91.6	4.02	3.2
50	7.0	0.3	0.7	1280	52.0	36.5	1.88	58.4	27.7	1.7	1430	40.9	2.91	31.5	96.5	4.11	3.1
	7.0	0.3	0.7	1500	52.8	38.4	1.91	59.2	27.7	1.8	1650	41.3	2.83	32.1	93.2	4.28	3.1
	10.5	1.8	4.1	1280	52.6	36.5	1.76	58.5	29.8	1.6	1430	42.4	2.92	33.0	97.5	4.26	3.2
	10.5	1.8	4.1	1500	53.3	38.4	1.79	59.3	29.8	1.6	1650	42.9	2.83	33.6	94.1	4.43	3.3
	14.0	3.6	8.2	1280	52.7	36.5	1.71	58.5	30.8	1.4	1430	43.2	2.92	33.8	98.0	4.33	3.3
	14.0	3.6	8.2	1500	53.5	38.4	1.74	59.4	30.8	1.4	1650	43.7	2.84	34.4	94.5	4.51	3.4
60	7.0	0.3	0.6	1280	50.2	35.8	2.12	57.3	23.7	3.8	1430	45.7	2.94	36.2	99.6	4.55	3.4
	7.0	0.3	0.6	1500	50.9	37.6	2.15	58.2	23.7	3.8	1650	46.2	2.86	36.9	95.9	4.74	3.5
	10.5	1.7	4.0	1280	51.3	36.2	1.98	58.0	25.9	3.4	1430	47.5	2.96	37.9	100.8	4.71	3.6
	10.5	1.7	4.0	1500	52.0	38.1	2.01	58.8	25.9	3.4	1650	48.0	2.87	38.7	97.0	4.91	3.6
	14.0	3.4	7.8	1280	51.8	36.4	1.91	58.3	27.1	3.0	1430	48.5	2.96	38.9	101.4	4.79	3.7
	14.0	3.4	7.8	1500	52.5	38.3	1.94	59.1	27.1	3.0	1650	49.0	2.88	39.6	97.5	4.99	3.8
70	7.0	0.2	0.5	1280	47.5	34.5	2.41	55.7	19.8	3.3	1430	50.6	2.98	40.9	102.8	4.97	3.8
	7.0	0.2	0.5	1500	48.2	36.3	2.44	56.5	19.8	3.4	1650	51.2	2.90	41.7	98.7	5.18	3.8
	10.5	1.7	3.9	1280	49.1	35.2	2.24	56.7	21.9	3.0	1430	52.6	3.01	42.9	104.1	5.13	3.9
	10.5	1.7	3.9	1500	49.7	37.1	2.28	57.5	21.9	3.0	1650	53.2	2.92	43.7	99.9	5.35	4.0
	14.0	3.3	7.5	1280	49.8	35.6	2.17	57.1	23.0	2.6	1430	53.7	3.02	43.9	104.8	5.22	4.1
	14.0	3.3	7.5	1500	50.5	37.4	2.20	57.9	23.0	2.7	1650	54.3	2.93	44.8	100.5	5.43	4.1
80	7.0	0.2	0.4	1280	44.5	33.0	2.74	53.8	16.2	4.3	1430	55.4	3.04	45.6	105.9	5.35	4.1
	7.0	0.2	0.4	1500	45.1	34.7	2.78	54.5	16.2	4.4	1650	56.1	2.95	46.5	101.5	5.57	4.1
	10.5	1.6	3.8	1280	46.1	33.8	2.56	54.8	18.0	4.0	1430	57.6	3.07	47.7	107.3	5.50	4.2
	10.5	1.6	3.8	1500	46.8	35.6	2.59	55.6	18.0	4.1	1650	58.3	2.98	48.6	102.7	5.73	4.3
	14.0	3.1	7.2	1280	46.9	34.2	2.47	55.3	19.0	3.7	1430	58.8	3.09	48.8	108.1	5.58	4.4
	14.0	3.1	7.2	1500	47.6	36.0	2.51	56.1	19.0	3.7	1650	59.5	3.00	49.7	103.4	5.81	4.4
85	7.0	0.2	0.4	1280	42.8	32.3	2.93	52.8	14.6	5.2	1430	57.8	3.08	47.8	107.4	5.51	4.2
	7.0	0.2	0.4	1500	43.5	34.0	2.97	53.6	14.6	5.3	1650	58.4	2.99	48.7	102.8	5.73	4.3
	10.5	1.6	3.7	1280	44.5	33.1	2.74	53.8	16.2	4.8	1430	60.0	3.11	49.9	108.9	5.65	4.4
	10.5	1.6	3.7	1500	45.1	34.8	2.78	54.6	16.2	4.9	1650	60.7	3.02	50.9	104.1	5.88	4.4
	14.0	3.0	7.0	1280	45.3	33.5	2.65	54.3	17.1	4.4	1430	61.2	3.14	51.0	109.6	5.72	4.5
	14.0	3.0	7.0	1500	46.0	35.2	2.68	55.1	17.1	4.5	1650	61.9	3.04	52.0	104.7	5.96	4.6
90	7.0	0.1	0.3	1280	41.2	31.6	3.12	51.8	13.2	5.9	1430	60.1	3.11	50.0	108.9	5.66	4.3
	7.0	0.1	0.3	1500	41.8	33.2	3.16	52.6	13.2	6.0	1650	60.8	3.02	51.0	104.1	5.90	4.4
	10.5	1.5	3.6	1280	42.9	32.3	2.92	52.8	14.7	5.4	1430	62.4	3.16	52.1	110.4	5.80	4.5
	10.5	1.5	3.6	1500	43.5	34.0	2.96	53.6	14.7	5.5	1650	63.1	3.06	53.2	105.4	6.04	4.6
	14.0	3.0	6.8	1280	43.7	32.7	2.82	53.3	15.5	5.0	1430	63.6	3.18	53.2	111.2	5.86	4.7
	14.0	3.0	6.8	1500	44.3	34.4	2.86	54.1	15.5	5.1	1650	64.3	3.09	54.3	106.1	6.10	4.8
100	7.0	0.1	0.2	1280	38.1	30.3	3.54	50.2	10.8	6.9	Operation not recommended						
	7.0	0.1	0.2	1500	38.7	31.9	3.59	50.9	10.8	7.1							
	10.5	1.5	3.5	1280	39.6	30.9	3.33	51.0	11.9	6.7							
	10.5	1.5	3.5	1500	40.2	32.5	3.38	51.7	11.9	6.8							
	14.0	2.8	6.5	1280	40.4	31.2	3.22	51.4	12.5	6.4							
	14.0	2.8	6.5	1500	41.0	32.8	3.27	52.1	12.5	6.6							
110	7.0	0.1	0.2	1280	35.5	29.6	4.02	49.3	8.8	8.9	Operation not recommended						
	7.0	0.1	0.2	1500	36.0	31.1	4.08	49.9	8.8	9.1							
	10.5	1.5	3.3	1280	36.7	29.8	3.79	49.6	9.7	8.6							
	10.5	1.5	3.3	1500	37.2	31.4	3.84	50.3	9.7	8.8							
	14.0	2.7	6.2	1280	37.3	30.0	3.67	49.9	10.2	8.3							
	14.0	2.7	6.2	1500	37.9	31.6	3.73	50.6	10.2	8.4							
120	7.0	0.1	0.1	1280	33.7	29.2	4.57	49.3	7.4	11.3	Operation not recommended						
	7.0	0.1	0.1	1500	34.2	30.7	4.63	50.0	7.4	11.5							
	10.5	1.4	3.2	1280	34.4	29.3	4.30	49.1	8.0	10.9							
	10.5	1.4	3.2	1500	34.9	30.8	4.36	49.8	8.0	11.1							
	14.0	2.6	6.0	1280	34.9	29.5	4.18	49.1	8.3	10.5							
	14.0	2.6	6.0	1500	35.4	31.0	4.24	49.8	8.3	10.7							

Interpolation is permissible; extrapolation is not.
 All entering air conditions are 80°F DB and 67°F WB in cooling, and 70°F DB in heating.
 AHRI/ISO certified conditions are 80.6°F DB and 66.2°F WB in cooling and 68°F DB in heating.
 Table does not reflect fan or pump power corrections for AHRI/ISO conditions.
 All performance is based upon the lower voltage of dual voltage rated units.
 Operation below 40°F EWT is based upon a 15% methanol antifreeze solution.
 Operation below 60°F EWT requires optional insulated water/refrigerant circuit.
 See performance correction tables for operating conditions other than those listed above.
 For operation in the shaded areas, please see the Performance Data Selection Notes.

Performance Data — Tranquility27® Model 064 - Full Load

1825 CFM Nominal (Rated) Airflow Cooling, 2050 CFM Nominal (Rated) Airflow Heating

Performance capacities shown in thousands of Btu/h

EWT °F	GPM	WPD		Cooling - EAT 80/67°F							Heating - EAT 70°F						
		PSI	FT	Airflow CFM	TC	SC	kW	HR	EER	HW	Airflow CFM	HC	kW	HE	LAT	COP	HW
20	15.0	5.0	11.6	Operation not recommended							1750	41.0	3.87	28.3	91.7	3.10	2.9
	15.0	5.0	11.6								2050	41.8	3.71	29.2	88.9	3.30	2.9
30	7.5	0.6	1.5	1580	65.8	41.6	2.78	75.1	23.7	0.8	1750	44.6	3.96	31.5	93.6	3.29	3.5
	7.5	0.6	1.5	1825	67.3	45.6	2.90	77.2	23.2	0.8	2050	45.4	3.8	32.6	90.5	3.50	3.5
	11.3	2.3	5.3	1580	66.7	42.1	2.65	75.7	25.2	0.7	1750	46.4	4.01	33.1	94.6	3.39	3.6
	11.3	2.3	5.3	1825	68.3	46.2	2.77	77.8	24.7	0.8	2050	47.3	3.85	34.3	91.4	3.60	3.7
	15.0	4.8	11	1580	68.1	42.9	2.60	76.8	26.2	0.7	1750	47.4	4.04	34.0	95.1	3.44	3.8
	15.0	4.8	11	1825	69.7	47.1	2.71	78.9	25.7	0.7	2050	48.3	3.88	35.2	91.8	3.65	3.8
40	7.5	0.5	1.2	1580	67.5	43.1	3.00	77.6	22.5	1.6	1750	50.6	4.13	36.9	96.8	3.59	4.0
	7.5	0.5	1.2	1825	69.1	47.3	3.13	79.8	22.0	1.6	2050	51.5	3.96	38.1	93.3	3.82	4.1
	11.3	2.2	5.1	1580	68.4	43.4	2.85	78.0	24.0	1.4	1750	52.8	4.19	38.8	97.9	3.69	4.2
	11.3	2.2	5.1	1825	70.0	47.6	2.98	80.2	23.5	1.5	2050	53.8	4.02	40.2	94.3	3.92	4.3
	15.0	4.5	10.4	1580	68.7	43.5	2.78	78.0	24.7	1.3	1750	53.9	4.22	39.9	98.5	3.74	4.4
	15.0	4.5	10.4	1825	70.3	47.7	2.90	80.2	24.2	1.3	2050	55.0	4.05	41.3	94.8	3.98	4.4
50	7.5	0.4	1.0	1580	67.7	43.9	3.27	78.7	20.7	2.7	1750	56.7	4.30	42.4	100.0	3.86	4.6
	7.5	0.4	1.0	1825	69.3	48.1	3.41	80.9	20.3	2.7	2050	57.8	4.12	43.8	96.1	4.11	4.7
	11.3	2.1	4.9	1580	68.4	43.9	3.08	78.8	22.2	2.4	1750	59.3	4.37	44.7	101.4	3.97	4.8
	11.3	2.1	4.9	1825	70.1	48.1	3.21	81.0	21.8	2.4	2050	60.4	4.19	46.2	97.3	4.22	4.9
	15.0	4.3	9.9	1580	68.8	43.9	2.99	78.9	23.0	2.1	1750	60.7	4.41	45.9	102.1	4.03	5.0
	15.0	4.3	9.9	1825	70.4	48.2	3.13	81.1	22.5	2.2	2050	61.8	4.23	47.5	97.9	4.28	5.1
60	7.5	0.4	0.8	1580	65.8	43.4	3.56	77.9	18.5	3.8	1750	63.0	4.48	48.0	103.3	4.12	5.3
	7.5	0.4	0.8	1825	67.3	47.6	3.72	80.0	18.1	3.8	2050	64.2	4.30	49.6	99.0	4.38	5.3
	11.3	2.1	4.8	1580	67.2	43.8	3.35	78.6	20.1	3.4	1750	66.0	4.57	50.6	104.9	4.23	5.5
	11.3	2.1	4.8	1825	68.8	48.0	3.49	80.7	19.7	3.4	2050	67.3	4.38	52.4	100.4	4.50	5.6
	15.0	4.1	9.4	1580	67.8	43.9	3.25	78.8	20.9	3.0	1750	67.6	4.62	52.1	105.8	4.29	5.7
	15.0	4.1	9.4	1825	69.4	48.1	3.39	80.9	20.5	3.0	2050	68.9	4.43	53.9	101.1	4.57	5.8
70	7.5	0.3	0.7	1580	63.1	42.5	3.91	76.4	16.1	5.1	1750	69.4	4.67	53.7	106.7	4.36	5.9
	7.5	0.3	0.7	1825	64.6	46.7	4.08	78.5	15.8	5.2	2050	70.8	4.48	55.6	102.0	4.63	6.0
	11.3	2.0	4.6	1580	65.0	43.2	3.66	77.5	17.8	4.6	1750	72.9	4.78	56.8	108.6	4.48	6.1
	11.3	2.0	4.6	1825	66.6	47.3	3.82	79.6	17.4	4.7	2050	74.4	4.58	58.8	103.6	4.76	6.2
	15.0	3.9	8.9	1580	65.9	43.4	3.54	77.9	18.6	4.0	1750	74.9	4.83	58.6	109.6	4.54	6.4
	15.0	3.9	8.9	1825	67.5	47.6	3.70	80.1	18.2	4.1	2050	76.3	4.63	60.6	104.5	4.83	6.5
80	7.5	0.2	0.5	1580	59.8	41.4	4.31	74.5	13.9	6.2	1750	76.1	4.87	59.7	110.3	4.58	6.5
	7.5	0.2	0.5	1825	61.2	45.4	4.50	76.6	13.6	6.3	2050	77.6	4.67	61.7	105.1	4.87	6.6
	11.3	2.0	4.5	1580	62.1	42.2	4.03	75.8	15.4	5.7	1750	80.2	5.00	63.3	112.4	4.70	6.7
	11.3	2.0	4.5	1825	63.6	46.3	4.21	77.9	15.1	5.8	2050	81.8	4.79	65.4	106.9	5.00	6.8
	15.0	3.7	8.4	1580	63.2	42.6	3.90	76.4	16.2	5.2	1750	82.5	5.07	65.3	113.6	4.77	7.0
	15.0	3.7	8.4	1825	64.7	46.7	4.07	78.6	15.9	5.3	2050	84.1	4.86	67.5	108.0	5.07	7.1
85	7.5	0.2	0.5	1580	58.0	40.7	4.54	73.6	12.8	7.0	1750	79.6	4.98	62.8	112.1	4.69	6.7
	7.5	0.2	0.5	1825	59.4	44.7	4.74	75.6	12.5	7.1	2050	81.2	4.78	64.9	106.7	4.98	6.8
	11.3	1.9	4.4	1580	60.4	41.6	4.24	74.9	14.2	6.4	1750	84.0	5.12	66.6	114.5	4.81	7.0
	11.3	1.9	4.4	1825	61.8	45.6	4.43	76.9	14.0	6.6	2050	85.6	4.91	68.9	108.7	5.11	7.1
	15.0	3.6	8.2	1580	61.5	42.0	4.10	75.5	15.0	5.9	1750	86.5	5.20	68.8	115.8	4.88	7.3
	15.0	3.6	8.2	1825	63.0	46.1	4.28	77.6	14.7	6.0	2050	88.1	4.98	71.2	109.8	5.19	7.4
90	7.5	0.2	0.4	1580	56.2	40.1	4.78	72.6	11.8	8.0	1750	83.1	5.09	65.9	114.0	4.79	7.0
	7.5	0.2	0.4	1825	57.5	43.9	4.99	74.6	11.5	8.1	2050	84.7	4.88	68.1	108.3	5.09	7.1
	11.3	1.9	4.3	1580	58.7	41.0	4.46	73.9	13.2	7.4	1750	87.8	5.24	70.0	116.5	4.91	7.3
	11.3	1.9	4.3	1825	60.0	44.9	4.65	75.9	12.9	7.5	2050	89.5	5.02	72.4	110.4	5.22	7.4
	15.0	3.5	8.0	1580	59.9	41.4	4.31	74.6	13.9	6.7	1750	90.5	5.32	72.3	117.9	4.98	7.6
	15.0	3.5	8.0	1825	61.3	45.4	4.49	76.6	13.6	6.9	2050	92.2	5.10	74.8	111.7	5.30	7.7
100	7.5	0.1	0.3	1580	52.4	38.6	5.32	70.7	9.8	8.7	Operation not recommended						
	7.5	0.1	0.3	1825	53.6	42.3	5.55	72.6	9.7	8.9							
	11.3	1.8	4.2	1580	54.9	39.6	4.96	71.9	11.1	8.4							
	11.3	1.8	4.2	1825	56.2	43.4	5.18	73.9	10.9	8.6							
	15.0	3.3	7.6	1580	56.1	40.1	4.79	72.5	11.7	8.1							
	15.0	3.3	7.6	1825	57.5	43.9	5.00	74.6	11.5	8.3							
110	7.5	0.1	0.2	1580	48.6	37.1	5.95	69.0	8.2	10.5	Operation not recommended						
	7.5	0.1	0.2	1825	49.7	40.7	6.21	71.0	8.0	10.8							
	11.3	1.8	4.0	1580	51.0	38.1	5.54	70.0	9.2	10.2							
	11.3	1.8	4.0	1825	52.2	41.7	5.78	72.0	9.0	10.4							
	15.0	3.1	7.2	1580	52.2	38.6	5.34	70.6	9.8	9.8							
	15.0	3.1	7.2	1825	53.5	42.3	5.58	72.5	9.6	10.0							
120	7.5	0.1	0.1	1580	44.9	35.7	6.67	67.9	6.7	12.5	Operation not recommended						
	7.5	0.1	0.1	1825	46.0	39.2	6.97	69.8	6.6	12.8							
	11.3	1.7	3.9	1580	47.1	36.6	6.21	68.5	7.6	12.0							
	11.3	1.7	3.9	1825	48.3	40.1	6.48	70.5	7.4	12.3							
	15.0	2.9	6.8	1580	48.3	37.0	5.99	69.0	8.1	11.6							
	15.0	2.9	6.8	1825	49.5	40.6	6.25	70.9	7.9	11.8							

Interpolation is permissible; extrapolation is not.
 All entering air conditions are 80°F DB and 67°F WB in cooling, and 70°F DB in heating.
 AHRI/ISO certified conditions are 80.6°F DB and 66.2°F WB in cooling and 68°F DB in heating.
 Table does not reflect fan or pump power corrections for AHRI/ISO conditions.
 All performance is based upon the lower voltage of dual voltage rated units.
 Operation below 40°F EWT is based upon a 15% methanol antifreeze solution.
 Operation below 60°F EWT requires optional insulated water/refrigerant circuit.
 See performance correction tables for operating conditions other than those listed above.
 For operation in the shaded areas, please see the Performance Data Selection Notes.

Performance Data — Tranquility 27® Model 072 - Part Load

1500 CFM Nominal (Rated) Airflow Cooling, 1600 CFM Nominal (Rated) Airflow Heating

Performance capacities shown in thousands of Btu/h

EWT °F	GPM	WPD		Cooling - EAT 80/67°F							Heating - EAT 70°F						
		PSI	FT	Airflow CFM	TC	SC	kW	HR	EER	HW	Airflow CFM	HC	kW	HE	LAT	COP	HW
20	15	10.1	23.3	Operation not recommended							1400	32.5	3.69	20.4	91.5	2.58	3.2
	15	10.1	23.3	Operation not recommended							1600	33.0	3.57	20.9	89.1	2.70	3.2
30	7.5	1.7	3.9	1400	58.2	39.3	2.15	65.5	27.1	0.7	1400	36.3	3.75	24.0	94.0	2.84	3.5
	7.5	1.7	3.9	1500	58.7	40.7	2.19	66.2	26.8	0.8	1600	36.9	3.64	24.6	91.3	2.97	3.6
	11.25	3.9	9.0	1400	59.1	39.7	2.05	66.0	28.9	0.7	1400	37.7	3.77	25.2	94.9	2.93	3.7
	11.25	3.9	9.0	1500	59.6	41.2	2.08	66.7	28.4	0.7	1600	38.3	3.66	25.9	92.1	3.07	3.7
	15.0	6.9	15.9	1400	60.1	40.2	2.01	66.8	30.0	0.6	1400	38.4	3.78	25.9	95.4	2.98	3.8
	15.0	6.9	15.9	1500	60.5	41.7	2.04	67.5	29.4	0.7	1600	39.0	3.67	26.6	92.6	3.12	3.9
40	7.5	1.6	3.7	1400	60.2	40.2	2.34	68.1	25.7	1.4	1400	42.4	3.84	29.7	98.1	3.24	3.9
	7.5	1.6	3.7	1500	60.7	41.6	2.39	68.8	25.2	1.5	1600	43.1	3.73	30.5	94.9	3.39	3.9
	11.25	3.6	8.3	1400	60.9	40.6	2.22	68.4	27.4	1.3	1400	44.3	3.87	31.5	99.3	3.35	4.0
	11.25	3.6	8.3	1500	61.4	42.1	2.26	69.1	27.0	1.3	1600	45.0	3.75	32.3	96.0	3.52	4.1
	15.0	6.5	15.0	1400	61.5	40.9	2.16	68.8	28.5	1.2	1400	45.4	3.89	32.4	100.0	3.42	4.2
	15.0	6.5	15.0	1500	62.0	42.4	2.20	69.5	28.0	1.2	1600	46.1	3.77	33.3	96.7	3.58	4.2
50	7.5	1.5	3.5	1400	61.0	40.6	2.59	69.8	23.5	2.4	1400	49.1	3.94	35.9	102.5	3.65	4.1
	7.5	1.5	3.5	1500	61.5	42.1	2.64	70.5	23.1	2.5	1600	49.9	3.82	36.9	98.9	3.82	4.2
	11.25	3.4	7.9	1400	61.7	41.0	2.44	69.9	25.3	2.2	1400	51.5	3.98	38.2	104.1	3.80	4.3
	11.25	3.4	7.9	1500	62.2	42.5	2.48	70.6	24.9	2.2	1600	52.3	3.86	39.2	100.3	3.98	4.3
	15.0	6	13.9	1400	62.0	41.1	2.36	70.0	26.2	1.9	1400	52.9	4.00	39.5	105.0	3.88	4.4
	15.0	6	13.9	1500	62.5	42.6	2.41	70.7	25.8	2.0	1600	53.7	3.88	40.5	101.1	4.06	4.5
60	7.5	1.4	3.2	1400	58.8	39.6	2.88	68.6	20.4	5.5	1400	56.1	4.05	42.5	107.1	4.06	4.6
	7.5	1.4	3.2	1500	59.3	41.0	2.93	69.3	20.1	5.6	1600	56.9	3.92	43.6	103.0	4.25	4.6
	11.25	3.1	7.2	1400	60.3	40.3	2.70	69.4	22.4	4.9	1400	59.0	4.09	45.2	109.0	4.22	4.7
	11.25	3.1	7.2	1500	60.7	41.7	2.75	70.1	22.0	5.0	1600	59.9	3.97	46.4	104.7	4.43	4.8
	15.0	5.4	12.5	1400	60.9	40.6	2.61	69.7	23.3	4.3	1400	60.6	4.12	46.7	110.1	4.31	4.9
	15.0	5.4	12.5	1500	61.3	42.0	2.66	70.4	22.9	4.4	1600	61.6	3.99	48.0	105.6	4.52	5.0
70	7.5	1.3	3.0	1400	55.9	38.2	3.21	66.9	17.4	4.8	1400	63.1	4.16	49.0	111.8	4.45	5.0
	7.5	1.3	3.0	1500	56.4	39.6	3.27	67.5	17.1	4.9	1600	64.1	4.03	50.3	107.1	4.66	5.1
	11.25	3	6.9	1400	57.8	39.0	3.00	68.0	19.2	4.3	1400	66.5	4.22	52.1	114.0	4.62	5.2
	11.25	3	6.9	1500	58.2	40.5	3.06	68.7	18.9	4.4	1600	67.5	4.09	53.5	109.1	4.84	5.3
	15.0	5.4	12.5	1400	58.6	39.4	2.90	68.5	20.2	3.8	1400	68.3	4.25	53.8	115.2	4.71	5.4
	15.0	5.4	12.5	1500	59.1	40.9	2.96	69.2	19.8	3.9	1600	69.3	4.12	55.3	110.1	4.94	5.5
80	7.5	1.3	3.0	1400	52.5	36.8	3.59	64.8	14.7	6.3	1400	70.0	4.28	55.4	116.3	4.80	5.4
	7.5	1.3	3.0	1500	53.0	38.1	3.65	65.5	14.4	6.4	1600	71.1	4.15	56.9	111.1	5.02	5.5
	11.25	2.8	6.5	1400	54.6	37.6	3.36	66.0	16.3	5.8	1400	73.6	4.35	58.7	118.7	4.96	5.6
	11.25	2.8	6.5	1500	55.0	39.0	3.42	66.7	16.0	5.9	1600	74.7	4.21	60.3	113.2	5.20	5.7
	15.0	5	11.6	1400	55.6	38.1	3.25	66.6	17.1	5.3	1400	75.5	4.38	60.5	119.9	5.05	5.8
	15.0	5	11.6	1500	56.0	39.4	3.31	67.3	16.8	5.4	1600	76.6	4.25	62.1	114.4	5.29	5.9
85	7.5	1.3	3.0	1400	50.8	36.1	3.80	63.8	13.4	7.6	1400	73.3	4.34	58.4	118.5	4.95	5.6
	7.5	1.3	3.0	1500	51.2	37.4	3.87	64.4	13.2	7.7	1600	74.4	4.21	60.0	113.1	5.18	5.7
	11.25	2.8	6.5	1400	52.8	36.9	3.56	65.0	14.9	7.0	1400	76.9	4.42	61.7	120.8	5.10	5.8
	11.25	2.8	6.5	1500	53.2	38.2	3.63	65.6	14.6	7.1	1600	78.0	4.28	63.4	115.2	5.34	5.9
	15.0	5	11.6	1400	53.8	37.3	3.44	65.6	15.7	6.4	1400	78.7	4.46	63.4	122.0	5.17	6.0
	15.0	5	11.6	1500	54.2	38.7	3.51	66.2	15.4	6.5	1600	79.9	4.32	65.1	116.2	5.42	6.1
90	7.5	1.3	3.0	1400	49.0	35.4	4.02	62.7	12.2	8.6	1400	76.5	4.41	61.4	120.6	5.09	5.8
	7.5	1.3	3.0	1500	49.4	36.6	4.09	63.3	12.0	8.8	1600	77.7	4.27	63.1	115.0	5.33	5.9
	11.25	2.8	6.5	1400	51.0	36.1	3.76	63.9	13.5	8.0	1400	80.1	4.49	64.7	123.0	5.23	6.0
	11.25	2.8	6.5	1500	51.4	37.5	3.83	64.5	13.3	8.1	1600	81.3	4.35	66.4	117.1	5.48	6.1
	15.0	5	11.6	1400	52.1	36.6	3.64	64.5	14.3	7.3	1400	81.9	4.53	66.3	124.2	5.30	6.2
	15.0	5	11.6	1500	52.5	37.9	3.71	65.2	14.0	7.5	1600	83.1	4.39	68.1	118.1	5.55	6.3
100	7.5	1.2	2.8	1400	45.4	34.1	4.51	60.9	10.1	10.2	Operation not recommended						
	7.5	1.2	2.8	1500	45.8	35.4	4.59	61.5	9.9	10.4							
	11.25	2.7	6.2	1400	47.3	34.8	4.23	61.8	11.2	9.8							
	11.25	2.7	6.2	1500	47.7	36.0	4.31	62.5	11.0	10.0							
	15.0	4.8	11.1	1400	48.4	35.1	4.09	62.4	11.8	9.4							
	15.0	4.8	11.1	1500	48.7	36.4	4.17	63.0	11.6	9.6							
110	7.5	1.1	2.5	1400	42.2	33.3	5.06	59.6	8.3	13.2	Operation not recommended						
	7.5	1.1	2.5	1500	42.6	34.5	5.15	60.2	8.2	13.5							
	11.25	2.5	5.8	1400	43.9	33.7	4.75	60.2	9.2	12.7							
	11.25	2.5	5.8	1500	44.2	34.9	4.84	60.8	9.1	13.0							
	15.0	4.5	10.4	1400	44.8	34.0	4.61	60.6	9.7	12.2							
	15.0	4.5	10.4	1500	45.1	35.2	4.69	61.2	9.6	12.5							
120	7.5	1.1	2.5	1400	39.6	33.1	5.70	59.2	7.0	16.7	Operation not recommended						
	7.5	1.1	2.5	1500	40.0	34.3	5.80	59.8	6.8	17.1							
	11.25	2.4	5.5	1400	40.9	33.1	5.35	59.3	7.6	16.1							
	11.25	2.4	5.5	1500	41.2	34.3	5.45	59.9	7.5	16.5							
	15.0	4.3	9.9	1400	41.6	33.2	5.19	59.4	8.0	15.5							
	15.0	4.3	9.9	1500	42.0	34.4	5.28	60.0	7.9	15.8							

Interpolation is permissible; extrapolation is not.
 All entering air conditions are 80°F DB and 67°F WB in cooling, and 70°F DB in heating.
 AHRI/ISO certified conditions are 80.6°F DB and 66.2°F WB in cooling and 68°F DB in heating.
 Table does not reflect fan or pump power corrections for AHRI/ISO conditions.
 All performance is based upon the lower voltage of dual voltage rated units.
 Operation below 40°F EWT is based upon a 15% methanol antifreeze solution.
 Operation below 60°F EWT requires optional insulated water/refrigerant circuit.
 See performance correction tables for operating conditions other than those listed above.
 For operation in the shaded areas, please see the Performance Data Selection Notes.

Performance Data — Tranquility27® Model 072 - Full Load

1950 CFM Nominal (Rated) Airflow Cooling, 2100 CFM Nominal (Rated) Airflow Heating

Performance capacities shown in thousands of Btu/h

EWT °F	GPM	WPD		Cooling - EAT 80/67°F							Heating - EAT 70°F						
		PSI	FT	Airflow CFM	TC	SC	kW	HR	EER	HW	Airflow CFM	HC	kW	HE	LAT	COP	HW
20	17.0	10.1	23.3	Operation not recommended							1850	44.6	4.82	28.8	92.3	2.7	3.8
	17.0	10.1	23.3								2100	45.3	4.67	29.6	90.0	2.8	3.8
30	8.5	2.2	5.1	1830	74.3	47.4	3.2	85.2	23.2	1.0	1850	49.0	4.89	32.8	94.5	2.9	4.6
	8.5	2.2	5.1	1950	74.9	49.2	3.3	86.0	23.0	1.1	2100	49.7	4.74	33.7	91.9	3.1	4.7
	12.8	5.0	11.6	1830	74.8	47.9	3.1	85.2	24.3	1.0	1850	51.1	4.94	34.8	95.6	3.0	4.8
	12.8	5.0	11.6	1950	75.4	49.6	3.1	86.1	24.1	1.0	2100	51.9	4.78	35.7	92.9	3.2	4.9
	17.0	8.9	20.6	1830	75.4	48.3	3.0	85.4	25.5	0.9	1850	52.3	4.96	35.8	96.2	3.1	5.0
	17.0	8.9	20.6	1950	76.0	50.0	3.0	86.3	25.3	0.9	2100	53.1	4.81	36.8	93.4	3.2	5.1
40	8.5	2.1	4.9	1830	78.6	49.6	3.4	90.1	23.1	2.2	1850	56.8	5.06	40.0	98.4	3.3	5.4
	8.5	2.1	4.9	1950	79.2	51.4	3.5	91.0	22.9	2.3	2100	57.7	4.90	41.1	95.4	3.4	5.5
	12.8	4.7	10.9	1830	79.1	50.0	3.3	90.2	24.0	2.0	1850	59.7	5.13	42.7	99.9	3.4	5.6
	12.8	4.7	10.9	1950	79.7	51.8	3.4	91.1	23.8	2.0	2100	60.6	4.97	43.8	96.7	3.6	5.7
	17.0	8.3	19.2	1830	79.6	50.3	3.2	90.3	25.1	1.8	1850	61.4	5.17	44.2	100.7	3.5	5.8
	17.0	8.3	19.2	1950	80.2	52.2	3.2	91.2	24.8	1.8	2100	62.3	5.01	45.3	97.5	3.6	5.9
50	8.5	1.9	4.4	1830	79.5	49.9	3.9	92.7	20.4	3.8	1850	65.5	5.27	47.9	102.8	3.6	6.2
	8.5	1.9	4.4	1950	80.1	51.7	4.0	93.7	20.2	3.9	2100	66.5	5.11	49.1	99.3	3.8	6.3
	12.8	4.3	9.9	1830	80.1	50.6	3.7	92.9	21.4	3.4	1850	69.3	5.37	51.3	104.7	3.8	6.4
	12.8	4.3	9.9	1950	80.8	52.5	3.8	93.8	21.2	3.5	2100	70.3	5.21	52.7	101.0	4.0	6.5
	17.0	7.7	17.8	1830	80.7	51.1	3.6	92.9	22.3	3.0	1850	71.4	5.43	53.2	105.7	3.9	6.7
	17.0	7.7	17.8	1950	81.3	53.0	3.7	93.9	22.1	3.1	2100	72.5	5.26	54.6	102.0	4.0	6.8
60	8.5	1.7	3.9	1830	77.4	49.0	4.4	92.5	17.5	5.5	1850	74.7	5.52	56.1	107.4	4.0	7.0
	8.5	1.7	3.9	1950	78.0	50.8	4.5	93.4	17.3	5.6	2100	75.8	5.35	57.6	103.4	4.2	7.1
	12.8	3.9	9.0	1830	78.2	49.6	4.2	92.7	18.5	4.9	1850	79.2	5.66	60.2	109.7	4.1	7.3
	12.8	3.9	9.0	1950	78.9	51.4	4.3	93.6	18.3	5.0	2100	80.5	5.49	61.8	105.5	4.3	7.4
	17.0	7.0	16.2	1830	79.1	50.0	4.2	93.2	19.0	4.3	1850	81.8	5.74	62.4	110.9	4.2	7.6
	17.0	7.0	16.2	1950	79.7	51.8	4.2	94.2	18.8	4.4	2100	83.0	5.56	64.1	106.6	4.4	7.7
70	8.5	1.7	3.9	1830	71.9	48.6	4.8	88.2	15.0	7.5	1850	84.0	5.81	64.4	112.0	4.2	7.9
	8.5	1.7	3.9	1950	72.5	50.3	4.9	89.1	14.9	7.7	2100	85.3	5.63	66.1	107.6	4.4	8.0
	12.8	3.9	9.0	1830	74.4	48.9	4.5	89.8	16.5	6.7	1850	89.2	5.99	68.9	114.6	4.4	8.2
	12.8	3.9	9.0	1950	75.0	50.7	4.6	90.8	16.3	6.8	2100	90.5	5.80	70.7	109.9	4.6	8.3
	17.0	6.9	15.9	1830	75.5	49.1	4.4	90.5	17.1	5.9	1850	92.0	6.09	71.3	116.0	4.4	8.5
	17.0	6.9	15.9	1950	76.1	50.8	4.5	91.4	16.9	6.0	2100	93.4	5.90	73.2	111.2	4.6	8.7
80	8.5	1.6	3.7	1830	67.5	48.0	5.2	85.4	13.0	9.1	1850	93.1	6.13	72.3	116.6	4.5	8.6
	8.5	1.6	3.7	1950	68.1	49.8	5.3	86.2	12.8	9.3	2100	94.5	5.94	74.3	111.7	4.7	8.8
	12.8	3.6	8.3	1830	70.6	48.4	4.9	87.4	14.4	8.4	1850	98.6	6.34	77.0	119.3	4.6	9.0
	12.8	3.6	8.3	1950	71.2	50.2	5.0	88.2	14.2	8.5	2100	100.1	6.15	79.1	114.1	4.8	9.1
	17.0	6.5	15.0	1830	72.0	48.6	4.8	88.3	15.1	7.7	1850	101.4	6.46	79.4	120.7	4.6	9.4
	17.0	6.5	15.0	1950	72.6	50.4	4.9	89.2	15.0	7.8	2100	102.9	6.26	81.5	115.4	4.8	9.5
85	8.5	1.6	3.7	1830	65.2	47.6	5.5	83.9	12.0	10.3	1850	97.4	6.30	76.0	118.7	4.5	9.0
	8.5	1.6	3.7	1950	65.7	49.3	5.6	84.8	11.9	10.5	2100	98.9	6.11	78.0	113.6	4.7	9.2
	12.8	3.6	8.3	1830	68.3	48.1	5.1	85.9	13.3	9.5	1850	102.7	6.53	80.5	121.4	4.6	9.4
	12.8	3.6	8.3	1950	68.8	49.8	5.2	86.7	13.2	9.7	2100	104.3	6.33	82.7	116.0	4.8	9.6
	17.0	6.5	15.0	1830	69.8	48.3	5.0	86.9	14.0	8.7	1850	105.4	6.67	82.8	122.8	4.6	9.8
	17.0	6.5	15.0	1950	70.4	50.1	5.1	87.7	13.9	8.9	2100	107.0	6.46	85.0	117.2	4.9	9.9
90	8.5	1.6	3.7	1830	62.9	47.1	5.7	82.5	11.0	11.8	1850	101.6	6.48	79.6	120.9	4.6	9.4
	8.5	1.6	3.7	1950	63.4	48.8	5.8	83.3	10.9	12.0	2100	103.2	6.27	81.8	115.5	4.8	9.6
	12.8	3.6	8.3	1830	66.0	47.8	5.4	84.4	12.3	10.9	1850	106.9	6.73	84.0	123.5	4.7	9.8
	12.8	3.6	8.3	1950	66.5	49.5	5.5	85.2	12.1	11.1	2100	108.5	6.52	86.3	117.9	4.9	10.0
	17.0	6.5	15.0	1830	67.6	48.0	5.2	85.4	13.0	9.9	1850	109.5	6.87	86.1	124.8	4.7	10.2
	17.0	6.5	15.0	1950	68.1	49.8	5.3	86.3	12.8	10.2	2100	111.1	6.65	88.4	119.0	4.9	10.4
100	8.5	1.5	3.5	1830	58.4	45.7	6.3	80.0	9.3	12.9	Operation not recommended						
	8.5	1.5	3.5	1950	58.8	47.3	6.4	80.8	9.2	13.2							
	12.8	3.4	7.9	1830	61.2	46.6	5.9	81.5	10.3	12.5							
	12.8	3.4	7.9	1950	61.7	48.3	6.0	82.3	10.2	12.7							
	17.0	6.1	14.1	1830	62.7	47.1	5.7	82.4	10.9	12.0							
	17.0	6.1	14.1	1950	63.2	48.8	5.8	83.2	10.8	12.2							
110	8.5	1.4	3.2	1830	54.7	43.8	6.9	78.5	7.9	15.6	Operation not recommended						
	8.5	1.4	3.2	1950	55.1	45.4	7.1	79.3	7.8	16.0							
	12.8	3.3	7.6	1830	56.8	45.0	6.5	79.3	8.7	15.0							
	12.8	3.3	7.6	1950	57.3	46.6	6.6	80.1	8.6	15.4							
	17.0	5.8	13.4	1830	58.1	45.6	6.3	79.9	9.2	14.5							
	17.0	5.8	13.4	1950	58.6	47.2	6.4	80.7	9.1	14.8							
120	8.5	1.4	3.2	1830	52.5	41.8	7.6	78.7	6.9	18.6	Operation not recommended						
	8.5	1.4	3.2	1950	52.9	43.3	7.8	79.5	6.8	19.0							
	12.8	3.1	7.2	1830	53.6	43.0	7.2	78.3	7.5	17.9							
	12.8	3.1	7.2	1950	54.0	44.6	7.3	79.1	7.4	18.2							
	17.0	5.6	12.9	1830	54.4	43.7	7.0	78.4	7.8	17.2							
	17.0	5.6	12.9	1950	54.9	45.2	7.1	79.2	7.7	17.6							

Interpolation is permissible; extrapolation is not.
 All entering air conditions are 80°F DB and 67°F WB in cooling, and 70°F DB in heating.
 AHRI/ISO certified conditions are 80.6°F DB and 66.2°F WB in cooling and 68°F DB in heating.
 Table does not reflect fan or pump power corrections for AHRI/ISO conditions.
 All performance is based upon the lower voltage of dual voltage rated units.
 Operation below 40°F EWT is based upon a 15% methanol antifreeze solution.
 Operation below 60°F EWT requires optional insulated water/refrigerant circuit.
 See performance correction tables for operating conditions other than those listed above.
 For operation in the shaded areas, please see the Performance Data Selection Notes.

Performance Data Selection Notes

For operation in the shaded area when water is used in lieu of an anti-freeze solution, the LWT (Leaving Water Temperature) must be calculated. Flow must be maintained to a level such that the LWT is maintained above 40°F [4.4°C] when the JW3 jumper is not clipped (see example below). This is due to the potential of the refrigerant temperature being as low as 32°F [0°C] with 40°F [4.4°C] LWT, which may lead to a nuisance cutout due to the activation of the Low Temperature Protection. JW3 should never be clipped for standard range equipment or systems without antifreeze.

Example:

At 50°F EWT (Entering Water Temperature) and 1.5 gpm/ton, a 3 ton unit has a HE of 22,500 Btuh. To calculate LWT, rearrange the formula for HE as follows:

$HE = TD \times GPM \times 500$, where HE = Heat of Extraction (Btuh);
 TD = temperature difference (EWT - LWT) and GPM = U.S. Gallons per Minute.

$$TD = HE / (GPM \times 500)$$

$$TD = 22,500 / (1.5 \times 500)$$

$$TD = 10^\circ F$$

$$LWT = EWT - TD$$

$$LWT = 50 - 10 = 40^\circ F$$

In this example, as long as the EWT does not fall below 50°F, the system will operate as designed. For EWTs below 50°F, higher flow rates will be required (open loop systems, for example, require at least 2 gpm/ton when EWT is below 50°F).

Performance capacities shown in thousands of Btuh

Heating - EAT 70°F							
HWC	Airflow CFM	HC	kW	HE	LAT	COP	HWC
	1850	44.6	4.82	28.8	92.3	2.7	4.9
	2100	45.3	4.67	29.6	90.0	2.8	5.0
2	1850	49.0	4.89	32.8	94.5	2.9	5.8
3	2100	49.7	4.74	33.7	91.9	3.1	5.9
4	1850	51.1	4.94	34.8	95.6	3.0	5.8
5	2100	51.9	4.78	35.7	92.9	3.2	5.9
6	1850	52.3	4.96	35.8	96.2	3.1	5.8
7	2100	53.1	4.81	36.8	93.4	3.2	5.9
8	1850	56.8	5.06	40.0	98.4	3.3	6.6
9	2100	57.7	4.90	41.1	95.4	3.4	6.7
10	1850	59.7	5.13	42.7	99.9	3.4	6.6
	2100	60.6	4.97	43.8	96.7	3.6	6.7
	1850	61.4	5.17	44.2	100.7	3.5	6.6
	2100	62.3	5.01	45.3	97.5	3.6	6.7
3.6	1850	65.5	5.27	47.9	102.8	3.6	7.4
3.7	2100	66.5	5.11	49.1	99.3	3.8	7.6
3	1850	69.3	5.37	51.3	104.7	3.8	7.7
	2100	70.3	5.21	52.7	101.0	4.0	7.8
	1850	71.4	5.43	53.2	105.7	3.9	7.9
	2100	72.5	5.26	54.6	102.0	4.1	8.0
	1850	74.7	5.52	56.1	107.4	4.1	8.1
	2100	75.8	5.35	57.6	103.7	4.3	8.2

Model	026	038	049	064	072
Compressor (1 Each)	Copeland UltraTech Two-Stage Scroll				
Factory Charge HFC-410a, oz [kg]	58 [1.64]	78 [2.21]	81 [2.30]	144 [4.08]	156 [4.42]
ECM Fan Motor & Blower Wheel					
Fan Motor Type & Speeds	ECM Variable Speed				
Fan Motor, hp [W]	1/2 [373]	1/2 [373]	1 [746]	1 [746]	1 [746]
Blower Wheel Size (Dia x W), in [mm]	9 x 7 [229 x 178]	11 x 10 [279 x 254]	11 x 10 [279 x 254]	11 x 10 [279 x 254]	11 x 10 [279 x 254]
Water Connection Size					
Swivel - Residential Class	1"	1"	1"	1"	1"
HWG Water Connection Size					
Swivel - Residential Class	1"	1"	1"	1"	1"
Vertical Upflow/Downflow					
Air Coil Dimensions (H x W), in [mm]	28 x 20 [711 x 542]	28 x 25 [711 x 635]	32 x 25 [813 x 635]	36 x 25 [914 x 635]	36 x 25 [914 x 635]
Standard Filter - 2" [51mm] Pleated MERV11 Throwaway, in [mm]	28 x 24 [712 x 610]	28 x 29.5 [712 x 749]	32 x 29.5 [813 x 749]	36 x 29.5 [914 x 749]	36 x 29.5 [914 x 749]
Weight - Operating, lbs [kg]	266 [120.7]	327 [148.6]	416 [189.1]	443 [201.4]	443 [201]
Weight - Packaged, lbs [kg]	276 [125.2]	337 [153.2]	426 [193.6]	453 [205.9]	453 [206]
Horizontal					
Air Coil Dimensions (H x W), in [mm]	18 x 31 [457 x 787]	20 x 35 [508 x 889]	20 x 40 [508 x 1018]	20 x 45 [508 x 1143]	20 x 45 [508 x 1143]
Standard Filter - 2" [51mm] Pleated MERV11 Throwaway, in [mm]	2 - 18 x 18 [457 x 457]	1 - 12 x 20 [305 x 508] 1 - 20 x 25 [508 x 635]	1 - 18 x 20 [457 x 508] 1 - 20 x 24 [508 x 610]	2 - 20 x 24 [508 x 610]	2 - 20 x 24 [508 x 610]
Weight - Operating, lbs [kg]	266 [120.7]	327 [148.6]	416 [189.1]	443 [201.4]	443 [201]
Weight - Packaged, lbs [kg]	276 [125.2]	337 [153.2]	426 [193.6]	453 [205.9]	453 [206]

All units have grommet compressor mountings, TXV expansion devices, and 1/2" [12.7mm] & 3/4" [19.1mm] electrical knockouts.

Dimensions — Vertical Upflow Tranquility 27®

Vertical Upflow Model		Overall Cabinet		
		A Width	B Depth	C Height
TT026	in	22.4	25.6	48.5
	cm	56.8	65.1	123.2
TT038	in	25.4	30.6	50.5
	cm	64.5	77.8	128.3
TT049	in	25.4	30.6	54.5
	cm	64.5	77.8	138.4
TT064	in	25.4	30.6	58.5
	cm	64.5	77.8	148.6
TT072	in	25.4	30.6	58.5
	cm	64.5	77.8	148.6

Vertical Upflow Model		Water Connections						
		1	2	3	4	5		
		D In	E Out	F HWG IN	G HWG Out	H Condensate	Loop Water FPT	HWG FPT
026	in	2.1	10.0	13.9	16.9	7.8	1"	1"
	cm	5.2	25.4	35.2	42.9	19.8	Swivel	Swivel
038	in	3.4	10.8	15.6	18.9	7.8	1"	1"
	cm	8.6	27.5	39.7	47.9	19.8	Swivel	Swivel
049	in	3.4	10.8	15.6	18.9	7.8	1"	1"
	cm	8.6	27.5	39.7	47.9	19.8	Swivel	Swivel
064	in	3.4	10.8	15.6	18.9	7.8	1"	1"
	cm	8.6	27.5	39.7	47.9	19.8	Swivel	Swivel
072	in	3.4	10.8	15.6	18.9	7.8	1"	1"
	cm	8.6	27.5	39.7	47.9	19.7	Swivel	Swivel

Vertical Upflow Model		Electrical Knockouts		
		J 1/2"	K 1/2"	L 3/4"
		Low Voltage	External Pump	Power Supply
026	in	3.6	6.1	8.6
	cm	9.2	15.6	21.9
038	in	3.6	6.1	8.6
	cm	9.2	15.6	21.9
049	in	3.6	6.1	8.6
	cm	9.2	15.6	21.9
064	in	3.6	6.1	8.6
	cm	9.2	15.6	21.9
072	in	3.6	6.1	8.6
	cm	9.2	15.6	21.9

Condensate is 3/4" PVC female glue socket and is switchable from front to side.
 Unit shipped with deluxe duct collar/filter rack extending from unit 3" [7.6cm] and is suitable for duct connection.
 Discharge flange is field installed.

Dimensions — Vertical Upflow Tranquility 27®

Vertical Upflow Model		Discharge Connection Duct Flange Installed (+/- 0.10 in, +/- 2.5mm)					Return Connection Standard Deluxe Filter Rack (+/- 0.10 in, +/- 2.5mm)			
		M Left Return	N	O Supply Width	P Supply Depth	Q Right Return	R	S Return Depth	T Return Height	U
026	in cm	7.8 18.3	5.8 14.8	14.0 35.6	14.0 35.6	4.9 12.4	1.7 4.2	22.2 56.4	26.2 66.4	1.5 3.9
038	in cm	6.4 16.1	6.3 16.0	18.0 45.7	18.0 45.7	5.3 13.5	2.1 5.4	27.1 68.9	26.1 66.4	1.5 3.9
049	in cm	6.4 16.1	6.3 16.0	18.0 45.7	18.0 45.7	5.3 13.5	2.1 5.4	27.1 68.9	30.1 76.5	1.5 3.9
064	in cm	6.4 16.1	6.3 16.0	18.0 45.7	18.0 45.7	5.3 13.5	2.1 5.4	27.1 68.9	34.1 86.7	1.5 3.9
072	in cm	6.4 16.1	6.3 16.0	18.0 45.7	18.0 45.7	5.3 13.5	2.1 5.4	27.1 68.9	34.1 86.7	1.5 3.9

Legend
 CAP=Control Access Panel
 CSP=Compressor Service Panel
 BSP=Blower Service Panel
 ASP=Alternate Service Panel

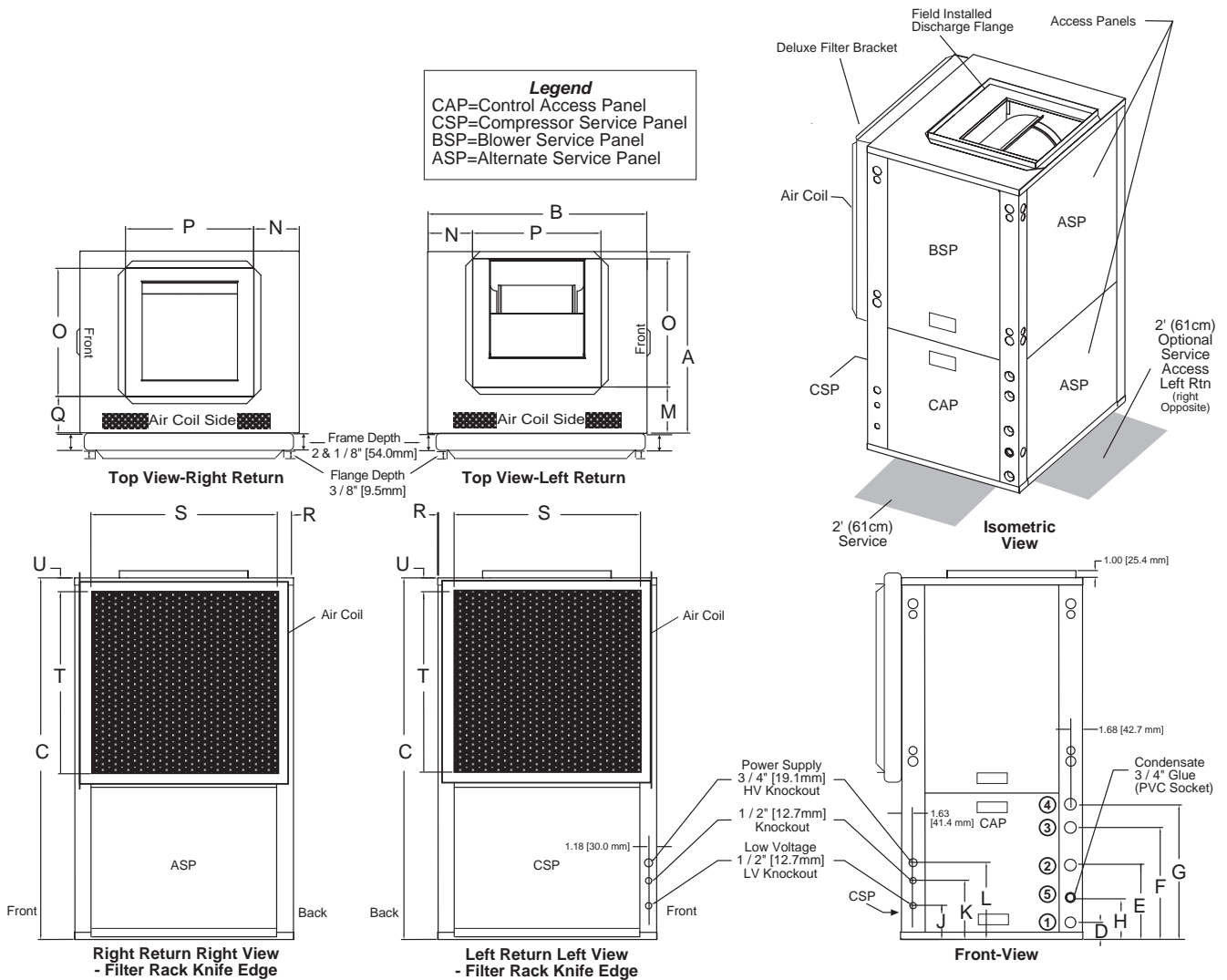

Dimensions — Vertical Downflow Tranquility 27[®]

Vertical Downflow Model		Overall Cabinet		
		A Width	B Depth	C Height
026	in	22.4	25.6	52.5
	cm	56.8	65.1	133.4
038	in	25.4	30.6	54.5
	cm	64.5	77.8	138.4
049	in	25.4	30.6	58.5
	cm	64.5	77.8	148.6
064	in	25.4	30.6	62.5
	cm	64.5	77.8	158.8
072	in	25.4	30.6	62.5
	cm	64.5	77.8	158.8

Vertical Downflow Model		Water Connections						
		1	2	3	4	5		
		D In	E Out	F HWG IN	G HWG Out	H Condensate	Loop Water FPT	HWG FPT
026	in	17.2	9.3	5.4	2.4	3.6	1"	1"
	cm	43.7	23.6	13.7	6.1	9.2	Swivel	Swivel
038	in	17.9	10.5	5.7	2.4	3.6	1"	1"
	cm	45.5	26.7	14.5	6.1	9.2	Swivel	Swivel
049	in	17.9	10.5	5.7	2.4	3.6	1"	1"
	cm	45.5	26.7	14.5	6.1	9.2	Swivel	Swivel
064	in	17.9	10.5	5.7	2.4	3.6	1"	1"
	cm	45.5	26.7	14.5	6.1	9.2	Swivel	Swivel
072	in	17.9	10.5	5.7	2.4	3.6	1"	1"
	cm	45.5	26.7	14.5	6.1	9.2	Swivel	Swivel

Vertical Downflow Model		Electrical Knockouts		
		J 1/2"	K 1/2"	L 3/4"
		Low Voltage	External Pump	Power Supply
026	in	15.7	13.2	10.7
	cm	39.9	33.5	27.2
038	in	17.7	15.2	12.7
	cm	45.0	38.6	32.3
049	in	17.7	15.2	12.7
	cm	45.0	38.6	32.3
064	in	17.7	15.2	12.7
	cm	45.0	38.6	32.3
072	in	17.7	15.2	12.7
	cm	45.0	38.6	32.3

Condensate is 3/4" PVC female glue socket and is switchable from front to side. Unit shipped with deluxe duct collar/filter rack extending from unit 3" [7.6cm] and is suitable for duct connection. Downflow unit does not have discharge flange, and is rated for zero clearance installation.

Dimensions — Vertical Downflow Tranquility 27®

Vertical Downflow Model		Discharge Connection Duct Flange Installed (+/- 0.10 in, +/- 2.5mm)					Return Connection Standard Deluxe Filter Rack (+/- 0.10 in, +/- 2.5mm)			
		M Left Return	N	O Supply Width	P Supply Depth	Q Right Return	R	S Return Depth	T Return Height	U
026	in cm	6.7 17.1	8.4 21.4	9.9 25.3	9.1 23.0	10.8 27.4	1.7 4.2	22.2 56.4	26.2 66.4	21.2 53.9
038	in cm	7.4 18.7	9.0 22.9	13.1 33.3	12.9 32.7	10.4 26.5	1.7 4.2	27.1 68.9	26.1 66.4	23.2 59.0
049	in cm	7.4 18.7	9.0 22.9	13.1 33.3	12.9 32.7	10.4 26.5	1.7 4.2	27.1 68.9	30.1 76.5	23.2 59.0
064	in cm	7.4 18.7	9.0 22.9	13.1 33.3	12.9 32.7	10.4 26.5	1.7 4.2	27.1 68.9	34.1 86.7	23.2 59.0
072	in cm	7.4 18.7	9.0 22.9	13.1 33.3	12.9 32.7	10.4 26.5	1.7 4.2	27.1 68.9	34.1 86.7	23.2 59.0



Dimensions — Horizontal Tranquility 27[®]

Horizontal Model		Overall Cabinet		
		A Width	B Depth	C Height
026	in	22.4	62.2	19.3
	cm	56.8	158.0	48.9
038	in	25.4	71.2	21.3
	cm	64.5	180.8	54.0
049	in	25.4	76.2	21.3
	cm	64.5	193.5	54.0
064	in	25.4	81.2	21.3
	cm	64.5	206.2	54.0
072	in	25.4	81.2	21.3
	cm	64.5	206.2	54.0

Horizontal Model		Water Connections						
		1	2	3	4	5		
		D In	E Out	F HWG IN	G HWG Out	H Condensate	Loop Water FPT	HWG FPT
026	in	2.1	10.0	13.9	16.9	0.6	1" Swivel	1" Swivel
	cm	5.2	25.4	35.2	42.9	1.5		
038	in	3.4	10.8	15.6	18.9	0.6	1" Swivel	1" Swivel
	cm	8.6	27.5	39.7	47.9	1.5		
049	in	3.4	10.8	15.6	18.9	0.6	1" Swivel	1" Swivel
	cm	8.6	27.5	39.7	47.9	1.5		
064	in	3.4	10.8	15.6	18.9	0.6	1" Swivel	1" Swivel
	cm	8.6	27.5	39.7	47.9	1.5		
072	in	3.4	10.8	15.6	18.9	0.6	1" Swivel	1" Swivel
	cm	8.6	27.5	39.7	47.9	1.5		

Horizontal Model		Electrical Knockouts		
		J 1/2"	K 1/2"	L 3/4"
		Low Voltage	External Pump	Power Supply
026	in	3.6	6.1	8.6
	cm	9.2	15.6	21.9
038	in	3.4	6.1	8.6
	cm	9.2	15.6	21.9
049	in	3.6	6.1	8.6
	cm	9.2	15.6	21.9
064	in	3.6	6.1	8.6
	cm	9.2	15.6	21.9
072	in	3.6	6.1	8.6
	cm	9.2	15.6	21.9

Condensate is 3/4" FPT.

Unit shipped with deluxe duct collar/filter rack extending from unit 3" [7.6cm] and is suitable for duct connection. Discharge flange and hanger brackets are factory installed.

Dimensions — Horizontal Tranquility 27®

Horizontal Model		1Discharge Connection Duct Flange Installed (+/- 0.10 in, +/- 2.5mm)						Return Connection Standard Deluxe Filter Rack (+/- 0.10 in, +/- 2.5mm)			
		M	N	O Supply Height	P Supply Width	Q	R	S Return Width	T Return Height	U	V
018	in cm	5.0 12.7	6.8 17.3	12.5 31.8	15.5 39.4	5.0 12.7	2.1 5.3	33.8 85.8	16.2 41.0	2.2 5.6	1.0 2.5
024 - 030	in cm	3.6 9.3	2.0 5.1	12.5 31.8	15.5 39.4	3.6 9.2	2.0 5.2	33.8 85.8	16.2 41.0	2.3 5.8	1.5 3.9
036	in cm	*3.1 7.9	1.2 3.1	19.0 48.3	17.5 44.5	*3.1 7.9	1.0 2.6	34.8 88.3	18.2 46.1	3.1 7.8	1.5 3.9
042 - 048	in cm	3.1 7.9	1.2 3.1	19.0 48.3	17.5 44.5	3.1 7.9	1.0 2.6	39.8 101.0	18.2 46.1	3.1 7.8	1.5 3.9
060 - 070	in cm	3.1 7.9	1.2 3.1	19.0 48.3	17.5 44.5	3.1 7.9	1.0 2.6	44.8 113.7	18.2 46.1	3.1 7.8	1.5 3.9

*For units with modulating reheat option this dimension is 2.9" (7.4 cm).

1Discharge connection will change when using the accessory auxiliary electric heat package. Refer to the heater IOM for details.

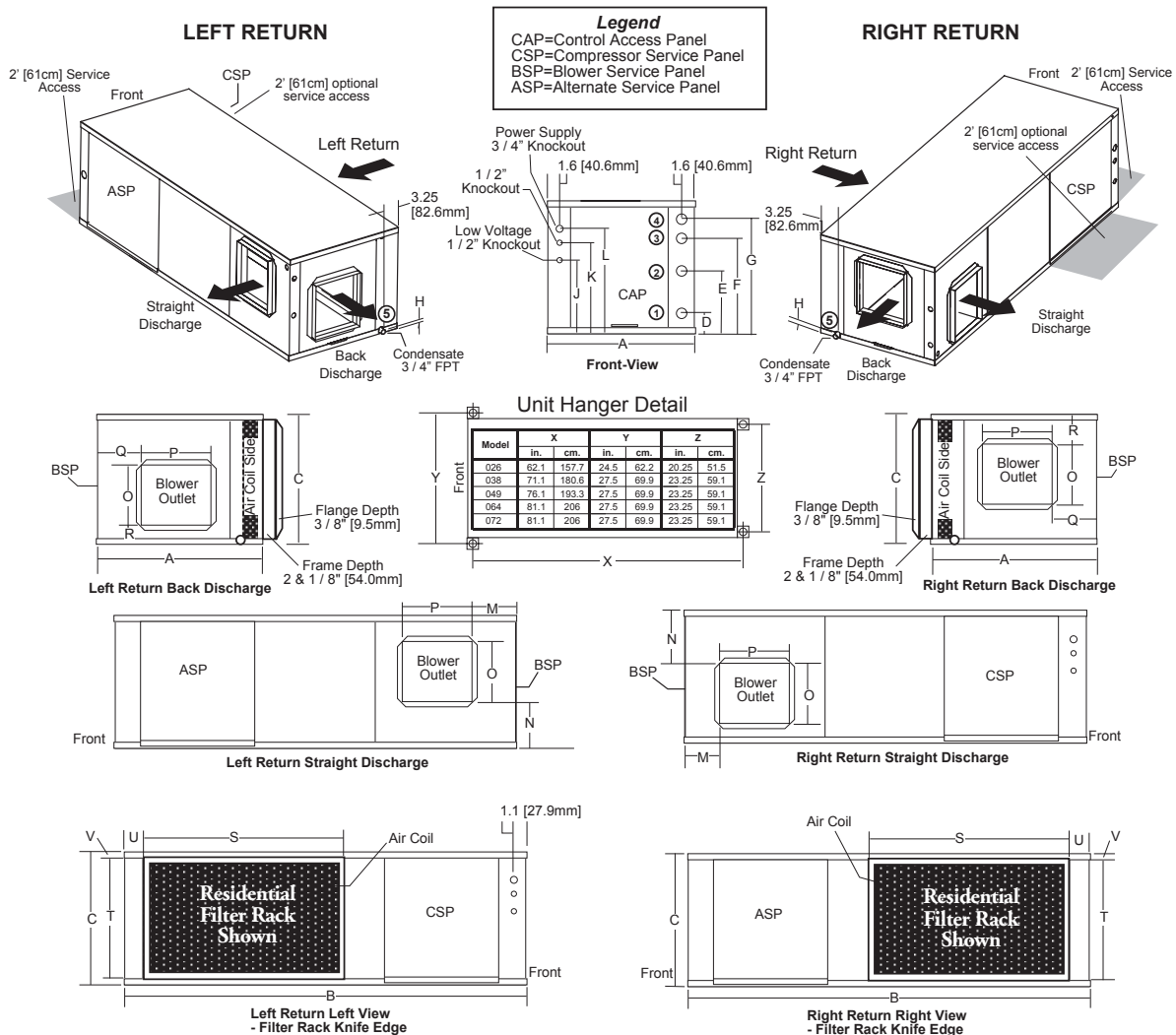

Rev.: 06/18/10B

Electrical Data

All TT Units with Emerson ECM Fan Motor							TT Units (ECM) Standard					TT Units (ECM) with ClimaDry					
Model	Compressor			HWG Pump FLA	Ext Loop Pump FLA	Fan Motor FLA	Total Unit FLA	Min Circuit Amps	Max Fuse/HACR (2)	Supply Wire (2)		ClimaDry Pump FLA	Total Unit FLA	Min Circuit Amps	Max/Fuse HACR (2)	Supply Wire (2)	
	RLA	LRA	Qty							Min AWG 60°C (1, 4)	Max Length Ft (m) (3)					Min AWG 60°C (1, 4)	Max Length Ft (m) (3)
	026	10.3	52.0							1	0.40					4.0	3.9
038	16.7	82.0	1	0.40	4.0	3.9	25.0	29.2	45	10	63 (19.1)	0.8	25.8	30.0	45	8	97 (29.6)
049	21.2	96.0	1	0.40	4.0	6.9	32.5	37.8	50	8	78 (23.8)	1.07	33.6	38.9	60	8	76 (23.1)
064	25.6	118.0	1	0.40	4.0	6.9	36.9	43.3	60	6	108 (32.9)	1.07	38.0	44.4	60	6	105 (32.1)
072	27.2	150.0	1	0.40	4.0	6.9	38.5	45.3	70	6	103 (31.4)	1.07	39.6	46.4	70	6	101 (30.8)

Rated Voltage of 208-230/60/1
HACR circuit breaker in USA only

Min/Max Voltage of 197/254
All fuses Class RK-5

Notes:

- (1) If wire is applied at ambient greater than 86°F (30°C), consult table 310-16 of the National Electrical Code (NEC). The ampacity of non-metallic sheathed cable (NM), otherwise known as Romex cable, shall be that of 60°C (140°F) conditions per the NEC Article 336-26. If other wiring is used, consult applicable tables of the NEC.
- (2) Current carrying capacity (amperes) of the wire used must not be less than the fuse/breaker size used.
- (3) Wire length based on one way measurement with 2% voltage drop.
- (4) Wire size based on 60°C copper conductor and Minimum Circuit Ampacity.

Tranquility 27® ECM Control Features

The ECM fan is controlled by an interface board that converts thermostat inputs and field selectable CFM settings to signals used by the ECM motor controller. Units manufactured before July 2005 have version I (P/N 69243707). Units manufactured between July 2005 and May 11, 2009 have version II (P/N 17B0019N01). Fan speeds are selected with jumpers for version I or via a nine position DIP switch for version II and III. To take full advantage of the ECM motor features, a multi-stage thermostat should be used (2-stage heat/2-stage cool or 3-stage heat/2-stage cool).

HFC-410A packaged units built after May 11, 2009 have ECM controller version III (P/N 17B0034N01). This controller includes logic and a relay to control the HWG functions.

Note: Power must be off to the unit for at least three seconds before the ECM motor will recognize a speed change. The motor will recognize a change in the CFM Adjust or dehumidification mode settings while the unit is powered.

There are four different airflow settings from lowest airflow rate (speed tap 1) to the highest airflow rate (speed tap 4). The charts below indicate settings for both versions of the ECM interface board, followed by detailed information for each setting.

Cooling Settings: The cooling setting determines the cooling (normal) CFM for all units with ECM motor. Cooling (normal) setting is used when the unit is not in dehumidification mode. This setting also determines the heating CFM for Genesis (GS) units. Tap 1 is the lowest CFM setting, while tap 4 is the highest CFM setting. To avoid air coil freeze-up, tap 1 may not be used if the dehumidification mode is selected. Consult submittal data or specifications catalog for the specific unit series and model to correlate speed tap setting to airflow in CFM.

Heating Settings: The heating setting determines the heating CFM for Tranquility 27® (TT) and Tranquility 20 (TS) units. This setting is not used for Genesis (GS) units. Tap 1 is the lowest CFM setting, while tap 4 is the highest CFM setting. Consult submittal data or specifications catalog for the specific unit series and model to correlate speed tap setting to airflow in CFM.

Auxiliary/Emergency Heat Settings: The auxiliary/emergency heat setting determines the CFM when the unit is in auxiliary heat or emergency heat mode. This setting is used for residential units with internal electric heat. When auxiliary electric heat is energized (i.e. compressor and electric heat), the greater of the auxiliary/emergency or heating setting will be used. A "G" (fan) signal must be present from the thermostat for electric heat to operate.

Consult the submittal data or specifications catalog for the specific unit series and model to correlate speed tap setting to airflow in CFM.

CFM Adjust Settings: The CFM adjust setting allows four selections. The NORM setting is the factory default position. The + or – settings adjust the airflow by +/- 15%. The +/- settings are used to "fine tune" airflow adjustments. The TEST setting runs the ECM motor at 70% torque, which causes the motor to operate like a standard PSC motor, and disables the CFM counter.

Dehumidification Mode Settings: The dehumidification mode setting provides field selection of humidity control. When operating in the normal mode, the cooling airflow settings are determined by the cooling tap setting above. When dehumidification is enabled there is a reduction in airflow in cooling to increase the moisture removal of the heat pump. Consult submittal data or specifications catalog for the specific unit series and model to correlate speed tap to airflow in CFM. The dehumidification mode can be enabled in two ways.

1. **Constant Dehumidification Mode:** When the dehumidification mode is selected (via DIP switch or jumper setting), the ECM motor will operate with a multiplier applied to the cooling CFM settings (approx. 20-25% lower airflow). Any time the unit is running in the cooling mode, it will operate at the lower airflow to improve latent capacity. The "DEHUM" LED will be illuminated at all times. Heating airflow is not affected. NOTE: Do not select dehumidification mode if cooling setting is tap 1.
2. **Automatic (Humidistat-controlled) Dehumidification Mode:** When the dehumidification mode is selected (via DIP switch or jumper setting) AND a humidistat is connected to terminal DH (version II) or HUM (version I), the cooling airflow will only be reduced when the humidistat senses that additional dehumidification is required. The DH (or HUM) terminal is reverse logic. Therefore, a humidistat (not dehumidistat) is required. The "DEHUM" LED will be illuminated only when the humidistat is calling for dehumidification mode. Heating airflow is not affected. NOTE: Do not select dehumidification mode if cooling setting is tap 1.

Tranquility 27[®] ECM Control Features

ECM Board Tap Settings

Cooling settings: TT, TS Units

Tap Setting	Version I 69243707	Version II and III (17B0019N01 & 17B0034N01)	
	HP CFM Jumper	DIP Switch	
		SW1	SW2
1	1	ON	ON
2	2	ON	OFF
3	3	OFF	ON
4	4	OFF	OFF

Heating settings: TT, TS Units

Tap Setting	Version I 69243707	Version II and III (17B0019N01 & 17B0034N01)	
	DELAY Jumper	DIP Switch	
		SW3	SW4
1	1	ON	ON
2	2	ON	OFF
3	3	OFF	ON
4	4	OFF	OFF

Aux/Emerg Heat settings: TT, TS Units

Tap Setting	Version I 69243707	Version II and III (17B0019N01 & 17B0034N01)	
	AUX CFM Jumper	DIP Switch	
		SW5	SW6
1	1	ON	ON
2	2	ON	OFF
3	3	OFF	ON
4	4	OFF	OFF

CFM Adjust settings: TT, TS Units

Tap Setting	Version I 69243707	Version II and III (17B0019N01 & 17B0034N01)	
	CFM Adj Jumper	DIP Switch	
		SW7	SW8
TEST	1	ON	ON
-	2	ON	OFF
+	3	OFF	ON
NORM	4	OFF	OFF

Dehum Mode settings: TT, TS Units

Tap Setting	Version I 69243707	Version II and III (17B0019N01 & 17B0034N01)
	Dehumid Jumper	DIP Switch
		SW9
NORM	pins 1,2	ON
Dehumid	pins 2,3	OFF

ECM Version II Interface Layout

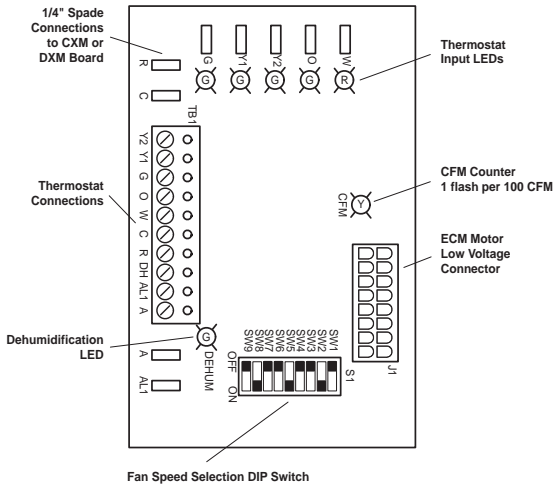

ECM Version I Interface Layout

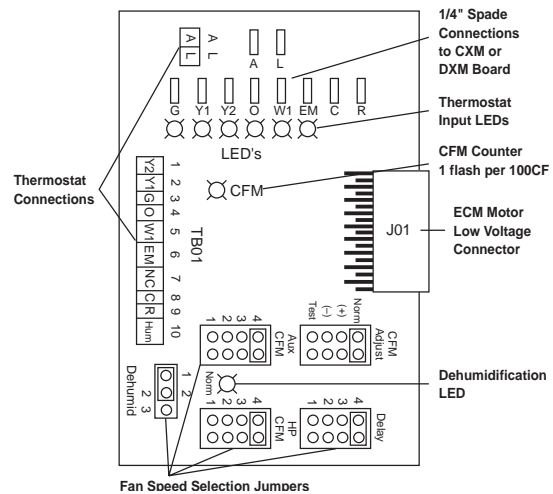

ECM Version III Interface Layout

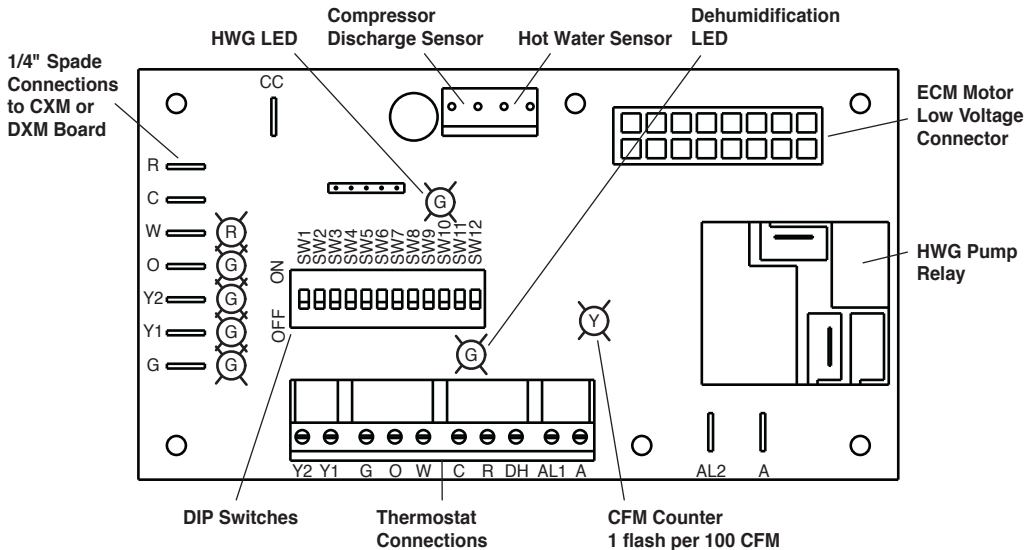

Blower Performance Data

Airflow in CFM with wet coil and clean air filter

Model	Max ESP (in. wg)	Fan Motor (hp)	Tap Setting	Residential Units Only										
				Cooling Mode			Dehumid Mode			Heating Mode			AUX CFM	Aux/ Emerg Mode
				Stg 1	Stg 2	Fan	Stg 1	Stg 2	Fan	Stg 1	Stg 2	Fan		
026	0.50	1/2	4	810	950	475	630	740	475	920	1060	475	4	1060
	0.50	1/2	3	725	850	425	560	660	425	825	950	425	3	950
	0.50	1/2	2	620	730	370	490	570	370	710	820	370	2	820
	0.50	1/2	1	520	610	300				600	690	300	1	690
038	0.50	1/2	4	1120	1400	700	870	1090	700	1120	1400	700	4	1400
	0.50	1/2	3	1000	1250	630	780	980	630	1000	1250	630	3	1350
	0.50	1/2	2	860	1080	540	670	840	540	860	1080	540	2	1350
	0.50	1/2	1	730	900	450				730	900	450	1	1350
049	0.75	1	4	1460	1730	870	1140	1350	870	1560	1850	870	4	1850
	0.75	1	3	1300	1550	780	1020	1210	780	1400	1650	780	3	1660
	0.75	1	2	1120	1330	670	870	1040	670	1200	1430	670	2	1430
	0.75	1	1	940	1120	560				1010	1200	560	1	1350
064	0.75	1	4	1670	2050	1020	1300	1600	1020	1860	2280	1020	4	2280
	0.75	1	3	1500	1825	920	1160	1430	920	1650	2050	920	3	2040
	0.75	1	2	1280	1580	790	1000	1230	790	1430	1750	790	2	1750
	0.75	1	1	1080	1320	660				1200	1470	660	1	1470
072	0.75	1	4	1620	2190	1050	1270	1650	1050	1690	2230	1050	4	2230
	0.75	1	3	1500	1950	980	1170	1520	980	1600	2100	980	3	2100
	0.75	1	2	1400	1830	910	1100	1420	910	1400	1850	910	2	1870
	0.75	1	1	1320	1700	850				1240	1620	850	1	1670

Factory shipped on Tap Setting 2

During Auxiliary operation (residential units only) the CFM will run at the higher if the heating (delay jumper) or AUX settings

Airflow is controlled within +/- 5% up to Max ESP shown with wet coil and standard 1" fiberglass filter

Do not select Dehumidification mode if HP CFM is on setting 1

All units AHRI/ISO/ASHRAE 13256-1 rated HP (Cooling) Delay (Heating) CFM Setting 3

Auxiliary Electric Heat

Auxiliary Heat Ratings

Auxiliary Electric Heat Model	TS, TT Models				Auxiliary Electric Heat Model	TAH Models			kW Rating		Btuh Rating		Minimum CFM Required
	018	024-030	036-038	042-072		026	038	049-064	230V	208V	230V	208V	
AGM4A					AGM4C				3.8	2.9	13000	9900	500
AGM5A					AGM5C				4.8	3.6	16300	12300	500
AGM8A					AGM8C				7.6	5.7	25900	19400	650
AGM10A					AGM10C				9.6	7.2	32700	24600	650
AGL4A					AGL4C				3.8	2.9	13000	9900	500
AGL10A					AGL10C				9.6	7.2	32700	24600	1300
AGL15A					AGL15C				14.4	10.8	49100	36900	1350
AGL20A					AGL20C				19.2	14.4	65500	49200	1350

Black area denotes compatibility

Note: Horizontal units rated for zero clearance unit and 1" clearance for the first three feet of duct, Vertical units rated for zero clearance for both unit and duct.

Auxiliary Heat Electrical Data

Auxiliary Electric Heat Model	Supply Circuit	Heater Amps		Minimum Circuit Amps		Maximum Fuse		Supply Wire	
		230V	208V	230V	208V	230V	208V	Min AWG	Max Ft
AGM4A	Single	15.8	14.0	19.8	17.1	20	20	12	130
AGM5A	Single	20.0	17.3	25.0	21.6	25	25	10	70
AGM8A	Single	31.7	27.5	39.6	34.4	40	35	8	70
AGM10A	Single	40.0	34.7	50.0	43.4	50	45	60	90
AGL4A	Single	15.8	14.0	19.8	17.1	20	20	12	130
AGL10A	Single	40.0	34.7	50.0	43.4	50	45	6	80
AGL15A	Single	60.0	52.0	75.0	65.0	80	70	6	50
	Dual - L1/L3	40.0	34.7	50.0	43.4	50	45	6	80
	Dual - L2/L4	20.0	17.3	25.0	21.6	25	25	10	70
AGL20A	Single	80.0	69.3	100.0	86.6	100	90	2	100
	Dual - L1/L3	40.0	34.7	50.0	43.4	50	45	6	80
	Dual - L2/L4	40.0	34.7	50.0	43.4	50	45	6	80

All heaters rated single phase 208-230V 60Hz
 Wire size based on 60°C (90°C) copper conductor
 All models 15kW or larger feature internal circuit breakers

Wire length based on one way measurement with 2% voltage drop
 All Fuses UL Class K general purpose

Engineering Guide Specifications

General

The water source heating/cooling units shall be vertical upflow air discharge. Units shall be AHRI/ISO/ASHRAE 13256-1 (ground-source closed-loop) performance certified and listed by a nationally recognized safety-testing laboratory or agency. Each unit shall be water run-tested at the factory. Each unit shall be pallet mounted and shipped with appropriate protective packaging to help avoid damage in transportation.

Units shall be warranted by the manufacturer against defects in materials and workmanship for a period ten years on the compressor and refrigerant circuit parts and five years on all remaining parts, with a service labor allowance for the first five years on the compressor and refrigerant circuit parts and two years on all remaining parts. An optional extended labor warranty is available which extends the service labor allowance to ten years for the compressor and refrigeration circuit parts and five years on all remaining parts.

The water source units shall be designed to operate with entering fluid temperature between 20°F and 120°F.

Casing & Cabinet

The cabinet shall be fabricated from heavy-gauge galvanized steel and painted with an epoxy powder coating. The interior shall be insulated with 1/2" thick, multi-density, coated glass fiber. Insulation in the air handler section shall be foil backed for ease of cleaning. Two (vertical), one (horizontal) blower compartment and three compressor compartment access panels shall be provided and shall be removable with supply and return ductwork in place. The internal component layout shall provide for major service with the unit in-place for restricted access installations.

A duct collar (Field installed) shall be provided on the supply air opening. 2" high efficiency MERV11 pleated filters shall be provided with each unit. Units shall have filter frames. The units shall have an insulated divider panel between the air handling section and the compressor section to minimize the transmission of compressor noise, and to permit operational service testing without air bypass. Units shall be supplied with left or right air inlet.

Refrigerant Circuit

All units shall contain EarthPure® (HFC-410A) sealed refrigerant circuit employing a hermetic motor-compressor, bidirectional thermal expansion valve, finned tube air-to-refrigerant heat exchanger, reversing valve, coaxial tube water-to-refrigerant heat exchanger and service ports. An optional Hot Water Generator (desuperheater) coil shall be provided.

Compressors shall be Copeland UltraTech™ Two-Stage scroll type designed for heat pump duty and mounted on vibration isolators. Compressor motors shall be single phase PSC with internal overload protection. A factory installed bidirectional filter drier shall be provided on all models. The finned tube coil shall be sized for low-face velocity and constructed of lanced aluminum fins bonded to rifled copper tubes in a staggered pattern not less than three rows deep. Entire air coil surface shall be tin plated for corrosion protection.

The coaxial water-to-refrigerant heat exchangers shall be designed for close approach temperatures and be constructed of a convoluted copper (optional cupro-nickel) inner tube and a steel outer tube. The thermal expansion valves shall provide proper superheat over the entire fluid temperature range with minimal "hunting". The valve shall operate bi-directionally without the use of check valves.

The water-to-refrigerant heat exchanger and refrigerant suction lines shall be insulated to prevent condensation at low liquid temperatures.

Fan Motor and Blower

The fan shall be a direct drive centrifugal type with a dynamically balanced wheel. The housing and wheel shall be designed for quiet low outlet velocity operation and of galvanized steel construction. Tight fan housing geometry shall not be permitted. The fan housing shall be removable from the unit without disconnecting the supply air ductwork for servicing of the fan motor. The fan motor shall be an ECM variable speed type. The ECM fan motor shall provide soft starting, maintain constant CFM over its static operating range and provide airflow adjustment on its control board. The fan motor shall be isolated from the housing by rubber grommets. The motor shall be permanently lubricated and have thermal overload protection.

Electrical

CXM Control - A microprocessor-based compressor controller shall be provided to monitor and control unit operation. The control shall provide compressor and electric heater sequencing, high and low pressure monitoring, field selectable water and air coil low temperature protection sensing, condensate overflow sensing, over/under voltage monitoring, and unit performance sentinel (UPS). The control shall also provide for water valve connection, a test mode, short cycle protection, random start-up, as well as fault LED, fault memory, and intelligent fault retry.

The control shall employ quick attach harness assemblies for low voltage connections to the control board to aid in troubleshooting or replacement. An integral terminal block with screw terminals shall be provided on the control for all field low voltage connections. A circuit breaker protected 75VA transformer shall be employed. Line voltage box lugs shall be provided for unit wiring. Units shall have knockouts for entrance of low and line voltage wiring. The fan motor and control box shall be harness plug-connected for easy removal.

Residential models shall have a dual circuit-breaker protected power block for the connection of external flow controller pump module.

Piping

Supply and return water connections, as well as Hot Water Generator (desuperheater) connections shall be 1" FPT (Female Pipe Thread) brass swivel fittings which provide a union and eliminate the need for pipe wrenches and sealants when making field connections. A thread by sweat fitting shall be provided for connection to the water heater. All water piping shall be insulated to prevent condensation at low liquid temperatures.

The condensate connection shall be a 3/4" PVC glue (socket) with internal-trap (Vertical Models).

Accessories & Warranty

Accessories & Options

ClimaDry™ Whole House Dehumidification

An optional internal whole house dehumidifier shall be factory installed, which allows the unit to operate in one of three modes, heating, cooling, or dehumidification. Operation must include modulating controls to provide neutral air (72°F) regardless of entering water temperature. Requires ATP32U04 thermostat or separate humidistat. See the ClimaDry Installation Guide/Application Manual for more details and unit availability.

Hot Water Generator

An optional insulated heat reclaiming desuperheater coil of vented double-wall copper construction suitable for potable water shall be provided. The coil and hot water circulating pump shall be factory mounted inside the unit. A high limit and low compressor discharge line temperature switch shall be provided to disable the pump when these conditions occur.

Cupro-Nickel Heat Exchanger

An optional corrosion resistant CuNi coaxial heat exchanger shall be factory installed in lieu of standard copper construction.

Thermostat (field installed)

A multistage auto-changeover electronic digital thermostat shall be provided. The thermostat shall offer 3 heating and 2 cooling stages with precise temperature control. An OFF-HEAT-AUTO-COOL-EMERG system switch, OFF-AUTO fan switch, and indicating LED's shall be provided. The thermostat shall read out in °F or °C. An optional remote indoor sensor and outdoor sensor use shall be available on some models.

Flow Controller (field installed)

A self-contained module shall provide all fluid pumping, fill and connection requirements for ground-source closed-loop systems up to 20 GPM. The Flow Controller shall provide 1" pump isolation valves and 3-way service valves. Pump heads shall be removable from the volute for easy replacement. The Flow Controller shall be enclosed in a polystyrene case and fully insulated with urethane foam to prevent condensation.

Auxiliary Heater (field installed)

An internal, field-installed electric heater shall provide supplemental and/or emergency heating capability when used with the three stage heating thermostat. (Heater is externally mounted on horizontal units).

Hose Connection Kit (field installed)

An accessory hose kit shall provide 150psi 1" rubber hose with brass fittings equipped with service pressure/temperature ports for connection between the unit and Flow Controller.

Warranty Information

The 2010 standard warranty applies to units ordered on or after May 1, 2010. See ClimateMaster's 2010 Limited Express Residential Warranty Certificate RP851 for specific coverage and limitation.

ClimateMaster residential class heat pumps are backed by a ten-year limited warranty on all unit parts, including the following accessories when installed with ClimateMaster units: Flow Controllers, Thermostats & Electric Heaters.

ClimateMaster goes even further to back up its commitment to quality by including a service labor allowance for the first five years on unit parts and thermostats, auxiliary electric heaters and geothermal pumping modules.

The Optional Extended Factory Service Labor Allowance Warranty offers additional length of term protection to the consumer by offsetting service labor costs for 10 years.

To order this warranty, contact your ClimateMaster distributor. This coverage must be purchased within 90 days of unit installation. See Limited Express Extended Labor Warranty Certificate RP852 for details.

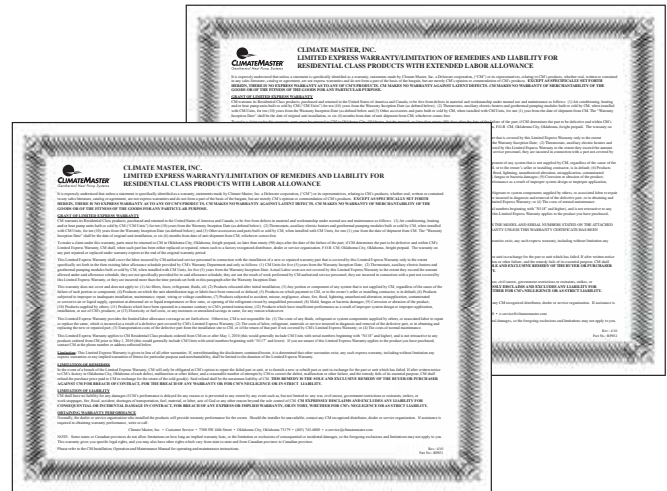

Revision History

Date	Page #	Description
24 Sept., 10	77	Note Added for Electric Heat
24 Sept., 10	78	Electrical Data Updated
25 Aug., 10	77	Horizontal units supply air dimension M and Q updated
26 July, 10	Wire Diagram Pages	Wire Diagram revision: water-side high pressure switches added
14 July, 10	85	Compressor isolation upgrade from Springs to grommets
4 June, 10	77	Dim. M & Q Changed
8 June, 09	Various	Edits to pages 49, 52, 53, 79-82, and 86
05 June, 08	All	Reformatted Document Size
03 Mar, 08	37	Updated Specifications
03 Mar, 08	26	Updated Downflow Dimensional Data
01 Mar, 07	30	Added New Notes to Electrical Data
01 Mar, 07	All	Added Model 072 Information
01 Oct, 06	All	First Published