

INSTALLATION AND OPERATING INSTRUCTION MANUAL

ClimateMaster
A COMBINATION OF CHP CORP. AND
FRIEDRICH™ CLIMATE MASTER, INC.

CONTENTS

| | |
|------|--|
| I | General Construction, Model Designations |
| II | Dimensions |
| III | Installing the Equipment |
| IV | Ductwork |
| V | Condensate Drains |
| VI | Electrical Connections |
| VII | Room Thermostats |
| VIII | Water Connections |
| IX | Start-Up Instructions |
| X | Maintenance Procedures |
| XI | General Service Guide |
| XII | Typical Wiring Diagrams |
| XIII | Parts List |

Models Covered:

| | |
|---------|---------|
| SIZE 4 | 802 041 |
| SIZE 5 | 802 051 |
| SIZE 7 | 802 071 |
| SIZE 9 | 802 092 |
| SIZE 12 | 802 122 |
| SIZE 14 | 802 142 |
| SIZE 22 | 802 222 |
| SIZE 26 | 802 262 |

WATER-TO-AIR
DOWNFLOW ROOFTOP UNITS

802 SERIES

I GENERAL CONSTRUCTION, MODEL DESIGNATION

Rooftop units covered by this manual are heat pumps, with or without supplementary electric resistance heating.

All units include a condensing unit section (compressors, water-to-refrigerant heat exchanger, and controls) and an air handling section (evaporator, filters, blowers, optional resistance heaters) mounted on an integral base.

All units are factory charged with refrigerant, factory-tested to insure proper operation and performance, and factory wired to single-point power termination points.

The entire bottom of the unit is covered by 3/8" thick foamed plastic insulation, which provides water tight seal when the unit is dropped on its factory-built steel curb. The insulation also provides sound attenuation and thermal insulation.

Standard and optional components include those listed below. Some models include only those listed as standard; others may have one or more options included, as determined by the specifications covering the specific job.

A. COMPRESSOR SECTION

1. Standard Components

- Compressor (two in some models)
- Refrigerant-to-water heat exchanger(s)
- Water piping sleeves thru base
- Crankcase heater for each compressor
- High and Low pressure safety controls for each compressor
- Refrigerant Drier
- Refrigerant Reversing Valve
- Suction Accumulator
- High and Low Pressure Service Gauge Ports and Valves

2. Optional Components

- Five-minute anti-recycling relay (assures at least five-minute off period any time compressor stops)
- "Sure-trip" phase monitor (stops the unit any time one phase is lost on three-phase models)
- Exhaust fan interlock relay
- Resistance heater lockout thermostat (on heat pumps to lock out resistance heat above a predetermined ambient temperature)

B. ELECTRICAL CONTROL PANEL

1. Standard Components

- Compressor contactor or contactors
- 24 volt transformer to furnish control voltage
- Evaporator blower contactor or starter (located on bulkhead wall in its own enclosure on larger models)
- On some models, the refrigerant pressure controls may be located in the electrical box enclosure
- Low voltage terminal board
- Heating relay
- "Singlepoint" connection terminal board for dual compressor models or models with resistance heaters.

C. AIR HANDLING SECTION

1. Standard Components

- Evaporator coil (dual circuit on some models)
- Thermal expansion valves
- Evaporator condensate drain pan
- Blower (two on many models)... blowers are ball-bearing type
- Evaporator blower motor (ball-bearing type on most models)
- Air filters

2. Optional Components

- Electric resistance heaters w/required contactors, protectors and fusing
- Permanent filters
- Outdoor air damper, either manual or motorized
- Firestat mounted
- Economizer System

DIMENSIONS

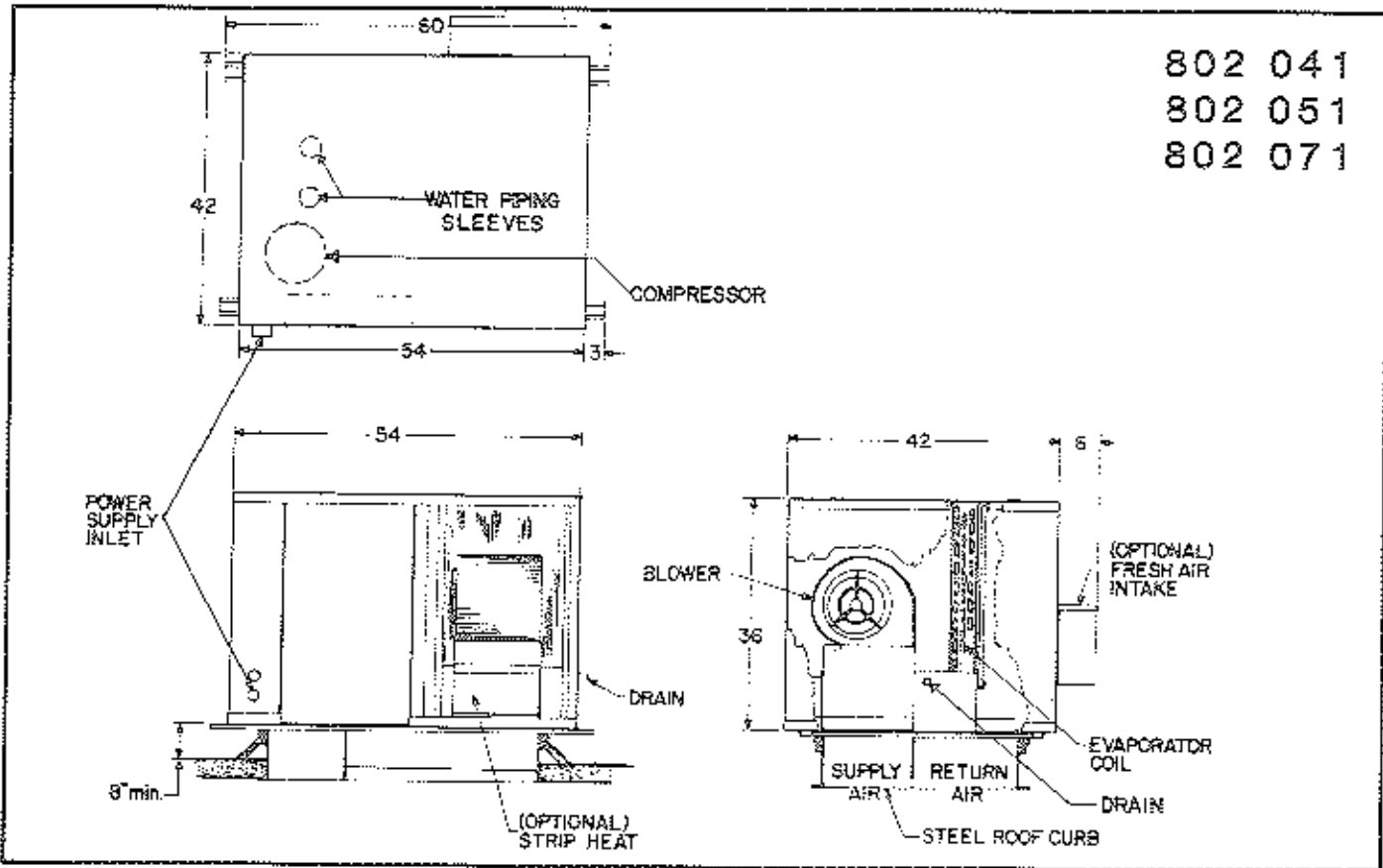

503 CURB

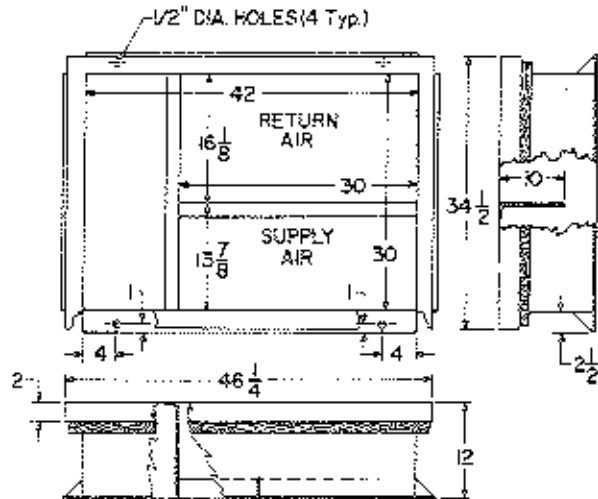
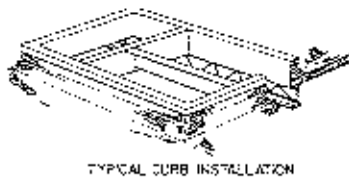

Shaded Area Indicate 3' Clearance must be left for access to Compressor and Electrical Panel.

DIMENSIONS

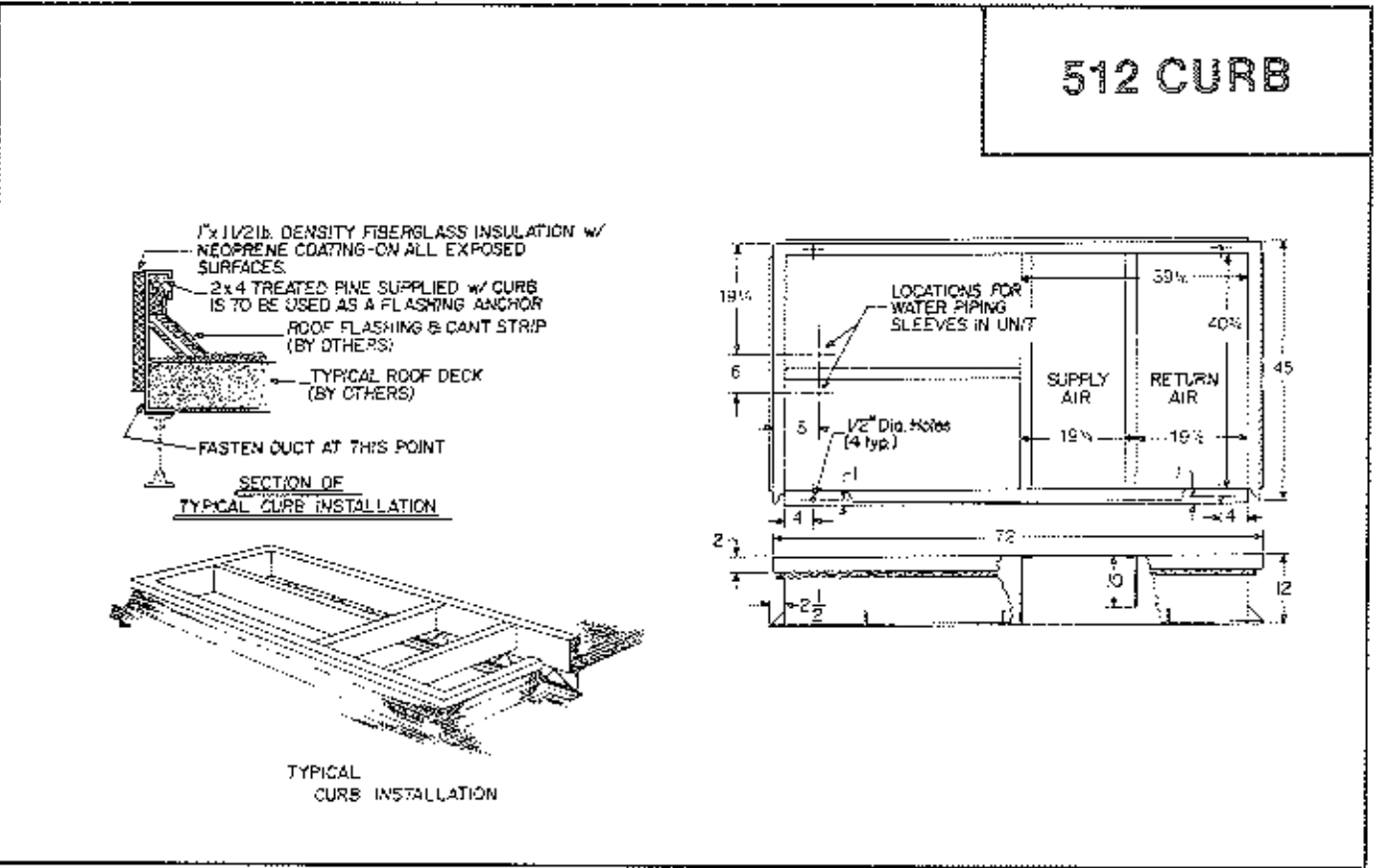
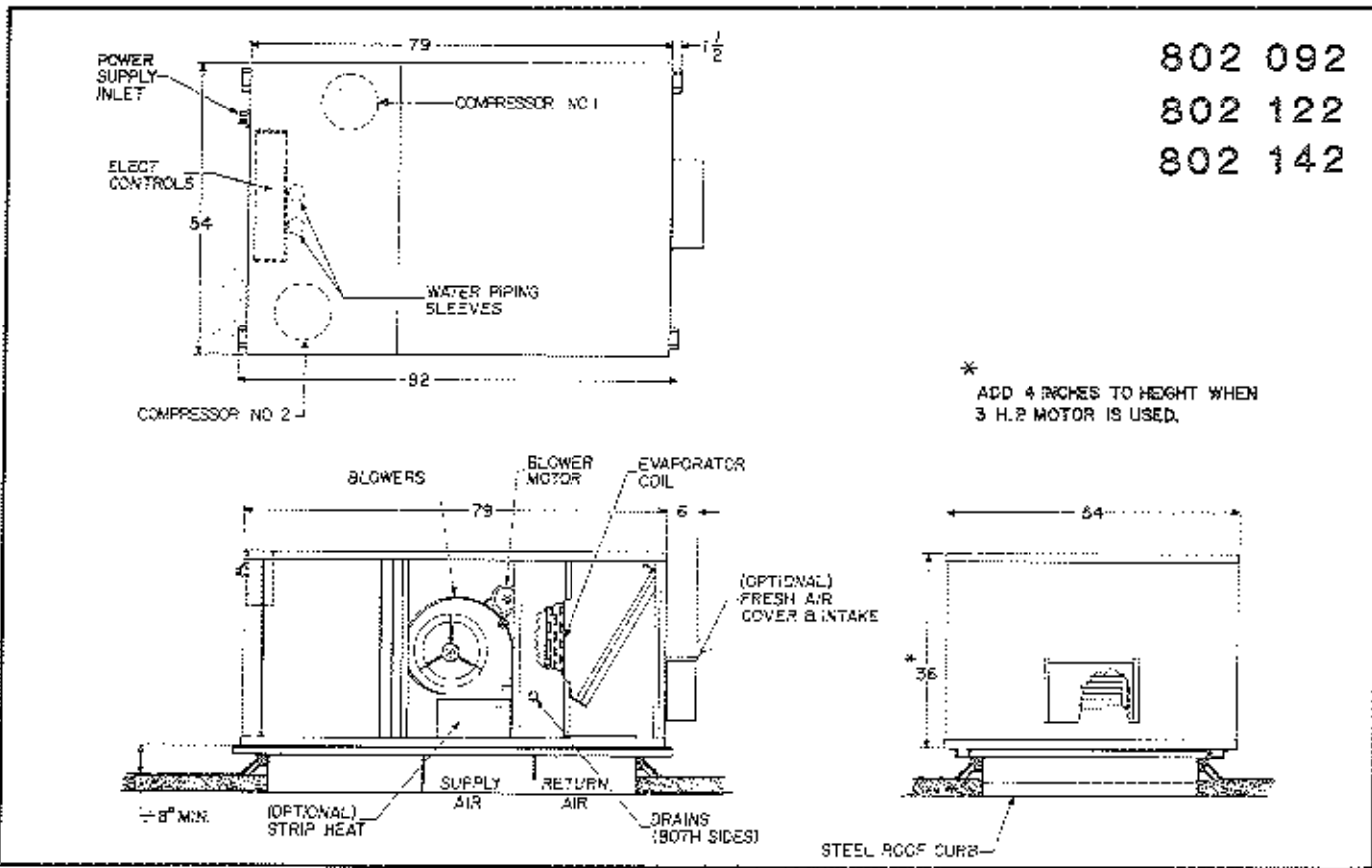

Shaded Area indicate 3' Clearance must be left for access to Compressor and Electrical Panel.

DIMENSIONS

802 222

802 262

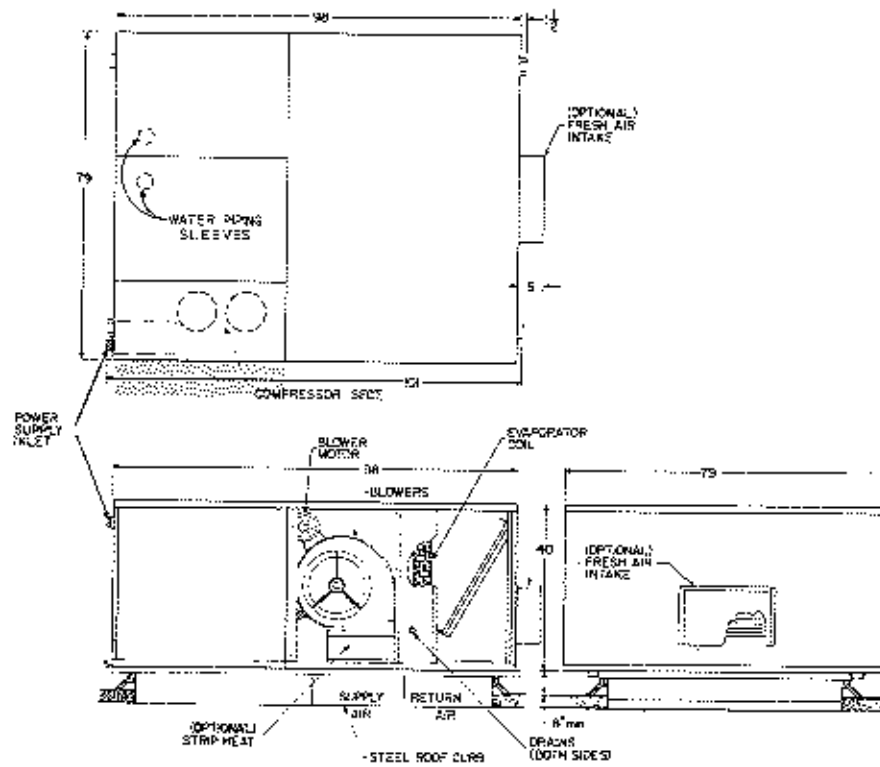

505 CURB

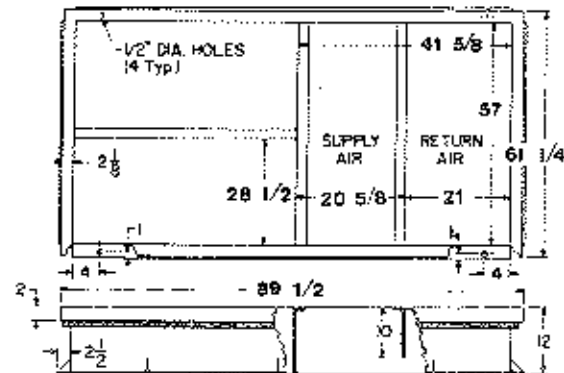
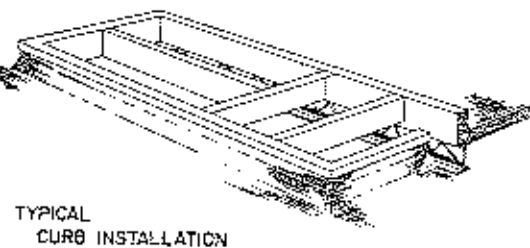
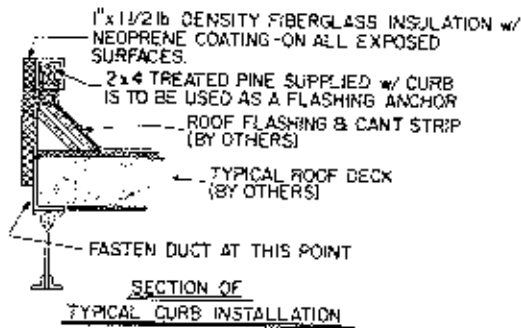

Shaded Area Indicate 3' Clearance must be left for access to Compressor and Electrical Panel.

III INSTALLING THE EQUIPMENT

1. Inspect unit for shipping damage. Report any damage to the delivering trucking company at once.
2. Unit is shipped on wood skids to protect it from accidental damage, and to permit easy handling and moving.
3. ALWAYS move and lift units in the UPRIGHT HORIZONTAL position.
4. Spreader bars must be used to protect the cabinet from damage. These are furnished by the Rigger.
5. Do not attach slings through the cabinet, or to any piping or panels.
6. Lower unit on to curb gently, and make sure it is centered so that the base rails fit down over curb and gasket seals evenly. Be sure unit is positioned correctly end for end, so the supply and return air openings match with those in the curb.
7. Allow unit to set in place 24 hrs. after rigging before starting.

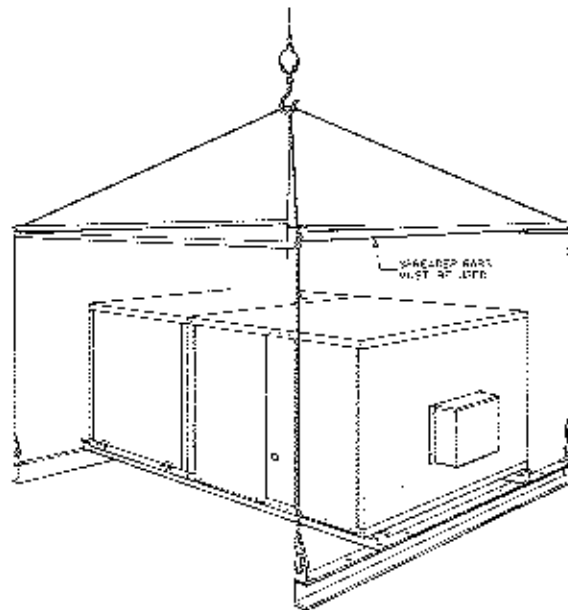

FAN PERFORMANCE DATA

| 802 | CFM | EXTERNAL STATIC PRESSURE, INCHES W.C. | | | | | | | | | |
|-----|------|---------------------------------------|--------|--------|--------|--------|--------|--------|--------|--------|--------|
| | | 0.2" | | 0.4" | | 0.6" | | 0.8" | | 1.0" | |
| | | R.P.M. | B.H.P. | R.P.M. | B.H.P. | R.P.M. | B.H.P. | R.P.M. | B.H.P. | R.P.M. | B.H.P. |
| 041 | 1300 | 830 | .3 | 920 | .4 | 1010 | .5 | 1100 | .6 | 1190 | .7 |
| | 1500 | 880 | .3 | 970 | .4 | 1060 | .5 | 1150 | .6 | 1240 | .7 |
| | 1700 | 930 | .4 | 1020 | .5 | 1110 | .6 | 1200 | .7 | 1290 | .8 |
| 051 | 1550 | 930 | .4 | 1010 | .5 | 1090 | .6 | 1170 | .7 | 1250 | .8 |
| | 1750 | 980 | .5 | 1060 | .6 | 1140 | .7 | 1220 | .8 | 1300 | .9 |
| | 1950 | 1030 | .5 | 1110 | .6 | 1190 | .7 | 1270 | .8 | 1350 | .9 |
| 071 | 1900 | 1090 | .8 | 1160 | .9 | 1230 | 1.0 | 1300 | 1.1 | 1370 | 1.2 |
| | 2100 | 1140 | .8 | 1210 | .9 | 1280 | 1.0 | 1350 | 1.1 | 1420 | 1.2 |
| | 2300 | 1190 | .9 | 1260 | 1.0 | 1330 | 1.1 | 1400 | 1.2 | 1470 | 1.3 |
| 092 | 2900 | 750 | .6 | 825 | .8 | 900 | 1.0 | 975 | 1.2 | 1050 | 1.4 |
| | 3200 | 800 | .8 | 875 | 1.0 | 950 | 1.2 | 1025 | 1.4 | 1100 | 1.6 |
| | 3500 | 850 | 1.0 | 925 | 1.2 | 1000 | 1.4 | 1075 | 1.6 | 1150 | 1.8 |
| 122 | 3100 | 860 | 1.0 | 930 | 1.2 | 1000 | 1.4 | 1070 | 1.6 | 1140 | 1.8 |
| | 3500 | 910 | 1.2 | 980 | 1.4 | 1050 | 1.6 | 1120 | 1.8 | 1190 | 2.0 |
| | 3900 | 960 | 1.4 | 1030 | 1.6 | 1100 | 1.8 | 1170 | 2.0 | 1240 | 2.2 |
| 142 | 3600 | 960 | 1.6 | 1020 | 1.8 | 1080 | 2.0 | 1140 | 2.2 | 1200 | 2.4 |
| | 4000 | 1010 | 1.8 | 1070 | 2.0 | 1130 | 2.2 | 1190 | 2.4 | 1250 | 2.6 |
| | 4400 | 1060 | 2.0 | 1120 | 2.2 | 1180 | 2.4 | 1240 | 2.6 | 1300 | 2.8 |
| 222 | 6100 | 690 | 1.8 | 740 | 2.2 | 790 | 2.4 | 840 | 2.6 | 890 | 2.9 |
| | 6800 | 730 | 2.2 | 780 | 2.6 | 830 | 2.8 | 880 | 3.0 | 930 | 3.3 |
| | 7500 | 770 | 2.6 | 820 | 3.0 | 870 | 3.2 | 920 | 3.4 | 970 | 3.7 |
| 252 | 7200 | 790 | 3.0 | 835 | 3.4 | 880 | 3.8 | 925 | 4.2 | 970 | 4.6 |
| | 8000 | 830 | 3.4 | 875 | 3.8 | 920 | 4.2 | 965 | 4.6 | 1010 | 5.0 |

Above Ratings without Electric Heaters Installed. Add .9 20" to Each Static to Arrive at Total F.S.P. when using Electric Heaters.

IV DUCTWORK

Duct connections may be made to the factory fabricated steel roof curb even before the unit is set. Return and supply connections are shown on the dimensional drawings in Section II.

Typical dimensions for single-return air concentric duct diffusers are shown in Section II. Steel curbs are fully insulated with 1" thick, 1½ lb. density, neoprene coated insulation, but 2" is left uninsulated for making duct connections. Drill directly into the side of the curb to make connections, in the bottom 2" uninsulated strip. This portion of the curb is below the roofing and no leakage will result.

Standard blower drives have been selected to provide rated unit airflow up to approximately 0.6 to 0.7 inches

external static pressure. Unless otherwise specified, drives are factory set to furnish rated air at .6" static. Contact factory if any unusual static pressure conditions prevail which would require consideration of other drives.

All ductwork must be installed according to local codes, practices and requirements. Ducts passing through unconditioned spaces must be well insulated, with vapor barrier to prevent condensation.

Heat pumps are very sensitive to reduced airflow on the heating cycle. Reduced airflow results in high compressor head pressures, inefficient operation and possible nuisance trips of the high pressure control. Always design for full airflow on heat pumps, and insist on frequent filter cleaning.

V CONDENSATE DRAINS

IMPORTANT: Always install drain trap as shown on sticker on side of unit. Always plug the unused drain opening. Failure to follow these instructions may result in improper drainage.

Size 7 and larger units have condensate drain openings on both sides of the unit. Since the unit may not sit exactly level, always use the lowest drain (check unit with carpenter's level to determine lowest drain).

INSTALL CONDENSATE DRAIN TRAP (CONNECTED TO PIPE OUTLET) AS SHOWN BELOW. DO NOT OPERATE UNIT WITHOUT TRAP. UNIT MUST BE LEVEL OR SLIGHTLY INCLINED TOWARDS DRAIN.



527-17

VI ELECTRICAL CONNECTIONS

Electric power openings are located adjacent to the unit electrical control box. On some models, connections may be located in water-tight enclosure on side of the unit; this box may in some cases include a disconnect switch and/or a terminal board. Line voltage terminals may be located on the contactor in some models, a separate terminal board on some models, or in the external box on other models. Check the wiring diagram in the control box cover of the unit you have to locate the terminals.

Typical ampacity and fusing requirements are included in the following tables. However, they are typical, and you should always check the rating plate of the unit you have to determine ampacities and fusing required for your unit.

Most codes require a disconnect switch within sight of the unit. Follow codes applicable in your area.

If your unit includes electric resistance heaters, they have been separately fused if so required by the National Electric Code.

Note: All unit connections are for copper wire only. DO NOT USE ALUMINUM WIRES ON THE TERMINALS OF THIS UNIT.

Note: Many units have three phase blower motors, which will run backward if the phases are not correct. Always check for correct blower rotation, and if it is wrong, interchange any two of the main power leads to the unit.

Note: If unit is equipped with "Sure-Trip" phase monitor, system will not operate unless phases are correct.

Voltage Levels

Abnormally high or low voltage can result in damage to equipment. Always check to see that voltage is within 5% of nameplate rating during normal operation. Unit should function at voltages within 10% of nameplate rating, but if the voltage consistently runs 10% high or low, consult your power company and insist on better voltage level or regulation.

ELECTRICAL DATA

*For Units without Electric heat only.

UNITS WITH STANDARD FAN MOTOR

| | | 041 | 051 | 071 | 092 | 122 | 142 | 222 | 262 |
|---------------------------------------|----------|------|------|------|------|------|------|------|-------|
| MIN. CIRCUIT AMPACITY | 208-3-60 | 21.0 | 20.9 | 27.4 | 31.5 | 42.7 | 48.7 | 82.0 | 103.0 |
| | 230-3-60 | 21.0 | 20.5 | 27.0 | 31.1 | 42.7 | 48.7 | 80.5 | 101.0 |
| | 460-3-60 | 9.2 | 10.6 | 13.7 | 15.5 | 20.4 | 24.7 | 37.3 | 47.3 |
| MAX. FUSE SIZE (Dual Element Fuse) | 208-3-60 | 30 | 30 | 45 | 40 | 50 | 60 | 110 | 125 |
| | 230-3-60 | 30 | 30 | 45 | 40 | 50 | 60 | 110 | 125 |
| | 460-3-60 | 15 | 15 | 20 | 20 | 25 | 30 | 50 | 60 |

*For Units with Electric heat see nameplate.

UNITS WITH UPSIZED FAN MOTOR

| | | | | | | | | | |
|---------------------------------------|----------|------|------|------|------|------|------|------|-------|
| MIN. CIRCUIT AMPACITY | 208-3-60 | 19.3 | 22.5 | 29.0 | 33.1 | 43.7 | 53.3 | 87.3 | 111.0 |
| | 230-3-60 | 19.0 | 22.5 | 29.0 | 33.1 | 43.7 | 51.9 | 85.1 | 109.0 |
| | 460-3-60 | 9.4 | 11.6 | 14.6 | 16.5 | 20.9 | 26.3 | 39.6 | 51.1 |
| MAX. FUSE SIZE (Dual Element Fuse) | 208-3-60 | 30 | 35 | 45 | 45 | 60 | 70 | 110 | 125 |
| | 230-3-60 | 30 | 35 | 45 | 45 | 60 | 70 | 110 | 125 |
| | 460-3-60 | 15 | 15 | 20 | 20 | 25 | 35 | 50 | 60 |

*For Units with Electric heat see nameplate.

COMPRESSOR

| | | | | | | | | | |
|-----|----------|------|------|-------|------|-------|-------|-------|-------|
| RLA | 208-3-60 | 12.2 | 13.5 | 18.7 | 12.2 | 16.5 | 18.7 | 31.4 | 38.5 |
| | 230-3-60 | 12.2 | 13.5 | 18.7 | 12.2 | 16.5 | 18.7 | 31.4 | 38.5 |
| | 460-3-60 | 6.1 | 7.0 | 9.5 | 6.1 | 7.8 | 9.5 | 14.4 | 17.8 |
| LRA | 208-3-60 | 72.0 | 93.0 | 126.0 | 72.0 | 103.0 | 126.0 | 183.0 | 229.0 |
| | 230-3-60 | 72.0 | 93.0 | 126.0 | 72.0 | 103.0 | 126.0 | 183.0 | 229.0 |
| | 460-3-60 | 35.0 | 47.0 | 62.0 | 35.0 | 54.0 | 62.0 | 93.3 | 118.0 |

SUPPLY FAN MOTORS

| HP | 208-3-60 | | 230-3-60 | | 460-3-60 | |
|-------|----------|-------|----------|------|----------|------|
| | FLA | LRA | FLA | LRA | FLA | LRA |
| 1/2 | 4.3 | 25.8 | 4.3 | 25.8 | 1.1 | 6.6 |
| 3/4 | 5.7 | 34.2 | 5.7 | 34.2 | 1.6 | 10.8 |
| 1 | 4.0 | 24.2 | 3.6 | 21.0 | 1.8 | 10.7 |
| 1 1/2 | 5.6 | 35.0 | 5.6 | 30.4 | 2.8 | 15.2 |
| 2 | 6.6 | 39.0 | 6.6 | 39.2 | 3.3 | 19.7 |
| 3 | 11.3 | 61.9 | 9.8 | 54.2 | 4.9 | 37.6 |
| 5 | 16.6 | 104.0 | 14.4 | 82.0 | 7.2 | 44.6 |

VII ROOM THERMOSTATS

Special control circuits, systems and panels are often used with these commercial models. Specified jobs will usually have their own control circuitry separately designed, and diagrams must be consulted for control wiring and thermostats.

Special Note: When special control circuits are used that may incorporate time-clocks to start and stop the unit, **be sure that they do not interrupt line voltage to the unit.** This would result in de-energizing the compressor crankcase heater, and result in damage to the compressor upon start-up. Such time clocks should only interrupt the control voltage.

TYPICAL FIELD WIRING CONNECTIONS 802 041, 051 AND 071

UNIT LOW VOLTAGE TERMINAL BOARD

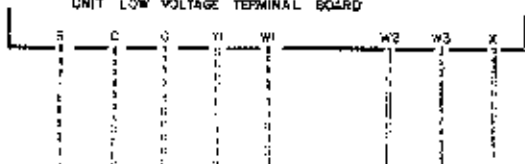

| | | | | | | | |
|--------------|----|----|----|----|----|----|----|
| 7800-44E/447 | R | O | Y | W1 | W2 | W3 | X |
| 780-24/25 | R | O | Y | W1 | W2 | W3 | X |
| 7800-36A | R | O | Y | W1 | W2 | W3 | X |
| 843-120/121 | X | C | O | Y1 | W1 | W2 | W3 |
| 843-162 | R | O | Y1 | W1 | W2 | W3 | X |
| 843-165/167 | R | X | C | Y | W1 | W2 | W3 |
| 8403-171 | R | C | O | Y1 | W1 | W2 | W3 |
| 843-174 | L1 | L2 | RN | RV | H1 | H2 | H3 |

FIG. 1

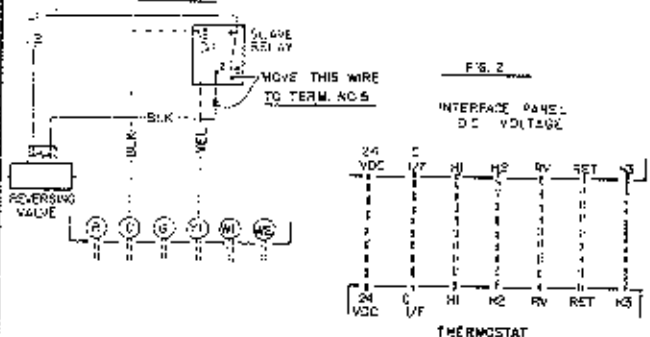

TYPICAL FIELD WIRING CONNECTIONS 802 092, 122, 142, 222 AND 262

UNIT LOW VOLTAGE TERMINAL BOARD

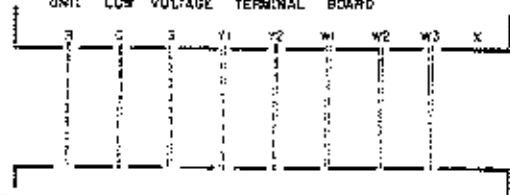

| | | | | | | | | |
|-------------|----|----|----|----|----|----|----|---|
| 843-63 | R | O | Y1 | Y2 | W1 | W2 | W3 | X |
| 843-118/119 | R | O | Y1 | Y2 | W1 | W2 | W3 | X |
| 843-14 | L1 | L2 | RN | RV | H1 | H2 | H3 | X |

FIG. 1

INTERFACE PANEL
DC VOLTAGE

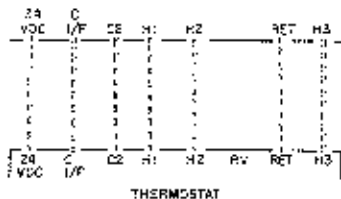

- OPT Field Low Voltage Wiring required only with Elect. Heat
- Field Low Voltage Wiring
- Field Jumper required between RC and RH (RH term. not shown)
- △ Additional Field Low Voltage Wiring required see Fig. 1 Note, terminals shown in Table are 24VAC from unit to interface panel and Fig. 1 shows 24VDC wiring from interface panel to thermostat.

VIII WATER CONNECTIONS

Water connections are inside the unit, in the compressor compartment. There are two pipe sleeves in the bottom pan of the unit, and the water lines must be brought up to the roof through the curb. Dimensions locating the sleeve centerlines are shown on the dimensional drawings.

Water connections are I.D. Copper Sweat, as follows:

Size 041— $\frac{3}{4}$ " Size 092—1" Size 222—2"
 Size 051— $\frac{3}{4}$ " Size 122—1" Size 262—2"
 Size 071—1" Size 142—2"

Where the two condensers are used, they are manifolded at the factory, so only two connections are required in the field.

Follow all local plumbing codes in connecting water lines, and insulate against freezing.

Most of these units will be installed on closed loop systems. If well water is used, an adequate supply of good water must be available. If it is high in mineral content, it may need to be treated to keep the heat exchanger from "liming up". If high in sulfur content, an optional Cupro-Nickel condenser may need to be specified. Consult local water treatment companies for advice on the condition of the water you intend to use.

The table below shows condenser water pressure drop at different water flow rates for each model.

| CONDENSER WATER PRESSURE DROP | | | | | | | | | | | | | | | |
|-------------------------------|-----|-----|------|-----|-----|-----|-----|-----|-----|-----|-----|-----|-----|-----|------|
| 041 | | 051 | | 071 | | 092 | | 122 | | 142 | | 222 | | 262 | |
| GPM | PSI | GPM | PSI | GPM | PSI | GPM | PSI | GPM | PSI | GPM | PSI | GPM | PSI | GPM | PSI |
| 7 | 2.4 | 9 | 3.6 | 12 | 4.8 | 18 | 2.4 | 22 | 3.0 | 28 | 1.5 | 32 | 3.1 | 40 | 5.1 |
| 8 | 3.0 | 10 | 4.6 | 13 | 4.5 | 20 | 2.7 | 24 | 3.4 | 28 | 2.3 | 36 | 4.7 | 44 | 6.1 |
| 9 | 3.8 | 11 | 5.5 | 14 | 5.0 | 22 | 3.0 | 26 | 3.8 | 30 | 2.5 | 40 | 6.0 | 48 | 7.1 |
| 10 | 4.6 | 12 | 6.4 | 15 | 5.6 | 24 | 3.4 | 28 | 4.2 | 32 | 3.1 | 44 | 6.7 | 52 | 8.1 |
| 11 | 5.5 | 13 | 7.3 | 16 | 6.1 | 26 | 3.8 | 30 | 4.5 | 34 | 3.8 | 48 | 7.1 | 56 | 9.1 |
| 12 | 6.4 | 14 | 8.5 | 17 | 6.6 | 28 | 4.1 | 32 | 4.9 | 38 | 4.1 | 52 | 8.1 | 60 | 10.1 |
| 13 | 7.3 | 15 | 10.0 | 18 | 7.1 | 30 | 4.5 | 34 | 5.4 | 38 | 4.6 | 56 | 9.1 | 64 | 11.1 |

NOTE—Above values with new clean condenser surface.

TO MEASURE WATER FLOW: Pressure taps are provided on each water connection, in order to measure water pressure at the inlet and outlet. This will allow the pressure drop across the unit to be determined, and the table above will indicate water flow in GPM.

Rated flow in accordance with applicable ARI standards is that rate which gives a 10 degree F. water temperature rise on the cooling cycle, at rated CFM, 80 F. dry bulb and 67 F. wet bulb air across the evaporator coil.

Size 041— 12 gpm Size 122— 32 gpm
 Size 051— 14 gpm Size 142— 36 gpm
 Size 071— 18 gpm Size 222— 50 gpm
 Size 092— 28 gpm Size 262— 60 gpm

However, for most closed loop applications, the recommended flow rate will vary according to inlet water temperature.

| RECOMMENDED WATER FLOW—CLOSED LOOP APPLICATION (GPM) | | | | | | | | |
|--|------|------|------|------|------|------|------|------|
| INLET WATER TEMP. | SIZE | SIZE | SIZE | SIZE | SIZE | SIZE | SIZE | SIZE |
| | 041 | 051 | 071 | 092 | 122 | 142 | 222 | 262 |
| 65 | 5.5 | 6.4 | 8.3 | 13 | 15 | 17 | 23 | 28 |
| 70 | 6.5 | 7.6 | 9.7 | 15 | 17 | 19 | 27 | 32 |
| 75 | 7.9 | 9.2 | 12 | 18 | 21 | 24 | 33 | 40 |
| 80 | 9.6 | 11 | 14 | 22 | 25 | 29 | 40 | 48 |
| 85 | 12 | 14 | 18 | 26 | 32 | 36 | 50 | 60 |
| 90 | 12 | 14 | 18 | 28 | 32 | 36 | 50 | 60 |

IX START-UP INSTRUCTIONS

The following steps are offered as a general guide to start-up:

- a. With a voltmeter, check to see that the voltage to be applied to the unit is correct. If it is low by more than 10%, consult the power company before starting the unit. If it is high, watch carefully to see that it does not remain more than 10% high during full load running conditions.
- b. **ALL UNITS ARE EQUIPPED WITH COMPRESSOR CRANKCASE HEATERS, WHICH MUST BE ENERGIZED AT LEAST 12 HOURS PRIOR TO START-UP.**

Before turning power on to the unit, see that the thermostat switch is in the OFF position. Then turn power on. Allow it to remain on at least 12 hours prior to starting the unit.
- c. Feel the compressor crankcase. It should be warm, since the heaters have been on at least 12 hours. This will assure that no refrigerant liquid is present in the crankcase. If the crankcase is allowed to contain liquid refrigerant, compressor damage or failure can occur on start-up.
- d. Install suction and discharge gauge set on compressor, to read suction and discharge pressure.
- e. Turn the thermostat Fan Switch to the ON position. The supply air blower should operate. Observe that airflow is present. Measure that airflow in order to determine if it is as specified for the particular application. Normal methods of measurement should be used, as with any commercial installation. Since blower motor is three-phase, check to be sure it is not running backwards. If it is, interchange any two of the three power leads to the unit, after first stopping the unit and opening the disconnect to remove power from the unit.
- f. Be sure that water flow to the unit is correct. Section VIII gives correct pressure drop readings across the condenser; Schrader fittings are provided to read that pressure drop. Water flow should be as specified for the job.
- g. After being satisfied that airflow and water flow are correct, turn the temperature setting on the thermostat as high as it will go. Then turn the system switch to COOL. The unit compressor should not come on yet. Then, slowly turn the temperature setting down until the thermostat contacts make, calling for cooling. The compressor should now come on. Check to see that it is operating correctly. If compressor is equipped with an oil level sight glass, check for proper oil level.
- h. With a voltmeter, check to see that the unit is receiving rated voltage while running. If it remains more than 10% low or high during full load running conditions, consult the power company.
- i. With an ammeter, check to see that the unit is drawing approximately rated current in amps.
- j. Check pressure readings on the suction and discharge gauges. While these will vary with start-up conditions, suction pressure will usually be from 65 to 80 psig, and the discharge pressure will usually be from 210 to 240 psig. Not until the room temperature conditions have been brought to normal can you check pressures closer.
- k. Check superheat at the suction line just before the compressor. . . it should be about 15 degrees during normal operation.
- l. After checking the cooling operation, turn the thermostat to the OFF position, and listen for the unit reversing valve to shift. Then, turn the temperature setting as low as it will go. Switch to the HEAT position. Then, gradually raise the temperature setting until the compressor comes on. See that the unit is providing heat. The unit cannot be properly checked for pressures, etc., on the heating cycle until the heating season has started and room return conditions are in the normal range of 70 degrees dry bulb. However, since the unit was factory operated in both cooling and heating, if you have correct operation in cooling, the heating operation should be satisfactory. Do not run the unit too long in heating, with high summer-time return air temperatures. Return at the beginning of the heating season to check the operation.
- m. With room return air of 70 degrees dry bulb, on the heating cycle, compressor operating pressures should be: suction pressure from 60 to 70 psig, and discharge pressure from 250 to 325 psig.
- n. Check to see that filters are properly positioned, and that they are clean.
- o. Finally, check to see that all panels are on and correctly positioned, and that the unit seems to be operating normally, and that the owner's representative is instructed in unit operation and precautions.

X. MAINTENANCE PROCEDURES

Proper, regularly scheduled maintenance is important to insure the most efficient operation and longest life for your equipment. The following points are to serve as a general guide. Always consult with your maintenance contractor with regard to the specific requirements of your own installation.

- a. Filters — Check the air filters at least once each month. Wash or replace as required.
- b. Bearings — Only sealed bearings are used in the evaporator blower motors. Therefore, bearing oiling is not required.
- c. Paint Finish — Unit is primed and painted giving a durable finish. If paint lifting or peeling occurs, scrape and sand the affected area and touch up with paint obtained from the factory for this purpose.
- d. Water system — The pump should be checked whenever filters are cleaned, to assure that it is operating normally. Clogged coils lead to high pressures and inefficient operation. Abnormal pressures may indicate liming or scaling. If so cleaning is necessary. Condenser coils should be checked **yearly** for liming or clogging.
- e. Refrigerant Pressure — Check at any time unit does not seem to be performing at top efficiency. These should be checked only by a competent service contractor.
- f. Contactor Points — Check contactor points twice a year, to be sure they are not badly burned or pitted as a result of low voltage, lightning strikes, or other electrical difficulties.
- g. Condensate Drains — Always check to see that condensate is draining properly from the unit, whenever you check the filters.
- h. Evaporator Fans — Be alert for any noise that would indicate blower wheels loose, motors or bearings failing.
- i. Condensate Drain Pan — Each 6 months, clean and flush evaporator condensate drain pan.
- j. Belts and Pulleys — Check whenever filters are changed, to make sure belts are tight and pulleys are not loose.

XI. GENERAL SERVICE GUIDE Trouble Diagnosis

- A. SYMPTOM: Compressor will not run — no hum.
Possible Causes:
 1. Disconnect switch open.
 2. Blown fuse(s).
 3. Thermostat not calling.
 4. Open control contacts — defective control.
 5. High or low pressure control open or defective.
 6. Oil pressure control open or defective (larger units with semi-hermetic compressors).
 7. Overload protector tripped or defective.
 8. Defective wiring.
- B. SYMPTOM: Compressor will not start — hums but cycles on overload.
Possible causes:
 1. Low voltage.
 2. Wiring incorrect or loose connections.
 3. Blown fuse.
 4. Compressor motor defective.
 5. Bearings or pistons tight — low oil charge.
 6. Defective compressor motor controller.
- C. SYMPTOM: Compressor starts and runs but cycles on overload protector.
Possible causes:
 1. Low voltage.
 2. Defective overload protector.
 3. Defective high pressure control or lock-out circuit.
 4. Compressor motor partially grounded.
 5. Bearings or pistons tight — low oil pressure.
 6. Improper refrigerant charge.
- D. SYMPTOM: Head pressure too high.
Possible causes:
 1. Refrigerant overcharge.
 2. Air or other non-condensable gases in system.
 3. Dirty or clogged condenser (cool cycle).
 4. Defective fan motor (heat cycle).
 5. Restriction in strainer or drier.
 6. Restriction in discharge or liquid line.
 7. Clogged air filter in unit (heat cycle).
 8. Insufficient water flow (cool cycle).
 9. Loose blowers, pulleys or belts (heat cycle).
 10. Restricted air flow (heat cycle).
 11. Defective expansion valve.
 12. Indoor blower(s) running backwards (heat cycle).
- E. SYMPTOM: Head pressure too low.
Possible causes:
 1. Insufficient refrigerant charge.
 2. Refrigerant leak in system.
 3. Defective compressor.
 4. Insufficient water flow (heat cycle).
 5. Dirty or clogged water coil (heat cycle).
 6. Leaking check valves.
 7. Clogged air filter in unit (cool cycle).
 8. Defective or improperly adjusted expansion valve.
 9. Defective reversing valve.
- F. SYMPTOM: Suction pressure too high.
Possible causes:
 1. Refrigerant overcharge.
 2. Defective compressor discharge valves.
 3. Leaking check valve.
 4. Defective expansion valve.
 5. Expansion valve bulb not secured to suction line.
 6. System overload — too much air or excessive temperatures (cool cycle) — too much water or excessive temperatures (heat cycle).
 7. Defective reversing valve.

- G. SYMPTOM: Suction pressure too low.
Possible causes:
1. Refrigerant undercharge.
 2. Restriction in suction or liquid line.
 3. Defective or improperly adjusted expansion valve.
 4. Check valve not fully opening.
 5. System underload — too little air or low entering temperature (cool cycle) — too little water or low entering temperature (heat cycle).
 6. Clogged air filter in unit (cool cycle).
 7. Loose blower(s), pulley(s) or belts (cool cycle).
 8. Blower(s) running backwards (cool cycle).
- H. SYMPTOM: Compressor short cycles.
Possible causes:
1. Room thermostat malfunction or improper location, improper heat anticipator setting.
 2. Refrigerant undercharge or overcharge and defective high or low pressure control or lock-out circuit.
 3. Cycling on overload protector due to tight bearings, stuck piston, high head pressure, or leaking discharge valves.
 4. Defective expansion valve.
 5. Insufficient water flow (both cycles).
 6. Defective reversing valve.
 7. Poor air distribution causing short circuiting.
- I. SYMPTOM: Running cycle too long or unit operates continuously.
Possible causes:
1. Refrigerant undercharge — possible leak.
 2. Dirty or restricted air coil (cool cycle).
 3. Scaled or otherwise clogged water coil (heat cycle).
 4. Control contacts stuck.
 5. Air or other non-condensable gases in system.
 6. Restriction in suction or liquid line.
 7. Unit too small for application.
 8. Defective compressor.
 9. Insufficient water flow (heat cycle) or insufficient air flow (cool cycle).
 10. Room thermostat malfunction or improper location, incorrect heat anticipator setting.

- J. SYMPTOM: Supply air temperature too high.
Possible causes:
1. Shortage of refrigerant or leak in system (cool cycle).
 2. Restriction in strainer or drier (cool cycle).
 3. Coil plugged with ice or dirt.
 4. Defective compressor.
 5. Restricted air flow (heat cycle).
 6. Restricted water flow (cool cycle).
 7. Maladjusted or defective expansion valve causing high suction superheat and low suction pressure (cool cycle).
 8. Defective reversing valve (cool cycle).
- K. SYMPTOM: Supply air temperature too low.
Possible causes:
1. Compressor not running (heat cycle).
 2. Refrigerant undercharge (heat cycle).
 3. Insufficient water flow or temperature (heat cycle).
 4. Malfunctioning or defective expansion valve (heat cycle).
 5. Defective (or stuck) reversing valve (heat cycle).
 6. Insufficient air flow (cool cycle).
 7. Dirty air filters (cool cycle).
 8. Return air temperature too low.
- L. SYMPTOM: Noisy unit.
Possible causes:
1. Defective compressor.
 2. Blower(s) out of balance.
 3. Fan motor bearings worn.
 4. Tubing rattle.
 5. Loose parts (belts, pulleys, etc.)
 6. Air velocity too high.
- M. SYMPTOM: Liquid line too hot.
Possible causes:
1. Refrigerant undercharge or leak in system.
 2. Excessive head pressure.
- N. SYMPTOM: Liquid line frosted.
Possible cause:
1. Restriction upstream of point of frosting.
- O. SYMPTOM: Suction line frosted.
Possible causes:
1. Malfunctioning or defective expansion valve.
 2. Refrigerant undercharge.
 3. Restriction in suction or liquid line.
 4. Insufficient evaporator air flow or temperature (cool cycle).
 5. Insufficient water flow or temperature (heat cycle).
- P. SYMPTOM: Blower motor not running.
Possible causes:
1. Improper wiring.
 2. Defective motor or controller.
 3. Defective thermostat or control circuit.
 4. Motor off on overload protective device.

XII. TYPICAL WIRING DIAGRAMS

The wiring diagrams on the following pages are typical of those furnished with each unit, mounted on the inside of the unit control panel.

For wiring diagrams of specific units not covered by these typical diagrams, consult our engineering department.

Standard unit diagram numbers are also listed in the parts list, Section XIII.

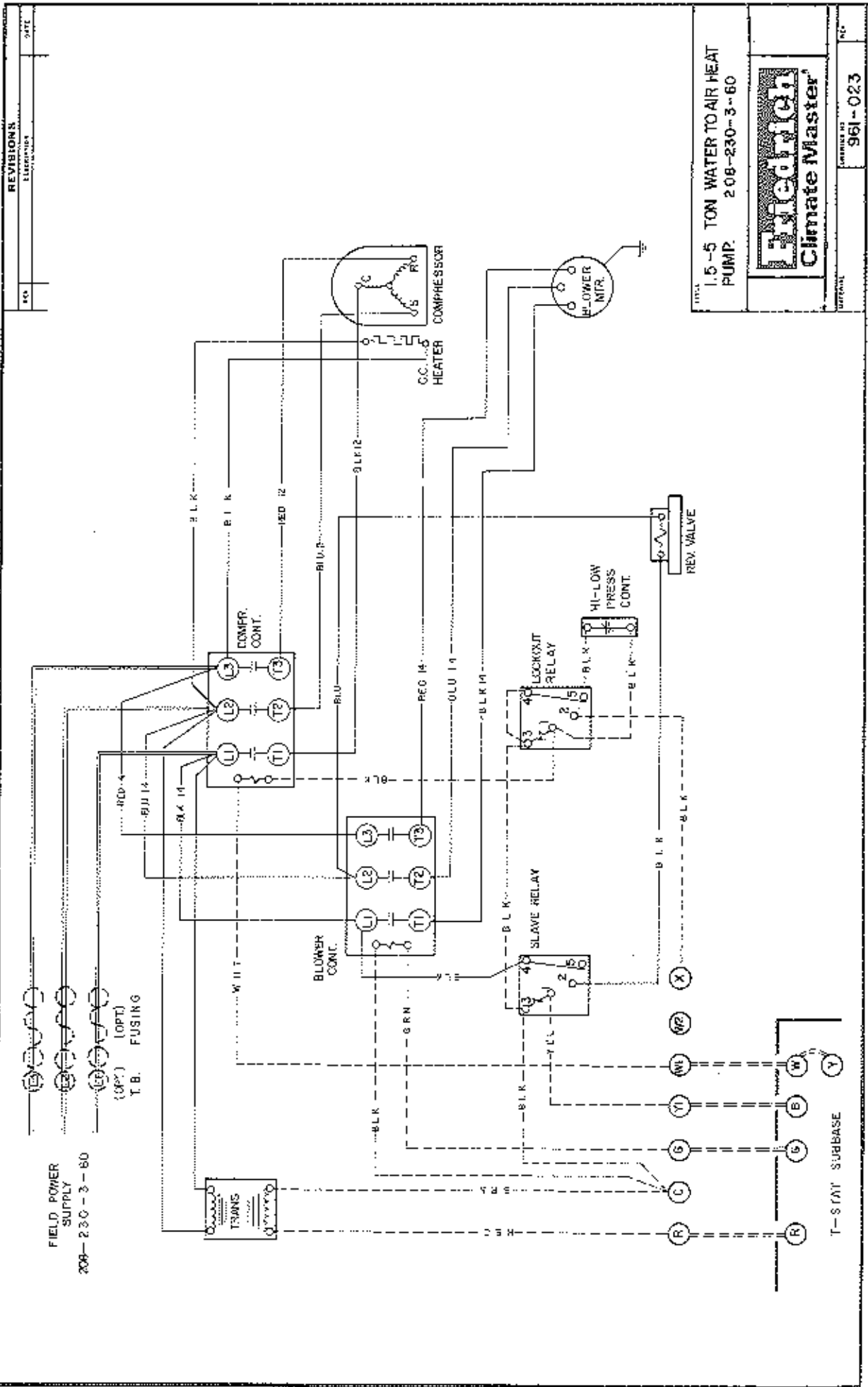

| REV. | REVISIONS | DATE |
|------|-----------|------|
| | | |

1.5-5 TON WATER TO AIR HEAT PUMP. 208-230-3-60

Fredrick
Climate Master

FORMER NO. 961-023

| REV. | DESCRIPTION | DATE |
|------|-------------|------|
| | | |

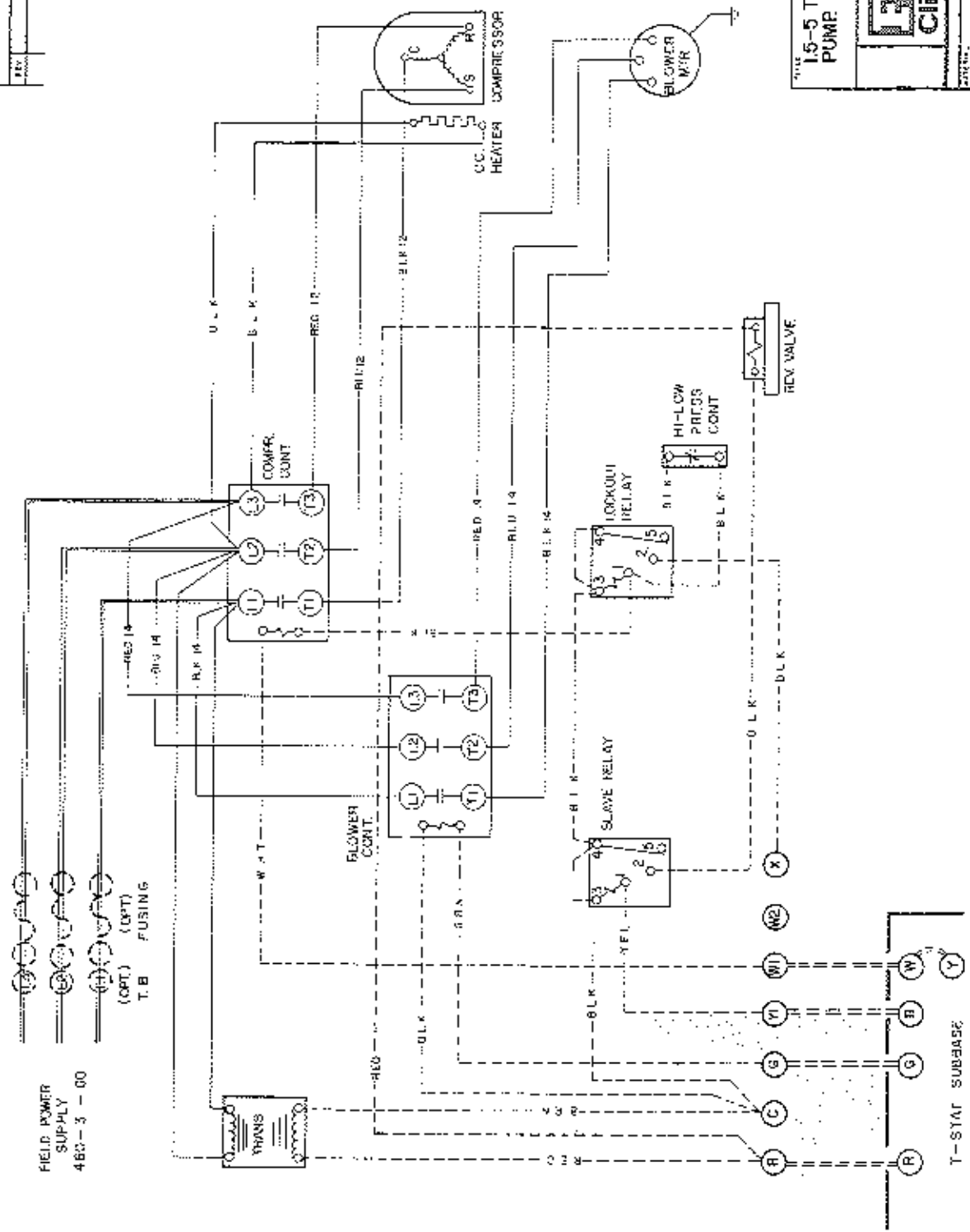

FILE 15-5 TON WATER TO AIR HEAT PUMP 460-3-60



| | |
|------|---------|
| REV. | 961-026 |
|------|---------|

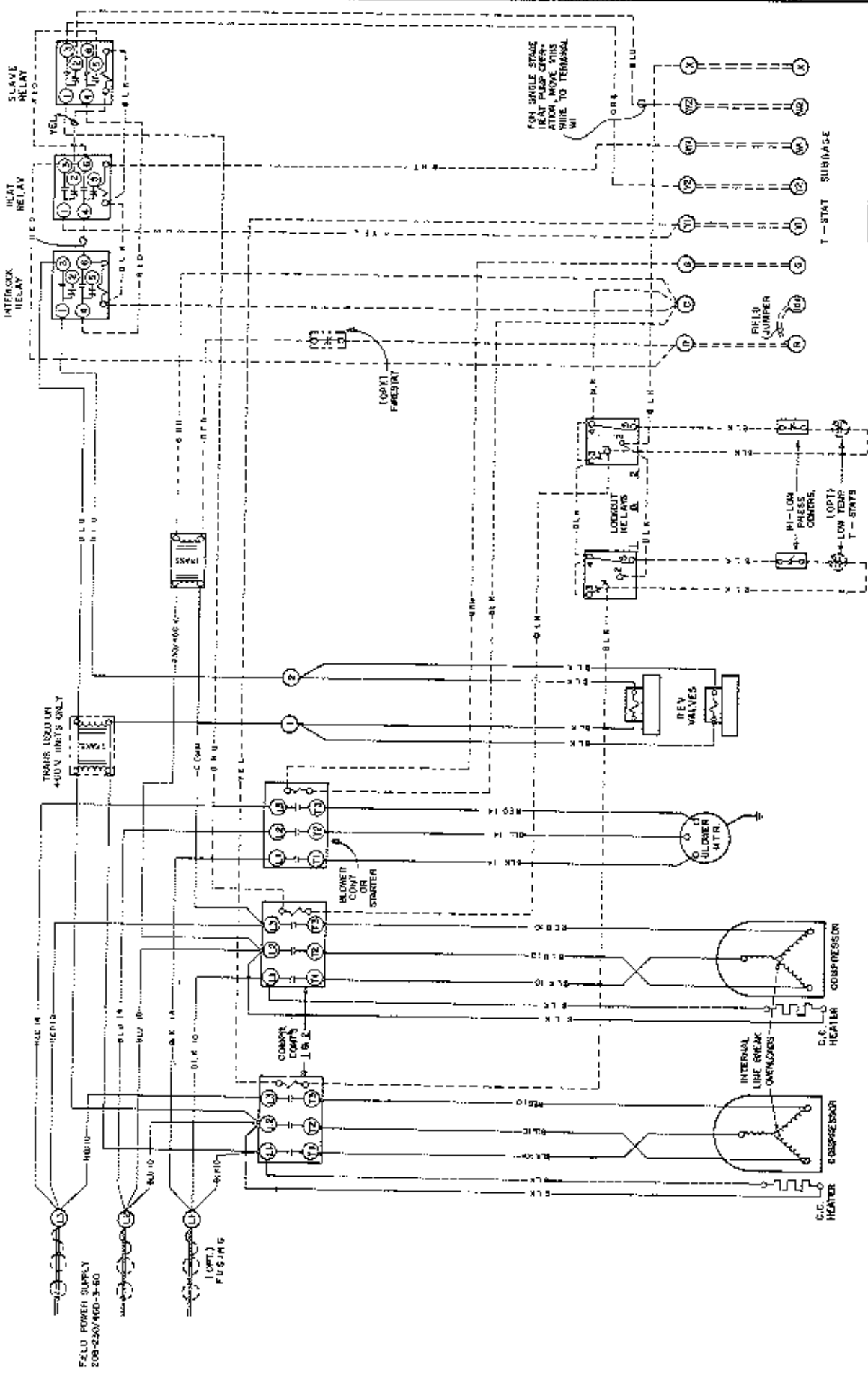

TR 8-10 TON WATER-AIR HEAT PUMP
208-230/460-3-60



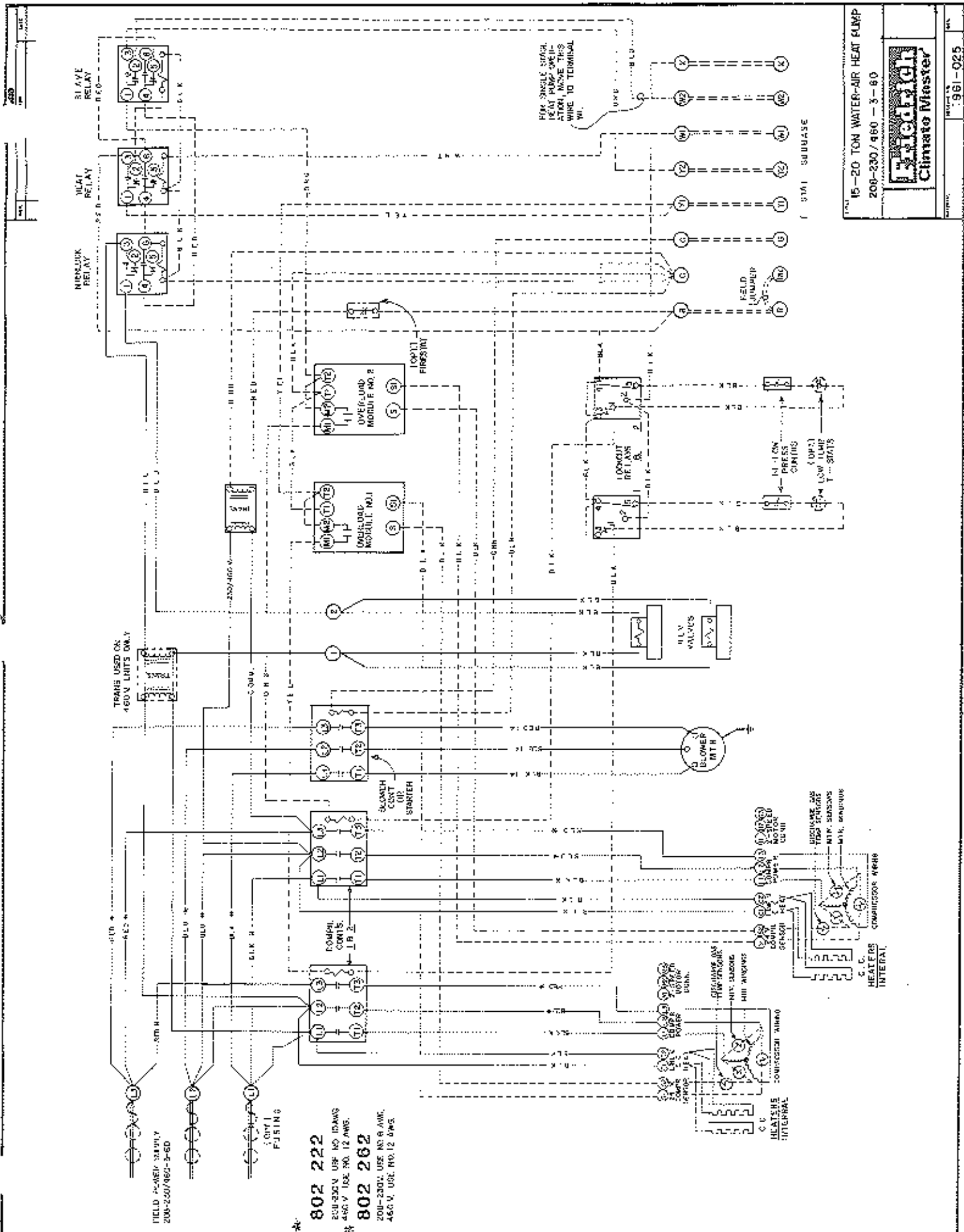

TRANS USED ON
480V LINES ONLY

FIELD 24-480V 3-Ø ONLY
200-230/460-3-Ø

CONTROL
FUSING

802 222

220-240V USE NO. 10 AWS
480V USE NO. 12 AWS

802 262

200-230V USE NO. 6 AWS
480V USE NO. 12 AWS

FOR SINGLE PHASE
HEAT PUMP SYSTEMS,
WIRE TO TERMINAL
W1

STAT SUBBASE

15-20 TON WATER-AIR HEAT PUMP
200-230/460 - 3-Ø



REV. 10/81
961-025

XIII. PARTS LIST — INDEX

Note. The parts lists in this section are typical, for standard units as shown. Many units, however, are equipped with special options and controls. Therefore, always check with the factory, furnishing complete model number, voltage, and 10 digit serial number if you are in doubt about specific part numbers.

Code S = Standard Blower Motor
Code M = Oversize Blower Motor

MOTORS AND DRIVE FOR CODE "M" UNITS

| UNIT MODEL SIZE | 041 | 051 | 071 | 092 | 122 | 142 | 222 | 252 |
|----------------------------|---------|---------|---------|--------|--------|--------|--------|--------|
| UNIT CODE "M" 3/60/200-230 | | | | | | | | |
| MOTOR 1/4 H.P. 30. | 811-34 | | | | | | | |
| MOTOR PULLEY | 550-1 | 551-1 | 551-1 | 551-1 | 551-1 | 551-2 | 551-3 | 551-3 |
| BLOWER PULLEY | 550-135 | 550-107 | 550-135 | 550-24 | 550-34 | 550-24 | 550-52 | 550-52 |
| MOTOR 1 H.P. 30. | | 811-81 | | | | | | |
| MOTOR 1 1/2 H.P. 30. | | | 511-12 | | | | | |
| MOTOR 2 H.P. 30. | | | | 811-16 | 811-15 | | | |
| MOTOR 3 H.P. 30. | | | | | | 511-53 | | |
| MOTOR 5 H.P. 30. | | | | | | | 811-9 | 811-9 |
| UNIT CODE "M" 460 v. | | | | | | | | |
| MOTOR 1 H.P. 460 v. | 811-81 | 511-81 | | | | | | |
| MOTOR 1 1/2 H.P. 460 v. | | | 511-12 | | | | | |
| MOTOR 2 H.P. 460 v. | | | | 811-15 | 811-16 | | | |
| MOTOR 3 H.P. 460 v. | | | | | | 811-53 | | |
| MOTOR 5 H.P. 460 v. | | | | | | | 811-9 | 811-9 |

REPLACEMENT PARTS — ROOFTOP WATER TO AIR HEAT PUMPS

3-60-208-230 V.

| UNIT MODEL SIZE | 4 | 5 | 7 | 9 | 12 | 14 | 22 | 28 |
|----------------------------|-----------------|-----------------|-----------------|-------------------|-------------------|-------------------|-----------------|-----------------|
| COMPRESSOR #1 | 800-248 | 800-238 | 800-240 | 800-248 | 800-281 | 800-240 | 800-257 | 800-256 |
| CRANKCASE HEATER #1 | 864-27 | w/Comp. | w/Comp. | 864-27 | w/Comp. | w/Comp. | w/Comp. | w/Comp. |
| COMPRESSOR #2 | — | — | — | 800-248 | 800-281 | 800-240 | 800-257 | 800-256 |
| CRANKCASE HEATER #2 | — | — | — | 864-27 | NOTE 3 | NOTE 3 | NOTE 3 | NOTE 3 |
| REF. WATER HEAT EXCH. #1 | 512-134 | 512-134 | 512-160 | 512-121 | 512-121 | 512-170 | 512-170 | 512-170 |
| REF. WATER HEAT EXCH. #2 | — | — | — | 512-121 | 512-121 | — | — | — |
| EVAPORATOR DISTRIBUTOR | 724-148 w/Evap. | 724-148 w/Evap. | 724-148 w/Evap. | 724-144 564-87(2) | 724-145 564-88(2) | 724-145 564-88(2) | 724-150 w/Evap. | 724-150 w/Evap. |
| EXPANSION VALVE #1 | 564-57 | 564-59 | 564-60 | 564-57 | 564-59 | 564-59 | 564-60 | 564-62 |
| EXPANSION VALVE #2 | — | — | — | 564-57 | 564-59 | 564-59 | 564-60 | 564-62 |
| REVERSING VALVE #1 | 564-10 | 564-10 | 554-52 | 564-10 | 564-10 | 564-52 | 564-11 | 564-11 |
| REVERSING VALVE #2 | — | — | — | 564-10 | 564-10 | 564-52 | 564-11 | 564-11 |
| REVERSING VALVE COIL | 874-14 | 874-14 | 874-14 | 874-14 | 874-14 | 874-14 | 874-14 | 874-14 |
| DRIER | 521-26 | 521-26 | 521-26 | 521-26(2) | 521-26(2) | 521-26(2) | 521-26(2) | 521-26(2) |
| SIGHT GLASS | 548-5 | 548-5 | 548-5 | 548-5(2) | 548-5(2) | 548-5(2) | 548-5(2) | 548-5(2) |
| ACCUMULATOR | 522-6 | 522-6 | 522-6 | 522-6(2) | 522-6(2) | 522-6(2) | 522-9(2) | 522-10(2) |
| HIGH PRESSURE CONTROL | 844-21 | 844-21 | 844-21 | 844-21(2) | 844-21(2) | 844-21(2) | 844-23(2) | 844-26(2) |
| LOW PRESSURE CONTROL | 844-23 | 844-23 | 844-23 | 844-23(2) | 844-23(2) | 844-23(2) | — | — |
| BLOWER | 515-38 | 515-38 | 515-38 | 515-19(2) | 515-19(2) | 515-19(2) | 515-15(2) | 515-15(2) |
| BLOWER SHAFT | 202-22 | 202-22 | 202-22 | 202-18 | 202-18 | 202-18 | 202-24 | 202-24 |
| BLOWER BEARINGS | 561-14(2) | 561-14(2) | 561-14(2) | 561-15(2) | 561-15(2) | 561-15(2) | 561-15(2) | 561-15(2) |
| BLOWER PULLEY | 550-30 | 550-134 | 550-36 | 550-85 | 550-95 | 550-125 | 550-54 | 550-54 |
| MOTOR CODE S. | 811-3 | 811-34 | 811-81 | 811-12 | 811-12 | 811-16 | 811-53 | 811-53 |
| MOTOR PULLEY | 551-1 | 551-1 | 551-1 | 551-1 | 551-1 | 551-1 | 551-2 | 551-2 |
| BELT | AS REQ'D. | AS REQ'D. | AS REQ'D. | AS REQ'D. | AS REQ'D. | AS REQ'D. | AS REQ'D. | AS REQ'D. |
| FILTER—AIR | 333-65 | 333-65 | 333-65 | 333-4(4) | 333-4(4) | 333-4(4) | 333-5(5) | 333-5(5) |
| SERVICE VALVE | 564-233 | 564-233 | 564-233 | 564-233 | 564-233 | 564-233 | 564-233 | 564-233 |
| CONTROL PANEL PARTS | | | | | | | | |
| CONTACTOR #1 COMP. | 841-39 | 841-39 | 841-39 | 841-39 | 841-39 | 841-39 | 841-40 | 841-40 |
| CONTACTOR #2 COMP. | — | — | — | 841-39 | 841-39 | 841-39 | 841-40 | 841-40 |
| TRANSFORMER 24 VOLT | 846-56 | 846-56 | 846-56 | 846-61 | 846-61 | 846-51 | 846-61 | 846-61 |
| TRANSFORMER 230 VOLT | — | — | — | — | — | — | — | — |
| CONTACTOR BLOWER Standard | 841-21 | 841-21 | 841-21 | 841-21 | 841-21 | 841-21 | 841-27 | 841-27 |
| CONTACTOR BLOWER Oversize | 841-21 | 841-21 | 841-21 | 841-21 | 841-21 | 841-27 | 841-27 | 841-27 |
| LOCKOUT RELAY | 821-114 | 821-114 | 821-114 | 821-114(2) | 821-114(2) | 821-114(2) | 821-114(2) | 821-114(2) |
| SLAVE RELAY | 821-79 | 821-79 | 821-79 | 821-54 | 821-84 | 821-84 | 821-84 | 821-84 |
| HEAT RELAY | — | — | — | 821-84 | 821-84 | 821-84 | 821-84 | 821-84 |
| INTERLOCK RELAY | — | — | — | 821-84 | 821-84 | 821-84 | 821-84 | 821-84 |
| COMPRESSOR OVERLOAD MODULE | — | — | — | — | — | — | 831-150(2) | 831-150(2) |
| WIRING DIAGRAM NO. | 961-023 | 961-023 | 961-023 | 961-024 | 961-024 | 961-024 | 961-025 | 961-025 |

REPLACEMENT PARTS — ROOFTOP WATER TO AIR HEAT PUMPS

3-60-460 V.

| UNIT MODEL SIZE | 4 | 5 | 7 | 9 | 12 | 14 | 22 | 26 |
|----------------------------|-----------|-----------|-----------|------------|------------|------------|------------|------------|
| COMPRESSOR #1 | 800-256 | 800-278 | 800-274 | 800-256 | 800-282 | 800-274 | 800-264 | 800-267 |
| CRANKCASE HEATER #1 | 864-30 | w/Comp. | w/Comp. | 864-30 | w/Comp. | w/Comp. | w/Comp. | w/Comp. |
| COMPRESSOR #2 | — | — | — | 800-256 | 800-282 | 800-274 | 800-264 | 800-267 |
| CRANKCASE HEATER #2 | — | — | — | 864-30 | w/Comp. | w/Comp. | w/Comp. | w/Comp. |
| REF./WATER HEAT EXCH. #1 | 512-134 | 512-134 | 512-180 | 512-121 | 512-121 | 512-170 | 512-170 | 512-170 |
| REF./WATER HEAT EXCH. #2 | — | — | — | 512-121 | 512-121 | — | — | — |
| EVAP. COIL | 724-148 | 724-148 | 724-148 | 724-144 | 724-145 | 724-145 | 724-150 | 724-150 |
| DISTRIBUTOR | w/Evap. | w/Evap. | w/Evap. | 564-57(2) | 564-58(2) | 564-58(2) | w/Evap. | w/Evap. |
| EXPANSION VALVE #1 | 564-57 | 564-59 | 564-60 | 564-57 | 564-59 | 564-59 | 564-60 | 564-62 |
| EXPANSION VALVE #2 | — | — | — | 564-57 | 564-59 | 564-59 | 564-60 | 564-62 |
| REVERSING VALVE #1 | 564-10 | 564-10 | 564-52 | 564-10 | 564-10 | 564-52 | 564-52 | 564-11 |
| REVERSING VALVE #2 | — | — | — | 564-10 | 564-10 | 564-52 | 564-52 | 564-11 |
| REVERSING VALVE COIL | 874-15 | 874-15 | 874-15 | 874-14 | 874-14 | 874-14 | 874-14 | 874-14 |
| DRIER | 521-26 | 521-26 | 521-26 | 521-25(2) | 521-25(2) | 521-25(2) | 521-26(2) | 521-25(2) |
| SIGHT GLASS | 548-5 | 548-5 | 548-5 | 548-5(2) | 548-5(2) | 548-5(2) | 548-5(2) | 548-5(2) |
| ACCUMULATOR | 522-6 | 522-6 | 522-6 | 522-5(2) | 522-5(2) | 522-5(2) | 522-9(2) | 522-10(2) |
| HIGH PRESSURE CONTROL | 844-21 | 844-21 | 844-21 | 844-21(2) | 844-21(2) | 844-21(2) | 844-25(2) | 844-25(2) |
| LOW PRESSURE CONTROL | 844-23 | 844-23 | 844-23 | 844-23(2) | 844-23(2) | 844-23(2) | DUAL | DUAL |
| BLOWER | 515-36 | 515-36 | 515-36 | 515-19(2) | 515-19(2) | 515-19(2) | 515-15(2) | 515-15(2) |
| BLOWER SHAFT | 202-22 | 202-22 | 202-22 | 202-18 | 202-18 | 202-18 | 202-24 | 202-24 |
| BLOWER BEARINGS | 561-14(2) | 561-14(2) | 561-14(2) | 561-15(3) | 561-15(3) | 561-15(3) | 561-15(3) | 561-15(3) |
| BLOWER PULLEY | 550-30 | 550-134 | 550-35 | 550-95 | 550-95 | 550-125 | 550-54 | 550-54 |
| MOTOR CODE S. | 811-39 | 811-81 | 811-81 | 811-12 | 811-12 | 811-16 | 811-53 | 811-53 |
| MOTOR PULLEY | 551-1 | 551-1 | 551-1 | 551-1 | 551-1 | 551-1 | 551-2 | 551-2 |
| BELT | AS REQ'D. | AS REQ'D. | AS REQ'D. | AS REQ'D. | AS REQ'D. | AS REQ'D. | AS REQ'D. | AS REQ'D. |
| FILTER—AIR | 333-65 | 333-65 | 333-65 | 333-4(4) | 333-4(4) | 333-4(4) | 333-5(5) | 333-5(5) |
| SERVICE VALVE—3 | 564-233 | 564-233 | 564-233 | 564-233 | 564-233 | 564-233 | 564-233 | 564-233 |
| SHRADER VALVE—3 | 564-241 | 564-241 | 564-241 | 564-241 | 564-241 | 564-241 | 564-241 | 564-241 |
| VALVE CORE | 609-2 | 609-2 | 609-2 | 609-2 | 609-2 | 609-2 | 609-2 | 609-2 |
| CONTROL PANEL PARTS | | | | | | | | |
| CONTACTOR #1 COMP. | 841-39 | 841-39 | 841-39 | 841-39 | 841-39 | 841-39 | 841-39 | 841-39 |
| CONTACTOR #2 COMP. | — | — | — | 841-39 | 841-39 | 841-39 | 841-39 | 841-39 |
| TRANSFORMER 24V | 846-56 | 846-56 | 846-56 | 846-61 | 846-61 | 846-61 | 846-61 | 846-61 |
| TRANSFORMER 230V | — | — | — | 846-37 | 846-37 | 846-37 | 846-37 | 846-37 |
| CONTACTOR BLOWER STD. | 841-21 | 841-21 | 841-21 | 841-21 | 841-21 | 841-21 | 841-27 | 841-27 |
| CONTACTOR BLOWER Oversize | 841-21 | 841-21 | 841-21 | 841-21 | 841-21 | 841-27 | 841-27 | 841-27 |
| LOCKOUT RELAY | 821-114 | 821-114 | 821-114 | 821-114(2) | 821-114(2) | 821-114(2) | 821-114(2) | 821-114(2) |
| SLAVE RELAY | 821-79 | 821-79 | 821-79 | 821-84 | 821-84 | 821-84 | 821-84 | 821-84 |
| HEAT RELAY | — | — | — | 821-84 | 821-84 | 821-84 | 821-84 | 821-84 |
| INTERLOCK RELAY | — | — | — | 821-84 | 821-84 | 821-84 | 821-84 | 821-84 |
| COMPRESSOR OVERLOAD MODULE | — | — | — | — | — | — | 831-150(2) | 831-150(2) |
| WIRING DIAGRAM NO. | 961-026 | 961-026 | 961-026 | 961-024 | 961-024 | 961-024 | 961-025 | 961-025 |

ClimateMaster

A COMBINATION OF CHP CORP. AND
FRIEDRICH™ CLIMATE MASTER, INC.

2007 Beechgrove Place
Utica, N.Y. 13501
315/724-7111
TWX 510-600-7973