



COMMERCIAL
TRANQUILITY[®] 18 (SR) VERSATILE SINGLE-STAGE SERIES
PRODUCT CATALOG

Part#: LC3001 | Revised: January 31, 2025

Models: SR 006-060
60 Hz - R-454B

Table of Contents

Models:
SR
006-060

3	Introduction	49	Antifreeze Correction Table
5	Features, Options, and Accessories	51	Correction Tables: Water Pressure Drop Adder for Options
7	iGate 2 Communicating Controls Powered by CXM2 Communicating Controls	53	Blower Performance
8	iGate 2 Communicating Controls Powered by DXM2.5 Advanced Communicating Controls	70	Waterside Economizers Performance
9	iGate 2 Communicating (AWC) Thermostat	71	Physical Data
10	myUplink: Web and Mobile Interface	73	Standard Dimensional Data
11	Selection Procedure	77	Horizontal Cabinet Corner Weights
13	Model Nomenclature	81	Horizontal Service Access
14	Performance Data: ASHRAE/AHRI/ISO 13256-1	84	Vertical Service Access
16	Performance Data: Selection Notes	85	Minimum Installation Area
17	Performance Data	86	Electrical Data
45	CV EC Motor Limits	93	Hot Gas Reheat
46	Standard Correction Tables	95	Hot Gas Reheat Sequence of Operations
47	Hybrid Correction Tables	97	Engineering Specifications
48	WSE Correction Tables	108	Revision History

THE TRANQUILITY® 18 (SR) VERSATILE SERIES

The Tranquility 18 (SR) Versatile Series raises the bar for water-source heat pump features and application flexibility. Not only does the Tranquility SR exceed ASHRAE 90.1 efficiency standards, but it also uses R-454B low Global Warming Potential (GWP) refrigerant, making it an environmentally-friendly space conditioning product solution. Tranquility SR is eligible for LEED® (Leadership in Energy and Environmental Design) points due to its innovative and environmentally-conscious design. The Tranquility SR stands out as having the most comprehensive set of options contained in a compact footprint making it the value leader in water source heat pump products.

Available in sizes from ½ ton (1.8 kW) through 5 tons (17.6 kW) with multiple cabinet options (vertical upflow and horizontal), the Tranquility SR offers flexibility for most any installation. The Tranquility SR has an extended range refrigerant circuit, capable of geothermal ground loop applications (with optional extended range insulation) as well as boiler-tower water loop applications. Standard features include: scroll compressor, microprocessor controls, galvanized-steel cabinet, polymer drain pan, and sound-absorbing air handler insulation are just some of the features of the Tranquility SR.

Recent EPA mandates require an industry transition to low-GWP refrigerants, such as R-454B which is a gas that is classified as having low-toxicity, low-flammability rating. Due to these characteristics, R-454B systems charged with over 62 ounces of refrigerant must contain an integrated Refrigerant Detection System (RDS). In the unlikely event of a system-refrigerant leak, the RDS shuts down compressor operation and runs the unit blower motor to disperse any concentration of leaked refrigerant in compliance with UL 60335-2-40 safety standards. For Tranquility SR products, only the 5 ton size (060) is required to have the RDS and the feature is optional on all other sizes.

ClimateMaster's double isolation compressor mounting system makes the Tranquility SR one of the quietest units on the market. Compressors are mounted on specially engineered sound-tested EPDM grommets to a heavy-gauge mounting plate, which is further isolated from the cabinet base with EPDM grommets for maximized vibration and sound attenuation. The easy access control box and large access panels make installing and maintaining the unit easier than other water-source heat pumps on the market.

Options such as Hot Gas Reheat, DDC controls, hybrid hydronic heating, tin-plated air coil, and high efficiency MERV-rated air filters allow for customized design solutions. Cupro-nickel water-coils and ClimateMaster's industry leading sound attenuation UltraQuiet package are options that make a great unit even better.

iGate® 2 technology provides technicians an interface into the operation of the system in real time without the need for hard tooling. On-board advanced controls communicate the key operating system temperatures enabling technicians to startup, commission, and service the equipment remotely by smart phone or website via the cloud. Communication can also be done at the unit via a communicating thermostat or handheld service tool. Not only does iGate 2 monitor current performance, it also allows the functionality to make system adjustments and captures operating conditions at time of fault. All this information is displayed in an easy to read format maximizing the usability of the experience.

Hybrid hydronic heating combines the benefits of water-source heat pumps and hydronic fan coils into one system. In cooling mode the system performs as normal using a compressor and refrigerant coil. In the heating mode the system uses a hydronic coil for heating. By design, the system reduces compressor cycling, consumes less power, eliminates compressor noise at the unit in heating mode, and does not require a reversing valve to be used. Hybrid systems are an ideal fit for applications where hot water is provided as a domestic utility or can be efficiently generated.

Waterside Economizers (WSE) enable the use of the building's water loop to provide "free" cooling when the fluid temperature is at or below the economizer setpoint, typically in the range of 45°F (7°C) to 50°F (7°C). When space cooling is required, air is drawn through the economizer coil and the compressor is disabled, reducing energy use.

The Hot Gas Reheat (HGRH) system ensures efficient dehumidification while maintaining comfortable space conditions, making it a cost-effective solution for environments with strict humidity requirements. In operation, return air from the space is first conditioned by the air-to-refrigerant coil. To prevent over-cooling, the air is then reheated to a neutral temperature using the hot gas reheat coil. The system's moisture removal effectiveness is determined by its latent capacity rating. When the desired space temperature is reached but the humidity is not, the humidistat signals the WSHP system to activate reheat mode. This process directs high-pressure refrigerant gas from the compressor through the reheat coil. As a result, it enables effective dehumidification without compromising comfort.

The Tranquility 18 (SR) Versatile Series water-source heat pumps are designed to meet the challenges of today's HVAC demands with one of the most innovative products available on the market.

FEATURES

- Sizes 006 (½ ton, 1.8 kW) through 060 (5 tons, 17.6 kW)
- Exceeds ASHRAE 90.1 efficiency standards
- Environmentally-friendly R-454B low-GWP refrigerant
- Refrigerant Detection System (RDS) (mandatory on size 060, optional feature for sizes 006-048)
- Coaxial heat exchanger
- Galvanized-steel cabinet construction
- Sound-absorbing glass-fiber insulation
- Unique double-isolation compressor mounting for quiet operation
- Insulated divider and separate compressor/air-handler compartments
- TXV metering device
- Microprocessor controls with on-board fuse and emergency shutdown
- Field-convertible discharge-air arrangement (horizontal configurations only)
- PSC three-speed fan motor (two-speed for 575V)
- Unit Performance Sentinel performance-monitoring system
- Eight standard safety features
- Non-corrosive polymer drain pan
- External connecting port on front-left corner post facilitates service tool connectivity, thereby reducing startup, commissioning, and service time
- CXM2 Communicating Controls:
 - Multiple communication pathways for unit access and diagnosis:
 - Cloud-based remote monitoring via iGate 2 Communicating (AWC) Thermostat
 - Connect directly to the system with a handheld service tool
 - Provides real-time unit operating conditions
 - Reduces startup, commissioning, and service time by providing key system temperatures electronically
 - Captures operating conditions in the event of a safety shutdown

OPTIONS

- High efficiency EC blower motors:
 - Intelligent Constant Volume (CV) EC motors for ultimate airflow control
 - Entry-level Constant Torque (CT) EC motors provide efficiency at a value
- DXM2.5 Advanced Communicating Controls:
 - Includes all of the CXM2 features
 - Dial in desired airflows for CV EC blower motors
 - Controls operation of domestic Hot Water Generator (HWG)
- Hot Gas Reheat for enhanced climate control and humidity management
- Hybrid hydronic heating
- BACnet, Modbus, and Johnson Controls N2 compatibility options for Building Management Systems (BMS)
- Corrosion-resistant cupro-nickel water-heat exchanger
- UltraQuiet sound-attenuation package
- Tin-plated air coils for added protection from formicary corrosion
- Domestic Hot Water Generator (HWG)
- Internally-mounted water pump for single-pipe systems
- Autoflow regulators that limit water flow, preventing system overpumping
- Motorized water valves prevent water flow when not in operation, increasing system-pumping efficiency
- Easy-to-clean rust-prohibitive stainless-steel drain pans
- Integrated power disconnect
- Extended-range insulation for geothermal applications
- Waterside Economizers for energy savings

ACCESSORIES

- iGate 2 Communicating (AWC) Thermostat with color touchscreen
- Wide variety of thermostat options to meet your application needs
- Braided-hose kits in various lengths with optional water valve, PT plugs, blowdown valve, flow regulator, and strainer
- Externally-mounted manual and motorized water valves
- 1-inch Merv 8 filter
- 2-inch Merv 8 or 13 filters
- Aesthetically-pleasing wall sensors for connection to BMS (MPC) controls

iGate 2 Communicating Controls Powered by CXM2 Communicating Controls

Models:
SR
006-060

iGATE 2 COMMUNICATION – CLOUD CONNECTED, WEB-ENABLED INFORMATION GATEWAY TO MONITOR, CONTROL, AND DIAGNOSE YOUR SYSTEM

iGate 2 Communication – Cloud connected, web-enabled information gateway to monitor, control, and diagnose your system.

The Tranquility SR is equipped with industry-first, iGate 2 communication information gateway that allows users to interact with their water-source system in easy to read clear language.

Monitor/Configure – Installers can configure from the myUplink PRO website, mobile app, AWC Thermostat, or diagnostic tool, including: Unit family, size, accessory configuration, and demand reduction (optional, to limit unit operation during peak times). Users can look up the current system status: temperature sensor readings and operational status of the blower.

Precise Control – The new CXM2 enables intelligent, two-way communication between the CXM2 and smart components like the AWC Thermostat and diagnostic tool. CXM2 Communicating Controls uses information received from the temperature sensors to precisely control operation to deliver high efficiency, reliability and increased comfort.

Diagnostics – iGate 2 takes diagnosing water source heat pump units to a next level of simplicity, by providing a dashboard of system and fault information, in clear language, on the AWC Thermostat, handheld service tool and the web portal/mobile app on the internet.

iGate 2 Service Warnings notify the homeowner and contractor of a fault and displays fault descriptions by app notifications/email with possible causes. Additionally, the current system status can be viewed graphically on the web portal and mobile app.

In iGate 2 Service Mode, the service personnel can access fault description, possible causes and most importantly, the conditions (temp, flow, i/o conditions, configuration) at the time of the fault. Manual Operation mode allows the service personnel to manually command operation for any of the thermostat outputs, blower speed, to help troubleshoot specific components. This operation can either be conducted at the unit with a communicating thermostat/diagnostic tool or remotely with mobile app/website when the AWC Thermostat controls are used.

With an iGate 2 communicating system, users and contractors have a web-enabled gateway to system information never before available and exclusive to ClimateMaster products.

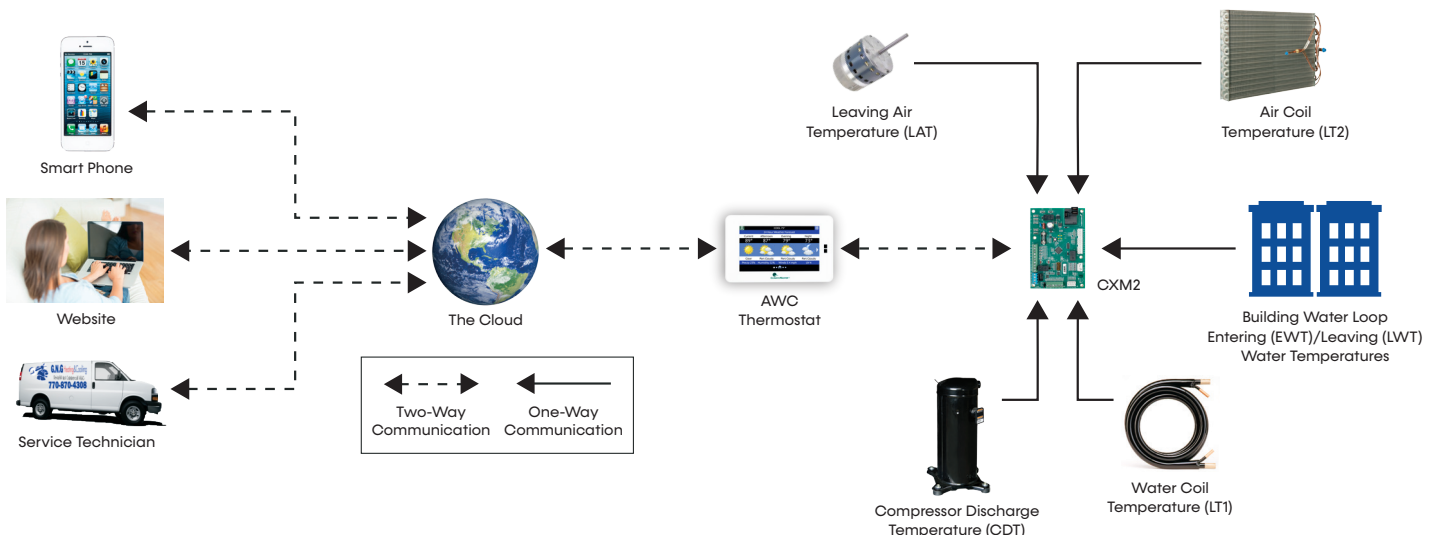

ClimateMaster works continually to improve its products. As a result, the design and specifications of each product at the time of order may be changed without notice and may not be as described herein. Please contact ClimateMaster's Customer Service Department at 800-299-9747 for specific information on the current design and specifications. Statements and other information contained herein are not express warranties and do not form the basis of any bargain between the parties, but are merely ClimateMaster's opinion or commendation of its products. The latest version of this document is available at www.climatemaster.com. Engineered and assembled in the USA. © ClimateMaster, Inc. All Rights Reserved 2024

iGate 2 Communicating Controls Powered by DXM2.5 Advanced Communicating Controls

Models:
SR
006-060

iGATE 2 COMMUNICATION – CLOUD CONNECTED, WEB-ENABLED INFORMATION GATEWAY TO MONITOR, CONTROL, AND DIAGNOSE YOUR SYSTEM

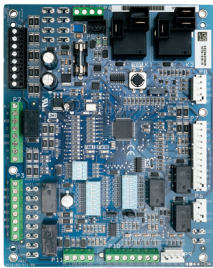

The Tranquility SR is equipped with industry-first, iGate 2 communication information gateway that allows users to interact with their water-source system in easy to read clear language AND delivers improved reliability and efficiency by precisely

controlling smart components.

Monitor/Configure – Installers can configure from the myUplink PRO website, mobile app, AWC Thermostat, or diagnostic tool, including: airflow, unit family, size, accessory configuration, and demand reduction (optional, to limit unit operation during peak times). Users can look up the current system status: temperature sensor readings and operational status of the blower.

Precise Control – The DXM2.5 enables intelligent, two-way communication between the DXM2.5 and smart components like the communicating thermostat/diagnostic tool and constant volume CV EC blower motor. DXM2.5 Advanced Communicating Controls uses information received from the smart components and temperature sensors to precisely control operation of the variable speed CV EC fan to deliver higher efficiency, reliability and increased comfort.

Diagnostics – iGate 2 takes diagnosing water source heat pump units to a next level of simplicity, by providing a dashboard of system and fault information, in clear language, on the AWC Thermostat, handheld service tool and the web portal/mobile app on the internet.

iGate 2 Service Warnings notify the homeowner and contractor of a fault and displays fault descriptions by app notifications and email with possible causes. Additionally, the current system status can be viewed graphically on the web portal and mobile app.

In iGate 2 Service Mode, the service personnel can access fault description, possible causes and most importantly, the conditions (temp, flow, i/o conditions, configuration) at the time of the fault. Manual Operation mode allows the service personnel to manually command operation for any of the thermostat outputs, blower speed, to help troubleshoot specific components. This operation can either be conducted at the unit with a diagnostic tool or remotely with mobile app/website when the AWC Thermostat controls are used.

With an iGate 2 communicating system, users and contractors have a web-enabled gateway to system information never before available and exclusive to ClimateMaster products.

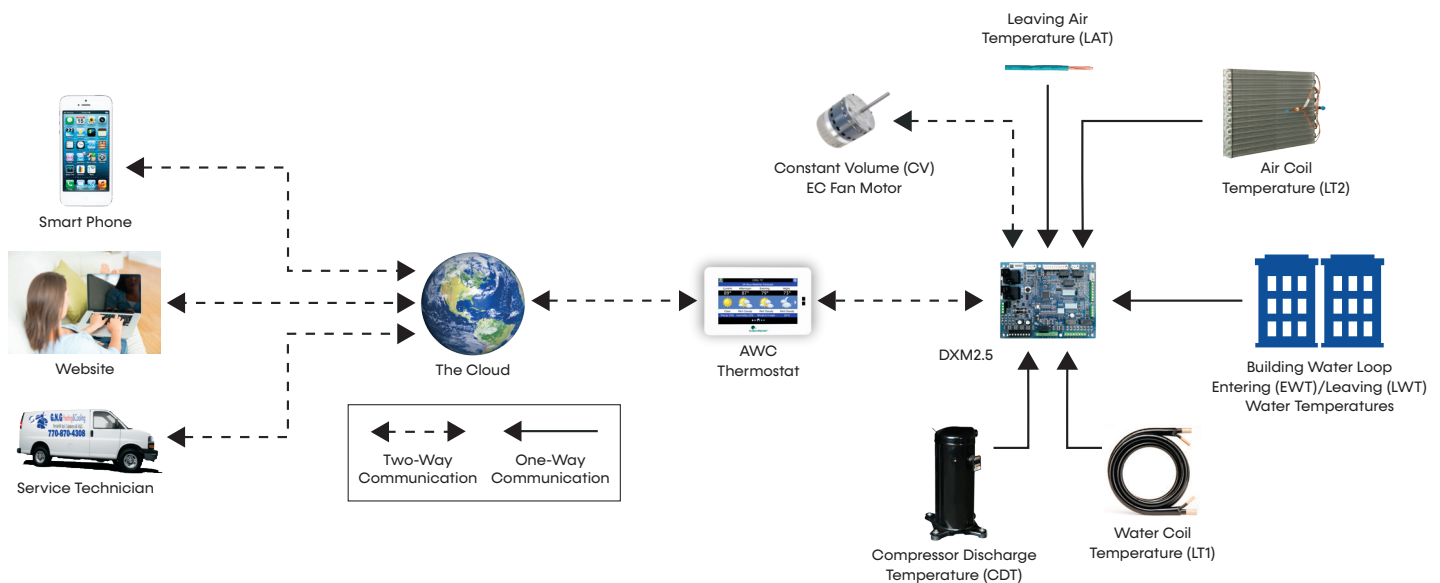

ClimateMaster works continually to improve its products. As a result, the design and specifications of each product at the time of order may be changed without notice and may not be as described herein. Please contact ClimateMaster's Customer Service Department at 800-299-9747 for specific information on the current design and specifications. Statements and other information contained herein are not express warranties and do not form the basis of any bargain between the parties, but are merely ClimateMaster's opinion or commendation of its products. The latest version of this document is available at www.climatemaster.com. Engineered and assembled in the USA. © ClimateMaster, Inc. All Rights Reserved 2024

iGate 2 Communicating (AWC) Thermostat

Models:
SR
006-060

iGATE 2 COMMUNICATION – CLOUD CONNECTED, WEB-ENABLED INFORMATION GATEWAY TO MONITOR, CONTROL, AND DIAGNOSE YOUR SYSTEM

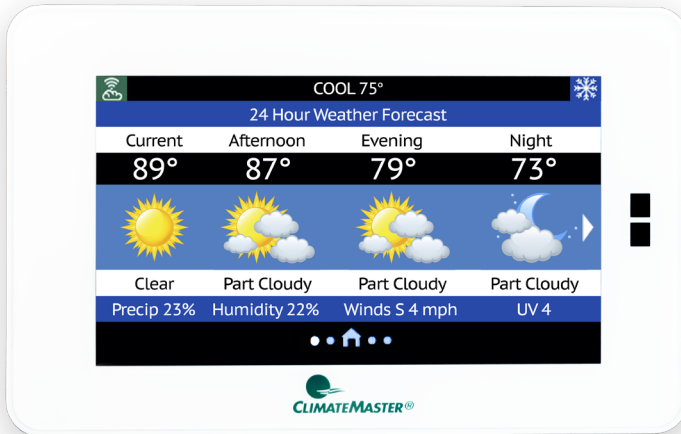

The iGate 2 Communicating (AWC) Thermostat is innovating the future of comfort technology, one building at a time. The inspired design of the touch screen interface allows you to see real-time data for the efficiency and health of your system, with early warnings for potential system faults. The cloud based information gateway allows technicians to remotely diagnose system issues before occupants even know there is a problem. Control and monitor the system in your home or business from anywhere in the world with an easy to use app on your phone.

Features with Efficiency in Mind



Touchscreen Interface

A brilliantly customizable touchscreen monitor for simple control.



Seamless Integration

Between your AWC Thermostat and comfort system.



(Mobile) Remote System Control

Control temperature and schedule from anywhere in the world.



Early Fault Warnings

Alerts the building owner and the contractor of potential system faults in the future.



Remote Diagnostics

Enable the contractor to remotely diagnose system issues, adjust system settings, and reset faults.



Real-Time Operations Data and System Schematics

Access simply via the myUplink Pro Account and web portal to view system diagrams with current operating temperatures.



Revenue Stream

HVAC professionals can offer owners service contracts with remote monitoring and diagnostic capabilities without the large expense of a building management system.



ClimateMaster works continually to improve its products. As a result, the design and specifications of each product at the time of order may be changed without notice and may not be as described herein. Please contact ClimateMaster's Customer Service Department at 800-299-9747 for specific information on the current design and specifications. Statements and other information contained herein are not express warranties and do not form the basis of any bargain between the parties, but are merely ClimateMaster's opinion or commendation of its products. The latest version of this document is available at www.climatemaster.com. Engineered and assembled in the USA. © ClimateMaster, Inc. All Rights Reserved 2024

HVAC Professional | User Experience

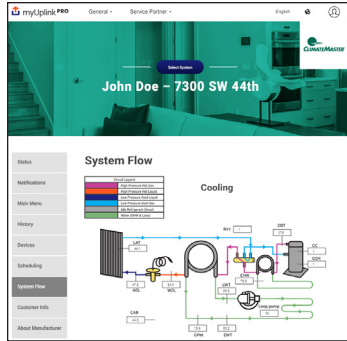

iGate 2 establishes a two-way link between the AWC Thermostat and the cloud, adding significant value for both residential and commercial customers. Our new thermostat works with your customers' Tranquility comfort systems to

provide the most efficient link between their system and your services. The customizable monitoring from the myUplink PRO web portal or phone app account allows for continuous system monitoring, analysis, repair recognition, and early warnings for potential system faults that are sent to you and your customer.



Benefits

- Remote login from anywhere, anytime from any internet connected device
- View system fault history with possible root causes
- Information is available for contractors to troubleshoot and diagnose systems remotely
- Secure internet connection keeps homeowner information private
- Access thermostat(s) through Android and iPhone mobile apps

Homeowner | User Experience

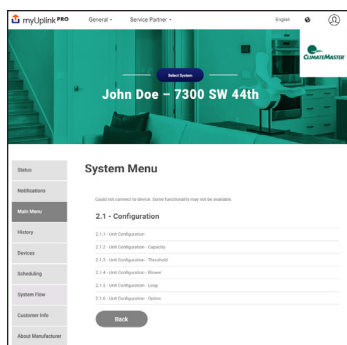

iGate 2 advanced unit controls enable a two-way communication link for critical system information between the unit and the cloud. From any internet connected device or smart phone, building owners can control and monitor their systems

from anywhere in the world. iGate 2 offers building owners peace of mind their systems are operating at peak performance with advanced operational performance issue notifications. HVAC professionals get notifications when systems are operating out of range. They can log in remotely to check system faults, review current operating conditions, and diagnose issues remotely. This gives the HVAC technician the upper hand when showing up to perform service, saving time which in turn, saves money.



Benefits

- Communicates personal settings and reminders through the iGate 2 communication system
- Easy-to-use, full-color, high-resolution user interface
- Sleek, intuitive control panel
- Secure internet connection keeps your information private
- Contains unit model, serial number and your HVAC professionals contact information
- System monitoring automatically contacts HVAC system providers when service is needed

Reference Calculations

Heating	Cooling
$LWT = EWT - \frac{HE}{GPM \times \text{Constant}}$	$LWT = EWT + \frac{HR}{GPM \times \text{Constant}} \quad LC = TC - SC$
$LAT = EAT + \frac{HC}{CFM \times 1.08}$	$LAT (DB) = EAT (DB) - \frac{SC}{CFM \times 1.08} \quad S/T = \frac{SC}{TC}$

Constant = 500 for water, 485 for antifreeze

Conversion Table - to convert inch-pound (English) to S-I (Metric)

Airflow	Water Flow	External Static Pressure	Water Pressure Drop
Airflow (L/s) = CFM x 0.472	Water Flow (L/s) = GPM x 0.0631	ESP (Pa) = ESP (in of wg) x 249	PD (kPa) = PD (ft of hd) x 2.99

Legend and Glossary of Abbreviations

Abbreviations	Descriptions
Btuh	Btu (British Thermal Unit) per hour
BMS	Building Management System
CDT	Compressor discharge temperature
CFM	Airflow, cubic feet per minute
COP	Coefficient of performance = Btuh output/Btuh input
CT EC	Electronically commutated constant torque blower motor
CV EC	Electronically commutated constant volume blower motor
DB	Dry bulb temperature, °F
DT	Delta T
EAT	Entering air temperature
EER	Energy efficient ratio = Btuh output/Watt input
ESP	External static pressure, inches w.g.
EWT	Entering water temperature
FPT	Female pipe thread
GPM	Water flow in U.S., gallons per minute
HC	Air heating capacity, Btuh
HE	Total heat of extraction, Btuh
HGRH	Hot Gas Reheat
HR	Total heat of rejection, Btuh

Abbreviations	Descriptions
HWG	Hot water generator (desuperheater) capacity, MBtuh
kW	Total power unit input, kilowatts
LAT	Leaving air temperature, °F
LC	Latent cooling capacity, Btuh
LOC	Loss of charge
LWT	Leaving water temperature, °F
MBtuh	1,000 Btu per hour
MPT	Male pipe thread
MWV	Motorized water valve
PSC	Permanent split capacitor
RDS	Refrigerant Detection System
SC	Sensible cooling capacity, Btuh
S/T	Sensible to total cooling ratio
TC	Total cooling capacity, Btuh
TD or delta T	Temperature differential
VFD	Variable frequency drive
WB	Wet bulb temperature, °F
WPD	Waterside pressure drop, psi or feet of head
WSE	Waterside economizer

ClimateMaster works continually to improve its products. As a result, the design and specifications of each product at the time of order may be changed without notice and may not be as described herein. Please contact ClimateMaster's Customer Service Department at 800-299-9747 for specific information on the current design and specifications. Statements and other information contained herein are not express warranties and do not form the basis of any bargain between the parties, but are merely ClimateMaster's opinion or commendation of its products. The latest version of this document is available at www.climatemaster.com. Engineered and assembled in the USA. © ClimateMaster, Inc. All Rights Reserved 2024

Selection Procedure

USE THE FOLLOWING SELECTION STEPS

- Determine the actual heating and cooling loads at the desired dry bulb and wet bulb conditions.
- Obtain the following design parameters: Entering water temperature, water flow rate in GPM, airflow in CFM, water flow pressure drop and design wet and dry bulb temperatures. Airflow CFM should be between 300 and 450 CFM per ton. Unit water pressure drop should be kept as close as possible to each other to make water balancing easier. Go to the appropriate tables and find the proper indicated water flow and water temperature.
- Select a unit based on total and sensible cooling conditions. Select a unit which is closest to, but no larger than, the actual cooling load.
- Enter tables at the design water flow and water temperature. Read the total and sensible cooling capacities (Note: interpolation is permissible, extrapolation is not).
- Read the heating capacity. If it exceeds the design criteria it is acceptable. It is quite normal for water-source heat pumps to be selected on cooling capacity only since the heating output is usually greater than the cooling capacity.
- Determine the correction factors associated with the variable factors of dry bulb and wet bulb.

Corrected Total Cooling =
tabulated total cooling x wet bulb correction.

Corrected Sensible Cooling =
tabulated sensible cooling x wet/dry bulb correction.
- Compare the corrected capacities to the load requirements. Normally if the capacities are within 10% of the loads, the equipment is acceptable. It is better to undersize than oversize, as undersizing improves humidity control, reduces sound levels and extends the life of the equipment.
- When completed, calculate water temperature rise and assess the selection. If the units selected are not within 10% of the load calculations, then review what effect changing the GPM, water temperature and/or air flow and air temperature would have on the corrected capacities. If the desired capacity cannot be achieved, select the next larger or smaller unit and repeat the procedure. Remember, when in doubt, undersize slightly for best performance.

EXAMPLE EQUIPMENT SELECTION FOR COOLING

Step 1: Load Determination

Assume we have determined that the appropriate cooling load at the desired dry bulb 80°F and wet bulb 65°F conditions is as follows:

Total Cooling24,500 Btuh
Sensible Cooling 21,800 Btuh
Entering Air Temp80°F Dry Bulb / 65°F Wet Bulb

Step 2: Design Conditions

Similarly, we have also obtained the following design parameters:

Entering Water Temp..... 90°F
Water Flow (Based upon 10°F rise in temp) 6.0 GPM
Airflow750 CFM

Steps 3, 4 & 5: HP Selection

After making our preliminary selection (SR024), we enter the tables at design water flow and water temperature and read Total Cooling, Sensible Cooling and Heat of Rejection capacities:

Total Cooling23,400 Btuh
Sensible Cooling17,500 Btuh
Heat of Rejection 30,200 Btuh

Steps 6 and 7: Entering Airflow Corrections

Next, we determine our correction factors.

Corrected Values	Table	Ent Air	Airflow	Corrected
Corrected Total Cooling	= 23,400	x 0.9681	x 0.9947	= 22,533
Corrected Sensible Cooling	= 17,500	x 1.1213	x 1.0222	= 20,058
Corrected Heat of Rejection	= 30,200	x 0.9747	x 0.9668	= 28,459

Step 8: Water Temperature Rise Calculation and Assessment

Actual Temperature Rise 9.5°F

When we compare the Corrected Total Cooling and Corrected Sensible Cooling values with our load requirements stated in Step 1, we discover that our selection is within ± 10% of our sensible load requirement. Furthermore, we see that our Corrected Total Cooling value is within 1,000 Btuh the actual indicated load.

ClimateMaster works continually to improve its products. As a result, the design and specifications of each product at the time of order may be changed without notice and may not be as described herein. Please contact ClimateMaster's Customer Service Department at 800-299-9747 for specific information on the current design and specifications. Statements and other information contained herein are not express warranties and do not form the basis of any bargain between the parties, but are merely ClimateMaster's opinion or commendation of its products. The latest version of this document is available at www.climatemaster.com. Engineered and assembled in the USA. © ClimateMaster, Inc. All Rights Reserved 2024

Model Nomenclature

Models:
SR
006-060

1 | 2 | 3 | 4 | 5 | 6 | 7 | 8 | 9 | 10 | 11 | 12 | 13 | 14 | 15
S | **R** | **L** | **0** | **2** | **4** | **A** | **G** | **C** | **3** | **0** | **C** | **0** | **P** | **S**

PRODUCT NAME

S = R-454B Refrigerant

MODEL TYPE

R = Versatile Single-Stage Series

SUPPLY & RETURN CONFIGURATIONS

Horizontal Configuration

	Left	Right
Straight	L	R
Back	B	P

Vertical Configuration

	Left	Right
Top	T	K

SIZE

006	018	042
009	024	048
012	030	060
015	036	

REVISION

A = Current

VOLTAGE

A = 115-1-60	B = 115-1-60 Refrigerant Detection System
G = 208/230-1-60	J = 208/230-1-60 Refrigerant Detection System
H = 208/230-3-60	K = 208/230-3-60 Refrigerant Detection System
E = 265-1-60	D = 265-1-60 Refrigerant Detection System
F = 460-3-60	L = 460-3-60 Refrigerant Detection System
N = 575-3-60	M = 575-3-60 Refrigerant Detection System

CONTROLS

Control	Standard	MPC
CXM2	C	N
DXM2.5	D	P
CXM2 with Disconnect	W	R
DXM2.5 with Disconnect	B	S

CABINET

Cabinet	UltraQuiet	Rail		Frame	
		1"	2"	1"	2"
Extended Range	No	1	J	K	A
	Yes	2	L	M	C
Standard Range	No	3	N	P	E
	Yes	4	F	S	G

STANDARD

S = Standard

BLOWER MOTOR

P = Permanent Split Capacitor (PSC)
 T = Constant Torque Electronically Commuted (CT EC)
 V = Constant Volume Electronically Commuted (CV EC)

EXTENDED OPTIONS

Option	Standard	HWG
None	0	G
Hybrid	H	-
WSE	W	-
HGRH	R	-

DRAIN PAN/HEAT EXCHANGER OPTIONS

C = Standard Drain Pan, Non-Coated Air Coil
 T = Standard Drain Pan, Tin-Coated Air Coil
 S = Stainless Steel Drain Pan, Non-Coated Air Coil
 R = Stainless Steel Drain Pan, Tin-Coated Air Coil

WATER/HEAT EXCHANGER OPTIONS

Water Option	Standard	Cupro Nickel
None	0	Z
Motorized Water Valve (MWV)	M	V
Internal Secondary Pump (ISP)	7	-
Auto Flow Regulator (AFR) 2.5 GPM/ton	A	-
AFR 3.0 GPM/ton	F	-
MWV & AFR 2.5 GPM/ton	W	-
MWV & AFR 3.0 GPM/ton	T	-

Use ClimateMaster's selection software at <https://climatemastersolutions.com/eRep/> to configure your Tranquility SR model.

ClimateMaster works continually to improve its products. As a result, the design and specifications of each product at the time of order may be changed without notice and may not be as described herein. Please contact ClimateMaster's Customer Service Department at 800-299-9747 for specific information on the current design and specifications. Statements and other information contained herein are not express warranties and do not form the basis of any bargain between the parties, but are merely ClimateMaster's opinion or commendation of its products. The latest version of this document is available at www.climatemaster.com. Engineered and assembled in the USA. © ClimateMaster, Inc. All Rights Reserved 2024

Performance Data: ASHRAE/AHRI/ISO 13256-1

Models:
SR
006-060

ASHRAE/AHRI/ISO 13256-1 English (I-P) Units

Model	Motor Type	Water Loop Heat Pump				Ground Water Heat Pump				Ground Loop Heat Pump			
		Cooling 86°F		Heating 68°F		Cooling 59°F		Heating 50°F		Full Cooling 77°F		Full Heating 32°F	
		Capacity Btuh	EER Btuh/W	Capacity Btuh	COP	Capacity Btuh	EER Btuh/W	Capacity Btuh	COP	Capacity Btuh	EER Btuh/W	Capacity Btuh	COP
SR006	PSC	5,900	13.4	8,400	4.8	7,200	22.8	6,600	3.9	6,300	15.5	4,900	3.1
	EC	6,100	15.0	8,300	5.1	7,300	26.6	6,500	4.0	6,400	17.7	4,800	3.3
SR009	PSC	8,500	13.8	11,700	4.4	10,000	22.0	9,500	3.9	8,900	15.7	7,200	3.3
	EC	8,600	14.3	11,600	4.5	10,000	23.4	9,500	4.0	9,000	16.7	7,200	3.3
SR012	PSC	10,500	12.7	14,400	4.5	12,800	19.0	11,700	3.9	11,400	14.1	9,300	3.2
	EC	10,700	13.4	14,400	4.6	13,000	21.0	11,700	4.0	11,500	14.9	9,300	3.3
SR015	PSC	14,500	15.2	16,000	4.8	16,700	23.5	13,800	4.3	15,000	16.5	11,000	3.5
	EC	14,700	16.4	15,900	4.9	16,900	26.2	13,800	4.5	15,200	17.3	10,700	3.6
SR018	PSC	17,900	14.3	21,500	4.9	20,700	23.0	17,900	4.2	19,000	16.1	14,000	3.4
	EC	18,000	15.0	21,500	5.1	20,900	25.0	17,700	4.4	19,400	17.3	13,800	3.6
SR024	PSC	24,700	14.7	28,800	5.0	27,500	23.3	24,200	4.4	25,600	17.3	19,000	3.6
	EC	24,900	15.4	28,500	5.1	27,800	24.0	24,000	4.5	25,800	18.0	19,000	3.7
SR030	PSC	28,800	13.7	35,400	4.6	32,400	21.0	29,200	4.1	30,100	16.0	23,300	3.5
	EC	29,200	14.5	35,000	4.8	32,800	23.5	28,800	4.3	30,500	17.3	23,000	3.6
SR036	PSC	34,800	14.6	43,900	4.6	38,800	23.3	36,200	4.0	36,100	16.7	28,500	3.4
	EC	35,200	15.3	43,500	4.8	39,200	25.2	35,800	4.2	36,400	17.4	27,900	3.6
SR042	PSC	41,100	14.0	49,500	4.6	45,200	21.0	40,900	4.0	42,700	16.0	32,700	3.4
	EC	41,800	15.2	48,500	4.9	46,000	22.9	39,900	4.3	43,400	17.4	31,700	3.5
SR048	PSC	48,000	14.3	57,900	4.7	53,000	21.5	48,000	4.1	50,400	16.5	38,000	3.5
	EC	48,900	15.2	57,500	4.8	53,500	22.8	47,700	4.2	50,800	17.6	38,100	3.5
SR060	PSC	59,400	13.2	70,000	4.4	65,800	18.2	59,200	3.9	61,300	15.0	45,400	3.3
	EC	60,200	14.7	68,000	4.7	67,000	21.5	57,100	4.2	62,200	17.4	44,300	3.5

Notes:

- Where dual voltages are available, ratings are based on the lower voltage setting.
- Cooling capacities based upon 80.6°F DB, 66.2°F WB entering air temperature.
- Heating capacities based upon 68°F DB, 59°F WB entering air temperature.
- Ground Loop Heat Pump ratings based on 15% antifreeze solution.

Performance Data: ASHRAE/AHRI/ISO 13256-1

Models:
SR
006-060

ASHRAE/AHRI/ISO 13256-1 Metric (S-I) Units

Model	Motor Type	Water Loop Heat Pump				Ground Water Heat Pump				Ground Loop Heat Pump			
		Cooling 30°C		Heating 20°C		Cooling 15°C		Heating 10°C		Full Cooling 25°C		Full Heating 0°C	
		Capacity kW	EER W/W	Capacity kW	COP	Capacity kW	EER W/W	Capacity kW	COP	Capacity kW	EER W/W	Capacity kW	COP
SR006	PSC	2	3.9	2	4.8	2	6.7	2	3.9	2	4.5	1	3.1
	EC	2	4.4	2	5.1	2	7.8	2	4.0	2	5.2	1	3.3
SR009	PSC	2	4.0	3	4.4	3	6.5	3	3.9	3	4.6	2	3.3
	EC	3	4.2	3	4.5	3	6.9	3	4.0	3	4.9	2	3.3
SR012	PSC	3	3.7	4.2	4.5	3.8	5.6	3	3.9	3	4.1	3	3.2
	EC	3	3.9	4.2	4.6	3.8	6.2	3	4.0	3	4.4	3	3.3
SR015	PSC	4	4.5	4.7	4.8	4.9	6.9	4	4.3	4	4.8	3	3.5
	EC	4	4.8	4.7	4.9	5.0	7.7	4	4.5	4	5.1	3	3.6
SR018	PSC	5	4.2	6.3	4.9	6.1	6.7	5	4.2	6	4.7	4	3.4
	EC	5	4.4	6.3	5.1	6.1	7.3	5	4.4	6	5.1	4	3.6
SR024	PSC	7.2	4.3	8.4	5.0	8.1	6.8	7.1	4.4	7.5	5.1	5.6	3.6
	EC	7.3	4.5	8.4	5.1	8.1	7.0	7.0	4.5	7.6	5.3	5.6	3.7
SR030	PSC	8.4	4.0	10.4	4.6	9.5	6.2	8.6	4.1	8.8	4.7	6.8	3.5
	EC	8.6	4.3	10.3	4.8	9.6	6.9	8.4	4.3	8.9	5.1	6.7	3.6
SR036	PSC	10.2	4.3	12.9	4.6	11.4	6.8	10.6	4.0	10.6	4.9	8.4	3.4
	EC	10.3	4.5	12.7	4.8	11.5	7.4	10.5	4.2	10.7	5.1	8.2	3.6
SR042	PSC	12.0	4.1	14.5	4.6	13.2	6.2	12.0	4.0	12.5	4.7	9.6	3.4
	EC	12.3	4.5	14.2	4.9	13.5	6.7	11.7	4.3	12.7	5.1	9.3	3.5
SR048	PSC	14.1	4.2	17.0	4.7	15.5	6.3	14.1	4.1	14.8	4.8	11.1	3.5
	EC	14.3	4.5	16.9	4.8	15.7	6.7	14.0	4.2	14.9	5.2	11.2	3.5
SR060	PSC	17.4	3.9	20.5	4.4	19.3	5.3	17.3	3.9	18.0	4.4	13.3	3.3
	EC	17.6	4.3	19.9	4.7	19.6	6.3	16.7	4.2	18.2	5.1	13.0	3.5

Notes:

- Where dual voltages are available, ratings are based on the lower voltage setting.
- Cooling capacities based upon 27°C DB, 19°C WB entering air temperature.
- Heating capacities based upon 20°C DB, 15°C WB entering air temperature.
- Ground Loop Heat Pump ratings based on 15% antifreeze solution.

Performance Data: Selection Notes

Models:
SR
006-060

For operation in the shaded area when water is used instead of an antifreeze solution, the LWT (Leaving Water Temperature) must be calculated. Flow must be maintained to a level such that the LWT is maintained above 40°F (4.4°C) when the JW3 jumper is not clipped (see example below). Otherwise, appropriate levels of a proper antifreeze solution should be used in systems with leaving water temperatures of 40°F (4.4°C) or below and the JW3 jumper should be clipped. This is due to the potential of the refrigerant temperature being as low as 32°F (0°C) with 40°F (4.4°C) LWT, which may lead to a nuisance cutout due to the activation of the Low Temperature Protection. JW3 should never be clipped for standard-range equipment or systems without antifreeze.

Example:

At 50°F EWT (Entering Water Temperature) and 1.5 GPM/ton, a 3-ton unit has a HE of 22,500 Btuh. To calculate LWT, rearrange the formula for HE as follows:

$HE = TD \times GPM \times 500$, where HE = Heat of Extraction (Btuh); TD = temperature difference (EWT - LWT) and GPM = U.S. Gallons per Minute.

$$TD = HE / (GPM \times 500)$$

$$TD = 22,500 / (1.5 \times 500)$$

$$TD = 10^\circ F$$

$$LWT = EWT - TD$$

$$LWT = 50 - 10 = 40^\circ F$$

In this example, as long as the EWT does not fall below 50°F, the system will operate as designed. For EWTs below 50°F, higher flow rates will be required (open loop systems, for example, require at least 2 GPM/ton when EWT is below 50°F).

		Heating - EAT 70°F				
	EER	HC	Power kW	HE	LAT	COP
Not Recommended						
		4.0	0.45	2.5	84.6	2.6
8.6	27.4	4.6	0.46	3.0	86.8	2.9
8.6	31.0	4.8	0.47	3.2	87.8	3.0
8.6	33.0	4.9	0.47	3.3	88.3	3.1
8.4	23.3	5.4	0.48	3.8	90.2	3.3
8.5	26.3	5.7	0.49	4.0	91.4	3.4
8.6	27.9	5.9	0.49	4.2	92.1	3.5
8.2	19.8	6.2	0.50	4.5	93.6	3.7
4	22.3	6.6	0.50	4.9	95.0	3.8
	23.7	6.8	0.51	5.0	95.8	3.9
	16.7	7.0	0.51	5.3	96.9	4.0
	18.8	7.4	0.52	5.6	98.5	4.1
		7.6	0.52	5.8	99.3	4.2
			0.53	6.0	100.0	4.3

ClimateMaster works continually to improve its products. As a result, the design and specifications of each product at the time of order may be changed without notice and may not be as described herein. Please contact ClimateMaster's Customer Service Department at 800-299-9747 for specific information on the current design and specifications. Statements and other information contained herein are not express warranties and do not form the basis of any bargain between the parties, but are merely ClimateMaster's opinion or commendation of its products. The latest version of this document is available at www.climate-master.com. Engineered and assembled in the USA. © ClimateMaster, Inc. All Rights Reserved 2024

Performance Data SR*006 (PSC Blower Motor)

Models:
SR
006-060

275 CFM Rated Airflow

EWT °F	WPD			COOLING - EAT 80/67°F					WPD			Heating - EAT 70°F			
	FLOW GPM	PSI	FT	TC	SC	kW	HR	EER	FLOW GPM	PSI	FT	HC	kW	COP	HE
20	Operation Not Recommended								2.0	4.4	10.1	4.4	0.5	2.8	2.8
30	1.0	1.5	3.6	7.5	5.5	0.3	8.4	29.5	1.0	1.5	3.6	4.9	0.5	3.0	3.2
	1.5	2.7	6.1	7.5	5.4	0.2	8.3	31.9	1.5	2.7	6.1	5.0	0.5	3.1	3.4
	2.0	3.8	8.7	7.5	5.3	0.2	8.2	33.2	2.0	3.8	8.7	5.1	0.5	3.1	3.5
40	1.0	1.3	3.0	7.4	5.6	0.3	8.4	25.5	1.0	1.3	3.0	5.6	0.5	3.4	3.9
	1.5	2.3	5.3	7.5	5.6	0.3	8.4	27.7	1.5	2.3	5.3	5.8	0.5	3.5	4.2
	2.0	3.3	7.6	7.5	5.5	0.3	8.4	28.8	2.0	3.3	7.6	6.0	0.5	3.5	4.3
50	1.0	1.1	2.6	7.2	5.5	0.3	8.3	21.9	1.0	1.1	2.6	6.5	0.5	3.8	4.8
	1.5	2.0	4.7	7.3	5.6	0.3	8.4	23.9	1.5	2.0	4.7	6.8	0.5	3.9	5.0
	2.0	2.9	6.7	7.4	5.6	0.3	8.4	24.9	2.0	2.9	6.7	6.9	0.5	4.0	5.2
60	1.0	1.0	2.4	6.8	5.4	0.4	8.1	18.6	1.0	1.0	2.4	7.4	0.5	4.2	5.6
	1.5	1.8	4.2	7.0	5.5	0.3	8.2	20.4	1.5	1.8	4.2	7.7	0.5	4.4	6.0
	2.0	2.6	6.1	7.1	5.5	0.3	8.3	21.3	2.0	2.6	6.1	7.9	0.5	4.5	6.2
70	1.0	1.0	2.2	6.4	5.1	0.4	7.8	15.7	1.0	1.0	2.2	8.3	0.5	4.7	6.5
	1.5	1.7	3.9	6.7	5.3	0.4	8.0	17.2	1.5	1.7	3.9	8.7	0.5	4.9	6.9
	2.0	2.4	5.6	6.8	5.3	0.4	8.1	18.1	2.0	2.4	5.6	8.9	0.5	5.0	7.1
80	1.0	0.9	2.1	6.0	4.8	0.5	7.5	13.1	1.0	0.9	2.1	9.2	0.5	5.1	7.4
	1.5	1.6	3.7	6.2	5.0	0.4	7.7	14.4	1.5	1.6	3.7	9.6	0.5	5.3	7.8
	2.0	2.3	5.3	6.3	5.1	0.4	7.8	15.1	2.0	2.3	5.3	9.9	0.5	5.4	8.0
90	1.0	0.9	2.1	5.5	4.5	0.5	7.2	10.7	1.0	0.9	2.1	10.0	0.5	5.5	8.2
	1.5	1.6	3.6	5.7	4.7	0.5	7.4	11.9	1.5	1.6	3.6	10.4	0.5	5.7	8.6
	2.0	2.2	5.1	5.9	4.8	0.5	7.5	12.5	2.0	2.2	5.1	10.7	0.5	5.8	8.8
100	1.0	0.9	2.1	5.0	4.2	0.6	7.0	8.7	Operation Not Recommended						
	1.5	1.5	3.5	5.2	4.4	0.5	7.1	9.6							
	2.0	2.1	5.0	5.4	4.4	0.5	7.2	10.1							
110	1.0	0.9	2.0	4.5	3.9	0.6	6.7	7.0							
	1.5	1.5	3.4	4.7	4.1	0.6	6.8	7.8							
	2.0	2.1	4.8	4.8	4.1	0.6	6.9	8.2							
120	1.0	0.8	1.9	4.0	3.7	0.7	6.5	5.6							
	1.5	1.4	3.3	4.2	3.8	0.7	6.6	6.2							
	2.0	2.0	4.7	4.3	3.8	0.7	6.6	6.5							

Notes:

- Interpolation is permissible; extrapolation is not.
- All entering air conditions are 80°F (26.6°C) DB and 67°F (19.4°C) WB in cooling, and 70°F (21°C) DB in heating.
- Table does not reflect fan or pump power corrections for AHRI/ISO conditions.
- All performance is based upon the lower voltage of dual voltage rated units.
- Performance stated is at the rated power supply; performance may vary as the power supply varies from the rated.
- Operation below 40°F (4.4°C) is based upon 20% methanol antifreeze solution.
- Operation below 60°F (15.5°C) EWT requires optional insulated water/refrigerant circuit.
- See performance correction tables for operating conditions other than those listed above.
- See Performance Data Selection Notes for operation in the shaded areas.
- Performance capacities shown in thousands of Btu/h.
- For unit operation in the shaded area when LWT is below 40°F (4.4°C), antifreeze must be used and the JW3 jumper on the DXM2.5/CXM2 should be clipped. This is due to the potential of the refrigerant temperature being as low as 32°F (0°C) with 40°F (4.4°C) LWT, which may lead to a nuisance cutout due to the activation of the Low Temperature Protection. JW3 should never be clipped for standard range equipment or systems without antifreeze.

Performance Data SR*006 (EC Blower Motor)

Models:
SR
006-060

275 CFM Rated Airflow

EWT °F	WPD			COOLING - EAT 80/67°F					WPD			Heating - EAT 70°F			
	FLOW GPM	PSI	FT	TC	SC	kW	HR	EER	FLOW GPM	PSI	FT	HC	kW	COP	HE
20	Operation Not Recommended								2.0	4.4	10.1	4.4	0.4	2.8	2.8
30	1.0	1.5	3.6	7.6	5.5	0.2	8.4	31.7	1.0	1.5	3.6	4.8	0.5	3.1	3.2
	1.5	2.7	6.1	7.6	5.4	0.2	8.3	34.5	1.5	2.7	6.1	5.0	0.5	3.1	3.4
	2.0	3.8	8.7	7.5	5.4	0.2	8.2	36.0	2.0	3.8	8.7	5.0	0.5	3.2	3.5
40	1.0	1.3	3.0	7.5	5.6	0.3	8.4	27.2	1.0	1.3	3.0	5.6	0.5	3.4	3.9
	1.5	2.3	5.3	7.5	5.6	0.3	8.4	29.6	1.5	2.3	5.3	5.8	0.5	3.6	4.2
	2.0	3.3	7.6	7.6	5.6	0.2	8.4	30.9	2.0	3.3	7.6	5.9	0.5	3.6	4.3
50	1.0	1.1	2.6	7.2	5.6	0.3	8.3	23.2	1.0	1.1	2.6	6.4	0.5	3.9	4.8
	1.5	2.0	4.7	7.4	5.6	0.3	8.4	25.4	1.5	2.0	4.7	6.7	0.5	4.0	5.0
	2.0	2.9	6.7	7.4	5.6	0.3	8.4	26.5	2.0	2.9	6.7	6.9	0.5	4.1	5.2
60	1.0	1.0	2.4	6.9	5.4	0.4	8.1	19.7	1.0	1.0	2.4	7.3	0.5	4.3	5.6
	1.5	1.8	4.2	7.1	5.5	0.3	8.2	21.5	1.5	1.8	4.2	7.7	0.5	4.5	6.0
	2.0	2.6	6.1	7.2	5.5	0.3	8.3	22.6	2.0	2.6	6.1	7.9	0.5	4.6	6.2
70	1.0	1.0	2.2	6.5	5.2	0.4	7.8	16.5	1.0	1.0	2.2	8.2	0.5	4.8	6.5
	1.5	1.7	3.9	6.7	5.3	0.4	8.0	18.1	1.5	1.7	3.9	8.7	0.5	5.0	6.9
	2.0	2.4	5.6	6.8	5.4	0.4	8.1	19.0	2.0	2.4	5.6	8.9	0.5	5.1	7.1
80	1.0	0.9	2.1	6.0	4.9	0.4	7.5	13.7	1.0	0.9	2.1	9.1	0.5	5.2	7.4
	1.5	1.6	3.7	6.3	5.0	0.4	7.7	15.1	1.5	1.6	3.7	9.6	0.5	5.4	7.8
	2.0	2.3	5.3	6.4	5.1	0.4	7.8	15.8	2.0	2.3	5.3	9.8	0.5	5.5	8.0
90	1.0	0.9	2.1	5.6	4.6	0.5	7.2	11.2	1.0	0.9	2.1	10.0	0.5	5.6	8.2
	1.5	1.6	3.6	5.8	4.7	0.5	7.4	12.4	1.5	1.6	3.6	10.4	0.5	5.8	8.6
	2.0	2.2	5.1	5.9	4.8	0.5	7.5	13.0	2.0	2.2	5.1	10.6	0.5	5.9	8.8
100	1.0	0.9	2.1	5.1	4.3	0.6	7.0	9.1	Operation Not Recommended						
	1.5	1.5	3.5	5.3	4.4	0.5	7.1	10.0							
	2.0	2.1	5.0	5.4	4.5	0.5	7.2	10.6							
110	1.0	0.9	2.0	4.6	4.0	0.6	6.7	7.3							
	1.5	1.5	3.4	4.8	4.1	0.6	6.8	8.1							
	2.0	2.1	4.8	4.9	4.2	0.6	6.9	8.5							
120	1.0	0.8	1.9	4.1	3.7	0.7	6.5	5.8							
	1.5	1.4	3.3	4.3	3.8	0.7	6.6	6.4							
	2.0	2.0	4.7	4.4	3.9	0.7	6.6	6.7							

Notes:

- Interpolation is permissible; extrapolation is not.
- All entering air conditions are 80°F (26.6°C) DB and 67°F (19.4°C) WB in cooling, and 70°F (21°C) DB in heating.
- Table does not reflect fan or pump power corrections for AHRI/ISO conditions.
- All performance is based upon the lower voltage of dual voltage rated units.
- Performance stated is at the rated power supply; performance may vary as the power supply varies from the rated.
- Operation below 40°F (4.4°C) is based upon 20% methanol antifreeze solution.
- Operation below 60°F (15.5°C) EWT requires optional insulated water/refrigerant circuit.
- See performance correction tables for operating conditions other than those listed above.
- See Performance Data Selection Notes for operation in the shaded areas.
- Performance capacities shown in thousands of Btuh.
- For unit operation in the shaded area when LWT is below 40°F (4.4°C), antifreeze must be used and the JW3 jumper on the DXM2.5/CXM2 should be clipped. This is due to the potential of the refrigerant temperature being as low as 32°F (0°C) with 40°F (4.4°C) LWT, which may lead to a nuisance cutout due to the activation of the Low Temperature Protection. JW3 should never be clipped for standard range equipment or systems without antifreeze.

Performance Data SR*009 (PSC Blower Motor)

Models:
SR
006-060

345 CFM Rated Airflow

EWT °F	WPD			COOLING - EAT 80/67°F					WPD			Heating - EAT 70°F			
	FLOW GPM	PSI	FT	TC	SC	kW	HR	EER	FLOW GPM	PSI	FT	HC	kW	COP	HE
20	Operation Not Recommended								2.5	6.3	14.5	6.2	0.7	2.7	3.9
	1.3	1.9	4.4	10.6	7.6	0.4	11.9	28.7	1.3	1.9	4.4	6.9	0.7	3.0	4.6
30	1.9	3.5	8.0	10.7	7.6	0.3	11.8	31.8	1.9	3.5	8.0	7.2	0.7	3.1	4.9
	2.5	5.0	11.6	10.7	7.6	0.3	11.8	33.5	2.5	5.0	11.6	7.4	0.7	3.1	5.0
40	1.3	1.6	3.6	10.4	7.5	0.4	11.8	24.2	1.3	1.6	3.6	8.1	0.7	3.3	5.7
	1.9	2.9	6.6	10.5	7.5	0.4	11.9	26.9	1.9	2.9	6.6	8.5	0.7	3.5	6.0
50	2.5	4.2	9.6	10.6	7.6	0.4	11.9	28.4	2.5	4.2	9.6	8.7	0.7	3.5	6.2
	1.3	1.4	3.2	10.0	7.3	0.5	11.6	20.5	1.3	1.4	3.2	9.3	0.7	3.7	6.8
60	1.9	2.5	5.7	10.2	7.4	0.4	11.8	22.8	1.9	2.5	5.7	9.7	0.7	3.8	7.2
	2.5	3.6	8.3	10.3	7.5	0.4	11.8	24.0	2.5	3.6	8.3	10.0	0.7	3.9	7.4
70	1.3	1.3	2.9	9.5	7.1	0.5	11.4	17.3	1.3	1.3	2.9	10.5	0.8	4.0	7.9
	1.9	2.3	5.2	9.8	7.2	0.5	11.6	19.2	1.9	2.3	5.2	11.0	0.8	4.2	8.4
80	2.5	3.3	7.6	10.0	7.3	0.5	11.6	20.3	2.5	3.3	7.6	11.3	0.8	4.3	8.7
	1.3	1.2	2.8	9.0	6.8	0.6	11.1	14.6	1.3	1.2	2.8	11.7	0.8	4.4	9.0
90	1.9	2.2	5.0	9.3	7.0	0.6	11.3	16.2	1.9	2.2	5.0	12.3	0.8	4.5	9.6
	2.5	3.1	7.2	9.5	7.0	0.6	11.4	17.0	2.5	3.1	7.2	12.6	0.8	4.6	9.9
100	1.3	1.2	2.8	8.4	6.5	0.7	10.7	12.3	1.3	1.2	2.8	12.8	0.8	4.7	10.1
	1.9	2.2	5.0	8.7	6.7	0.6	10.9	13.6	1.9	2.2	5.0	13.5	0.8	4.9	10.7
110	2.5	3.1	7.2	8.9	6.8	0.6	11.0	14.3	2.5	3.1	7.2	13.8	0.8	4.9	11.0
	1.3	1.2	2.8	7.8	6.3	0.8	10.3	10.3	1.3	1.2	2.8	13.9	0.8	5.0	11.1
120	1.9	2.2	5.0	8.1	6.4	0.7	10.6	11.4	1.9	2.2	5.0	14.6	0.8	5.1	11.8
	2.5	3.1	7.2	8.3	6.5	0.7	10.7	12.0	2.5	3.1	7.2	15.0	0.8	5.2	12.1
130	1.3	1.2	2.8	7.1	6.0	0.8	10.0	8.6	Operation Not Recommended						
	1.9	2.1	5.0	7.5	6.1	0.8	10.2	9.5							
140	2.5	3.1	7.2	7.7	6.2	0.8	10.3	10.0	Operation Not Recommended						
	1.3	1.1	2.6	6.5	5.7	0.9	9.6	7.2							
150	1.9	2.1	4.8	6.8	5.9	0.9	9.8	7.9	Operation Not Recommended						
	2.5	3.0	6.9	7.0	5.9	0.8	9.9	8.3							
160	1.3	1.0	2.4	5.9	5.4	1.0	9.2	6.0	Operation Not Recommended						
	1.9	1.9	4.3	6.2	5.6	0.9	9.4	6.6							
170	2.5	2.7	6.3	6.4	5.6	0.9	9.5	6.9	Operation Not Recommended						

Notes:

- Interpolation is permissible; extrapolation is not.
- All entering air conditions are 80°F (26.6°C) DB and 67°F (19.4°C) WB in cooling, and 70°F (21°C) DB in heating.
- Table does not reflect fan or pump power corrections for AHRI/ISO conditions.
- All performance is based upon the lower voltage of dual voltage rated units.
- Performance stated is at the rated power supply; performance may vary as the power supply varies from the rated.
- Operation below 40°F (4.4°C) is based upon 20% methanol antifreeze solution.
- Operation below 60°F (15.5°C) EWT requires optional insulated water/refrigerant circuit.
- See performance correction tables for operating conditions other than those listed above.
- See Performance Data Selection Notes for operation in the shaded areas.
- Performance capacities shown in thousands of Btuh.
- For unit operation in the shaded area when LWT is below 40°F (4.4°C), antifreeze must be used and the JW3 jumper on the DXM2.5/CXM2 should be clipped. This is due to the potential of the refrigerant temperature being as low as 32°F (0°C) with 40°F (4.4°C) LWT, which may lead to a nuisance cutout due to the activation of the Low Temperature Protection. JW3 should never be clipped for standard range equipment or systems without antifreeze.

Performance Data SR*009 (EC Blower Motor)

Models:
SR
006-060

345 CFM Rated Airflow

EWT °F	WPD			COOLING - EAT 80/67°F					WPD			Heating - EAT 70°F			
	FLOW GPM	PSI	FT	TC	SC	kW	HR	EER	FLOW GPM	PSI	FT	HC	kW	COP	HE
20	Operation Not Recommended								2.5	6.3	14.5	6.1	0.6	2.8	3.9
	1.3	1.9	4.4	10.7	7.6	0.4	11.9	30.5	1.3	1.9	4.4	6.9	0.7	3.0	4.6
30	1.9	3.5	8.0	10.8	7.7	0.3	11.8	34.1	1.9	3.5	8.0	7.2	0.7	3.1	4.9
	2.5	5.0	11.6	10.8	7.7	0.3	11.8	36.0	2.5	5.0	11.6	7.3	0.7	3.2	5.0
40	1.3	1.6	3.6	10.4	7.5	0.4	11.8	25.6	1.3	1.6	3.6	8.0	0.7	3.4	5.7
	1.9	2.9	6.6	10.6	7.6	0.4	11.9	28.6	1.9	2.9	6.6	8.4	0.7	3.5	6.0
50	2.5	4.2	9.6	10.7	7.6	0.4	11.9	30.2	2.5	4.2	9.6	8.6	0.7	3.6	6.2
	1.3	1.4	3.2	10.1	7.3	0.5	11.6	21.5	1.3	1.4	3.2	9.2	0.7	3.8	6.8
60	1.9	2.5	5.7	10.3	7.4	0.4	11.8	24.0	1.9	2.5	5.7	9.7	0.7	3.9	7.2
	2.5	3.6	8.3	10.4	7.5	0.4	11.8	25.4	2.5	3.6	8.3	9.9	0.7	4.0	7.4
70	1.3	1.3	2.9	9.6	7.1	0.5	11.4	18.1	1.3	1.3	2.9	10.4	0.7	4.1	7.9
	1.9	2.3	5.2	9.9	7.3	0.5	11.6	20.1	1.9	2.3	5.2	10.9	0.7	4.3	8.4
80	2.5	3.3	7.6	10.0	7.3	0.5	11.6	21.3	2.5	3.3	7.6	11.2	0.8	4.4	8.7
	1.3	1.2	2.8	9.0	6.9	0.6	11.1	15.2	1.3	1.2	2.8	11.6	0.8	4.5	9.0
90	1.9	2.2	5.0	9.4	7.0	0.6	11.3	16.9	1.9	2.2	5.0	12.2	0.8	4.6	9.6
	2.5	3.1	7.2	9.5	7.1	0.5	11.4	17.8	2.5	3.1	7.2	12.5	0.8	4.7	9.9
100	1.3	1.2	2.8	8.5	6.6	0.7	10.7	12.8	1.3	1.2	2.8	12.8	0.8	4.8	10.1
	1.9	2.2	5.0	8.8	6.8	0.6	10.9	14.1	1.9	2.2	5.0	13.4	0.8	5.0	10.7
110	2.5	3.1	7.2	9.0	6.8	0.6	11.0	14.9	2.5	3.1	7.2	13.7	0.8	5.0	11.0
	1.3	1.2	2.8	7.8	6.3	0.7	10.3	10.7	1.3	1.2	2.8	13.9	0.8	5.1	11.1
120	1.9	2.2	5.0	8.2	6.5	0.7	10.6	11.8	1.9	2.2	5.0	14.5	0.8	5.2	11.8
	2.5	3.1	7.2	8.4	6.6	0.7	10.7	12.4	2.5	3.1	7.2	14.9	0.8	5.3	12.1
130	1.3	1.2	2.8	7.2	6.0	0.8	10.0	8.9	Operation Not Recommended						
	1.9	2.1	5.0	7.5	6.2	0.8	10.2	9.8							
140	2.5	3.1	7.2	7.7	6.3	0.7	10.3	10.3							
	1.3	1.1	2.6	6.6	5.8	0.9	9.6	7.4							
150	1.9	2.1	4.8	6.9	5.9	0.8	9.8	8.2							
	2.5	3.0	6.9	7.1	6.0	0.8	9.9	8.6							
160	1.3	1.0	2.4	6.0	5.5	1.0	9.2	6.2							
	1.9	1.9	4.3	6.3	5.6	0.9	9.4	6.8							
170	2.5	2.7	6.3	6.4	5.7	0.9	9.5	7.1							

Notes:

- Interpolation is permissible; extrapolation is not.
- All entering air conditions are 80°F (26.6°C) DB and 67°F (19.4°C) WB in cooling, and 70°F (21°C) DB in heating.
- Table does not reflect fan or pump power corrections for AHRI/ISO conditions.
- All performance is based upon the lower voltage of dual voltage rated units.
- Performance stated is at the rated power supply; performance may vary as the power supply varies from the rated.
- Operation below 40°F (4.4°C) is based upon 20% methanol antifreeze solution.
- Operation below 60°F (15.5°C) EWT requires optional insulated water/refrigerant circuit.
- See performance correction tables for operating conditions other than those listed above.
- See Performance Data Selection Notes for operation in the shaded areas.
- Performance capacities shown in thousands of Btuh.
- For unit operation in the shaded area when LWT is below 40°F (4.4°C), antifreeze must be used and the JW3 jumper on the DXM2.5/CXM2 should be clipped. This is due to the potential of the refrigerant temperature being as low as 32°F (0°C) with 40°F (4.4°C) LWT, which may lead to a nuisance cutout due to the activation of the Low Temperature Protection. JW3 should never be clipped for standard range equipment or systems without antifreeze.

Performance Data SR*012 (PSC Blower Motor)

Models:
SR
006-060

400 CFM Rated Airflow

EWT °F	WPD			COOLING - EAT 80/67°F					WPD			Heating - EAT 70°F			
	FLOW GPM	PSI	FT	TC	SC	kW	HR	EER	FLOW GPM	PSI	FT	HC	kW	COP	HE
20	Operation Not Recommended								3.0	10.0	23.1	8.2	0.9	2.8	5.2
30	1.5	2.7	6.3	13.6	8.6	0.6	15.5	24.3	1.5	2.7	6.3	9.0	0.9	3.0	6.0
	2.3	5.6	13.0	13.8	8.7	0.5	15.5	27.0	2.3	5.6	13.0	9.4	0.9	3.1	6.4
	3.0	8.5	19.6	13.8	8.8	0.5	15.5	28.4	3.0	8.5	19.6	9.7	0.9	3.1	6.6
40	1.5	2.3	5.4	13.3	8.4	0.6	15.4	21.1	1.5	2.3	5.4	10.4	0.9	3.3	7.3
	2.3	4.8	11.1	13.5	8.5	0.6	15.5	23.3	2.3	4.8	11.1	10.9	0.9	3.4	7.8
	3.0	7.3	16.8	13.6	8.6	0.6	15.5	24.5	3.0	7.3	16.8	11.2	0.9	3.5	8.0
50	1.5	2.0	4.7	12.8	8.1	0.7	15.2	18.3	1.5	2.0	4.7	11.9	1.0	3.7	8.6
	2.3	4.2	9.7	13.2	8.3	0.7	15.4	20.1	2.3	4.2	9.7	12.5	1.0	3.8	9.2
	3.0	6.4	14.7	13.3	8.4	0.6	15.4	21.2	3.0	6.4	14.7	12.9	1.0	3.9	9.5
60	1.5	1.8	4.2	12.3	7.9	0.8	14.9	15.8	1.5	1.8	4.2	13.4	1.0	4.0	10.0
	2.3	3.8	8.7	12.7	8.1	0.7	15.1	17.4	2.3	3.8	8.7	14.1	1.0	4.1	10.7
	3.0	5.7	13.2	12.8	8.1	0.7	15.2	18.3	3.0	5.7	13.2	14.5	1.0	4.2	11.0
70	1.5	1.7	3.8	11.6	7.6	0.9	14.6	13.6	1.5	1.7	3.8	14.9	1.0	4.3	11.4
	2.3	3.4	8.0	12.1	7.8	0.8	14.8	15.0	2.3	3.4	8.0	15.6	1.0	4.4	12.1
	3.0	5.2	12.1	12.3	7.9	0.8	14.9	15.8	3.0	5.2	12.1	16.1	1.0	4.5	12.5
80	1.5	1.6	3.6	10.9	7.3	0.9	14.1	11.7	1.5	1.6	3.6	16.3	1.0	4.5	12.7
	2.3	3.2	7.5	11.4	7.5	0.9	14.4	12.9	2.3	3.2	7.5	17.1	1.1	4.7	13.5
	3.0	4.9	11.3	11.6	7.6	0.9	14.5	13.6	3.0	4.9	11.3	17.5	1.1	4.8	13.9
90	1.5	1.5	3.4	10.2	7.0	1.0	13.7	10.0	1.5	1.5	3.4	17.6	1.1	4.8	14.0
	2.3	3.1	7.1	10.7	7.2	1.0	14.0	11.1	2.3	3.1	7.1	18.4	1.1	4.9	14.7
	3.0	4.7	10.8	10.9	7.3	0.9	14.1	11.6	3.0	4.7	10.8	18.9	1.1	5.0	15.1
100	1.5	1.4	3.2	9.4	6.6	1.1	13.2	8.5	Operation Not Recommended						
	2.3	2.9	6.8	9.9	6.8	1.1	13.5	9.4							
	3.0	4.5	10.4	10.1	6.9	1.0	13.6	9.9							
110	1.5	1.3	3.1	8.6	6.3	1.2	12.7	7.2							
	2.3	2.8	6.5	9.1	6.5	1.1	13.0	7.9							
	3.0	4.3	10.0	9.3	6.6	1.1	13.1	8.4							
120	1.5	1.2	2.8	7.8	5.9	1.3	12.2	6.0							
	2.3	2.7	6.1	8.3	6.1	1.2	12.5	6.7							
	3.0	4.1	9.5	8.5	6.2	1.2	12.6	7.0							

Notes:

- Interpolation is permissible; extrapolation is not.
- All entering air conditions are 80°F (26.6°C) DB and 67°F (19.4°C) WB in cooling, and 70°F (21°C) DB in heating.
- Table does not reflect fan or pump power corrections for AHRI/ISO conditions.
- All performance is based upon the lower voltage of dual voltage rated units.
- Performance stated is at the rated power supply; performance may vary as the power supply varies from the rated.
- Operation below 40°F (4.4°C) is based upon 20% methanol antifreeze solution.
- Operation below 60°F (15.5°C) EWT requires optional insulated water/refrigerant circuit.
- See performance correction tables for operating conditions other than those listed above.
- See Performance Data Selection Notes for operation in the shaded areas.
- Performance capacities shown in thousands of Btuh.
- For unit operation in the shaded area when LWT is below 40°F (4.4°C), antifreeze must be used and the JW3 jumper on the DXM2.5/CXM2 should be clipped. This is due to the potential of the refrigerant temperature being as low as 32°F (0°C) with 40°F (4.4°C) LWT, which may lead to a nuisance cutout due to the activation of the Low Temperature Protection. JW3 should never be clipped for standard range equipment or systems without antifreeze.

Performance Data SR*012 (EC Blower Motor)

Models:
SR
006-060

400 CFM Rated Airflow

EWT °F	WPD			COOLING - EAT 80/67°F					WPD			Heating - EAT 70°F			
	FLOW GPM	PSI	FT	TC	SC	kW	HR	EER	FLOW GPM	PSI	FT	HC	kW	COP	HE
20	Operation Not Recommended								3.0	10.0	23.1	8.1	0.8	2.8	5.2
	1.5	2.7	6.3	13.7	8.6	0.5	15.5	25.6	1.5	2.7	6.3	9.0	0.9	3.0	6.0
30	2.3	5.6	13.0	13.8	8.8	0.5	15.5	28.5	2.3	5.6	13.0	9.3	0.9	3.1	6.4
	3.0	8.5	19.6	13.9	8.8	0.5	15.5	30.1	3.0	8.5	19.6	9.6	0.9	3.2	6.6
40	1.5	2.3	5.4	13.4	8.4	0.6	15.4	22.1	1.5	2.3	5.4	10.4	0.9	3.4	7.3
	2.3	4.8	11.1	13.6	8.6	0.6	15.5	24.5	2.3	4.8	11.1	10.9	0.9	3.5	7.8
	3.0	7.3	16.8	13.7	8.7	0.5	15.5	25.8	3.0	7.3	16.8	11.1	0.9	3.6	8.0
50	1.5	2.0	4.7	12.9	8.2	0.7	15.2	19.1	1.5	2.0	4.7	11.8	0.9	3.7	8.6
	2.3	4.2	9.7	13.2	8.4	0.6	15.4	21.1	2.3	4.2	9.7	12.4	0.9	3.9	9.2
	3.0	6.4	14.7	13.4	8.4	0.6	15.4	22.2	3.0	6.4	14.7	12.8	1.0	3.9	9.5
60	1.5	1.8	4.2	12.4	7.9	0.8	14.9	16.4	1.5	1.8	4.2	13.3	1.0	4.0	10.0
	2.3	3.8	8.7	12.8	8.1	0.7	15.1	18.2	2.3	3.8	8.7	14.0	1.0	4.2	10.7
	3.0	5.7	13.2	12.9	8.2	0.7	15.2	19.1	3.0	5.7	13.2	14.4	1.0	4.3	11.0
70	1.5	1.7	3.8	11.7	7.7	0.8	14.6	14.2	1.5	1.7	3.8	14.8	1.0	4.4	11.4
	2.3	3.4	8.0	12.2	7.8	0.8	14.8	15.6	2.3	3.4	8.0	15.6	1.0	4.5	12.1
	3.0	5.2	12.1	12.4	7.9	0.8	14.9	16.4	3.0	5.2	12.1	16.0	1.0	4.6	12.5
80	1.5	1.6	3.6	11.0	7.4	0.9	14.1	12.1	1.5	1.6	3.6	16.2	1.0	4.6	12.7
	2.3	3.2	7.5	11.5	7.5	0.9	14.4	13.4	2.3	3.2	7.5	17.0	1.0	4.8	13.5
	3.0	4.9	11.3	11.7	7.6	0.8	14.5	14.1	3.0	4.9	11.3	17.5	1.1	4.9	13.9
90	1.5	1.5	3.4	10.3	7.0	1.0	13.7	10.4	1.5	1.5	3.4	17.6	1.1	4.9	14.0
	2.3	3.1	7.1	10.7	7.2	0.9	14.0	11.4	2.3	3.1	7.1	18.4	1.1	5.0	14.7
	3.0	4.7	10.8	11.0	7.3	0.9	14.1	12.0	3.0	4.7	10.8	18.8	1.1	5.1	15.1
100	1.5	1.4	3.2	9.5	6.7	1.1	13.2	8.8	Operation Not Recommended						
	2.3	2.9	6.8	10.0	6.9	1.0	13.5	9.7							
	3.0	4.5	10.4	10.2	7.0	1.0	13.6	10.2							
110	1.5	1.3	3.1	8.7	6.3	1.2	12.7	7.4							
	2.3	2.8	6.5	9.2	6.5	1.1	13.0	8.2							
	3.0	4.3	10.0	9.4	6.6	1.1	13.1	8.6							
120	1.5	1.2	2.8	7.9	6.0	1.3	12.2	6.2							
	2.3	2.7	6.1	8.3	6.2	1.2	12.5	6.9							
	3.0	4.1	9.5	8.6	6.3	1.2	12.6	7.2							

Notes:

- Interpolation is permissible; extrapolation is not.
- All entering air conditions are 80°F (26.6°C) DB and 67°F (19.4°C) WB in cooling, and 70°F (21°C) DB in heating.
- Table does not reflect fan or pump power corrections for AHRI/ISO conditions.
- All performance is based upon the lower voltage of dual voltage rated units.
- Performance stated is at the rated power supply; performance may vary as the power supply varies from the rated.
- Operation below 40°F (4.4°C) is based upon 20% methanol antifreeze solution.
- Operation below 60°F (15.5°C) EWT requires optional insulated water/refrigerant circuit.
- See performance correction tables for operating conditions other than those listed above.
- See Performance Data Selection Notes for operation in the shaded areas.
- Performance capacities shown in thousands of Btuh.
- For unit operation in the shaded area when LWT is below 40°F (4.4°C), antifreeze must be used and the JW3 jumper on the DXM2.5/CXM2 should be clipped. This is due to the potential of the refrigerant temperature being as low as 32°F (0°C) with 40°F (4.4°C) LWT, which may lead to a nuisance cutout due to the activation of the Low Temperature Protection. JW3 should never be clipped for standard range equipment or systems without antifreeze.

Performance Data SR*015 (PSC Blower Motor)

Models:
SR
006-060

525 CFM Rated Airflow

EWT °F	WPD			COOLING - EAT 80/67°F					WPD			Heating - EAT 70°F			
	FLOW GPM	PSI	FT	TC	SC	kW	HR	EER	FLOW GPM	PSI	FT	HC	kW	COP	HE
20	Operation Not Recommended								3.8	5.3	12.3	9.5	0.9	2.9	6.2
	1.9	1.8	4.1	17.5	12.3	0.6	19.6	28.4	1.9	1.8	4.1	10.6	1.0	3.2	7.3
30	2.8	3.1	7.1	17.6	12.2	0.6	19.5	31.1	2.8	3.1	7.1	11.0	1.0	3.3	7.7
	3.8	4.4	10.2	17.6	12.0	0.5	19.4	32.6	3.8	4.4	10.2	11.3	1.0	3.3	7.9
40	1.9	1.5	3.4	17.2	12.2	0.7	19.6	24.7	1.9	1.5	3.4	12.2	1.0	3.5	8.8
	2.8	2.6	6.0	17.4	12.3	0.6	19.6	27.2	2.8	2.6	6.0	12.7	1.0	3.7	9.3
50	3.8	3.7	8.6	17.5	12.3	0.6	19.6	28.6	3.8	3.7	8.6	13.0	1.0	3.7	9.5
	1.9	1.3	2.9	16.8	11.9	0.8	19.5	21.5	1.9	1.3	2.9	13.8	1.0	3.9	10.3
60	2.8	2.3	5.3	17.1	12.2	0.7	19.6	23.7	2.8	2.3	5.3	14.4	1.1	4.0	10.9
	3.8	3.3	7.6	17.2	12.3	0.7	19.6	24.9	3.8	3.3	7.6	14.8	1.1	4.1	11.2
70	1.9	1.2	2.7	16.2	11.5	0.9	19.2	18.5	1.9	1.2	2.7	15.4	1.1	4.2	11.8
	2.8	2.1	4.8	16.6	11.8	0.8	19.4	20.5	2.8	2.1	4.8	16.1	1.1	4.4	12.4
80	3.8	3.0	7.0	16.8	12.0	0.8	19.5	21.6	3.8	3.0	7.0	16.5	1.1	4.4	12.8
	1.9	1.1	2.5	15.5	11.1	1.0	18.8	15.9	1.9	1.1	2.5	17.0	1.1	4.5	13.3
90	2.8	2.0	4.6	16.0	11.4	0.9	19.1	17.7	2.8	2.0	4.6	17.8	1.1	4.7	14.0
	3.8	2.9	6.6	16.2	11.5	0.9	19.2	18.6	3.8	2.9	6.6	18.2	1.1	4.8	14.4
100	1.9	1.1	2.5	14.7	10.6	1.1	18.3	13.6	1.9	1.1	2.5	18.6	1.1	4.8	14.8
	2.8	1.9	4.5	15.2	10.9	1.0	18.7	15.1	2.8	1.9	4.5	19.5	1.1	5.0	15.6
110	3.8	2.8	6.5	15.5	11.1	1.0	18.8	15.9	3.8	2.8	6.5	19.9	1.1	5.1	16.0
	1.9	1.1	2.5	13.7	10.2	1.2	17.7	11.6	1.9	1.1	2.5	20.2	1.2	5.1	16.3
120	2.8	1.9	4.5	14.3	10.5	1.1	18.1	12.9	2.8	1.9	4.5	21.1	1.2	5.3	17.2
	3.8	2.8	6.4	14.6	10.6	1.1	18.3	13.6	3.8	2.8	6.4	21.7	1.2	5.4	17.7
100	1.9	1.1	2.5	12.6	9.9	1.3	17.0	9.7	Operation Not Recommended						
	2.8	1.9	4.4	13.3	10.1	1.2	17.4	10.8							
110	3.8	2.7	6.3	13.6	10.2	1.2	17.7	11.5							
	1.9	1.0	2.4	11.4	9.7	1.4	16.2	8.1							
120	2.8	1.8	4.3	12.1	9.8	1.3	16.7	9.0							
	3.8	2.6	6.1	12.5	9.9	1.3	16.9	9.6							
100	1.9	0.9	2.2	10.1	9.4	1.5	15.3	6.6							
	2.8	1.7	3.9	10.8	9.6	1.5	15.8	7.4							
110	3.8	2.4	5.6	11.2	9.6	1.4	16.0	7.9							

Notes:

- Interpolation is permissible; extrapolation is not.
- All entering air conditions are 80°F (26.6°C) DB and 67°F (19.4°C) WB in cooling, and 70°F (21°C) DB in heating.
- Table does not reflect fan or pump power corrections for AHRI/ISO conditions.
- All performance is based upon the lower voltage of dual voltage rated units.
- Performance stated is at the rated power supply; performance may vary as the power supply varies from the rated.
- Operation below 40°F (4.4°C) is based upon 20% methanol antifreeze solution.
- Operation below 60°F (15.5°C) EWT requires optional insulated water/refrigerant circuit.
- See performance correction tables for operating conditions other than those listed above.
- See Performance Data Selection Notes for operation in the shaded areas.
- Performance capacities shown in thousands of Btuh.
- For unit operation in the shaded area when LWT is below 40°F (4.4°C), antifreeze must be used and the JW3 jumper on the DXM2.5/CXM2 should be clipped. This is due to the potential of the refrigerant temperature being as low as 32°F (0°C) with 40°F (4.4°C) LWT, which may lead to a nuisance cutout due to the activation of the Low Temperature Protection. JW3 should never be clipped for standard range equipment or systems without antifreeze.

Performance Data SR*015 (EC Blower Motor)

Models:
SR
006-060

525 CFM Rated Airflow

EWT °F	WPD			COOLING - EAT 80/67°F					WPD			Heating - EAT 70°F			
	FLOW GPM	PSI	FT	TC	SC	kW	HR	EER	FLOW GPM	PSI	FT	HC	kW	COP	HE
20	Operation Not Recommended								3.8	5.3	12.3	9.4	0.9	3.0	6.2
30	1.9	1.8	4.1	17.6	12.4	0.6	19.6	30.0	1.9	1.8	4.1	10.5	0.9	3.3	7.3
	2.8	3.1	7.1	17.7	12.2	0.5	19.5	33.1	2.8	3.1	7.1	10.9	1.0	3.4	7.7
	3.8	4.4	10.2	17.7	12.1	0.5	19.4	34.7	3.8	4.4	10.2	11.2	1.0	3.4	7.9
40	1.9	1.5	3.4	17.3	12.3	0.7	19.6	26.0	1.9	1.5	3.4	12.1	1.0	3.6	8.8
	2.8	2.6	6.0	17.5	12.4	0.6	19.6	28.7	2.8	2.6	6.0	12.6	1.0	3.7	9.3
	3.8	3.7	8.6	17.6	12.4	0.6	19.6	30.2	3.8	3.7	8.6	12.9	1.0	3.8	9.5
50	1.9	1.3	2.9	16.9	12.0	0.8	19.5	22.5	1.9	1.3	2.9	13.7	1.0	4.0	10.3
	2.8	2.3	5.3	17.2	12.2	0.7	19.6	24.9	2.8	2.3	5.3	14.3	1.0	4.1	10.9
	3.8	3.3	7.6	17.3	12.3	0.7	19.6	26.2	3.8	3.3	7.6	14.7	1.0	4.2	11.2
60	1.9	1.2	2.7	16.3	11.6	0.8	19.2	19.3	1.9	1.2	2.7	15.3	1.0	4.3	11.8
	2.8	2.1	4.8	16.7	11.9	0.8	19.4	21.4	2.8	2.1	4.8	16.0	1.1	4.5	12.4
	3.8	3.0	7.0	16.9	12.0	0.7	19.5	22.6	3.8	3.0	7.0	16.4	1.1	4.5	12.8
70	1.9	1.1	2.5	15.6	11.1	0.9	18.8	16.6	1.9	1.1	2.5	16.9	1.1	4.6	13.3
	2.8	2.0	4.6	16.1	11.4	0.9	19.1	18.4	2.8	2.0	4.6	17.7	1.1	4.8	14.0
	3.8	2.9	6.6	16.3	11.6	0.8	19.2	19.4	3.8	2.9	6.6	18.1	1.1	4.9	14.4
80	1.9	1.1	2.5	14.8	10.7	1.0	18.3	14.1	1.9	1.1	2.5	18.5	1.1	4.9	14.8
	2.8	1.9	4.5	15.3	11.0	1.0	18.7	15.7	2.8	1.9	4.5	19.4	1.1	5.1	15.6
	3.8	2.8	6.5	15.6	11.1	0.9	18.8	16.6	3.8	2.8	6.5	19.8	1.1	5.2	16.0
90	1.9	1.1	2.5	13.8	10.3	1.2	17.7	12.0	1.9	1.1	2.5	20.1	1.1	5.2	16.3
	2.8	1.9	4.5	14.4	10.5	1.1	18.1	13.3	2.8	1.9	4.5	21.0	1.1	5.4	17.2
	3.8	2.8	6.4	14.7	10.7	1.0	18.3	14.1	3.8	2.8	6.4	21.6	1.1	5.5	17.7
100	1.9	1.1	2.5	12.7	10.0	1.3	17.0	10.1	Operation Not Recommended						
	2.8	1.9	4.4	13.4	10.2	1.2	17.4	11.2							
	3.8	2.7	6.3	13.7	10.3	1.2	17.7	11.8							
110	1.9	1.0	2.4	11.5	9.8	1.4	16.2	8.4							
	2.8	1.8	4.3	12.2	9.9	1.3	16.7	9.3							
	3.8	2.6	6.1	12.6	10.0	1.3	16.9	9.9							
120	1.9	0.9	2.2	10.2	9.5	1.5	15.3	6.8							
	2.8	1.7	3.9	10.9	9.7	1.4	15.8	7.7							
	3.8	2.4	5.6	11.3	9.7	1.4	16.0	8.1							

Notes:

- Interpolation is permissible; extrapolation is not.
- All entering air conditions are 80°F (26.6°C) DB and 67°F (19.4°C) WB in cooling, and 70°F (21°C) DB in heating.
- Table does not reflect fan or pump power corrections for AHRI/ISO conditions.
- All performance is based upon the lower voltage of dual voltage rated units.
- Performance stated is at the rated power supply; performance may vary as the power supply varies from the rated.
- Operation below 40°F (4.4°C) is based upon 20% methanol antifreeze solution.
- Operation below 60°F (15.5°C) EWT requires optional insulated water/refrigerant circuit.
- See performance correction tables for operating conditions other than those listed above.
- See Performance Data Selection Notes for operation in the shaded areas.
- Performance capacities shown in thousands of Btu/h.
- For unit operation in the shaded area when LWT is below 40°F (4.4°C), antifreeze must be used and the JW3 jumper on the DXM2.5/CXM2 should be clipped. This is due to the potential of the refrigerant temperature being as low as 32°F (0°C) with 40°F (4.4°C) LWT, which may lead to a nuisance cutout due to the activation of the Low Temperature Protection. JW3 should never be clipped for standard range equipment or systems without antifreeze.

Performance Data SR*018 (PSC Blower Motor)

Models:
SR
006-060

630 CFM Rated Airflow

EWT °F	WPD			COOLING - EAT 80/67°F					WPD			Heating - EAT 70°F			
	FLOW GPM	PSI	FT	TC	SC	kW	HR	EER	FLOW GPM	PSI	FT	HC	kW	COP	HE
20	Operation Not Recommended								4.5	9.2	21.1	11.9	1.2	3.0	7.9
30	2.3	2.7	6.3	23.0	15.7	0.8	25.6	29.8	2.3	2.7	6.3	13.2	1.2	3.2	9.1
	3.4	5.2	12.1	23.5	16.0	0.7	25.9	33.8	3.4	5.2	12.1	13.8	1.2	3.3	9.7
	4.5	7.7	17.9	23.8	16.2	0.7	26.1	36.0	4.5	7.7	17.9	14.1	1.2	3.4	10.0
40	2.3	2.4	5.6	22.2	15.3	0.9	25.2	25.3	2.3	2.4	5.6	15.3	1.2	3.6	11.0
	3.4	4.6	10.5	22.8	15.6	0.8	25.5	28.7	3.4	4.6	10.5	16.0	1.3	3.7	11.7
	4.5	6.7	15.4	23.1	15.8	0.8	25.7	30.5	4.5	6.7	15.4	16.4	1.3	3.8	12.0
50	2.3	2.2	5.1	21.4	15.0	1.0	24.8	21.5	2.3	2.2	5.1	17.3	1.3	3.9	12.9
	3.4	4.1	9.4	22.0	15.2	0.9	25.1	24.3	3.4	4.1	9.4	18.1	1.3	4.0	13.6
	4.5	5.9	13.7	22.3	15.4	0.9	25.3	25.8	4.5	5.9	13.7	18.5	1.3	4.1	14.0
60	2.3	2.1	4.8	20.6	14.6	1.1	24.4	18.2	2.3	2.1	4.8	19.3	1.3	4.2	14.7
	3.4	3.8	8.7	21.2	14.9	1.0	24.7	20.5	3.4	3.8	8.7	20.2	1.4	4.4	15.6
	4.5	5.4	12.6	21.5	15.0	1.0	24.9	21.8	4.5	5.4	12.6	20.7	1.4	4.4	16.0
70	2.3	2.0	4.5	19.7	14.2	1.3	24.0	15.5	2.3	2.0	4.5	21.2	1.4	4.5	16.5
	3.4	3.5	8.2	20.3	14.5	1.2	24.3	17.4	3.4	3.5	8.2	22.2	1.4	4.7	17.4
	4.5	5.1	11.9	20.7	14.6	1.1	24.5	18.5	4.5	5.1	11.9	22.8	1.4	4.7	17.9
80	2.3	1.9	4.4	18.7	13.8	1.4	23.5	13.1	2.3	1.9	4.4	23.1	1.4	4.8	18.3
	3.4	3.4	7.9	19.4	14.1	1.3	23.9	14.7	3.4	3.4	7.9	24.2	1.4	4.9	19.3
	4.5	5.0	11.5	19.7	14.3	1.3	24.0	15.6	4.5	5.0	11.5	24.8	1.4	5.0	19.8
90	2.3	1.8	4.2	17.6	13.3	1.6	23.0	11.1	2.3	1.8	4.2	25.0	1.4	5.1	20.0
	3.4	3.3	7.7	18.3	13.7	1.5	23.3	12.5	3.4	3.3	7.7	26.1	1.5	5.2	21.1
	4.5	4.9	11.2	18.7	13.8	1.4	23.5	13.2	4.5	4.9	11.2	26.7	1.5	5.3	21.7
100	2.3	1.8	4.1	16.3	12.8	1.7	22.3	9.4	Operation Not Recommended						
	3.4	3.3	7.5	17.2	13.1	1.6	22.8	10.5							
	4.5	4.8	11.0	17.6	13.3	1.6	23.0	11.1							
110	2.3	1.7	3.9	15.0	12.1	1.9	21.6	7.8							
	3.4	3.2	7.3	15.9	12.5	1.8	22.1	8.8							
	4.5	4.6	10.6	16.3	12.8	1.7	22.3	9.3							
120	2.3	1.6	3.7	13.6	11.3	2.1	20.7	6.5							
	3.4	3.0	6.9	14.5	11.8	2.0	21.3	7.3							
	4.5	4.3	10.0	15.0	12.1	1.9	21.5	7.8							

Notes:

- Interpolation is permissible; extrapolation is not.
- All entering air conditions are 80°F (26.6°C) DB and 67°F (19.4°C) WB in cooling, and 70°F (21°C) DB in heating.
- Table does not reflect fan or pump power corrections for AHRI/ISO conditions.
- All performance is based upon the lower voltage of dual voltage rated units.
- Performance stated is at the rated power supply; performance may vary as the power supply varies from the rated.
- Operation below 40°F (4.4°C) is based upon 20% methanol antifreeze solution.
- Operation below 60°F (15.5°C) EWT requires optional insulated water/refrigerant circuit.
- See performance correction tables for operating conditions other than those listed above.
- See Performance Data Selection Notes for operation in the shaded areas.
- Performance capacities shown in thousands of Btuh.
- For unit operation in the shaded area when LWT is below 40°F (4.4°C), antifreeze must be used and the JW3 jumper on the DXM2.5/CXM2 should be clipped. This is due to the potential of the refrigerant temperature being as low as 32°F (0°C) with 40°F (4.4°C) LWT, which may lead to a nuisance cutout due to the activation of the Low Temperature Protection. JW3 should never be clipped for standard range equipment or systems without antifreeze.

Performance Data SR*018 (EC Blower Motor)

Models:
SR
006-060

630 CFM Rated Airflow

EWT °F	WPD			COOLING - EAT 80/67°F					WPD			Heating - EAT 70°F			
	FLOW GPM	PSI	FT	TC	SC	kW	HR	EER	FLOW GPM	PSI	FT	HC	kW	COP	HE
20	Operation Not Recommended								4.5	9.2	21.1	11.8	1.1	3.0	7.9
30	2.3	2.7	6.3	23.1	15.8	0.8	25.6	30.7	2.3	2.7	6.3	13.1	1.2	3.3	9.1
	3.4	5.2	12.1	23.6	16.1	0.7	25.9	34.9	3.4	5.2	12.1	13.7	1.2	3.4	9.7
	4.5	7.7	17.9	23.9	16.2	0.6	26.1	37.2	4.5	7.7	17.9	14.1	1.2	3.4	10.0
40	2.3	2.4	5.6	22.3	15.4	0.9	25.2	26.0	2.3	2.4	5.6	15.2	1.2	3.6	11.0
	3.4	4.6	10.5	22.9	15.7	0.8	25.5	29.5	3.4	4.6	10.5	15.9	1.2	3.7	11.7
	4.5	6.7	15.4	23.2	15.8	0.7	25.7	31.4	4.5	6.7	15.4	16.3	1.3	3.8	12.0
50	2.3	2.2	5.1	21.5	15.0	1.0	24.8	22.0	2.3	2.2	5.1	17.2	1.3	4.0	12.9
	3.4	4.1	9.4	22.1	15.3	0.9	25.1	24.9	3.4	4.1	9.4	18.0	1.3	4.1	13.6
	4.5	5.9	13.7	22.4	15.4	0.8	25.3	26.5	4.5	5.9	13.7	18.5	1.3	4.2	14.0
60	2.3	2.1	4.8	20.7	14.7	1.1	24.4	18.6	2.3	2.1	4.8	19.2	1.3	4.3	14.7
	3.4	3.8	8.7	21.3	14.9	1.0	24.7	21.0	3.4	3.8	8.7	20.1	1.3	4.4	15.6
	4.5	5.4	12.6	21.6	15.1	1.0	24.9	22.4	4.5	5.4	12.6	20.6	1.3	4.5	16.0
70	2.3	2.0	4.5	19.7	14.3	1.3	24.0	15.8	2.3	2.0	4.5	21.2	1.4	4.6	16.5
	3.4	3.5	8.2	20.4	14.6	1.1	24.3	17.8	3.4	3.5	8.2	22.2	1.4	4.7	17.4
	4.5	5.1	11.9	20.7	14.7	1.1	24.5	18.9	4.5	5.1	11.9	22.7	1.4	4.8	17.9
80	2.3	1.9	4.4	18.7	13.8	1.4	23.5	13.3	2.3	1.9	4.4	23.1	1.4	4.8	18.3
	3.4	3.4	7.9	19.4	14.2	1.3	23.9	15.0	3.4	3.4	7.9	24.1	1.4	5.0	19.3
	4.5	5.0	11.5	19.8	14.3	1.2	24.0	15.9	4.5	5.0	11.5	24.7	1.4	5.1	19.8
90	2.3	1.8	4.2	17.6	13.4	1.6	23.0	11.3	2.3	1.8	4.2	24.9	1.4	5.1	20.0
	3.4	3.3	7.7	18.4	13.7	1.5	23.3	12.7	3.4	3.3	7.7	26.0	1.4	5.3	21.1
	4.5	4.9	11.2	18.8	13.9	1.4	23.5	13.4	4.5	4.9	11.2	26.6	1.5	5.4	21.7
100	2.3	1.8	4.1	16.4	12.8	1.7	22.3	9.5	Operation Not Recommended						
	3.4	3.3	7.5	17.2	13.2	1.6	22.8	10.7							
	4.5	4.8	11.0	17.6	13.4	1.6	23.0	11.3							
110	2.3	1.7	3.9	15.1	12.1	1.9	21.6	7.9							
	3.4	3.2	7.3	16.0	12.6	1.8	22.1	8.9							
	4.5	4.6	10.6	16.4	12.8	1.7	22.3	9.5							
120	2.3	1.6	3.7	13.7	11.4	2.1	20.7	6.6							
	3.4	3.0	6.9	14.6	11.9	2.0	21.3	7.4							
	4.5	4.3	10.0	15.0	12.1	1.9	21.5	7.9							

Notes:

- Interpolation is permissible; extrapolation is not.
- All entering air conditions are 80°F (26.6°C) DB and 67°F (19.4°C) WB in cooling, and 70°F (21°C) DB in heating.
- Table does not reflect fan or pump power corrections for AHRI/ISO conditions.
- All performance is based upon the lower voltage of dual voltage rated units.
- Performance stated is at the rated power supply; performance may vary as the power supply varies from the rated.
- Operation below 40°F (4.4°C) is based upon 20% methanol antifreeze solution.
- Operation below 60°F (15.5°C) EWT requires optional insulated water/refrigerant circuit.
- See performance correction tables for operating conditions other than those listed above.
- See Performance Data Selection Notes for operation in the shaded areas.
- Performance capacities shown in thousands of Btuh.
- For unit operation in the shaded area when LWT is below 40°F (4.4°C), antifreeze must be used and the JW3 jumper on the DXM2.5/CXM2 should be clipped. This is due to the potential of the refrigerant temperature being as low as 32°F (0°C) with 40°F (4.4°C) LWT, which may lead to a nuisance cutout due to the activation of the Low Temperature Protection. JW3 should never be clipped for standard range equipment or systems without antifreeze.

Performance Data SR*024 (PSC Blower Motor)

Models:
SR
006-060

800 CFM Rated Airflow

EWT °F	WPD			COOLING - EAT 80/67°F					WPD			Heating - EAT 70°F			
	FLOW GPM	PSI	FT	TC	SC	kW	HR	EER	FLOW GPM	PSI	FT	HC	kW	COP	HE
20	Operation Not Recommended								6.0	4.2	9.6	17.1	1.7	3.0	11.4
	3.0	1.2	2.7	27.7	18.7	1.1	31.3	26.2	3.0	1.2	2.7	18.7	1.7	3.2	13.0
30	4.5	2.3	5.3	27.1	18.2	1.0	30.5	27.3	4.5	2.3	5.3	19.6	1.7	3.4	13.7
	6.0	3.3	7.7	26.7	17.9	1.0	30.0	27.6	6.0	3.3	7.7	20.0	1.7	3.4	14.2
40	3.0	0.9	2.1	27.9	19.0	1.2	31.9	23.8	3.0	0.9	2.1	21.5	1.7	3.6	15.5
	4.5	1.8	4.2	27.9	18.9	1.1	31.6	25.6	4.5	1.8	4.2	22.5	1.8	3.7	16.4
	6.0	2.7	6.3	27.7	18.7	1.1	31.3	26.3	6.0	2.7	6.3	23.0	1.8	3.8	17.0
50	3.0	0.7	1.7	27.6	19.0	1.3	32.0	21.0	3.0	0.7	1.7	24.2	1.8	3.9	18.1
	4.5	1.5	3.4	27.9	19.0	1.2	32.0	23.0	4.5	1.5	3.4	25.4	1.8	4.1	19.2
	6.0	2.3	5.4	27.9	19.0	1.2	31.9	24.0	6.0	2.3	5.4	26.0	1.8	4.2	19.8
60	3.0	0.6	1.4	26.8	18.7	1.5	31.8	18.2	3.0	0.6	1.4	27.0	1.9	4.3	20.6
	4.5	1.3	3.0	27.4	18.9	1.4	32.0	20.2	4.5	1.3	3.0	28.3	1.9	4.4	21.9
	6.0	2.1	4.8	27.6	19.0	1.3	32.0	21.2	6.0	2.1	4.8	29.0	1.9	4.5	22.5
70	3.0	0.6	1.3	25.7	18.2	1.7	31.3	15.5	3.0	0.6	1.3	29.7	1.9	4.6	23.2
	4.5	1.2	2.7	26.5	18.6	1.5	31.7	17.4	4.5	1.2	2.7	31.2	1.9	4.7	24.5
	6.0	2.0	4.5	26.8	18.7	1.5	31.8	18.3	6.0	2.0	4.5	32.0	2.0	4.8	25.3
80	3.0	0.5	1.2	24.4	17.7	1.9	30.8	13.1	3.0	0.5	1.2	32.4	2.0	4.8	25.7
	4.5	1.1	2.6	25.3	18.1	1.7	31.2	14.7	4.5	1.1	2.6	33.9	2.0	5.0	27.1
	6.0	1.9	4.3	25.7	18.3	1.6	31.3	15.6	6.0	1.9	4.3	34.8	2.0	5.1	27.9
90	3.0	0.5	1.1	23.1	17.0	2.1	30.2	11.0	3.0	0.5	1.1	35.0	2.0	5.1	28.1
	4.5	1.1	2.5	24.0	17.5	1.9	30.6	12.4	4.5	1.1	2.5	36.6	2.1	5.2	29.6
	6.0	1.8	4.3	24.4	17.7	1.9	30.8	13.1	6.0	1.8	4.3	37.5	2.1	5.3	30.4
100	3.0	0.5	1.1	21.7	16.4	2.4	29.8	9.2	Operation Not Recommended						
	4.5	1.1	2.4	22.6	16.8	2.2	30.1	10.3							
	6.0	1.8	4.1	23.1	17.0	2.1	30.2	11.0							
110	3.0	0.4	0.9	20.6	15.9	2.7	29.7	7.7							
	4.5	1.0	2.2	21.3	16.2	2.5	29.7	8.6							
	6.0	1.7	3.9	21.7	16.4	2.4	29.8	9.2							
120	3.0	0.3	0.7	19.7	15.6	3.0	30.0	6.5							
	4.5	0.8	1.9	20.2	15.8	2.8	29.7	7.3							
	6.0	1.5	3.4	20.6	15.9	2.7	29.7	7.7							

Notes:

- Interpolation is permissible; extrapolation is not.
- All entering air conditions are 80°F (26.6°C) DB and 67°F (19.4°C) WB in cooling, and 70°F (21°C) DB in heating.
- Table does not reflect fan or pump power corrections for AHRI/ISO conditions.
- All performance is based upon the lower voltage of dual voltage rated units.
- Performance stated is at the rated power supply; performance may vary as the power supply varies from the rated.
- Operation below 40°F (4.4°C) is based upon 20% methanol antifreeze solution.
- Operation below 60°F (15.5°C) EWT requires optional insulated water/refrigerant circuit.
- See performance correction tables for operating conditions other than those listed above.
- See Performance Data Selection Notes for operation in the shaded areas.
- Performance capacities shown in thousands of Btuh.
- For unit operation in the shaded area when LWT is below 40°F (4.4°C), antifreeze must be used and the JW3 jumper on the DXM2.5/CXM2 should be clipped. This is due to the potential of the refrigerant temperature being as low as 32°F (0°C) with 40°F (4.4°C) LWT, which may lead to a nuisance cutout due to the activation of the Low Temperature Protection. JW3 should never be clipped for standard range equipment or systems without antifreeze.

Performance Data SR*024 (EC Blower Motor)

Models:
SR
006-060

800 CFM Rated Airflow

EWT °F	WPD			COOLING - EAT 80/67°F					WPD			Heating - EAT 70°F			
	FLOW GPM	PSI	FT	TC	SC	kW	HR	EER	FLOW GPM	PSI	FT	HC	kW	COP	HE
20	Operation Not Recommended								6.0	4.2	9.6	17.0	1.6	3.1	11.5
30	3.0	1.2	2.7	27.7	18.7	1.0	31.2	27.2	3.0	1.2	2.7	18.6	1.7	3.3	13.0
	4.5	2.3	5.3	27.1	18.2	1.0	30.3	28.4	4.5	2.3	5.3	19.5	1.7	3.4	13.8
	6.0	3.3	7.7	26.6	17.9	0.9	29.8	28.8	6.0	3.3	7.7	19.9	1.7	3.5	14.2
40	3.0	0.9	2.1	27.9	19.0	1.1	31.8	24.7	3.0	0.9	2.1	21.4	1.7	3.7	15.5
	4.5	1.8	4.2	27.8	18.8	1.0	31.4	26.5	4.5	1.8	4.2	22.4	1.7	3.8	16.5
	6.0	2.7	6.3	27.7	18.7	1.0	31.1	27.3	6.0	2.7	6.3	22.9	1.7	3.9	17.0
50	3.0	0.7	1.7	27.5	19.0	1.3	31.9	21.7	3.0	0.7	1.7	24.1	1.8	4.0	18.1
	4.5	1.5	3.4	27.9	19.0	1.2	31.9	23.8	4.5	1.5	3.4	25.3	1.8	4.1	19.2
	6.0	2.3	5.4	27.9	19.0	1.1	31.8	24.8	6.0	2.3	5.4	25.9	1.8	4.2	19.8
60	3.0	0.6	1.4	26.7	18.7	1.4	31.6	18.7	3.0	0.6	1.4	26.8	1.8	4.3	20.6
	4.5	1.3	3.0	27.3	18.9	1.3	31.8	20.8	4.5	1.3	3.0	28.2	1.8	4.5	21.9
	6.0	2.1	4.8	27.6	19.0	1.3	31.9	21.9	6.0	2.1	4.8	28.9	1.9	4.6	22.5
70	3.0	0.6	1.3	25.7	18.2	1.6	31.2	15.9	3.0	0.6	1.3	29.5	1.9	4.6	23.2
	4.5	1.2	2.7	26.4	18.6	1.5	31.5	17.8	4.5	1.2	2.7	31.0	1.9	4.8	24.5
	6.0	2.0	4.5	26.8	18.7	1.4	31.7	18.8	6.0	2.0	4.5	31.8	1.9	4.9	25.2
80	3.0	0.5	1.2	24.4	17.6	1.8	30.6	13.4	3.0	0.5	1.2	32.2	1.9	4.9	25.6
	4.5	1.1	2.6	25.3	18.1	1.7	31.0	15.1	4.5	1.1	2.6	33.8	2.0	5.1	27.1
	6.0	1.9	4.3	25.7	18.2	1.6	31.2	16.0	6.0	1.9	4.3	34.6	2.0	5.1	27.9
90	3.0	0.5	1.1	23.0	17.0	2.1	30.1	11.2	3.0	0.5	1.1	34.8	2.0	5.1	28.0
	4.5	1.1	2.5	23.9	17.4	1.9	30.4	12.6	4.5	1.1	2.5	36.4	2.0	5.3	29.6
	6.0	1.8	4.3	24.4	17.7	1.8	30.6	13.4	6.0	1.8	4.3	37.3	2.0	5.4	30.4
100	3.0	0.5	1.1	21.7	16.4	2.3	29.7	9.3	Operation Not Recommended						
	4.5	1.1	2.4	22.6	16.8	2.1	29.9	10.5							
	6.0	1.8	4.1	23.0	17.0	2.1	30.1	11.2							
110	3.0	0.4	0.9	20.6	15.9	2.6	29.5	7.8							
	4.5	1.0	2.2	21.3	16.2	2.4	29.6	8.8							
	6.0	1.7	3.9	21.7	16.4	2.3	29.7	9.3							
120	3.0	0.3	0.7	19.7	15.6	3.0	29.8	6.6							
	4.5	0.8	1.9	20.2	15.8	2.7	29.6	7.4							
	6.0	1.5	3.4	20.5	15.9	2.6	29.5	7.8							

Notes:

- Interpolation is permissible; extrapolation is not.
- All entering air conditions are 80°F (26.6°C) DB and 67°F (19.4°C) WB in cooling, and 70°F (21°C) DB in heating.
- Table does not reflect fan or pump power corrections for AHRI/ISO conditions.
- All performance is based upon the lower voltage of dual voltage rated units.
- Performance stated is at the rated power supply; performance may vary as the power supply varies from the rated.
- Operation below 40°F (4.4°C) is based upon 20% methanol antifreeze solution.
- Operation below 60°F (15.5°C) EWT requires optional insulated water/refrigerant circuit.
- See performance correction tables for operating conditions other than those listed above.
- See Performance Data Selection Notes for operation in the shaded areas.
- Performance capacities shown in thousands of Btuh.
- For unit operation in the shaded area when LWT is below 40°F (4.4°C), antifreeze must be used and the JW3 jumper on the DXM2.5/CXM2 should be clipped. This is due to the potential of the refrigerant temperature being as low as 32°F (0°C) with 40°F (4.4°C) LWT, which may lead to a nuisance cutout due to the activation of the Low Temperature Protection. JW3 should never be clipped for standard range equipment or systems without antifreeze.

Performance Data SR*030 (PSC Blower Motor)

Models:
SR
006-060

1,000 CFM Rated Airflow

EWT °F	WPD			COOLING - EAT 80/67°F					WPD			Heating - EAT 70°F			
	FLOW GPM	PSI	FT	TC	SC	kW	HR	EER	FLOW GPM	PSI	FT	HC	kW	COP	HE
20	Operation Not Recommended								7.5	6.6	15.3	20.0	2.0	3.0	13.2
30	3.8	2.0	4.6	33.5	23.1	1.3	37.9	26.1	3.8	2.0	4.6	22.0	2.0	3.2	15.1
	5.6	3.7	8.5	33.4	23.0	1.2	37.5	27.6	5.6	3.7	8.5	22.8	2.0	3.3	15.8
	7.5	5.3	12.3	33.2	22.9	1.2	37.3	28.3	7.5	5.3	12.3	23.2	2.1	3.3	16.2
40	3.8	1.6	3.6	33.2	23.0	1.4	38.1	23.4	3.8	1.6	3.6	25.0	2.1	3.5	17.8
	5.6	2.9	6.7	33.5	23.1	1.3	38.0	25.2	5.6	2.9	6.7	25.9	2.1	3.6	18.7
	7.5	4.4	10.1	33.5	23.1	1.3	37.9	26.0	7.5	4.4	10.1	26.4	2.1	3.7	19.2
50	3.8	1.3	3.0	32.5	22.8	1.6	37.8	20.7	3.8	1.3	3.0	27.9	2.1	3.8	20.6
	5.6	2.4	5.5	33.0	23.0	1.5	38.0	22.4	5.6	2.4	5.5	29.0	2.2	3.9	21.6
	7.5	3.8	8.7	33.2	23.0	1.4	38.1	23.4	7.5	3.8	8.7	29.6	2.2	4.0	22.1
60	3.8	1.1	2.5	31.3	22.5	1.7	37.3	17.9	3.8	1.1	2.5	30.8	2.2	4.1	23.3
	5.6	2.1	4.8	32.1	22.7	1.6	37.7	19.7	5.6	2.1	4.8	32.0	2.2	4.2	24.4
	7.5	3.4	7.8	32.4	22.8	1.6	37.8	20.6	7.5	3.4	7.8	32.7	2.2	4.3	25.1
70	3.8	1.0	2.3	29.9	22.0	2.0	36.6	15.3	3.8	1.0	2.3	33.7	2.3	4.4	26.0
	5.6	1.9	4.4	30.8	22.3	1.8	37.1	16.9	5.6	1.9	4.4	35.1	2.3	4.5	27.3
	7.5	3.2	7.3	31.3	22.5	1.8	37.3	17.8	7.5	3.2	7.3	35.9	2.3	4.5	28.0
80	3.8	1.0	2.2	28.3	21.4	2.2	35.8	13.0	3.8	1.0	2.2	36.7	2.3	4.6	28.7
	5.6	1.9	4.3	29.3	21.8	2.0	36.3	14.4	5.6	1.9	4.3	38.2	2.4	4.7	30.1
	7.5	3.1	7.1	29.9	22.0	2.0	36.6	15.2	7.5	3.1	7.1	39.1	2.4	4.8	30.9
90	3.8	0.9	2.1	26.6	20.7	2.5	35.0	10.9	3.8	0.9	2.1	39.6	2.4	4.9	31.5
	5.6	1.8	4.2	27.7	21.1	2.3	35.5	12.1	5.6	1.8	4.2	41.3	2.4	5.0	33.0
	7.5	3.0	7.0	28.2	21.4	2.2	35.7	12.8	7.5	3.0	7.0	42.3	2.4	5.1	33.9
100	3.8	0.9	2.0	24.8	19.9	2.8	34.3	9.0	Operation Not Recommended						
	5.6	1.8	4.1	25.9	20.4	2.6	34.7	10.1							
	7.5	3.0	6.9	26.4	20.6	2.5	34.9	10.7							
110	3.8	0.8	1.9	23.1	19.1	3.1	33.7	7.4							
	5.6	1.7	3.8	24.1	19.6	2.9	34.0	8.3							
	7.5	2.8	6.5	24.6	19.9	2.8	34.2	8.8							
120	3.8	0.7	1.5	21.5	18.3	3.5	33.4	6.1							
	5.6	1.4	3.3	22.4	18.8	3.3	33.5	6.9							
	7.5	2.5	5.8	22.9	19.0	3.1	33.6	7.3							

Notes:

- Interpolation is permissible; extrapolation is not.
- All entering air conditions are 80°F (26.6°C) DB and 67°F (19.4°C) WB in cooling, and 70°F (21°C) DB in heating.
- Table does not reflect fan or pump power corrections for AHRI/ISO conditions.
- All performance is based upon the lower voltage of dual voltage rated units.
- Performance stated is at the rated power supply; performance may vary as the power supply varies from the rated.
- Operation below 40°F (4.4°C) is based upon 20% methanol antifreeze solution.
- Operation below 60°F (15.5°C) EWT requires optional insulated water/refrigerant circuit.
- See performance correction tables for operating conditions other than those listed above.
- See Performance Data Selection Notes for operation in the shaded areas.
- Performance capacities shown in thousands of Btu/h.
- For unit operation in the shaded area when LWT is below 40°F (4.4°C), antifreeze must be used and the JW3 jumper on the DXM2.5/CXM2 should be clipped. This is due to the potential of the refrigerant temperature being as low as 32°F (0°C) with 40°F (4.4°C) LWT, which may lead to a nuisance cutout due to the activation of the Low Temperature Protection. JW3 should never be clipped for standard range equipment or systems without antifreeze.

Performance Data SR*030 (EC Blower Motor)

Models:
SR
006-060

1,000 CFM Rated Airflow

EWT °F	WPD			COOLING - EAT 80/67°F					WPD			Heating - EAT 70°F			
	FLOW GPM	PSI	FT	TC	SC	kW	HR	EER	FLOW GPM	PSI	FT	HC	kW	COP	HE
20	Operation Not Recommended								7.5	6.6	15.3	19.9	1.9	3.0	13.3
30	3.8	2.0	4.6	33.5	23.1	1.2	37.7	27.3	3.8	2.0	4.6	21.8	2.0	3.3	15.1
	5.6	3.7	8.5	33.4	23.0	1.2	37.4	29.0	5.6	3.7	8.5	22.6	2.0	3.3	15.9
	7.5	5.3	12.3	33.3	22.9	1.1	37.1	29.8	7.5	5.3	12.3	23.1	2.0	3.4	16.3
40	3.8	1.6	3.6	33.2	23.0	1.4	37.9	24.5	3.8	1.6	3.6	24.8	2.0	3.6	17.9
	5.6	2.9	6.7	33.5	23.1	1.3	37.8	26.3	5.6	2.9	6.7	25.7	2.0	3.7	18.7
	7.5	4.4	10.1	33.5	23.1	1.2	37.7	27.3	7.5	4.4	10.1	26.3	2.1	3.7	19.2
50	3.8	1.3	3.0	32.5	22.8	1.5	37.6	21.5	3.8	1.3	3.0	27.7	2.1	3.9	20.6
	5.6	2.4	5.5	33.0	23.0	1.4	37.8	23.4	5.6	2.4	5.5	28.8	2.1	4.0	21.6
	7.5	3.8	8.7	33.2	23.0	1.4	37.9	24.4	7.5	3.8	8.7	29.4	2.1	4.1	22.2
60	3.8	1.1	2.5	31.4	22.5	1.7	37.1	18.6	3.8	1.1	2.5	30.6	2.1	4.2	23.3
	5.6	2.1	4.8	32.1	22.7	1.6	37.5	20.4	5.6	2.1	4.8	31.8	2.2	4.3	24.4
	7.5	3.4	7.8	32.5	22.8	1.5	37.6	21.4	7.5	3.4	7.8	32.5	2.2	4.4	25.1
70	3.8	1.0	2.3	30.0	22.0	1.9	36.4	15.8	3.8	1.0	2.3	33.5	2.2	4.5	26.0
	5.6	1.9	4.4	30.9	22.3	1.8	36.9	17.5	5.6	1.9	4.4	34.9	2.2	4.6	27.3
	7.5	3.2	7.3	31.3	22.5	1.7	37.1	18.5	7.5	3.2	7.3	35.7	2.3	4.6	28.0
80	3.8	1.0	2.2	28.4	21.4	2.1	35.6	13.3	3.8	1.0	2.2	36.5	2.3	4.7	28.7
	5.6	1.9	4.3	29.4	21.8	2.0	36.1	14.8	5.6	1.9	4.3	38.0	2.3	4.8	30.1
	7.5	3.1	7.1	29.9	22.0	1.9	36.4	15.7	7.5	3.1	7.1	38.8	2.3	4.9	30.9
90	3.8	0.9	2.1	26.6	20.7	2.4	34.8	11.1	3.8	0.9	2.1	39.4	2.3	5.0	31.4
	5.6	1.8	4.2	27.7	21.2	2.2	35.3	12.4	5.6	1.8	4.2	41.1	2.4	5.1	33.0
	7.5	3.0	7.0	28.2	21.4	2.1	35.6	13.2	7.5	3.0	7.0	42.0	2.4	5.2	33.9
100	3.8	0.9	2.0	24.9	20.0	2.7	34.1	9.2	Operation Not Recommended						
	5.6	1.8	4.1	25.9	20.4	2.5	34.5	10.3							
	7.5	3.0	6.9	26.5	20.7	2.4	34.7	10.9							
110	3.8	0.8	1.9	23.1	19.2	3.0	33.5	7.6							
	5.6	1.7	3.8	24.1	19.6	2.8	33.8	8.5							
	7.5	2.8	6.5	24.7	19.9	2.7	34.0	9.0							
120	3.8	0.7	1.5	21.5	18.3	3.4	33.2	6.2							
	5.6	1.4	3.3	22.4	18.8	3.2	33.4	7.0							
	7.5	2.5	5.8	22.9	19.1	3.1	33.5	7.4							

Notes:

- Interpolation is permissible; extrapolation is not.
- All entering air conditions are 80°F (26.6°C) DB and 67°F (19.4°C) WB in cooling, and 70°F (21°C) DB in heating.
- Table does not reflect fan or pump power corrections for AHRI/ISO conditions.
- All performance is based upon the lower voltage of dual voltage rated units.
- Performance stated is at the rated power supply; performance may vary as the power supply varies from the rated.
- Operation below 40°F (4.4°C) is based upon 20% methanol antifreeze solution.
- Operation below 60°F (15.5°C) EWT requires optional insulated water/refrigerant circuit.
- See performance correction tables for operating conditions other than those listed above.
- See Performance Data Selection Notes for operation in the shaded areas.
- Performance capacities shown in thousands of Btuh.
- For unit operation in the shaded area when LWT is below 40°F (4.4°C), antifreeze must be used and the JW3 jumper on the DXM2.5/CXM2 should be clipped. This is due to the potential of the refrigerant temperature being as low as 32°F (0°C) with 40°F (4.4°C) LWT, which may lead to a nuisance cutout due to the activation of the Low Temperature Protection. JW3 should never be clipped for standard range equipment or systems without antifreeze.

Performance Data SR*036 (PSC Blower Motor)

Models:
SR
006-060

1,150 CFM Rated Airflow

EWT °F	WPD			COOLING - EAT 80/67°F					WPD			Heating - EAT 70°F			
	FLOW GPM	PSI	FT	TC	SC	kW	HR	EER	FLOW GPM	PSI	FT	HC	kW	COP	HE
20	Operation Not Recommended								9.0	5.1	11.7	24.6	2.4	3.0	16.4
30	3.0	0.9	2.0	38.7	27.4	1.6	44.0	24.9	4.5	1.6	3.8	25.6	2.4	3.1	17.3
	6.0	2.4	5.5	38.0	26.0	1.3	42.4	29.3	6.0	2.4	5.5	27.9	2.5	3.3	19.5
	9.0	4.1	9.5	37.3	25.3	1.2	41.5	30.4	9.0	4.1	9.5	28.9	2.5	3.4	20.4
40	3.0	0.6	1.5	38.3	27.7	1.8	44.3	21.7	4.5	1.3	3.0	29.2	2.5	3.4	20.7
	6.0	1.9	4.3	38.7	27.1	1.5	43.7	26.4	6.0	1.9	4.3	32.1	2.6	3.6	23.3
	9.0	3.4	7.8	38.5	26.7	1.4	43.2	27.9	9.0	3.4	7.8	33.2	2.6	3.7	24.3
50	3.0	0.5	1.2	37.3	27.5	2.0	44.1	18.7	4.5	1.0	2.4	32.9	2.6	3.7	24.0
	6.0	1.5	3.5	38.6	27.6	1.7	44.3	23.2	6.0	1.5	3.5	36.2	2.7	4.0	27.1
	9.0	2.9	6.7	38.7	27.5	1.6	44.1	24.8	9.0	2.9	6.7	37.5	2.7	4.0	28.2
60	3.0	0.4	1.0	35.9	27.0	2.2	43.6	16.0	4.5	0.9	2.1	36.6	2.7	4.0	27.4
	6.0	1.3	3.1	37.8	27.7	1.9	44.3	20.1	6.0	1.3	3.1	40.3	2.8	4.2	30.8
	9.0	2.6	6.0	38.3	27.7	1.8	44.3	21.6	9.0	2.6	6.0	41.8	2.8	4.3	32.1
70	3.0	0.4	0.9	34.3	26.3	2.5	42.8	13.6	4.5	0.8	2.0	40.2	2.8	4.2	30.7
	6.0	1.2	2.9	36.6	27.3	2.1	43.9	17.2	6.0	1.2	2.9	44.4	2.9	4.5	34.5
	9.0	2.4	5.6	37.3	27.5	2.0	44.1	18.6	9.0	2.4	5.6	46.0	2.9	4.6	35.9
80	3.0	0.4	0.9	32.4	25.4	2.8	42.0	11.6	4.5	0.8	1.9	43.8	2.9	4.5	34.0
	6.0	1.2	2.8	35.0	26.6	2.4	43.2	14.6	6.0	1.2	2.8	48.3	3.0	4.7	38.0
	9.0	2.4	5.5	35.8	27.0	2.3	43.5	15.8	9.0	2.4	5.5	50.0	3.1	4.8	39.6
90	3.0	0.4	0.9	30.5	24.5	3.1	41.2	9.8	4.5	0.8	1.9	47.4	3.0	4.6	37.2
	6.0	1.2	2.8	33.2	25.8	2.7	42.3	12.4	6.0	1.2	2.8	52.2	3.1	4.9	41.5
	9.0	2.3	5.4	34.1	26.2	2.5	42.7	13.4	9.0	2.3	5.4	54.0	3.2	5.0	43.1
100	3.0	0.4	0.9	28.7	23.6	3.4	40.4	8.3	Operation Not Recommended						
	6.0	1.2	2.8	31.3	24.9	3.0	41.5	10.5							
	9.0	2.3	5.3	32.2	25.3	2.8	41.9	11.3							
110	3.0	0.4	0.9	27.0	22.9	3.8	40.0	7.1							
	6.0	1.1	2.6	29.3	23.9	3.3	40.7	8.8							
	9.0	2.2	5.2	30.2	24.4	3.2	41.0	9.5							
120	3.0	0.3	0.7	25.6	22.4	4.2	39.9	6.1							
	6.0	1.0	2.3	27.5	23.1	3.7	40.1	7.5							
	9.0	2.1	4.7	28.3	23.5	3.5	40.3	8.1							

Notes:

- Interpolation is permissible; extrapolation is not.
- All entering air conditions are 80°F (26.6°C) DB and 67°F (19.4°C) WB in cooling, and 70°F (21°C) DB in heating.
- Table does not reflect fan or pump power corrections for AHRI/ISO conditions.
- All performance is based upon the lower voltage of dual voltage rated units.
- Performance stated is at the rated power supply; performance may vary as the power supply varies from the rated.
- Operation below 40°F (4.4°C) is based upon 20% methanol antifreeze solution.
- Operation below 60°F (15.5°C) EWT requires optional insulated water/refrigerant circuit.
- See performance correction tables for operating conditions other than those listed above.
- See Performance Data Selection Notes for operation in the shaded areas.
- Performance capacities shown in thousands of Btuh.
- For unit operation in the shaded area when LWT is below 40°F (4.4°C), antifreeze must be used and the JW3 jumper on the DXM2.5/CXM2 should be clipped. This is due to the potential of the refrigerant temperature being as low as 32°F (0°C) with 40°F (4.4°C) LWT, which may lead to a nuisance cutout due to the activation of the Low Temperature Protection. JW3 should never be clipped for standard range equipment or systems without antifreeze.

Performance Data SR*036 (EC Blower Motor)

Models:
SR
006-060

1,150 CFM Rated Airflow

EWT °F	WPD			COOLING - EAT 80/67°F					WPD			Heating - EAT 70°F			
	FLOW GPM	PSI	FT	TC	SC	kW	HR	EER	FLOW GPM	PSI	FT	HC	kW	COP	HE
20	Operation Not Recommended								9.0	5.1	11.7	24.5	2.3	3.1	16.5
30	3.0	0.9	2.0	38.7	27.4	1.5	43.9	25.6	4.5	1.6	3.8	25.5	2.4	3.1	17.4
	6.0	2.4	5.5	38.0	26.0	1.3	42.2	30.2	6.0	2.4	5.5	27.9	2.4	3.4	19.6
	9.0	4.1	9.5	37.3	25.3	1.2	41.3	31.4	9.0	4.1	9.5	28.8	2.5	3.4	20.4
40	3.0	0.6	1.5	38.3	27.7	1.7	44.2	22.2	4.5	1.3	3.0	29.1	2.5	3.5	20.7
	6.0	1.9	4.3	38.7	27.1	1.4	43.6	27.1	6.0	1.9	4.3	32.0	2.5	3.7	23.3
	9.0	3.4	7.8	38.5	26.7	1.3	43.0	28.7	9.0	3.4	7.8	33.1	2.6	3.8	24.3
50	3.0	0.5	1.2	37.3	27.5	2.0	44.0	19.1	4.5	1.0	2.4	32.8	2.6	3.8	24.1
	6.0	1.5	3.5	38.6	27.6	1.6	44.1	23.8	6.0	1.5	3.5	36.1	2.6	4.0	27.1
	9.0	2.9	6.7	38.7	27.5	1.5	43.9	25.4	9.0	2.9	6.7	37.4	2.7	4.1	28.3
60	3.0	0.4	1.0	35.9	27.0	2.2	43.4	16.3	4.5	0.9	2.1	36.5	2.7	4.0	27.4
	6.0	1.3	3.1	37.8	27.7	1.8	44.1	20.5	6.0	1.3	3.1	40.2	2.8	4.3	30.8
	9.0	2.6	6.0	38.3	27.7	1.7	44.2	22.1	9.0	2.6	6.0	41.7	2.8	4.4	32.1
70	3.0	0.4	0.9	34.3	26.3	2.5	42.7	13.9	4.5	0.8	2.0	40.1	2.7	4.3	30.7
	6.0	1.2	2.9	36.6	27.3	2.1	43.7	17.6	6.0	1.2	2.9	44.2	2.9	4.5	34.5
	9.0	2.4	5.6	37.3	27.5	2.0	44.0	19.0	9.0	2.4	5.6	45.8	2.9	4.6	35.9
80	3.0	0.4	0.9	32.4	25.4	2.8	41.9	11.7	4.5	0.8	1.9	43.7	2.8	4.5	34.0
	6.0	1.2	2.8	35.0	26.6	2.4	43.0	14.9	6.0	1.2	2.8	48.2	3.0	4.7	38.0
	9.0	2.4	5.5	35.8	27.0	2.2	43.4	16.1	9.0	2.4	5.5	49.9	3.0	4.8	39.6
90	3.0	0.4	0.9	30.6	24.5	3.1	41.0	9.9	4.5	0.8	1.9	47.3	2.9	4.7	37.2
	6.0	1.2	2.8	33.2	25.8	2.6	42.2	12.6	6.0	1.2	2.8	52.0	3.1	4.9	41.5
	9.0	2.3	5.4	34.1	26.2	2.5	42.6	13.6	9.0	2.3	5.4	53.8	3.2	5.0	43.0
100	3.0	0.4	0.9	28.7	23.7	3.4	40.3	8.4	Operation Not Recommended						
	6.0	1.2	2.8	31.3	24.9	3.0	41.3	10.6							
	9.0	2.3	5.3	32.2	25.3	2.8	41.7	11.5							
110	3.0	0.4	0.9	27.0	22.9	3.8	39.9	7.2							
	6.0	1.1	2.6	29.4	24.0	3.3	40.6	8.9							
	9.0	2.2	5.2	30.2	24.4	3.1	40.9	9.7							
120	3.0	0.3	0.7	25.6	22.4	4.1	39.8	6.2							
	6.0	1.0	2.3	27.6	23.1	3.6	40.0	7.6							
	9.0	2.1	4.7	28.3	23.5	3.5	40.2	8.1							

Notes:

- Interpolation is permissible; extrapolation is not.
- All entering air conditions are 80°F (26.6°C) DB and 67°F (19.4°C) WB in cooling, and 70°F (21°C) DB in heating.
- Table does not reflect fan or pump power corrections for AHRI/ISO conditions.
- All performance is based upon the lower voltage of dual voltage rated units.
- Performance stated is at the rated power supply; performance may vary as the power supply varies from the rated.
- Operation below 40°F (4.4°C) is based upon 20% methanol antifreeze solution.
- Operation below 60°F (15.5°C) EWT requires optional insulated water/refrigerant circuit.
- See performance correction tables for operating conditions other than those listed above.
- See Performance Data Selection Notes for operation in the shaded areas.
- Performance capacities shown in thousands of Btuh.
- For unit operation in the shaded area when LWT is below 40°F (4.4°C), antifreeze must be used and the JW3 jumper on the DXM2.5/CXM2 should be clipped. This is due to the potential of the refrigerant temperature being as low as 32°F (0°C) with 40°F (4.4°C) LWT, which may lead to a nuisance cutout due to the activation of the Low Temperature Protection. JW3 should never be clipped for standard range equipment or systems without antifreeze.

Performance Data SR*042 (PSC Blower Motor)

Models:
SR
006-060

1,350 CFM Rated Airflow

EWT °F	WPD			COOLING - EAT 80/67°F					WPD			Heating - EAT 70°F			
	FLOW GPM	PSI	FT	TC	SC	kW	HR	EER	FLOW GPM	PSI	FT	HC	kW	COP	HE
20	Operation Not Recommended								10.5	3.9	8.9	28.2	2.8	3.0	18.8
	5.3	1.2	2.8	43.9	30.4	1.8	50.0	24.2	5.3	1.2	2.8	30.7	2.8	3.2	21.2
30	7.9	2.2	5.1	43.0	29.5	1.7	48.9	25.0	7.9	2.2	5.1	31.8	2.8	3.3	22.2
	10.5	3.3	7.6	42.5	28.9	1.7	48.2	25.4	10.5	3.3	7.6	32.4	2.8	3.4	22.8
40	5.3	0.9	2.2	44.4	31.3	2.0	51.2	22.3	5.3	0.9	2.2	34.8	2.9	3.5	25.0
	7.9	1.8	4.2	44.2	30.8	1.9	50.6	23.6	7.9	1.8	4.2	36.1	2.9	3.7	26.2
50	10.5	2.8	6.5	43.9	30.5	1.8	50.1	24.1	10.5	2.8	6.5	36.9	2.9	3.7	26.9
	5.3	0.8	1.7	44.1	31.6	2.2	51.6	20.1	5.3	0.8	1.7	39.0	3.0	3.9	28.9
60	7.9	1.6	3.6	44.4	31.5	2.1	51.4	21.5	7.9	1.6	3.6	40.6	3.0	4.0	30.3
	10.5	2.5	5.9	44.4	31.3	2.0	51.2	22.2	10.5	2.5	5.9	41.4	3.0	4.0	31.2
70	5.3	0.7	1.5	43.2	31.4	2.4	51.6	17.7	5.3	0.7	1.5	43.2	3.1	4.1	32.8
	7.9	1.4	3.2	43.9	31.5	2.3	51.7	19.2	7.9	1.4	3.2	45.0	3.1	4.3	34.5
80	10.5	2.3	5.4	44.1	31.6	2.2	51.6	20.0	10.5	2.3	5.4	46.0	3.1	4.3	35.4
	5.3	0.6	1.4	41.9	30.8	2.7	51.2	15.3	5.3	0.6	1.4	47.5	3.2	4.4	36.7
90	7.9	1.3	3.1	42.8	31.2	2.5	51.5	16.9	7.9	1.3	3.1	49.4	3.2	4.5	38.5
	10.5	2.2	5.2	43.2	31.3	2.5	51.6	17.6	10.5	2.2	5.2	50.5	3.2	4.6	39.5
100	5.3	0.6	1.4	40.1	30.0	3.1	50.5	13.1	5.3	0.6	1.4	51.6	3.3	4.6	40.5
	7.9	1.3	3.0	41.2	30.5	2.8	50.9	14.5	7.9	1.3	3.0	53.7	3.3	4.8	42.4
110	10.5	2.2	5.0	41.8	30.8	2.7	51.1	15.2	10.5	2.2	5.0	54.8	3.3	4.8	43.4
	5.3	0.6	1.5	38.0	29.1	3.4	49.8	11.0	5.3	0.6	1.5	55.6	3.4	4.9	44.1
120	7.9	1.3	3.0	39.3	29.6	3.2	50.3	12.3	7.9	1.3	3.0	57.7	3.4	5.0	46.1
	10.5	2.2	5.0	40.0	29.9	3.1	50.5	13.0	10.5	2.2	5.0	58.8	3.4	5.0	47.1
130	5.3	0.6	1.5	35.8	28.1	3.9	49.1	9.2	Operation Not Recommended						
	7.9	1.3	3.0	37.2	28.7	3.6	49.5	10.3							
140	10.5	2.1	4.9	37.9	29.0	3.5	49.7	10.9	Operation Not Recommended						
	5.3	0.6	1.4	33.5	27.2	4.4	48.5	7.6							
150	7.9	1.3	2.9	34.9	27.7	4.1	48.8	8.5	Operation Not Recommended						
	10.5	2.1	4.8	35.6	28.0	3.9	49.0	9.0							
160	5.3	0.6	1.3	31.2	26.3	5.0	48.2	6.2	Operation Not Recommended						
	7.9	1.2	2.7	32.6	26.8	4.6	48.4	7.0							
170	10.5	2.0	4.6	33.3	27.1	4.5	48.5	7.5	Operation Not Recommended						

Notes:

- Interpolation is permissible; extrapolation is not.
- All entering air conditions are 80°F (26.6°C) DB and 67°F (19.4°C) WB in cooling, and 70°F (21°C) DB in heating.
- Table does not reflect fan or pump power corrections for AHRI/ISO conditions.
- All performance is based upon the lower voltage of dual voltage rated units.
- Performance stated is at the rated power supply; performance may vary as the power supply varies from the rated.
- Operation below 40°F (4.4°C) is based upon 20% methanol antifreeze solution.
- Operation below 60°F (15.5°C) EWT requires optional insulated water/refrigerant circuit.
- See performance correction tables for operating conditions other than those listed above.
- See Performance Data Selection Notes for operation in the shaded areas.
- Performance capacities shown in thousands of Btu/h.
- For unit operation in the shaded area when LWT is below 40°F (4.4°C), antifreeze must be used and the JW3 jumper on the DXM2.5/CXM2 should be clipped. This is due to the potential of the refrigerant temperature being as low as 32°F (0°C) with 40°F (4.4°C) LWT, which may lead to a nuisance cutout due to the activation of the Low Temperature Protection. JW3 should never be clipped for standard range equipment or systems without antifreeze.

Performance Data SR*042 (EC Blower Motor)

Models:
SR
006-060

1,350 CFM Rated Airflow

EWT °F	WPD			COOLING - EAT 80/67°F					WPD			Heating - EAT 70°F			
	FLOW GPM	PSI	FT	TC	SC	kW	HR	EER	FLOW GPM	PSI	FT	HC	kW	COP	HE
20	Operation Not Recommended								10.5	3.9	8.9	27.9	2.6	3.1	19.0
30	5.3	1.2	2.8	43.9	30.4	1.7	49.5	26.5	5.3	1.2	2.8	30.4	2.6	3.4	21.4
	7.9	2.2	5.1	43.1	29.5	1.6	48.4	27.6	7.9	2.2	5.1	31.5	2.7	3.5	22.4
	10.5	3.3	7.6	42.6	28.9	1.5	47.7	28.0	10.5	3.3	7.6	32.1	2.7	3.5	23.0
40	5.3	0.9	2.2	44.4	31.3	1.8	50.7	24.3	5.3	0.9	2.2	34.4	2.7	3.7	25.2
	7.9	1.8	4.2	44.2	30.9	1.7	50.1	25.8	7.9	1.8	4.2	35.8	2.7	3.8	26.4
	10.5	2.8	6.5	44.0	30.5	1.7	49.6	26.4	10.5	2.8	6.5	36.5	2.8	3.9	27.1
50	5.3	0.8	1.7	44.2	31.6	2.0	51.1	21.7	5.3	0.8	1.7	38.6	2.8	4.0	29.0
	7.9	1.6	3.6	44.4	31.5	1.9	50.9	23.4	7.9	1.6	3.6	40.2	2.8	4.2	30.5
	10.5	2.5	5.9	44.4	31.4	1.8	50.7	24.2	10.5	2.5	5.9	41.0	2.9	4.2	31.3
60	5.3	0.7	1.5	43.3	31.4	2.3	51.1	19.0	5.3	0.7	1.5	42.8	2.9	4.3	32.9
	7.9	1.4	3.2	43.9	31.6	2.1	51.1	20.7	7.9	1.4	3.2	44.6	2.9	4.4	34.6
	10.5	2.3	5.4	44.1	31.6	2.0	51.1	21.6	10.5	2.3	5.4	45.6	3.0	4.5	35.5
70	5.3	0.6	1.4	41.9	30.8	2.6	50.6	16.3	5.3	0.6	1.4	47.0	3.0	4.6	36.8
	7.9	1.3	3.1	42.8	31.2	2.4	50.9	18.0	7.9	1.3	3.1	49.0	3.0	4.7	38.6
	10.5	2.2	5.2	43.2	31.4	2.3	51.1	18.9	10.5	2.2	5.2	50.0	3.1	4.8	39.5
80	5.3	0.6	1.4	40.1	30.0	2.9	50.0	13.8	5.3	0.6	1.4	51.1	3.1	4.8	40.5
	7.9	1.3	3.0	41.3	30.5	2.7	50.4	15.4	7.9	1.3	3.0	53.2	3.2	4.9	42.4
	10.5	2.2	5.0	41.8	30.8	2.6	50.6	16.2	10.5	2.2	5.0	54.3	3.2	5.0	43.4
90	5.3	0.6	1.5	38.1	29.1	3.3	49.3	11.6	5.3	0.6	1.5	55.0	3.2	5.0	44.1
	7.9	1.3	3.0	39.4	29.7	3.0	49.8	12.9	7.9	1.3	3.0	57.1	3.2	5.2	46.0
	10.5	2.2	5.0	40.0	30.0	2.9	50.0	13.7	10.5	2.2	5.0	58.2	3.3	5.2	47.1
100	5.3	0.6	1.5	35.9	28.1	3.7	48.6	9.6	Operation Not Recommended						
	7.9	1.3	3.0	37.2	28.7	3.5	49.0	10.8							
	10.5	2.1	4.9	37.9	29.0	3.3	49.2	11.4							
110	5.3	0.6	1.4	33.5	27.2	4.3	48.0	7.9							
	7.9	1.3	2.9	34.9	27.8	3.9	48.4	8.9							
	10.5	2.1	4.8	35.7	28.0	3.8	48.5	9.4							
120	5.3	0.6	1.3	31.2	26.4	4.8	47.8	6.4							
	7.9	1.2	2.7	32.6	26.9	4.5	47.9	7.3							
	10.5	2.0	4.6	33.3	27.1	4.3	48.0	7.7							

Notes:

- Interpolation is permissible; extrapolation is not.
- All entering air conditions are 80°F (26.6°C) DB and 67°F (19.4°C) WB in cooling, and 70°F (21°C) DB in heating.
- Table does not reflect fan or pump power corrections for AHRI/ISO conditions.
- All performance is based upon the lower voltage of dual voltage rated units.
- Performance stated is at the rated power supply; performance may vary as the power supply varies from the rated.
- Operation below 40°F (4.4°C) is based upon 20% methanol antifreeze solution.
- Operation below 60°F (15.5°C) EWT requires optional insulated water/refrigerant circuit.
- See performance correction tables for operating conditions other than those listed above.
- See Performance Data Selection Notes for operation in the shaded areas.
- Performance capacities shown in thousands of Btuh.
- For unit operation in the shaded area when LWT is below 40°F (4.4°C), antifreeze must be used and the JW3 jumper on the DXM2.5/CXM2 should be clipped. This is due to the potential of the refrigerant temperature being as low as 32°F (0°C) with 40°F (4.4°C) LWT, which may lead to a nuisance cutout due to the activation of the Low Temperature Protection. JW3 should never be clipped for standard range equipment or systems without antifreeze.

Performance Data SR*048 (PSC Blower Motor)

Models:
SR
006-060

1,550 CFM Rated Airflow

EWT °F	WPD			COOLING - EAT 80/67°F					WPD			Heating - EAT 70°F			
	FLOW GPM	PSI	FT	TC	SC	kW	HR	EER	FLOW GPM	PSI	FT	HC	kW	COP	HE
20	Operation Not Recommended								12.0	6.9	15.8	33.3	3.4	2.9	21.8
	6.0	1.9	4.3	55.4	36.5	2.2	62.8	25.7	6.0	1.9	4.3	36.1	3.4	3.1	24.3
30	9.0	3.8	8.9	55.7	36.5	2.0	62.7	27.4	9.0	3.8	8.9	37.4	3.5	3.2	25.5
	12.0	6.2	14.3	55.8	36.4	2.0	62.5	28.3	12.0	6.2	14.3	38.1	3.5	3.2	26.2
40	6.0	1.7	3.9	54.6	36.3	2.4	62.7	23.1	6.0	1.7	3.9	40.8	3.5	3.4	28.8
	9.0	3.5	8.0	55.2	36.5	2.2	62.8	24.9	9.0	3.5	8.0	42.5	3.6	3.5	30.3
50	12.0	5.7	13.2	55.5	36.5	2.1	62.8	25.8	12.0	5.7	13.2	43.4	3.6	3.6	31.2
	6.0	1.6	3.6	53.4	35.9	2.6	62.3	20.5	6.0	1.6	3.6	45.9	3.6	3.7	33.5
60	9.0	3.2	7.5	54.3	36.2	2.4	62.6	22.3	9.0	3.2	7.5	48.0	3.7	3.8	35.5
	12.0	5.4	12.4	54.7	36.3	2.4	62.7	23.2	12.0	5.4	12.4	49.2	3.7	3.9	36.6
70	6.0	1.5	3.4	51.9	35.3	2.9	61.7	18.0	6.0	1.5	3.4	51.3	3.7	4.0	38.5
	9.0	3.1	7.1	53.0	35.7	2.7	62.1	19.8	9.0	3.1	7.1	53.8	3.8	4.2	40.8
80	12.0	5.2	11.9	53.5	35.9	2.6	62.3	20.6	12.0	5.2	11.9	55.1	3.8	4.2	42.1
	6.0	1.4	3.3	50.1	34.5	3.2	61.0	15.6	6.0	1.4	3.3	56.7	3.9	4.3	43.6
90	9.0	3.0	6.8	51.4	35.1	3.0	61.5	17.2	9.0	3.0	6.8	59.5	3.9	4.4	46.1
	12.0	5.0	11.6	52.0	35.3	2.9	61.8	18.1	12.0	5.0	11.6	61.0	4.0	4.5	47.5
100	6.0	1.4	3.2	48.0	33.7	3.6	60.2	13.3	6.0	1.4	3.2	62.1	4.0	4.6	48.5
	9.0	2.9	6.7	49.4	34.3	3.3	60.8	14.8	9.0	2.9	6.7	65.1	4.0	4.7	51.3
110	12.0	4.9	11.4	50.1	34.6	3.2	61.0	15.6	12.0	4.9	11.4	66.7	4.1	4.8	52.8
	6.0	1.4	3.2	45.6	32.6	4.1	59.4	11.3	6.0	1.4	3.2	67.3	4.1	4.8	53.3
120	9.0	2.9	6.6	47.2	33.3	3.7	60.0	12.6	9.0	2.9	6.6	70.4	4.2	4.9	56.2
	12.0	4.9	11.3	48.0	33.7	3.6	60.2	13.3	12.0	4.9	11.3	72.0	4.2	5.0	57.6
130	6.0	1.3	3.1	43.1	31.5	4.6	58.7	9.4	Operation Not Recommended						
	9.0	2.8	6.5	44.8	32.3	4.2	59.2	10.6							
140	12.0	4.8	11.2	45.6	32.6	4.1	59.4	11.2	Operation Not Recommended						
	6.0	1.3	3.0	40.3	30.3	5.2	58.1	7.7							
150	9.0	2.8	6.4	42.1	31.1	4.8	58.5	8.8	Operation Not Recommended						
	12.0	4.7	11.0	43.0	31.5	4.6	58.7	9.3							
160	6.0	1.2	2.9	37.4	29.0	5.9	57.6	6.3	Operation Not Recommended						
	9.0	2.7	6.1	39.3	29.9	5.5	57.9	7.2							
170	12.0	4.6	10.6	40.2	30.3	5.2	58.0	7.7	Operation Not Recommended						
180	6.0	1.2	2.9	37.4	29.0	5.9	57.6	6.3							

Notes:

- Interpolation is permissible; extrapolation is not.
- All entering air conditions are 80°F (26.6°C) DB and 67°F (19.4°C) WB in cooling, and 70°F (21°C) DB in heating.
- Table does not reflect fan or pump power corrections for AHRI/ISO conditions.
- All performance is based upon the lower voltage of dual voltage rated units.
- Performance stated is at the rated power supply; performance may vary as the power supply varies from the rated.
- Operation below 40°F (4.4°C) is based upon 20% methanol antifreeze solution.
- Operation below 60°F (15.5°C) EWT requires optional insulated water/refrigerant circuit.
- See performance correction tables for operating conditions other than those listed above.
- See Performance Data Selection Notes for operation in the shaded areas.
- Performance capacities shown in thousands of Btu/h.
- For unit operation in the shaded area when LWT is below 40°F (4.4°C), antifreeze must be used and the JW3 jumper on the DXM2.5/CXM2 should be clipped. This is due to the potential of the refrigerant temperature being as low as 32°F (0°C) with 40°F (4.4°C) LWT, which may lead to a nuisance cutout due to the activation of the Low Temperature Protection. JW3 should never be clipped for standard range equipment or systems without antifreeze.

Performance Data SR*048 (EC Blower Motor)

Models:
SR
006-060

1,550 CFM Rated Airflow

EWT °F	WPD			COOLING - EAT 80/67°F					WPD			Heating - EAT 70°F			
	FLOW GPM	PSI	FT	TC	SC	kW	HR	EER	FLOW GPM	PSI	FT	HC	kW	COP	HE
20	Operation Not Recommended								12.0	6.9	15.8	33.1	3.3	3.0	21.9
	6.0	1.9	4.3	55.4	36.5	2.1	62.5	26.8	6.0	1.9	4.3	35.8	3.3	3.1	24.4
30	9.0	3.8	8.9	55.7	36.5	1.9	62.4	28.7	9.0	3.8	8.9	37.1	3.4	3.2	25.6
	12.0	6.2	14.3	55.8	36.4	1.9	62.2	29.7	12.0	6.2	14.3	37.8	3.4	3.3	26.3
40	6.0	1.7	3.9	54.6	36.3	2.3	62.4	24.0	6.0	1.7	3.9	40.6	3.4	3.5	28.8
	9.0	3.5	8.0	55.2	36.5	2.1	62.5	26.0	9.0	3.5	8.0	42.3	3.5	3.6	30.4
50	12.0	5.7	13.2	55.4	36.5	2.1	62.5	26.9	12.0	5.7	13.2	43.2	3.5	3.6	31.3
	6.0	1.6	3.6	53.4	35.9	2.5	62.0	21.3	6.0	1.6	3.6	45.7	3.5	3.8	33.6
60	9.0	3.2	7.5	54.3	36.2	2.3	62.3	23.2	9.0	3.2	7.5	47.7	3.6	3.9	35.5
	12.0	5.4	12.4	54.7	36.3	2.3	62.4	24.1	12.0	5.4	12.4	48.9	3.6	4.0	36.6
70	6.0	1.5	3.4	51.9	35.3	2.8	61.4	18.6	6.0	1.5	3.4	51.0	3.7	4.1	38.5
	9.0	3.1	7.1	53.0	35.7	2.6	61.8	20.4	9.0	3.1	7.1	53.4	3.7	4.2	40.8
80	12.0	5.2	11.9	53.5	35.9	2.5	62.0	21.4	12.0	5.2	11.9	54.8	3.7	4.3	42.0
	6.0	1.4	3.3	50.1	34.5	3.1	60.7	16.0	6.0	1.4	3.3	56.4	3.8	4.4	43.5
90	9.0	3.0	6.8	51.4	35.1	2.9	61.2	17.8	9.0	3.0	6.8	59.2	3.8	4.5	46.1
	12.0	5.0	11.6	51.9	35.3	2.8	61.4	18.7	12.0	5.0	11.6	60.6	3.9	4.6	47.5
100	6.0	1.4	3.2	48.0	33.7	3.5	59.9	13.7	6.0	1.4	3.2	61.7	3.9	4.7	48.5
	9.0	2.9	6.7	49.4	34.3	3.2	60.5	15.3	9.0	2.9	6.7	64.7	4.0	4.8	51.2
110	12.0	4.9	11.4	50.1	34.6	3.1	60.7	16.1	12.0	4.9	11.4	66.3	4.0	4.9	52.7
	6.0	1.4	3.2	45.6	32.7	4.0	59.2	11.5	6.0	1.4	3.2	66.9	4.0	4.9	53.2
120	9.0	2.9	6.6	47.2	33.3	3.7	59.7	12.9	9.0	2.9	6.6	70.0	4.1	5.0	56.0
	12.0	4.9	11.3	48.0	33.7	3.5	59.9	13.7	12.0	4.9	11.3	71.6	4.1	5.1	57.5
130	6.0	1.3	3.1	43.1	31.5	4.5	58.4	9.6	Operation Not Recommended						
	9.0	2.8	6.5	44.8	32.3	4.1	58.9	10.8							
140	12.0	4.8	11.2	45.6	32.6	4.0	59.1	11.5	Operation Not Recommended						
	6.0	1.3	3.0	40.3	30.3	5.1	57.8	7.9							
150	9.0	2.8	6.4	42.1	31.1	4.7	58.2	9.0	Operation Not Recommended						
	12.0	4.7	11.0	43.0	31.5	4.5	58.4	9.5							
160	6.0	1.2	2.9	37.4	29.0	5.8	57.3	6.4	Operation Not Recommended						
	9.0	2.7	6.1	39.3	29.9	5.4	57.6	7.3							
170	12.0	4.6	10.6	40.2	30.3	5.1	57.8	7.8	Operation Not Recommended						

Notes:

- Interpolation is permissible; extrapolation is not.
- All entering air conditions are 80°F (26.6°C) DB and 67°F (19.4°C) WB in cooling, and 70°F (21°C) DB in heating.
- Table does not reflect fan or pump power corrections for AHRI/ISO conditions.
- All performance is based upon the lower voltage of dual voltage rated units.
- Performance stated is at the rated power supply; performance may vary as the power supply varies from the rated.
- Operation below 40°F (4.4°C) is based upon 20% methanol antifreeze solution.
- Operation below 60°F (15.5°C) EWT requires optional insulated water/refrigerant circuit.
- See performance correction tables for operating conditions other than those listed above.
- See Performance Data Selection Notes for operation in the shaded areas.
- Performance capacities shown in thousands of Btuh.
- For unit operation in the shaded area when LWT is below 40°F (4.4°C), antifreeze must be used and the JW3 jumper on the DXM2.5/CXM2 should be clipped. This is due to the potential of the refrigerant temperature being as low as 32°F (0°C) with 40°F (4.4°C) LWT, which may lead to a nuisance cutout due to the activation of the Low Temperature Protection. JW3 should never be clipped for standard range equipment or systems without antifreeze.

Performance Data SR*060 (PSC Blower Motor)

Models:
SR
006-060

2,000 CFM Rated Airflow

EWT °F	WPD			COOLING - EAT 80/67°F					WPD			Heating - EAT 70°F			
	FLOW GPM	PSI	FT	TC	SC	kW	HR	EER	FLOW GPM	PSI	FT	HC	kW	COP	HE
20	Operation Not Recommended								15.0	9.5	22.0	37.2	4.1	2.6	23.1
	7.5	2.6	6.0	66.6	44.5	2.9	76.6	22.6	7.5	2.6	6.0	41.8	4.2	2.9	27.5
30	11.3	5.3	12.3	65.6	43.3	2.8	75.3	23.2	11.3	5.3	12.3	43.5	4.2	3.0	29.2
	15.0	8.5	19.6	64.9	42.5	2.8	74.4	23.4	15.0	8.5	19.6	44.5	4.2	3.1	30.1
40	7.5	2.3	5.3	66.8	45.5	3.2	77.6	21.1	7.5	2.3	5.3	48.6	4.3	3.3	34.0
	11.3	4.7	10.9	66.8	44.9	3.0	77.0	22.2	11.3	4.7	10.9	50.8	4.3	3.4	36.1
50	15.0	7.7	17.8	66.5	44.5	2.9	76.6	22.6	15.0	7.7	17.8	52.1	4.3	3.5	37.2
	7.5	2.1	4.9	66.0	45.6	3.4	77.7	19.2	7.5	2.1	4.9	55.6	4.4	3.7	40.5
60	11.3	4.3	10.0	66.7	45.6	3.2	77.7	20.6	11.3	4.3	10.0	58.3	4.5	3.8	43.0
	15.0	7.2	16.5	66.8	45.5	3.2	77.6	21.2	15.0	7.2	16.5	59.7	4.5	3.9	44.4
70	7.5	2.0	4.6	64.3	45.2	3.8	77.2	17.1	7.5	2.0	4.6	62.5	4.5	4.0	47.0
	11.3	4.1	9.4	65.6	45.6	3.5	77.6	18.6	11.3	4.1	9.4	65.6	4.6	4.2	49.8
80	15.0	6.8	15.6	66.1	45.7	3.4	77.7	19.3	15.0	6.8	15.6	67.2	4.6	4.2	51.4
	7.5	1.9	4.4	62.0	44.3	4.1	76.2	15.0	7.5	1.9	4.4	69.3	4.7	4.3	53.3
90	11.3	3.9	9.0	63.7	44.9	3.9	76.9	16.4	11.3	3.9	9.0	72.6	4.8	4.5	56.3
	15.0	6.5	15.1	64.4	45.2	3.7	77.2	17.2	15.0	6.5	15.1	74.3	4.8	4.5	57.9
100	7.5	1.9	4.3	59.2	43.1	4.6	74.9	12.9	7.5	1.9	4.3	75.7	4.8	4.6	59.3
	11.3	3.8	8.8	61.2	43.9	4.3	75.8	14.3	11.3	3.8	8.8	79.1	4.9	4.7	62.3
110	15.0	6.4	14.8	62.1	44.3	4.1	76.2	15.0	15.0	6.4	14.8	80.8	4.9	4.8	63.9
	7.5	1.8	4.2	56.1	41.7	5.1	73.5	11.0	7.5	1.8	4.2	81.6	5.0	4.8	64.7
120	11.3	3.8	8.7	58.2	42.6	4.8	74.4	12.2	11.3	3.8	8.7	84.8	5.0	4.9	67.6
	15.0	6.3	14.5	59.2	43.1	4.6	74.9	12.9	15.0	6.3	14.5	86.3	5.1	5.0	69.1
130	7.5	1.8	4.1	52.8	40.3	5.7	72.2	9.3	Operation Not Recommended						
	11.3	3.7	8.5	55.0	41.2	5.3	73.1	10.4							
140	15.0	6.2	14.3	56.1	41.7	5.1	73.5	11.0							
	7.5	1.7	4.0	49.6	38.9	6.3	71.2	7.8							
150	11.3	3.6	8.2	51.7	39.8	5.9	71.8	8.7							
	15.0	6.0	13.9	52.7	40.2	5.7	72.2	9.2							
160	7.5	1.6	3.7	46.4	37.8	7.1	70.6	6.5							
	11.3	3.4	7.8	48.4	38.5	6.6	71.0	7.3							
170	15.0	5.8	13.4	49.4	38.9	6.4	71.2	7.7							

Notes:

- Interpolation is permissible; extrapolation is not.
- All entering air conditions are 80°F (26.6°C) DB and 67°F (19.4°C) WB in cooling, and 70°F (21°C) DB in heating.
- Table does not reflect fan or pump power corrections for AHRI/ISO conditions.
- All performance is based upon the lower voltage of dual voltage rated units.
- Performance stated is at the rated power supply; performance may vary as the power supply varies from the rated.
- Operation below 40°F (4.4°C) is based upon 20% methanol antifreeze solution.
- Operation below 60°F (15.5°C) EWT requires optional insulated water/refrigerant circuit.
- See performance correction tables for operating conditions other than those listed above.
- See Performance Data Selection Notes for operation in the shaded areas.
- Performance capacities shown in thousands of Btuh.
- For unit operation in the shaded area when LWT is below 40°F (4.4°C), antifreeze must be used and the JW3 jumper on the DXM2.5/CXM2 should be clipped. This is due to the potential of the refrigerant temperature being as low as 32°F (0°C) with 40°F (4.4°C) LWT, which may lead to a nuisance cutout due to the activation of the Low Temperature Protection. JW3 should never be clipped for standard range equipment or systems without antifreeze.

Performance Data SR*060 (EC Blower Motor)

Models:
SR
006-060

2,000 CFM Rated Airflow

EWT °F	WPD			COOLING - EAT 80/67°F					WPD			Heating - EAT 70°F			
	FLOW GPM	PSI	FT	TC	SC	kW	HR	EER	FLOW GPM	PSI	FT	HC	kW	COP	HE
20	Operation Not Recommended								15.0	9.5	22.0	36.4	3.9	2.7	23.1
	7.5	2.6	6.0	66.6	44.5	2.7	75.8	24.6	7.5	2.6	6.0	41.0	3.9	3.0	27.5
30	11.3	5.3	12.3	65.6	43.3	2.6	74.4	25.4	11.3	5.3	12.3	42.7	4.0	3.2	29.2
	15.0	8.5	19.6	64.9	42.5	2.5	73.6	25.6	15.0	8.5	19.6	43.7	4.0	3.2	30.1
40	7.5	2.3	5.3	66.8	45.5	2.9	76.8	22.9	7.5	2.3	5.3	47.8	4.1	3.5	34.0
	11.3	4.7	10.9	66.8	44.9	2.8	76.2	24.1	11.3	4.7	10.9	50.0	4.1	3.6	36.1
50	15.0	7.7	17.8	66.5	44.5	2.7	75.7	24.7	15.0	7.7	17.8	51.2	4.1	3.7	37.2
	7.5	2.1	4.9	66.0	45.6	3.2	76.9	20.7	7.5	2.1	4.9	54.8	4.2	3.8	40.5
60	11.3	4.3	10.0	66.7	45.6	3.0	76.9	22.2	11.3	4.3	10.0	57.4	4.2	4.0	43.0
	15.0	7.2	16.5	66.8	45.5	2.9	76.8	23.0	15.0	7.2	16.5	58.9	4.3	4.1	44.4
70	7.5	2.0	4.6	64.3	45.2	3.5	76.3	18.3	7.5	2.0	4.6	61.7	4.3	4.2	47.0
	11.3	4.1	9.4	65.6	45.6	3.3	76.8	20.0	11.3	4.1	9.4	64.7	4.4	4.3	49.8
80	15.0	6.8	15.6	66.1	45.7	3.2	76.9	20.8	15.0	6.8	15.6	66.4	4.4	4.4	51.4
	7.5	1.9	4.4	62.0	44.3	3.9	75.3	15.9	7.5	1.9	4.4	68.5	4.4	4.5	53.3
90	11.3	3.9	9.0	63.7	44.9	3.6	76.1	17.5	11.3	3.9	9.0	71.7	4.5	4.7	56.3
	15.0	6.5	15.1	64.4	45.2	3.5	76.4	18.4	15.0	6.5	15.1	73.5	4.6	4.7	57.9
100	7.5	1.9	4.3	59.2	43.1	4.3	74.1	13.6	7.5	1.9	4.3	74.9	4.6	4.8	59.3
	11.3	3.8	8.8	61.2	43.9	4.0	74.9	15.1	11.3	3.8	8.8	78.2	4.7	4.9	62.3
110	15.0	6.4	14.8	62.1	44.3	3.9	75.4	15.9	15.0	6.4	14.8	79.9	4.7	5.0	63.9
	7.5	1.8	4.2	56.1	41.7	4.9	72.7	11.5	7.5	1.8	4.2	80.8	4.7	5.0	64.7
120	11.3	3.8	8.7	58.2	42.6	4.5	73.6	12.9	11.3	3.8	8.7	84.0	4.8	5.1	67.6
	15.0	6.3	14.5	59.2	43.1	4.3	74.1	13.6	15.0	6.3	14.5	85.5	4.8	5.2	69.1
130	7.5	1.8	4.1	52.8	40.3	5.4	71.4	9.7	Operation Not Recommended						
	11.3	3.7	8.5	55.0	41.2	5.1	72.2	10.9	Operation Not Recommended						
140	15.0	6.2	14.3	56.1	41.7	4.9	72.7	11.5	Operation Not Recommended						
	7.5	1.7	4.0	49.6	38.9	6.1	70.4	8.1	Operation Not Recommended						
150	11.3	3.6	8.2	51.7	39.8	5.7	71.0	9.1	Operation Not Recommended						
	15.0	6.0	13.9	52.7	40.2	5.5	71.4	9.6	Operation Not Recommended						
160	7.5	1.6	3.7	46.4	37.8	6.9	69.8	6.8	Operation Not Recommended						
	11.3	3.4	7.8	48.4	38.5	6.4	70.1	7.6	Operation Not Recommended						
170	15.0	5.8	13.4	49.4	38.9	6.1	70.4	8.0	Operation Not Recommended						

Notes:

- Interpolation is permissible; extrapolation is not.
- All entering air conditions are 80°F (26.6°C) DB and 67°F (19.4°C) WB in cooling, and 70°F (21°C) DB in heating.
- Table does not reflect fan or pump power corrections for AHRI/ISO conditions.
- All performance is based upon the lower voltage of dual voltage rated units.
- Performance stated is at the rated power supply; performance may vary as the power supply varies from the rated.
- Operation below 40°F (4.4°C) is based upon 20% methanol antifreeze solution.
- Operation below 60°F (15.5°C) EWT requires optional insulated water/refrigerant circuit.
- See performance correction tables for operating conditions other than those listed above.
- See Performance Data Selection Notes for operation in the shaded areas.
- Performance capacities shown in thousands of Btuh.
- For unit operation in the shaded area when LWT is below 40°F (4.4°C), antifreeze must be used and the JW3 jumper on the DXM2.5/CXM2 should be clipped. This is due to the potential of the refrigerant temperature being as low as 32°F (0°C) with 40°F (4.4°C) LWT, which may lead to a nuisance cutout due to the activation of the Low Temperature Protection. JW3 should never be clipped for standard range equipment or systems without antifreeze.

Performance Data SR024 Hybrid (EC Blower Motor)

Models:
SR
006-060

800 CFM Rated Airflow

EWT °F	WPD			Heating - EAT 70°F					
	FLOW GPM	PSI	FT	Capacity (Btuh)	kW	LAT (°F)	DT Air (°F)	DT water (°F)	T water out (°F)
90	3.00	1.0	2.3	11,200	3.28	82	12	7	83
	4.50	2.0	4.6	12,700	3.72	84	14	5	85
	6.00	3.0	6.9	13,400	3.93	85	15	4	86
95	3.00	1.0	2.3	14,100	4.13	86	16	9	86
	4.50	2.0	4.6	15,900	4.66	88	18	7	88
	6.00	3.0	6.9	16,800	4.92	89	19	5	90
100	3.00	1.0	2.3	17,000	4.98	89	19	11	89
	4.50	2.0	4.6	19,200	5.63	91	21	8	92
	6.00	3.0	6.9	20,200	5.92	93	23	6	94
105	3.00	1.0	2.3	20,000	5.86	92	22	13	92
	4.50	2.0	4.6	22,400	6.56	95	25	10	95
	6.00	3.0	6.9	23,600	6.92	96	26	7	98
110	3.00	1.0	2.3	23,000	6.74	96	26	15	95
	4.50	2.0	4.6	25,700	7.53	99	29	11	99
	6.00	3.0	6.9	27,000	7.91	100	30	9	101
115	3.00	1.0	2.3	26,000	7.62	99	29	17	98
	4.50	2.0	4.6	29,000	8.50	103	33	13	102
	6.00	3.0	6.9	30,500	8.94	104	34	10	105
120	3.00	1.0	2.3	29,000	8.50	103	33	19	101
	4.50	2.0	4.6	32,300	9.47	106	36	14	106
	6.00	3.0	6.9	34,000	9.96	108	38	11	109

- Interpolation is permissible; extrapolation is not.
- All entering air conditions are 80°F (26.6°C) DB and 67°F (19.4°C) WB in cooling, and 70°F (21°C) DB in heating.
- Table does not reflect fan or pump power corrections for AHRI/ISO conditions.
- All performance is based upon the lower voltage of dual voltage rated units.
- Performance stated is at the rated power supply; performance may vary as the power supply varies from the rated.
- Operation below 40°F (4.4°C) is based upon 20% methanol antifreeze solution.
- Operation below 60°F (15.5°C) EWT requires optional insulated water/refrigerant circuit.
- See performance correction tables for operating conditions other than those listed above.
- See Performance Data Selection Notes for operation in the shaded areas.
- Performance capacities shown in thousands of Btuh.

Performance Data SR030 Hybrid (EC Blower Motor)

Models:
SR
006-060

1,000 CFM Rated Airflow

EWT °F	WPD			Heating - EAT 70°F					
	FLOW GPM	PSI	FT	Capacity (Btuh)	kW	LAT (°F)	DT Air (°F)	DT water (°F)	T water out (°F)
90	3.75	2.0	4.6	13,700	4.02	82	12	7	83
	5.63	3.0	6.9	15,300	4.48	83	13	5	85
	7.50	4.0	9.2	16,100	4.72	84	14	4	86
95	3.75	2.0	4.6	17,300	5.07	85	15	9	86
	5.63	3.0	6.9	19,200	5.63	87	17	6	89
	7.50	4.0	9.2	20,200	5.92	88	18	5	90
100	3.75	2.0	4.6	20,800	6.10	89	19	11	89
	5.63	3.0	6.9	23,100	6.77	91	21	8	92
	7.50	4.0	9.2	24,300	7.12	92	22	6	94
105	3.75	2.0	4.6	24,400	7.15	92	22	13	92
	5.63	3.0	6.9	27,100	7.94	94	24	9	96
	7.50	4.0	9.2	28,400	8.32	95	25	7	98
110	3.75	2.0	4.6	28,000	8.21	95	25	15	95
	5.63	3.0	6.9	31,000	9.09	98	28	11	99
	7.50	4.0	9.2	32,500	9.52	99	29	8	102
115	3.75	2.0	4.6	31,600	9.26	98	28	17	98
	5.63	3.0	6.9	35,000	10.26	101	31	12	103
	7.50	4.0	9.2	36,700	10.76	103	33	9	106
120	3.75	2.0	4.6	35,200	10.32	102	32	19	101
	5.63	3.0	6.9	39,000	11.43	105	35	13	107
	7.50	4.0	9.2	40,800	11.96	107	Target	Target	110

- Interpolation is permissible; extrapolation is not.
- All entering air conditions are 80°F (26.6°C) DB and 67°F (19.4°C) WB in cooling, and 70°F (21°C) DB in heating.
- Table does not reflect fan or pump power corrections for AHRI/ISO conditions.
- All performance is based upon the lower voltage of dual voltage rated units.
- Performance stated is at the rated power supply; performance may vary as the power supply varies from the rated.
- Operation below 40°F (4.4°C) is based upon 20% methanol antifreeze solution.
- Operation below 60°F (15.5°C) EWT requires optional insulated water/refrigerant circuit.
- See performance correction tables for operating conditions other than those listed above.
- See Performance Data Selection Notes for operation in the shaded areas.
- Performance capacities shown in thousands of Btuh.

Performance Data SR036 Hybrid (EC Blower Motor)

Models:
SR
006-060

1,150 CFM Rated Airflow

EWT °F	WPD			Heating - EAT 70°F					
	FLOW GPM	PSI	FT	Capacity (Btuh)	kW	LAT (°F)	DT Air (°F)	DT water (°F)	T water out (°F)
90	4.50	1.0	2.3	17,500	5.13	83	13	7	83
	6.75	2.0	4.6	19,700	5.77	85	15	5	85
	9.00	3.0	6.9	20,700	6.07	86	16	4	86
95	4.50	1.0	2.3	22,000	6.45	87	17	9	86
	6.75	2.0	4.6	24,700	7.24	89	19	7	88
	9.00	3.0	6.9	26,000	7.62	90	20	5	90
100	4.50	1.0	2.3	26,500	7.77	91	21	11	89
	6.75	2.0	4.6	29,700	8.70	93	23	8	92
	9.00	3.0	6.9	31,300	9.17	94	24	7	93
105	4.50	1.0	2.3	31,100	9.11	94	24	13	92
	6.75	2.0	4.6	34,700	10.17	97	27	10	95
	9.00	3.0	6.9	36,600	10.73	99	29	8	97
110	4.50	1.0	2.3	35,700	10.46	98	28	16	94
	6.75	2.0	4.6	39,800	11.66	101	31	11	99
	9.00	3.0	6.9	41,900	12.28	103	33	9	101
115	4.50	1.0	2.3	40,300	11.81	101	31	18	97
	6.75	2.0	4.6	44,800	13.13	105	35	13	102
	9.00	3.0	6.9	47,200	13.83	107	37	10	105
120	4.50	1.0	2.3	44,800	13.13	105	35	20	100
	6.75	2.0	4.6	49,900	14.62	109	39	14	106
	9.00	3.0	6.9	52,500	15.39	111	41	11	109

- Interpolation is permissible; extrapolation is not.
- All entering air conditions are 80°F (26.6°C) DB and 67°F (19.4°C) WB in cooling, and 70°F (21°C) DB in heating.
- Table does not reflect fan or pump power corrections for AHRI/ISO conditions.
- All performance is based upon the lower voltage of dual voltage rated units.
- Performance stated is at the rated power supply; performance may vary as the power supply varies from the rated.
- Operation below 40°F (4.4°C) is based upon 20% methanol antifreeze solution.
- Operation below 60°F (15.5°C) EWT requires optional insulated water/refrigerant circuit.
- See performance correction tables for operating conditions other than those listed above.
- See Performance Data Selection Notes for operation in the shaded areas.
- Performance capacities shown in thousands of Btuh.

Performance Data SR042 Hybrid (EC Blower Motor)

Models:
SR
006-060

1,400 CFM Rated Airflow

EWT °F	WPD			Heating - EAT 70°F					
	FLOW GPM	PSI	FT	Capacity (Btuh)	kW	LAT (°F)	DT Air (°F)	DT water (°F)	T water out (°F)
90	5.25	1.0	2.3	20,600	6.04	83	13	7	83
	7.88	2.0	4.6	23,100	6.77	85	15	5	85
	10.50	4.0	9.2	24,400	7.15	85	15	4	86
95	5.25	1.0	2.3	25,900	7.59	86	16	9	86
	7.88	2.0	4.6	29,000	8.50	88	18	7	88
	10.50	4.0	9.2	30,500	8.94	89	19	5	90
100	5.25	1.0	2.3	31,200	9.14	90	20	11	89
	7.88	2.0	4.6	34,900	10.23	92	22	8	92
	10.50	4.0	9.2	36,700	10.76	93	23	7	93
105	5.25	1.0	2.3	36,500	10.70	93	23	14	91
	7.88	2.0	4.6	40,800	11.96	96	26	10	95
	10.50	4.0	9.2	43,000	12.60	98	28	8	97
110	5.25	1.0	2.3	41,900	12.28	97	27	16	94
	7.88	2.0	4.6	46,700	13.69	100	30	11	99
	10.50	4.0	9.2	49,200	14.42	102	32	9	101
115	5.25	1.0	2.3	47,200	13.83	100	30	18	97
	7.88	2.0	4.6	52,700	15.44	104	34	13	102
	10.50	4.0	9.2	55,500	16.27	106	36	10	105
120	5.25	1.0	2.3	52,600	15.42	104	34	20	100
	7.88	2.0	4.6	58,700	17.20	108	38	15	105
	10.50	4.0	9.2	61,700	18.08	110	40	11	109

- Interpolation is permissible; extrapolation is not.
- All entering air conditions are 80°F (26.6°C) DB and 67°F (19.4°C) WB in cooling, and 70°F (21°C) DB in heating.
- Table does not reflect fan or pump power corrections for AHRI/ISO conditions.
- All performance is based upon the lower voltage of dual voltage rated units.
- Performance stated is at the rated power supply; performance may vary as the power supply varies from the rated.
- Operation below 40°F (4.4°C) is based upon 20% methanol antifreeze solution.
- Operation below 60°F (15.5°C) EWT requires optional insulated water/refrigerant circuit.
- See performance correction tables for operating conditions other than those listed above.
- See Performance Data Selection Notes for operation in the shaded areas.
- Performance capacities shown in thousands of Btuh.

Performance Data SR048 Hybrid (EC Blower Motor)

Models:
SR
006-060

1,500 CFM Rated Airflow

EWT °F	WPD			Heating - EAT 70°F					
	FLOW GPM	PSI	FT	Capacity (Btuh)	kW	LAT (°F)	DT Air (°F)	DT water (°F)	T water out (°F)
90	6.00	2.0	4.6	23,100	6.77	84	14	7	83
	9.00	3.0	6.9	25,400	7.44	85	15	5	85
	12.00	5.0	11.5	26,400	7.74	86	16	4	86
95	6.00	2.0	4.6	29,000	8.50	87	17	9	86
	9.00	3.0	6.9	31,800	9.32	89	19	7	88
	12.00	5.0	11.5	33,000	9.67	90	20	5	90
100	6.00	2.0	4.6	34,900	10.23	91	21	11	89
	9.00	3.0	6.9	38,200	11.20	93	23	8	92
	12.00	5.0	11.5	39,700	11.63	94	24	6	94
105	6.00	2.0	4.6	40,800	11.96	94	24	13	92
	9.00	3.0	6.9	44,700	13.10	97	27	9	96
	12.00	5.0	11.5	46,400	13.60	98	28	7	98
110	6.00	2.0	4.6	46,700	13.69	98	28	15	95
	9.00	3.0	6.9	51,100	14.98	101	31	11	99
	12.00	5.0	11.5	53,100	15.56	102	32	8	102
115	6.00	2.0	4.6	52,600	15.42	102	32	17	98
	9.00	3.0	6.9	57,600	16.88	105	35	12	103
	12.00	5.0	11.5	59,800	17.53	106	36	10	105
120	6.00	2.0	4.6	58,600	17.17	105	35	19	101
	9.00	3.0	6.9	64,100	18.79	109	39	14	106
	12.00	5.0	11.5	66,500	19.49	110	40	11	109

- Interpolation is permissible; extrapolation is not.
- All entering air conditions are 80°F (26.6°C) DB and 67°F (19.4°C) WB in cooling, and 70°F (21°C) DB in heating.
- Table does not reflect fan or pump power corrections for AHRI/ISO conditions.
- All performance is based upon the lower voltage of dual voltage rated units.
- Performance stated is at the rated power supply; performance may vary as the power supply varies from the rated.
- Operation below 40°F (4.4°C) is based upon 20% methanol antifreeze solution.
- Operation below 60°F (15.5°C) EWT requires optional insulated water/refrigerant circuit.
- See performance correction tables for operating conditions other than those listed above.
- See Performance Data Selection Notes for operation in the shaded areas.
- Performance capacities shown in thousands of Btuh.

Performance Data SR060 Hybrid (EC Blower Motor)

Models:
SR
006-060

1,950 CFM Rated Airflow

EWT °F	WPD			Heating - EAT 70°F					
	FLOW GPM	PSI	FT	Capacity (Btuh)	kW	LAT (°F)	DT Air (°F)	DT water (°F)	T water out (°F)
90	7.50	2.0	4.6	28,900	8.47	83	13	7	83
	11.25	5.0	11.5	31,600	9.26	84	14	5	85
	15.00	8.0	18.5	32,800	9.61	85	15	4	86
95	7.50	2.0	4.6	36,200	10.61	86	16	9	86
	11.25	5.0	11.5	39,600	11.61	88	18	7	88
	15.00	8.0	18.5	41,100	12.05	89	19	5	90
100	7.50	2.0	4.6	43,600	12.78	90	20	11	89
	11.25	5.0	11.5	47,600	13.95	92	22	8	92
	15.00	8.0	18.5	49,400	14.48	93	23	6	94
105	7.50	2.0	4.6	51,000	14.95	93	23	13	92
	11.25	5.0	11.5	55,700	16.32	96	26	9	96
	15.00	8.0	18.5	57,700	16.91	96	26	7	98
110	7.50	2.0	4.6	58,400	17.12	97	27	15	95
	11.25	5.0	11.5	63,800	18.70	99	29	11	99
	15.00	8.0	18.5	66,100	19.37	100	30	8	102
115	7.50	2.0	4.6	65,800	19.28	100	30	17	98
	11.25	5.0	11.5	71,800	21.04	103	33	12	103
	15.00	8.0	18.5	74,500	21.83	104	34	10	105
120	7.50	2.0	4.6	73,200	21.45	104	34	19	101
	11.25	5.0	11.5	80,000	23.45	107	37	14	106
	15.00	8.0	18.5	82,800	24.27	108	38	11	109

- Interpolation is permissible; extrapolation is not.
- All entering air conditions are 80°F (26.6°C) DB and 67°F (19.4°C) WB in cooling, and 70°F (21°C) DB in heating.
- Table does not reflect fan or pump power corrections for AHRI/ISO conditions.
- All performance is based upon the lower voltage of dual voltage rated units.
- Performance stated is at the rated power supply; performance may vary as the power supply varies from the rated.
- Operation below 40°F (4.4°C) is based upon 20% methanol antifreeze solution.
- Operation below 60°F (15.5°C) EWT requires optional insulated water/refrigerant circuit.
- See performance correction tables for operating conditions other than those listed above.
- See Performance Data Selection Notes for operation in the shaded areas.
- Performance capacities shown in thousands of Btuh.

CV EC MOTOR ADVANTAGE

A major benefit of the CV EC motor over other blower motor types is its ability to adjust airflow remotely through the iGate 2 web portal/mobile app or directly at the unit with a communicating diagnostic service tool. Airflow levels can be adjusted in increments of 25 CFM from the unit's minimum and maximum CFM range (see the CV EC motor configuration table for details).

Table 1: CV EC Blower Motor Limits

Size	Max ESP (in. wg)	Fan Motor (hp)	Airflow Range	Cooling Mode	Heating Mode	Dehumid Mode	Fan Only
6	0.9	1/8	Minimum	150	150	150	150
	1.0		Default	275	275	150	275
	1.0		Maximum	275	275	225	275
9	0.9	1/8	Minimum	225	225	225	225
	0.9		Default	345	345	225	345
	0.9		Maximum	375	375	325	375
12	0.8	1/4	Minimum	300	300	300	300
	0.8		Default	400	400	300	400
	0.9		Maximum	415	415	380	415
15	0.8	1/3	Minimum	375	375	375	375
	1.0		Default	525	525	375	525
	1.0		Maximum	625	625	600	625
18	0.8	1/3	Minimum	450	450	450	450
	0.9		Default	630	630	450	630
	0.9		Maximum	750	750	600	750
24	0.75	1/2	Minimum	600	600	600	300
			Default	750	750	650	350
			Maximum	850	850	800	850
30	0.5	1/2	Minimum	750	750	750	375
			Default	925	925	800	425
			Maximum	1,050	1,050	1,000	1,050
36	0.6	3/4	Minimum	900	900	900	450
			Default	1,125	1,125	975	525
			Maximum	1,275	1,275	1,200	1,275
42	0.6	3/4	Minimum	1,050	1,050	1,050	525
			Default	1,300	1,300	1,125	600
			Maximum	1,475	1,475	1,400	1,475
48	0.6	3/4	Minimum	1,200	1,200	1,200	600
			Default	1,500	1,500	1,300	700
			Maximum	1,700	1,700	1,600	1,700
60	0.75	1	Minimum	1,500	1,500	1,500	750
			Default	1,875	1,875	1,625	875
			Maximum	2,125	2,125	2,000	2,125

- Airflow is controlled within ±5% up to Max ESP shown with wet coil and standard 1-inch fiberglass air filter.
- Performance shown is with wet coil and factory air filters.

Standard Correction Tables

Models:
SR
006-060

Cooling Corrections

Full Load Cooling Corrections									
Ent Air WB F	Total Clg Cap	Sens Clg Cap Multipliers- Entering DB F						Power	Heat of Rejection
		65	70	75	80	85	90		
50	0.708	1.158	*	*	*	*	*	1.004	0.775
55	0.794	0.895	1.101	*	*	*	*	1.003	0.852
60	0.880	0.686	0.891	1.097	*	*	*	1.002	0.914
65	0.966		0.680	0.884	1.086	1.293	*	1.000	0.975
67	1.000		0.596	0.799	1.000	1.207	1.410	1.000	1.000
70	1.052			0.672	0.871	1.077	1.280	0.999	1.037
75	1.138				0.657	0.862	1.063	0.998	1.098

* Sensible Capacity equals Total Capacity.
AHRI/ISO/ASHRAE 13256-1 uses entering air conditions of Cooling - 80.6°F DB/ 66.2°F WB, and Heating - 68°F DB/ 59°F WB entering air temperature.
Entering DB temperature range is based on operating limits, not on commission limits.
Cooling air corrections based on rated airflow.

Heating Corrections

Full EAT Heating Corrections			
Ent Air DB °F	Heating Capacity	Power	Heat of Extraction
50	1.022	0.775	1.086
55	1.016	0.841	1.060
60	1.011	0.894	1.040
65	1.005	0.947	1.020
70	1.000	1.000	1.000
75	0.995	1.053	0.980
80	0.989	1.106	0.960

Heating air corrections based on rated airflow.

Airflow Correction Table

Full Airflow Corrections								
Airflow % of Rated	Heating			Cooling				
	Heating Capacity	Heating Power	Heat of Extraction	Total Capacity	Sensible Capacity	Sens/Total Ratio	Power	Heat of Rejection
80	0.979	1.044	0.969	0.970	0.904	0.932	0.968	0.974
85	0.984	1.033	0.977	0.977	0.928	0.950	0.976	0.980
90	0.989	1.022	0.985	0.985	0.952	0.967	0.984	0.987
95	0.995	1.011	0.992	0.992	0.976	0.983	0.992	0.993
100	1.000	1.000	1.000	1.000	1.000	1.000	1.000	1.000
105	1.005	0.989	1.008	1.008	1.024	1.016	1.008	1.007
110	1.011	0.978	1.015	1.015	1.048	1.032	1.016	1.013

Cooling and heating air corrections based on rated airflow.

Hybrid Correction Tables

Models:
SR
006-060

Entering Air Corrections

Ent Air WB F	Heating Cap
45	1.70
50	1.56
55	1.42
60	1.28
65	1.14
68	1.05
70	1.00
75	0.86
80	0.72

Airflow Corrections

% of Rated CFM	Heating Capacity
75	0.83
81.25	0.87
87.5	0.92
93.75	0.96
100	1.00
106.25	1.04
112.5	1.08
118.75	1.11
125	1.15

Cooling and heating air corrections based on rated airflow.

WSE Correction Tables

Models:
SR
006-060

Entering Air Correction Table

Full Load Cooling Corrections 400 CFM per Ton										
Ent Air WB °F	Total Clg Cap	Sensible Cooling Capacity Multipliers - Entering DB °F								
		65	70	75	80	80.6	85	90	95	100
50	0.352	*	*	*	*	*	*	*	*	*
55	0.507	0.615	0.766	*	*	*	*	*	*	*
60	0.693	0.542	0.74	0.912	*	*	*	*	*	*
65	0.906		0.623	0.842	1.035	1.057	*	*	*	*
66.2	0.962		0.582	0.811	1.015	1.039	1.195	*	*	*
67	1.000		0.551	0.788	1	1.024	1.187	*	*	*
70	1.148			0.681	0.92	0.947	1.135	1.324	*	*
75	1.420				0.715	0.748	0.976	1.211	1.421	1.421

- * Sensible capacity equals total capacity
- AHRI/ISO/ASHRAE 13256-1 uses entering air conditions of Cooling - 80.6°F DB/ 66.2°F WB, and Heating - 68°F DB/ 59°F WB entering air temperature.

Airflow Correction Table

Airflow % Nominal Capacity	Cooling Corrections	
	Sensible Capacity	Sens/Total Ratio
75	0.834	0.940
81.25	0.878	0.957
87.5	0.921	0.972
93.75	0.962	0.987
100	1.000	1.000
106.25	1.036	1.012
112.5	1.071	1.023
118.75	1.103	1.033
125	1.133	1.042

ClimateMaster works continually to improve its products. As a result, the design and specifications of each product at the time of order may be changed without notice and may not be as described herein. Please contact ClimateMaster's Customer Service Department at 800-299-9747 for specific information on the current design and specifications. Statements and other information contained herein are not express warranties and do not form the basis of any bargain between the parties, but are merely ClimateMaster's opinion or commendation of its products. The latest version of this document is available at www.climate-master.com. Engineered and assembled in the USA. © ClimateMaster, Inc. All Rights Reserved 2024

Antifreeze Correction Table

Models:
SR
006-060

EWT (°F)	Antifreeze Type	Antifreeze %	Cooling			Heating		WPD
			Total Cap	Sensible Cap	Watts	Total Cap	Watts	
90	Water	0%	1.000	1.000	1.000	1.000	1.000	1.000
	Ethanol	5%	0.998	0.998	1.002	0.996	0.999	1.025
		10%	0.996	0.996	1.003	0.991	0.997	1.048
		15%	0.994	0.994	1.005	0.987	0.996	1.098
		20%	0.991	0.991	1.006	0.982	0.994	1.142
		25%	0.986	0.986	1.009	0.972	0.991	1.207
		30%	0.981	0.981	1.012	0.962	0.988	1.265
		35%	0.977	0.977	1.015	0.953	0.985	1.312
		40%	0.972	0.972	1.018	0.943	0.982	1.370
		45%	0.966	0.966	1.023	0.931	0.978	1.431
		50%	0.959	0.959	1.027	0.918	0.974	1.494
	Ethylene Glycol	5%	0.998	0.998	1.002	0.996	0.999	1.021
		10%	0.996	0.996	1.003	0.991	0.997	1.040
		15%	0.994	0.994	1.004	0.987	0.996	1.079
		20%	0.991	0.991	1.005	0.982	0.995	1.114
		25%	0.988	0.988	1.008	0.976	0.993	1.146
		30%	0.985	0.985	1.010	0.969	0.990	1.175
		35%	0.982	0.982	1.012	0.963	0.988	1.208
		40%	0.979	0.979	1.014	0.956	0.986	1.243
		45%	0.976	0.976	1.016	0.950	0.984	1.278
		50%	0.972	0.972	1.018	0.943	0.982	1.314
	Methanol	5%	0.997	0.997	1.002	0.993	0.998	1.039
		10%	0.993	0.993	1.004	0.986	0.996	1.075
		15%	0.990	0.990	1.007	0.979	0.994	1.116
		20%	0.986	0.986	1.009	0.972	0.991	1.154
		25%	0.982	0.982	1.012	0.964	0.989	1.189
		30%	0.978	0.978	1.014	0.955	0.986	1.221
		35%	0.974	0.974	1.017	0.947	0.984	1.267
		40%	0.970	0.970	1.020	0.939	0.981	1.310
		45%	0.966	0.966	1.023	0.930	0.978	1.353
		50%	0.961	0.961	1.026	0.920	0.975	1.398
	Propylene Glycol	5%	0.995	0.995	1.003	0.990	0.997	1.065
		10%	0.990	0.990	1.006	0.980	0.994	1.119
		15%	0.986	0.986	1.009	0.971	0.991	1.152
		20%	0.981	0.981	1.012	0.962	0.988	1.182
		25%	0.978	0.978	1.014	0.956	0.986	1.227
		30%	0.975	0.975	1.016	0.950	0.984	1.267
		35%	0.972	0.972	1.018	0.944	0.982	1.312
		40%	0.969	0.969	1.020	0.938	0.980	1.356
		45%	0.965	0.965	1.023	0.929	0.977	1.402
		50%	0.960	0.960	1.026	0.919	0.974	1.450

Table continued on next page

ClimateMaster works continually to improve its products. As a result, the design and specifications of each product at the time of order may be changed without notice and may not be as described herein. Please contact ClimateMaster's Customer Service Department at 800-299-9747 for specific information on the current design and specifications. Statements and other information contained herein are not express warranties and do not form the basis of any bargain between the parties, but are merely ClimateMaster's opinion or commendation of its products. The latest version of this document is available at www.climatemaster.com. Engineered and assembled in the USA. © ClimateMaster, Inc. All Rights Reserved 2024

Antifreeze Correction Table

Models:
SR
006-060

Table continued from previous page

EWT (°F)	Antifreeze Type	Antifreeze %	Cooling			Heating		WPD
			Total Cap	Sensible Cap	Watts	Total Cap	Watts	
30	Water	0%	1.000	1.000	1.000	1.000	1.000	1.000
	Ethanol	5%	0.991	0.991	1.006	0.981	0.994	1.140
		10%	0.981	0.981	1.012	0.961	0.988	1.242
		15%	0.973	0.973	1.018	0.944	0.983	1.295
		20%	0.964	0.964	1.024	0.927	0.977	1.343
		25%	0.959	0.959	1.028	0.917	0.974	1.363
		30%	0.954	0.954	1.031	0.907	0.970	1.383
		35%	0.949	0.949	1.035	0.897	0.967	1.468
		40%	0.944	0.944	1.038	0.887	0.964	1.523
		45%	0.940	0.940	1.041	0.880	0.962	1.580
	50%	0.936	0.936	1.043	0.872	0.959	1.639	
	Ethylene Glycol	5%	0.997	0.997	1.002	0.993	0.998	1.040
		10%	0.993	0.993	1.004	0.986	0.996	1.075
		15%	0.990	0.990	1.006	0.980	0.994	1.122
		20%	0.987	0.987	1.008	0.973	0.992	1.163
		25%	0.983	0.983	1.011	0.966	0.990	1.195
		30%	0.979	0.979	1.013	0.958	0.987	1.225
		35%	0.976	0.976	1.016	0.951	0.985	1.279
		40%	0.972	0.972	1.018	0.943	0.982	1.324
		45%	0.969	0.969	1.021	0.937	0.980	1.371
	50%	0.966	0.966	1.023	0.930	0.978	1.419	
	Methanol	5%	0.995	0.995	1.004	0.989	0.997	1.069
		10%	0.989	0.989	1.007	0.978	0.993	1.127
		15%	0.984	0.984	1.011	0.968	0.990	1.164
		20%	0.979	0.979	1.014	0.957	0.986	1.197
		25%	0.975	0.975	1.017	0.949	0.984	1.216
		30%	0.971	0.971	1.019	0.941	0.981	1.235
		35%	0.967	0.967	1.022	0.933	0.979	1.286
		40%	0.963	0.963	1.025	0.924	0.976	1.323
		45%	0.959	0.959	1.028	0.917	0.974	1.360
	50%	0.955	0.955	1.030	0.910	0.971	1.399	
	Propylene Glycol	5%	0.995	0.995	1.004	0.989	0.997	1.071
		10%	0.989	0.989	1.007	0.978	0.993	1.130
		15%	0.985	0.985	1.010	0.968	0.990	1.206
		20%	0.980	0.980	1.013	0.958	0.987	1.270
		25%	0.974	0.974	1.017	0.947	0.983	1.359
		30%	0.968	0.968	1.021	0.935	0.979	1.433
		35%	0.963	0.963	1.025	0.924	0.976	1.522
		40%	0.957	0.957	1.029	0.913	0.972	1.614
		45%	0.949	0.949	1.034	0.898	0.967	1.712
	50%	0.941	0.941	1.039	0.882	0.962	1.816	

ClimateMaster works continually to improve its products. As a result, the design and specifications of each product at the time of order may be changed without notice and may not be as described herein. Please contact ClimateMaster's Customer Service Department at 800-299-9747 for specific information on the current design and specifications. Statements and other information contained herein are not express warranties and do not form the basis of any bargain between the parties, but are merely ClimateMaster's opinion or commendation of its products. The latest version of this document is available at www.climatemaster.com. Engineered and assembled in the USA. © ClimateMaster, Inc. All Rights Reserved 2024

Correction Tables: Water Pressure Drop Adder for Options

Models:
SR
006-060

Motorized Water Valve Option Corrections

Model	GPM	MWV Pressure Drop (Adders)				
		CV	Close Off	MOPD	PSI	FT
SR*006	1.75	4.9	125	300	0.1	0.3
	1.31				0.1	0.2
	0.88				0.0	0.1
SR*009	2.5	4.9	125	300	0.3	0.6
	1.88				0.1	0.3
	1.25				0.1	0.2
SR*012	3	4.9	125	300	0.4	0.9
	2.25				0.2	0.5
	1.50				0.1	0.2
SR*015	4	4.9	125	300	0.7	1.5
	3.00				0.4	0.9
	2.00				0.2	0.4
SR*018	4.5	4.9	125	300	0.8	1.9
	3.38				0.5	1.1
	2.25				0.2	0.5
SR*024	6	4.9	125	300	1.5	3.5
	4.5				0.8	1.9
	3				0.4	0.9
SR*030	7.5	10.3	125	300	0.5	1.2
	5.6				0.3	0.7
	3.8				0.1	0.3
SR*036	9	10.3	125	300	0.8	1.8
	6.8				0.4	1.0
	4.5				0.2	0.4
SR*042	10.5	10.3	125	300	1.0	2.4
	7.9				0.6	1.4
	5.2				0.3	0.6
SR*048	12	10.3	125	300	1.4	3.1
	9				0.8	1.8
	6				0.3	0.8
SR*060	15	8.9	125	300	2.8	6.6
	11.3				1.6	3.7
	7.5				0.7	1.6

ClimateMaster works continually to improve its products. As a result, the design and specifications of each product at the time of order may be changed without notice and may not be as described herein. Please contact ClimateMaster's Customer Service Department at 800-299-9747 for specific information on the current design and specifications. Statements and other information contained herein are not express warranties and do not form the basis of any bargain between the parties, but are merely ClimateMaster's opinion or commendation of its products. The latest version of this document is available at www.climatemaster.com. Engineered and assembled in the USA. © ClimateMaster, Inc. All Rights Reserved 2024

Correction Tables: Pressure Drop Adder for Options

Models:
SR
006-060

WSE Option Airside Pressure Drop

Model		Airside PD Adder (in.wg.) at CFM				
SR036	Coil	900	1050	1200	1350	1500
	Dry	0.07	0.09	0.11	0.13	0.16
	Wet	0.10	0.13	0.16	0.18	0.21
SR042	Coil	1050	1225	1400	1575	1750
	Dry	0.09	0.12	0.14	0.17	0.21
	Wet	0.13	0.16	0.19	0.22	0.25
SR048	Coil	1200	1400	1600	1800	2000
	Dry	0.06	0.08	0.10	0.12	0.15
	Wet	0.10	0.12	0.15	0.18	0.21
SR060	Coil	1500	1750	2000	2250	2500
	Dry	0.09	0.12	0.15	0.17	0.20
	Wet	0.14	0.17	0.21	0.24	0.28

- Add WSE to your duct static to get total ESP.
- Check blower performance table to ensure you meet CFM requirement and are within operational range.

Blower Performance SR*006

Models:
SR
006-060

Model	Rated CFM	Min CFM	Motor Type	Speed Tap	External Static Pressure (in. wg)															
					0.1	0.2	0.3	0.4	0.5	0.6	0.7	0.8	0.9	1.0						
SR006	275	150	PSC	Low	Power (W)	72	69	65	61	57	Operation Not Recommended									
					CFM	238	218	196	170	142										
				Medium	Power (W)	81	77	73	68	63						58				
					CFM	261	242	220	193	163						129				
				High	Power (W)	103	98	93	88	82						75	68			
					CFM	326	306	282	253	219						181	139			
	275	150	CTEC	1	Power (W)	22	24	25	28	30	Operation Not Recommended									
					CFM	225	207	187	169	150										
				2	Power (W)	Operation Not Recommended			34	37						39	42	44	48	51
					CFM	Operation Not Recommended			233	217						201	185	173	164	150
				3	Power (W)	Operation Not Recommended			43	45						48	51	54	58	61
					CFM	Operation Not Recommended			241	227						212	200	188	179	168
				4	Power (W)	Operation Not Recommended										55	58	61	65	67
					CFM	Operation Not Recommended										240	227	216	205	193
	275	150	CV EC	Minimum CFM	Power (W)	16	21	27	40	36	41	46	52	59	Operation Not Recommended					
					CFM	150	150	150	150	150	150	150	150	150						
				Default CFM	Power (W)	29	35	41	47	53	60	67	76	81	77					
					CFM	225	225	225	225	225	225	225	225	225	255					
Maximum CFM				Power (W)	35	41	47	53	60	67	76	84	88	78						
				CFM	250	250	250	250	250	250	250	250	250	250						

- Blower performance data is based on the lowest nameplate voltage setting.
- Blower performance is based on a wet coil with clean 1-inch filter.
- Blower performance is based on operating conditions of 80°F DB and 67°F WB.
- CFM Tolerance is ±7%.
- Cells in grey - option not available.
- The maximum allowable altitude of installation for this product is 6,561 ft (2,000 m).

Blower Performance SR*009

Models:
SR
006-060

Model	Rated CFM	Min CFM	Motor Type	Speed Tap	External Static Pressure (in. wg)																																																							
					0.1	0.2	0.3	0.4	0.5	0.6	0.7	0.8	0.9	1.0																																														
SR009	345	225	PSC	Low	Power (W)	Operation Not Recommended																																																						
					CFM											340	322	300	260																																									
				Medium	Power (W)											Operation Not Recommended																																												
					CFM																					390	360	320	290	260																														
				High	Power (W)																					Operation Not Recommended																																		
					CFM																															410	380	350	320	280																				
	345	225	CTEC	1	Power (W)																															40	42	44	47	49																				
					CFM																															294	278	259	245	230																				
				2	Power (W)																															67	70	73	74	79						82	85	88	90	85										
					CFM																															370	357	343	326	318						302	291	278	265	235										
				3	Power (W)																																			86						88	91	95	98	101	96	90								
					CFM																																			370						358	346	334	322	307	280	247								
				4	Power (W)																																			Operation Not Recommended							120	113	107	102										
					CFM																																										340	309	276	234										
	345	225	CV EC	Minimum CFM	Power (W)																																										25	32	39	45	53	60	66	78	83					
					CFM																																										225	225	225	225	225	225	225	225	225					
				Default CFM	Power (W)																																										49	58	67	77	88	100	105	95	88					
					CFM																																										325	325	325	325	325	325	325	325	325					
Maximum CFM				Power (W)	126	134	131	125	119	118	105	98	90																																															
				CFM	375	375	375	375	375	375	375	375	375																																															

- Blower performance data is based on the lowest nameplate voltage setting.
- Blower performance is based on a wet coil with clean 1-inch filter.
- Blower performance is based on operating conditions of 80°F DB and 67°F WB.
- CFM Tolerance is ±7%.
- Cells in grey - option not available.
- The maximum allowable altitude of installation for this product is 6,561 ft (2,000 m).

Blower Performance SR*012

Models:
SR
006-060

Model	Rated CFM	Min CFM	Motor Type	Speed Tap	External Static Pressure (in. wg)																														
					0.1	0.2	0.3	0.4	0.5	0.6	0.7	0.8	0.9	1.0																					
SR012	400	300	PSC	Low	Power (W)	Operation Not Recommended																													
					CFM											360	350	320	310																
				Medium	Power (W)											Operation Not Recommended																			
					CFM																					420	400	380	360	340					
				High	Power (W)																					Operation Not Recommended									
					CFM																														
	400	300	CTEC	1	Power (W)	64	66	69	71	75	78	82	85	87	83																				
					CFM	358	345	332	319	305	291	275	261	247	218																				
				2	Power (W)	86	88	91	94	97	100	103	104	97	91																				
					CFM	400	388	377	365	354	342	328	309	269	237																				
				3	Power (W)	116	119	122	124	126	126	121	114	99	91																				
					CFM	449	437	427	414	401	385	359	327	274	238																				
				4	Power (W)	131	133	135	137	135	130	123	110	99	92																				
					CFM	467	456	444	433	414	390	361	318	273	239																				
	400	300	CV EC	Minimum CFM	Power (W)	55	64	73	81	90	99	107	106																						
					CFM	300	300	300	300	300	300	300	300																						
				Default CFM	Power (W)	105	115	125	135	132	127	123	118																						
					CFM	380	380	380	380	380	380	380	380																						
Maximum CFM				Power (W)	147	149	146	143	139	134	130	126	120																						
				CFM	415	415	415	415	415	415	415	415	415																						

- Blower performance data is based on the lowest nameplate voltage setting.
- Blower performance is based on a wet coil with clean 1-inch filter.
- Blower performance is based on operating conditions of 80°F DB and 67°F WB.
- CFM Tolerance is ±7%.
- Cells in grey - option not available.
- The maximum allowable altitude of installation for this product is 6,561 ft (2,000 m).

Blower Performance SR*015

Models:
SR
006-060

Model	Rated CFM	Min CFM	Motor Type	Speed Tap		External Static Pressure (in. wg)															
						0.1	0.2	0.3	0.4	0.5	0.6	0.7	0.8	0.9	1.0						
SR015	525	375	PSC	Low	Power (W)	161	158	146	138	Operation Not Recommended											
					CFM	503	490	479	439												
				Medium	Power (W)	184	181	174	153											143	
					CFM	595	575	562	510											451	
				High	Power (W)				174											159	141
					CFM				581											510	386
	525	375	CTEC	1	Power (W)	67	55	62	68	75	82										
					CFM	648	588	542	493	441	378										
				2	Power (W)	67	74	81	87	95	102						108				
					CFM	648	608	557	514	460	402						354				
				3	Power (W)	79	86	94	101	107	117						124	130			
					CFM	695	659	611	570	526	475						422	377			
				4	Power (W)	92	98	107	114	121	129						138	145	151		
					CFM	737	705	661	622	582	534						482	438	396		
				5	Power (W)	106	110	117	126	133	141						151	159	165	172	
					CFM	745	745	708	662	626	585						535	488	444	402	
	525	375	CV EC	Minimum CFM	Power (W)				84	99	114	129									
					CFM				375	375	375	375					375	375			
				Default CFM	Power (W)				55	74	90	108					127	147	166	186	
					CFM				525	525	525	525					525	525	525	525	
Maximum CFM				Power (W)	54	73	93	112	132	152	173	194					216	238			
				CFM	625	625	625	625	625	625	625	625					625	625			

- Blower performance data is based on the lowest nameplate voltage setting.
- Blower performance is based on a wet coil with clean 1-inch filter.
- Blower performance is based on operating conditions of 80°F DB and 67°F WB.
- CFM Tolerance is ±7%.
- Cells in grey - option not available.
- The maximum allowable altitude of installation for this product is 6,561 ft (2,000 m).

Blower Performance SR*018

Models:
SR
006-060

Model	Rated CFM	Min CFM	Motor Type	Speed Tap	External Static Pressure (in. wg)																
					0.1	0.2	0.3	0.4	0.5	0.6	0.7	0.8	0.9	1.0							
SR018	630	450	PSC	Low	Power (W)	147	145	135	127	Operation Not Recommended											
					CFM	524	509	493	451												
				Medium	Power (W)	170	167	161	143												
					CFM	611	588	564	514												
				High	Power (W)	195	189	184	177							149					
					CFM	704	668	643	617							504					
	630	450	CTEC	1	Power (W)	73	78	85	90												
					CFM	600	558	518	491												
				2	Power (W)	92	99	107	109							116	123	131			
					CFM	676	641	599	570							536	498	452			
				3	Power (W)	112	118	126	135							140	147	155	163	170	
					CFM	741	713	677	640							619	586	554	512	471	
				4	Power (W)	138	144	152	161							170	174	181	190	199	207
					CFM	802	780	751	714							680	662	633	603	567	529
				5	Power (W)	170	175	182	190							201	210	214	222	231	240
					CFM	854	848	820	791							754	724	711	683	655	625
	630	450	CV EC	Minimum CFM	Power (W)	Operation Not Recommended				93	111	132	157	180							
					CFM					450	450	450	450	450							
				Default CFM	Power (W)	85	101	113	145	178	206	228	248	266							
					CFM	600	600	600	600	600	600	600	600	600							
Maximum CFM				Power (W)	157	171	186	200	214	251	286	323									
				CFM	750	750	750	750	750	750	750	750	750								

- Blower performance data is based on the lowest nameplate voltage setting.
- Blower performance is based on a wet coil with clean 1-inch filter.
- Blower performance is based on operating conditions of 80°F DB and 67°F WB.
- CFM Tolerance is ±7%.
- Cells in grey - option not available.
- The maximum allowable altitude of installation for this product is 6,561 ft (2,000 m).

Blower Performance SR*024

Models:
SR
006-060

Model	Rated CFM	Min CFM	Motor Type	Speed Tap	External Static Pressure (in. wg)																	
					0.1	0.2	0.3	0.4	0.5	0.6	0.7	0.8	0.9	1.0								
SR024	800	600	PSC	Low	Power (W)	224	215	204	191	176	Operation Not Recommended											
					CFM	777	768	737	684	608												
				Medium	Power (W)	257	246	233	219	204						187						
					CFM	888	868	830	774	701						610						
				High	Power (W)	294	281	268	253	237						219						
					CFM	997	964	916	854	777						686						
	800	600	CTEC	1	Power (W)	116	122	128	135	Operation Not Recommended												
					CFM	755	728	695	653													
				2	Power (W)	146	152	159	166							174	185	193				
					CFM	836	810	782	750							708	657	616				
				3	Power (W)	181	187	194	201						209	218	230	239	246	252		
					CFM	910	887	861	834						804	762	714	674	642	619		
				4	Power (W)	232	240	247	254						262	270	278	291	303	312		
					CFM	996	975	952	929						904	876	845	798	755	725		
				5	Power (W)	Operation Not Recommended									323	331	340	348	361	374		
					CFM										999	975	951	923	884	840		
	800	600	CV EC	Minimum CFM	Power (W)	71	89	107	124	141	159	177	195	213	230							
					CFM	600	600	600	600	600	600	600	600	600	600							
				Default CFM	Power (W)	145	165	185	205	225	245	266	285	306	326							
					CFM	800	800	800	800	800	800	800	800	800	800							
Maximum CFM				Power (W)	284	300	315	332	351	364	379	396	412	428								
				CFM	1,000	1,000	1,000	1,000	1,000	1,000	1,000	1,000	1,000	1,000								

- Blower performance data is based on the lowest nameplate voltage setting.
- Blower performance is based on a wet coil with clean 1-inch filter.
- Blower performance is based on operating conditions of 80°F DB and 67°F WB.
- CFM Tolerance is ±7%.
- Cells in grey - option not available.
- The maximum allowable altitude of installation for this product is 6,561 ft (2,000 m).

Blower Performance SR*030

Models:
SR
006-060

Model	Rated CFM	Min CFM	Motor Type	Speed Tap		External Static Pressure (in. wg)																	
						0.1	0.2	0.3	0.4	0.5	0.6	0.7	0.8	0.9	1.0								
SR030	1,000	750	PSC	Low	Power (W)	305	290	274	256	236	Operation Not Recommended												
					CFM	916	911	883	833	761													
				Medium	Power (W)	338	323	306	288	268						246							
					CFM	1,021	1,014	983	929	850						747							
				High	Power (W)	384	372	357	340	322						301							
					CFM	1,084	1,076	1,044	988	906						800							
	1,000	750	CTEC	1	Power (W)	158	165	176	184	192	Operation Not Recommended												
					CFM	904	873	832	796	763													
				2	Power (W)	211	219	227	240	250						258	267	276	285				
					CFM	1,020	992	965	927	894						864	835	805	771				
				3	Power (W)	280	289	298	306	321						330	342	351	361	368			
					CFM	1,139	1,113	1,089	1,064	1,027						999	966	937	910	879			
				4	Power (W)	336	346	355	364	374						389	399	413	423	430			
					CFM	1,216	1,193	1,168	1,146	1,123						1,086	1,062	1,028	1,002	975			
				5	Power (W)				452	462						471	490	499	508	478			
					CFM				1,250	1,229						1,208	1,173	1,151	1,112	1,036			
				1,000	750	CV EC	Minimum CFM	Power (W)	71	89						108	127	145	162	181	199	217	235
								CFM	750	750						750	750	750	750	750	750	750	750
	Default CFM	Power (W)	251				274	296	315	337	362	387	407	Operation Not Recommended									
		CFM	1,000				1,000	1,000	1,000	1,000	1,000	1,000	1,000										
Maximum CFM	Power (W)	388	410				431	453	471	Operation Not Recommended													
	CFM	1,150	1,150				1,150	1,150	1,150														

- Blower performance data is based on the lowest nameplate voltage setting.
- Blower performance is based on a wet coil with clean 1-inch filter.
- Blower performance is based on operating conditions of 80°F DB and 67°F WB.
- CFM Tolerance is ±7%.
- Cells in grey - option not available.
- The maximum allowable altitude of installation for this product is 6,561 ft (2,000 m).

Blower Performance

SR*036

Models:
SR
006-060

Model	Rated CFM	Min CFM	Motor Type	Speed Tap	External Static Pressure (in. wg)																																															
					0.1	0.2	0.3	0.4	0.5	0.6	0.7	0.8	0.9	1.0																																						
SR036	1,150	900	PSC	Low	Power (W)	Operation Not Recommended																																														
					CFM											970	960	951	941	902																																
				Medium	Power (W)											Operation Not Recommended																																				
					CFM																					1,106	1,096	1,086	1,067	1,009	912																					
				High	Power (W)																					Operation Not Recommended																										
					CFM																															1,436	1,387	1,329	1,280	1,174	1,077	931										
	1,150	900	CTEC	1	Power (W)																															166	175	184	Operation Not Recommended													
					CFM																															974	941	904														
				2	Power (W)																															241	251	261								272	282	292	299	307		
					CFM																															1,132	1,103	1,074								1,041	1,005	973	944	916		
				3	Power (W)																															294	304	316								326	337	349	359	367	375	385
					CFM																															1,271	1,242	1,214								1,185	1,153	1,118	1,083	1,056	1,029	999
				4	Power (W)																															376	387	399								409	421	433	446	457	468	478
					CFM																															1,403	1,377	1,351								1,324	1,295	1,268	1,233	1,201	1,169	1,143
				5	Power (W)																															Option Not Available		499								510	523	524	521	519	516	514
					CFM																																	1,485								1,460	1,434	1,396	1,347	1,295	1,240	1,194
	1,150	900	CV EC	Minimum CFM	Power (W)																															105	132	164								188	211	233	257	280	307	339
					CFM																															900	900	900								900	900	900	900	900	900	900
Default CFM				Power (W)	205	232	261	303	349	382	415	446	475	505																																						
				CFM	1,150	1,150	1,150	1,150	1,150	1,150	1,150	1,150	1,150	1,150																																						
Maximum CFM				Power (W)	406	403	438	474	511	564	629	680	692	691																																						
				CFM	1,500	1,500	1,500	1,500	1,500	1,500	1,500	1,500	1,500	1,500																																						

- Blower performance data is based on the lowest nameplate voltage setting.
- Blower performance is based on a wet coil with clean 1-inch filter.
- Blower performance is based on operating conditions of 80°F DB and 67°F WB.
- CFM Tolerance is ±7%.
- Cells in grey - option not available.
- The maximum allowable altitude of installation for this product is 6,561 ft (2,000 m).

Blower Performance SR*042

Models:
SR
006-060

Model	Rated CFM	Min CFM	Motor Type	Speed Tap	External Static Pressure (in. wg)											
					0.1	0.2	0.3	0.4	0.5	0.6	0.7	0.8	0.9	1.0		
SR042	1,350	1,050	PSC	Low	Power (W)	388	Operation Not Recommended									
					CFM	918	Operation Not Recommended									
				Medium	Power (W)	517	509	496	477	452	422	Operation Not Recommended				
					CFM	1,201	1,223	1,218	1,185	1,125	1,038	Operation Not Recommended				
				High	Power (W)	665	654	636	611	580	542	498	Operation Not Recommended			
					CFM	1,584	1,592	1,571	1,518	1,436	1,323	1,180	Operation Not Recommended			
	1,350	1,050	CTEC	1	Power (W)	238	248	259	272	Operation Not Recommended						
					CFM	1,186	1,152	1,113	1,056	Operation Not Recommended						
				2	Power (W)	331	369	352	365	381	396	411	423	437	446	
					CFM	1,345	1,317	1,283	1,251	1,215	1,181	1,150	1,124	1,094	1,050	
				3	Power (W)	448	461	474	486	501	518	534	551	568	581	
					CFM	1,507	1,482	1,455	1,427	1,396	1,365	1,331	1,296	1,276	1,246	
				4	Power (W)	582	595	609	622	635	651	669	688	706	681	
					CFM	1,641	1,623	1,601	1,577	1,548	1,519	1,488	1,455	1,423	1,355	
				5	Power (W)	Operation Not Recommended		756	775	776	774	772	768	765	679	
					CFM	Operation Not Recommended		1,743	1,717	1,688	1,645	1,596	1,541	1,490	1,352	
	1,350	1,050	CV EC	Minimum CFM	Power (W)	154	177	200	224	252	280	306	331	355	383	
					CFM	1,050	1,050	1,050	1,050	1,050	1,050	1,050	1,050	1,050	1,050	
				Default CFM	Power (W)	334	359	390	421	453	484	517	555	595	636	
					CFM	1,400	1,400	1,400	1,400	1,400	1,400	1,400	1,400	1,400	1,400	
Maximum CFM				Power (W)	658	674	703	700	697	Operation Not Recommended						
				CFM	1,750	1,750	1,750	1,750	1,750	Operation Not Recommended						

- Blower performance data is based on the lowest nameplate voltage setting.
- Blower performance is based on a wet coil with clean 1-inch filter.
- Blower performance is based on operating conditions of 80°F DB and 67°F WB.
- CFM Tolerance is ±7%.
- Cells in grey - option not available.
- The maximum allowable altitude of installation for this product is 6,561 ft (2,000 m).

Blower Performance SR*048

Models:
SR
006-060

Model	Rated CFM	Min CFM	Motor Type	Speed Tap		External Static Pressure (in. wg)														
						0.1	0.2	0.3	0.4	0.5	0.6	0.7	0.8	0.9	1.0					
SR048	1,550	1,200	PSC	Low	Power (W)	608	585	559	531	499	Operation Not Recommended									
					CFM	1,512	1,487	1,440	1,371	1,280										
				Medium	Power (W)	680	652	622	588	552						513				
					CFM	1,670	1,639	1,584	1,507	1,406						1,281				
				High	Power (W)	780	746	709	669	625						579	529			
					CFM	1,885	1,841	1,772	1,678	1,560						1,416	1,248			
	1,550	1,200	CT EC	1	Power (W)	286	303	320	336	351										
					CFM	1,482	1,411	1,342	1,276	1,211										
				2	Power (W)	360	379	397	415	433						450	467			
					CFM	1,604	1,553	1,500	1,444	1,385						1,323	1,258			
				3	Power (W)	457	472	488	505	525						546	569			
					CFM	1,753	1,707	1,659	1,607	1,553						1,495	1,435			
				4	Power (W)	626	642	658	673	687						701				
					CFM	1,984	1,937	1,890	1,843	1,795						1,747				
				5	Power (W)				805	829										
					CFM				1,980	1,938										
	1,550	1,200	CV EC	Minimum CFM	Power (W)	240	132	163	293	342						309	280	395	401	453
					CFM	1,200	1,200	1,200	1,200	1,200						1,200	1,200	1,200	1,200	1,200
				Default CFM	Power (W)	445	251	294	500	570						498	438	617	602	672
					CFM	1,550	1,550	1,550	1,550	1,550						1,550	1,550	1,550	1,550	1,550
Maximum CFM				Power (W)	723	418	474	780	873	761	644	912	853	939						
				CFM	1,900	1,900	1,900	1,900	1,900	1,900	1,900	1,900	1,900	1,900						

- Blower performance data is based on the lowest nameplate voltage setting.
- Blower performance is based on a wet coil with clean 1-inch filter.
- Blower performance is based on operating conditions of 80°F DB and 67°F WB.
- CFM Tolerance is ±7%.
- Cells in grey - option not available.
- The maximum allowable altitude of installation for this product is 6,561 ft (2,000 m).

Blower Performance SR*060

Models:
SR
006-060

Model	Rated CFM	Min CFM	Motor Type	Speed Tap		External Static Pressure (in. wg)																				
						0.1	0.2	0.3	0.4	0.5	0.6	0.7	0.8	0.9	1.0											
SR060	2,000	1,500	PSC	Low	Power (W)	779	766	750	731	710	686	659	Operation Not Recommended													
					CFM	1,771	1,756	1,732	1,700	1,658	1,608	1,549														
				Medium	Power (W)	877	856	833	806	777	744	708					669									
					CFM	1,979	1,968	1,940	1,894	1,831	1,751	1,653					1,539									
				High	Power (W)	996	969	938	904	867	826	783					736	687								
					CFM	2,208	2,178	2,132	2,069	1,990	1,893	1,780					1,649	1,502								
	2,000	1,500	CTEC	1	Power (W)	342	354	366	380	Operation Not Recommended																
					CFM	1,685	1,640	1,593	1,545																	
				2	Power (W)	460	476	489	501								518	533	548	561	577					
					CFM	1,879	1,833	1,795	1,754								1,705	1,657	1,608	1,563	1,514					
				3	Power (W)	648	666	678	694								708	724	740	757	773					
					CFM	2,113	2,069	2,039	1,998								1,963	1,925	1,885	1,840	1,795					
				4	Power (W)	771	785	803	817								832	848	864	883	900					
					CFM	2,235	2,198	2,163	2,130								2,094	2,061	2,019	1,977	1,939					
				5	Power (W)	866	881	899	916								934	951	970	977	973	969				
					CFM	2,322	2,290	2,253	2,219								2,188	2,152	2,120	2,083	2,013	1,940				
				2,000	1,500	CV EC	Minimum CFM	Power (W)	246								301	354	405	453	500	544	587	627	665	
								CFM	1,500								1,500	1,500	1,500	1,500	1,500	1,500	1,500	1,500	1,500	
Default CFM	Power (W)	503	564				631	686	734					808	875	929	990	1,051								
	CFM	2,000	2,000				2,000	2,000	2,000					2,000	2,000	2,000	2,000	2,000								
Maximum CFM	Power (W)	885	896				901	916	937					Operation Not Recommended												
	CFM	2,200	2,200				2,200	2,200	2,200																	

- Blower performance data is based on the lowest nameplate voltage setting.
- Blower performance is based on a wet coil with clean 1-inch filter.
- Blower performance is based on operating conditions of 80°F DB and 67°F WB.
- CFM Tolerance is ±7%.
- Cells in grey - option not available.
- The maximum allowable altitude of installation for this product is 6,561 ft (2,000 m).

Blower Performance Hybrid Unit SR*024

Models:
SR
006-060

Model	Rated CFM	Min CFM	Motor Type	Speed Tap	External Static Pressure (in. wg)											
					0.1	0.2	0.3	0.4	0.5	0.6	0.7	0.8	0.9	1.0		
SR024	800	600	CT EC	1	RPM	816	871	928	988	1,045	1,119	Operation Not Recommended				
					Power (W)	125	133	141	149	157	168					
					CFM	787	756	723	686	649	604					
				2	RPM	875	925	974	1,030	1,084	1,137	1,196	1,271	1,315	Operation Not Recommended	
					Power (W)	160	168	177	186	195	204	214	227	235		
					CFM	876	848	819	787	753	720	684	634	603		
				3	RPM	934	979	1,026	1,070	1,124	1,174	1,224	1,275	1,339	1,399	
					Power (W)	200	209	218	226	237	247	257	267	280	293	
					CFM	962	936	909	883	851	820	789	755	715	676	
				4	RPM	Operation Not Recommended			1,083	1,127	1,167	1,218	1,263	1,309	1,355	1,405
					Power (W)	Operation Not Recommended			270	280	289	301	311	322	333	345
					CFM	Operation Not Recommended			1,004	980	954	925	896	867	838	807
	5	RPM	Operation Not Recommended						1,314	1,357	1,399	1,444				
		Power (W)	Operation Not Recommended						380	391	403	416				
		CFM	Operation Not Recommended						1,004	977	950	923				
	800	600	CV EC	Minimum CFM	RPM	766	833	899	967	1,037	1,101	1,167	1,235	1,302	1,369	
					Power (W)	80	99	118	136	154	174	193	211	229	248	
					CFM	600	600	600	600	600	600	600	600	600	600	
				Default CFM	RPM	890	950	1,006	1,071	1,141	1,192	1,247	1,312	1,372	1,433	
					Power (W)	148	172	194	218	244	265	287	312	335	359	
					CFM	800	800	800	800	800	800	800	800	800	800	
Maximum CFM				RPM	1,034	1,088	1,144	1,195	1,244	1,302	1,358	1,409	1,463	1,516		
				Power (W)	256	285	316	343	368	401	432	459	488	517		
				CFM	1,000	1,000	1,000	1,000	1,000	1,000	1,000	1,000	1,000	1,000		

- Blower performance data is based on the lowest nameplate voltage setting.
- Blower performance is based on a wet coil with clean 1-inch filter.
- Blower performance is based on operating conditions of 80°F DB and 67°F WB.
- CFM Tolerance is ±7%.
- Cells in grey - option not available.
- The maximum allowable altitude of installation for this product is 6,561 ft (2,000 m).

Blower Performance Hybrid Unit SR*030

Models:
SR
006-060

Model	Rated CFM	Min CFM	Motor Type	Speed Tap	External Static Pressure (in. wg)												
					0.1	0.2	0.3	0.4	0.5	0.6	0.7	0.8	0.9	1.0			
SR030	1,000	750	CT EC	1	RPM	886	927	965	994	1,040	1,071	1,101					
					Power (W)	205	214	222	229	239	246	252					
					CFM	916	886	857	837	799	772	749					
				2	RPM	969	1,009	1,045	1,077	1,109	1,139	1,168	1,214	1,234	1,267		
					Power (W)	277	287	297	306	314	322	330	342	348	357		
					CFM	1,030	1,004	977	951	929	907	883	838	828	807		
				3	RPM	1,058	1,097	1,131	1,162	1,192	1,221	1,249	1,281	1,322	1,330		
					Power (W)	369	382	393	404	414	423	432	443	456	460		
					CFM	1,147	1,123	1,098	1,075	1,052	1,030	1,012	986	947	949		
				4	RPM				1,180	1,213	1,243	1,272	1,300	1,326	1,352	1,377	1,400
					Power (W)				494	507	518	530	541	551	561	571	580
					CFM				1,244	1,219	1,198	1,176	1,152	1,134	1,116	1,098	1,082
	5	RPM								1,434	1,458	1,477					
		Power (W)	Operation Not Recommended							711	722	723					
		CFM								1,246	1,228	1,200					
	1,000	750	CV EC	Minimum CFM	RPM	841	892	942	994	1,048	1,096	1,146	1,198	1,249	1,300		
					Power (W)	160	184	208	232	256	280	304	328	352	375		
					CFM	750	750	750	750	750	750	750	750	750	750		
				Default CFM	RPM	1,027	1,070	1,112	1,156	1,202	1,243	1,285	1,330	1,373	1,416		
					Power (W)	324	354	383	413	443	472	502	532	561	591		
					CFM	1,000	1,000	1,000	1,000	1,000	1,000	1,000	1,000	1,000	1,000		
Maximum CFM				RPM	1,211	1,245	1,271	1,312	1,361	1,379	1,405						
				Power (W)	604	626	635	671	720	716	725						
				CFM	1,250	1,250	1,250	1,250	1,250	1,250	1,250						

- Blower performance data is based on the lowest nameplate voltage setting.
- Blower performance is based on a wet coil with clean 1-inch filter.
- Blower performance is based on operating conditions of 80°F DB and 67°F WB.
- CFM Tolerance is ±7%.
- Cells in grey - option not available.
- The maximum allowable altitude of installation for this product is 6,561 ft (2,000 m).

Blower Performance Hybrid Unit

SR*036

Models:
SR
006-060

Model	Rated CFM	Min CFM	Motor Type	Speed Tap	External Static Pressure (in. wg)											
					0.1	0.2	0.3	0.4	0.5	0.6	0.7	0.8	0.9	1.0		
SR036	1,150	900	CT EC	1	RPM	791	831	872	912	954	Operation Not Recommended					
					Power (W)	180	189	198	206	215						
					CFM	1,032	1,003	970	938	903						
				2	RPM	838	875	912	950	990	1,033	1,071				
					Power (W)	218	227	236	246	255	265	275				
					CFM	1,116	1,089	1,062	1,031	997	963	930				
				3	RPM	902	937	971	1,006	1,041	1,076	1,111	1,150	1,193	1,249	
					Power (W)	280	290	300	310	320	330	340	351	364	380	
					CFM	1,229	1,206	1,180	1,153	1,125	1,095	1,068	1,036	1,001	944	
				4	RPM	993	1,026	1,057	1,088	1,119	1,152	1,184	1,214	1,247	1,283	
					Power (W)	391	402	414	425	436	448	459	470	482	496	
					CFM	1,398	1,374	1,354	1,329	1,304	1,278	1,252	1,226	1,201	1,172	
	5	RPM	1,046	1,079	1,107	1,139	1,170	1,186	1,226	1,258	1,287	1,318				
		Power (W)	474	487	498	511	530	527	544	557	570	584				
		CFM	1,503	1,480	1,458	1,438	1,428	1,388	1,361	1,338	1,313	1,290				
	1,150	900	CV EC	Minimum CFM	RPM	728	784	838	895	953	1,006	1,060	1,117			
					Power (W)	126	148	171	193	215	238	261	284			
					CFM	900	900	900	900	900	900	900	900			
				Default CFM	RPM	883	931	976	1,026	1,077	1,120	1,166	1,215	1,263	1,310	
					Power (W)	253	283	311	341	372	400	429	459	489	518	
					CFM	1,150	1,150	1,150	1,150	1,150	1,150	1,150	1,150	1,150	1,150	
				Maximum CFM	RPM	1,023	1,065	1,107	1,150	1,194	Operation Not Recommended					
					Power (W)	446	485	524	563	601						
					CFM	1,500	1,500	1,500	1,500	1,500						

- Blower performance data is based on the lowest nameplate voltage setting.
- Blower performance is based on a wet coil with clean 1-inch filter.
- Blower performance is based on operating conditions of 80°F DB and 67°F WB.
- CFM Tolerance is ±7%.
- Cells in grey - option not available.
- The maximum allowable altitude of installation for this product is 6,561 ft (2,000 m).

Blower Performance Hybrid Unit SR*042

Models:
SR
006-060

Model	Rated CFM	Min CFM	Motor Type	Speed Tap	External Static Pressure (in. wg)												
					0.1	0.2	0.3	0.4	0.5	0.6	0.7	0.8	0.9	1.0			
SR042	1,400	1,050	CT EC	1	RPM	883	918	954	992	1,030	Operation Not Recommended						
					Power (W)	248	257	266	277	287							
					CFM	1,189	1,156	1,126	1,089	1,053							
				2	RPM	970	1,001	1,033	1,065	1,097	1,130	1,168	1,207	1,245	Operation Not Recommended		
					Power (W)	338	349	359	370	380	391	403	417	429			
					CFM	1,348	1,320	1,290	1,259	1,227	1,195	1,163	1,124	1,087			
				3	RPM	1,068	1,098	1,126	1,153	1,182	1,211	1,240	1,271	1,302	1,340	Operation Not Recommended	
					Power (W)	465	479	490	502	513	525	537	550	562	578		
					CFM	1,513	1,485	1,460	1,432	1,405	1,375	1,349	1,319	1,287	1,254		
				4	RPM	1,160	1,185	1,213	1,237	1,262	1,289	1,314	1,340	1,367	1,395	Operation Not Recommended	
					Power (W)	611	625	638	649	661	675	688	700	714	728		
					CFM	1,679	1,655	1,628	1,604	1,577	1,553	1,529	1,503	1,476	1,450		
				5	RPM	Operation Not Recommended		1,271	1,292	1,309	1,327	1,346	1,364	1,385	1,405	Operation Not Recommended	
					Power (W)			753	761	759	757	756	754	753	751		
					CFM			1,736	1,709	1,672	1,634	1,595	1,558	1,514	1,472		
	1,400	1,050	CV EC	Minimum CFM	RPM	816	870	921	976	1,034	Operation Not Recommended						
					Power (W)	176	204	232	260	288							
					CFM	1,050	1,050	1,050	1,050	1,050							
				Default CFM	RPM	986	1,032	1,077	1,125	1,173	1,217	1,262	1,309	1,356	1,402	Operation Not Recommended	
					Power (W)	360	397	434	471	508	545	582	619	656	693		
					CFM	1,400	1,400	1,400	1,400	1,400	1,400	1,400	1,400	1,400	1,400		
Maximum CFM				RPM	Operation Not Recommended		1,265	1,284	Operation Not Recommended								
				Power (W)			778	776									
				CFM			1,750	1,750									

- Blower performance data is based on the lowest nameplate voltage setting.
- Blower performance is based on a wet coil with clean 1-inch filter.
- Blower performance is based on operating conditions of 80°F DB and 67°F WB.
- CFM Tolerance is ±7%.
- Cells in grey - option not available.
- The maximum allowable altitude of installation for this product is 6,561 ft (2,000 m).

Blower Performance Hybrid Unit SR*048

Models:
SR
006-060

Model	Rated CFM	Min CFM	Motor Type	Speed Tap	External Static Pressure (in. wg)										
					0.1	0.2	0.3	0.4	0.5	0.6	0.7	0.8	0.9	1.0	
SR048	1,500	1,200	CT EC	1	RPM	731	770	807	840	Operation Not Recommended					
					Power (W)	251	263	275	285						
					CFM	1,396	1,328	1,262	1,206						
				2	RPM	798	833	867	900	931	963	1,000	Operation Not Recommended		
					Power (W)	340	354	366	378	389	401	415			
					CFM	1,576	1,517	1,449	1,393	1,343	1,291	1,235			
				3	RPM	864	902	935	965	995	1,024	1,054	1,085	1,121	1,183
					Power (W)	458	476	491	505	519	533	547	561	578	608
					CFM	1,767	1,715	1,655	1,599	1,546	1,497	1,449	1,400	1,345	1,259
				4	RPM	927	956	986	1,016	1,044	1,084	1,112	1,138	1,166	1,194
					Power (W)	598	615	632	649	666	682	698	713	729	747
					CFM	1,980	1,928	1,877	1,824	1,772	1,697	1,651	1,609	1,565	1,521
	5	RPM	Operation Not Recommended				1,103	1,129	1,155	1,181	1,207	1,232			
		Power (W)	Operation Not Recommended				831	848	866	885	904	921			
		CFM	Operation Not Recommended				1,963	1,916	1,872	1,830	1,791	1,755			
	1,500	1,200	CV EC	Minimum CFM	RPM	724	774	824	875	928	977	1,026	1,078	1,129	1,179
					Power (W)	192	231	272	310	348	389	429	468	508	547
					CFM	1,200	1,200	1,200	1,200	1,200	1,200	1,200	1,200	1,200	1,200
				Default CFM	RPM	883	925	965	1,008	1,052	1,091	1,131	1,174	1,216	1,257
					Power (W)	408	453	498	544	589	634	679	725	770	815
					CFM	1,500	1,500	1,500	1,500	1,500	1,500	1,500	1,500	1,500	1,500
Maximum CFM				RPM	993	1,031	1,068	1,109	1,151	1,187	1,224	1,264	1,303	1,342	
				Power (W)	625	678	730	786	843	893	945	1,000	1,054	1,108	
				CFM	1,900	1,900	1,900	1,900	1,900	1,900	1,900	1,900	1,900	1,900	

- Blower performance data is based on the lowest nameplate voltage setting.
- Blower performance is based on a wet coil with clean 1-inch filter.
- Blower performance is based on operating conditions of 80°F DB and 67°F WB.
- CFM Tolerance is ±7%.
- Cells in grey - option not available.
- The maximum allowable altitude of installation for this product is 6,561 ft (2,000 m).

Blower Performance Hybrid Unit SR*060

Models:
SR
006-060

Model	Rated CFM	Min CFM	Motor Type	Speed Tap	External Static Pressure (in. wg)											
					0.1	0.2	0.3	0.4	0.5	0.6	0.7	0.8	0.9	1.0		
SR060	1,950	1,500	CT EC	1	RPM	856	886	916	946	978	Operation Not Recommended					
					Power (W)	448	462	476	490	505						
					CFM	1,739	1,693	1,646	1,595	1,546						
				2	RPM	943	969	997	1,026	1,054	1,081	1,110	1,140	1,170	1,199	
					Power (W)	622	637	654	670	687	702	719	736	753	770	
					CFM	1,954	1,915	1,872	1,828	1,780	1,736	1,692	1,648	1,604	1,562	
				3	RPM	1,029	1,053	1,079	1,106	1,133	1,159	1,185	1,210	1,230	1,250	
					Power (W)	833	850	868	887	906	925	943	960	957	953	
					CFM	2,166	2,126	2,087	2,045	2,000	1,954	1,914	1,872	1,814	1,755	
				4	RPM	1,049	1,073	1,099	1,125	1,149	1,169	1,189	1,208	1,228	1,248	
					Power (W)	897	915	934	952	963	959	955	952	948	946	
					CFM	2,224	2,186	2,145	2,107	2,055	1,988	1,926	1,864	1,804	1,745	
	5	RPM	Operation Not Recommended													
		Power (W)														
		CFM														
	1,950	1,500	CV EC	Minimum CFM	RPM	814	862	908	956	1,006	1,051	1,097	1,145	1,192	1,240	
					Power (W)	324	376	428	479	530	582	634	685	736	788	
					CFM	1,500	1,500	1,500	1,500	1,500	1,500	1,500	1,500	1,500	1,500	
Default CFM				RPM	1,046	1,072	1,093	1,123	1,158	1,175	1,196	Operation Not Recommended				
				Power (W)	854	872	874	908	956	943	945					
				CFM	1,950	1,950	1,950	1,950	1,950	1,950	1,950					
Maximum CFM				RPM	1,078	1,097	1,116	Operation Not Recommended								
				Power (W)	955	950	946									
				CFM	2,200	2,200	2,200									

- Blower performance data is based on the lowest nameplate voltage setting.
- Blower performance is based on a wet coil with clean 1-inch filter.
- Blower performance is based on operating conditions of 80°F DB and 67°F WB.
- CFM Tolerance is ±7%.
- Cells in grey - option not available.
- The maximum allowable altitude of installation for this product is 6,561 ft (2,000 m).

Waterside Economizers Performance

Models:
SR
006-060

1,200 CFM Rated Airflow - SR036

EWT °F	FLOW GPM/Ton	SR036				
		Waterside		Capacity		
		PD psi	PD ft	TC	SC	LWT
45	1.50	0.3	0.7	18.768	17.626	53.3
45	2.25	0.9	2.1	22.404	20.058	51.6
45	3.00	1.7	4.0	25.142	21.717	50.6
50	1.50	0.3	0.6	16.318	15.344	57.3
50	2.25	0.9	2.0	19.284	17.552	55.7
50	3.00	1.7	4.0	21.383	19.009	54.8
55	1.50	0.3	0.6	13.912	12.951	61.2
55	2.25	0.9	2.1	16.212	14.929	59.8
55	3.00	1.8	4.1	17.675	16.181	58.9
60	1.50	0.3	0.8	11.549	10.445	65.1
60	2.25	0.9	2.3	13.190	12.188	63.9
60	3.00	1.9	4.5	14.020	13.232	63.1

- Interpolation is permissible, extrapolation is not.
- All entering air conditions are 80°F (26.6°C) DB and 67°F (19.4°C) WB.
- See performance correction tables for operating conditions other than those listed above.

1,600 CFM Rated Airflow - SR048

EWT °F	FLOW GPM/Ton	SR048				
		Waterside		Capacity		
		PD psi	PD ft	TC	SC	LWT
45	1.50	0.9	2.2	29.364	26.323	54.8
45	2.25	1.5	3.4	34.188	29.606	52.6
45	3.00	2.1	4.9	37.671	31.675	51.3
50	1.50	1.0	2.2	25.063	22.810	58.4
50	2.25	1.5	3.4	28.940	25.807	56.4
50	3.00	2.2	5.0	31.653	27.659	55.3
55	1.50	1.0	2.2	21.061	19.070	62.0
55	2.25	1.5	3.4	24.060	21.779	60.3
55	3.00	2.2	5.0	26.048	23.413	59.3
60	1.50	0.9	2.2	17.384	15.081	65.8
60	2.25	1.5	3.4	19.572	17.506	64.3
60	3.00	2.2	5.0	20.879	18.924	63.5

- Interpolation is permissible, extrapolation is not.
- All entering air conditions are 80°F (26.6°C) DB and 67°F (19.4°C) WB.
- See performance correction tables for operating conditions other than those listed above.

1,400 CFM Rated Airflow - SR042

EWT °F	FLOW GPM/Ton	SR042				
		Waterside		Capacity		
		PD psi	PD ft	TC	SC	LWT
45	1.50	0.5	1.1	21.057	20.113	53.0
45	2.25	1.3	3.0	25.064	22.800	51.4
45	3.00	2.4	5.6	27.879	24.488	50.3
50	1.50	0.4	1.0	18.254	17.544	57.0
50	2.25	1.3	2.9	21.453	19.959	55.4
50	3.00	2.4	5.6	23.492	21.398	54.5
55	1.50	0.5	1.1	15.497	14.853	60.9
55	2.25	1.3	3.0	17.895	16.990	59.5
55	3.00	2.5	5.8	19.160	18.176	58.6
60	1.50	0.6	1.3	12.787	12.039	64.9
60	2.25	1.4	3.3	14.389	13.893	63.7
60	3.00	2.7	6.2	14.884	14.823	62.8

- Interpolation is permissible, extrapolation is not.
- All entering air conditions are 80°F (26.6°C) DB and 67°F (19.4°C) WB.
- See performance correction tables for operating conditions other than those listed above.

2,000 CFM Rated Airflow - SR060

EWT °F	FLOW GPM/Ton	SR060				
		Waterside		Capacity		
		PD psi	PD ft	TC	SC	LWT
45	1.50	1.2	2.7	33.525	32.134	53.9
45	2.25	1.9	4.5	38.794	35.768	51.9
45	3.00	3.0	6.9	42.388	37.813	50.7
50	1.50	1.2	2.8	28.521	27.934	57.6
50	2.25	1.9	4.6	32.687	31.220	55.8
50	3.00	3.0	6.9	35.360	32.993	54.7
55	1.50	1.2	2.8	23.862	23.471	61.4
55	2.25	1.9	4.6	26.996	26.408	59.8
55	3.00	3.0	7.0	28.793	27.909	58.8
60	1.50	1.2	2.7	19.574	18.723	65.2
60	2.25	1.9	4.6	21.744	21.316	63.9
60	3.00	3.0	7.0	22.709	22.548	63.0

- Interpolation is permissible, extrapolation is not.
- All entering air conditions are 80°F (26.6°C) DB and 67°F (19.4°C) WB.
- See performance correction tables for operating conditions other than those listed above.

PD Table for WSE Three-Way Valve

Unit Size	Econ - ON	Econ - OFF
	C _v	
036	11.7	5.8
042	11.7	5.8
048	18.7	9.3
060	18.7	9.3

ClimateMaster works continually to improve its products. As a result, the design and specifications of each product at the time of order may be changed without notice and may not be as described herein. Please contact ClimateMaster's Customer Service Department at 800-299-9747 for specific information on the current design and specifications. Statements and other information contained herein are not express warranties and do not form the basis of any bargain between the parties, but are merely ClimateMaster's opinion or commendation of its products. The latest version of this document is available at www.climatemaster.com. Engineered and assembled in the USA. © ClimateMaster, Inc. All Rights Reserved 2024

Tranquility (SR) Series

Unit Size	006	009	012	015	018	024	030	036	042	048	060
Number of refrigerant circuits	1	1	1	1	1	1	1	1	1	1	1
Factory Charge R-454B - (oz.)	17	18	21	29	37	40	39	46	56	56	69
Refrigerant Leak Detection System	O	O	O	O	O	O	O	O	O	O	R
Number of Sensors	2	2	2	2	2	2	2	2	2	2	2
Water Connection Size											
Source FPT	1/2"	1/2"	1/2"	1/2"	1/2"	3/4"	3/4"	3/4"	3/4"	1"	1"
System Water Volume (gallons)	0.143	0.143	0.167	0.286	0.45	0.323	0.323	0.738	0.89	0.89	0.939
Vertical											
Filter Standard - 1" Throwaway	10X18	10X18	10X18	20X20	20X20	20x20	20x20	24x24	24x24	28x28	28x28
Weight - Operating (lbs.)	110	112	121	163	168	216	224	245	260	315	330
Weight - Packaged (lbs.)	115	117	126	168	173	221	229	251	266	322	337
Horizontal											
Filter Standard - 1" Throwaway	10X18	10X18	10X18	16X25	16X25	18x24	18x24	2-14x20	2-14x20	1-20x24 1-14x20	1-20x24 1-14x20
Weight - Operating (lbs.)	110	112	121	163	168	208	208	233	244	299	314
Weight - Packaged (lbs.)	115	117	126	168	173	213	213	239	250	306	321
Vertical - Hot Water Generator											
FPT - All Other				1/2"	1/2"	1/2"	1/2"	1/2"	1/2"	1/2"	1/2"
Weight - Operating (lbs.)				178	183	231	239	260	275	330	345
Weight - Packaged (lbs.)				183	188	236	244	266	281	337	352
Horizontal - Hot Water Generator											
FPT - All Other				1/2"	1/2"	1/2"	1/2"	1/2"	1/2"	1/2"	1/2"
Weight - Operating (lbs.)				178	183	223	223	248	259	314	329
Weight - Packaged (lbs.)				183	188	228	228	254	265	321	336

Notes:

All dimensions displayed above are in inches unless otherwise marked.

All units have TXV and 1/2-inch and 3/4-inch electrical knockouts.

The standard Condensate Drain Connection is a rubber coupling that couples to 3/4-inch schedule 40/80 PVC.

The optional Stainless Steel Condensate Drain Connection is 3/4-inch FPT.

575V fan motors are two speed.

FPT=Female Pipe Thread

O = Optional, R = Required

Tranquility (SR) Hybrid Series

Unit Size	024	030	036	042	048	060
Number of refrigerant circuits	1	1	1	1	1	1
Factory Charge R-454B - (oz.)	40	39	46	56	56	69
Refrigerant Leak Detection System	O	O	O	O	O	R
Number of Sensors	2	2	2	2	2	2
Water Connection Size						
Source FPT	3/4"	3/4"	3/4"	3/4"	1"	1"
System Water Volume (gallons)	0.323	0.323	0.738	0.89	0.89	0.939
Horizontal						
Filter Standard - 1" Throwaway	18x24	18x24	2-14x20	2-14x20	1-20x24 1-14x20	1-20x24 1-14x20
Weight - Operating (lbs.)	253	261	309	324	373	405
Weight - Packaged (lbs.)	258	266	314	329	378	410

Tranquility (SR) with WSE Option

Unit Size	036	042	048	060
Water Connection Size				
Source FPT	3/4"	3/4"	1"	1"
System Water Volume (gallons)	0.738	0.89	0.89	0.939
Vertical				
Weight - Operating (lbs.)	289	303	353	368
Weight - Packaged (lbs.)	295	310	360	375
Water Volume (gal)	0.746	0.746	1.001	1.001
Horizontal				
Weight - Operating (lbs.)	311	326	372	387
Weight - Packaged (lbs.)	317	332	379	394
Water Volume (gal)	0.735	0.735	1.041	1.041

Tranquility (SR) with Hot Gas Reheat Option

Unit Size	018	024	030	036	042	048	060
Number of refrigerant circuits	1	1	1	1	1	1	1
Factory Charge R-454B - (oz.)	37	40	39	46	56	56	69
Refrigerant Leak Detection System	O	O	O	O	O	O	R
Number of Sensors	2	2	2	2	2	2	2
Water Connection Size							
Source FPT	1/2"	3/4"	3/4"	3/4"	3/4"	1"	1"
System Water Volume (gallons)	0.45	0.323	0.323	0.738	0.89	0.89	0.939
Horizontal							
Filter Standard - 1" Throwaway	16X25	18x24	18x24	2-14x20	2-14x20	1-20x24 1-14x20	1-20x24 1-14x20
Weight - Operating (lbs.)	253	253	261	309	324	373	405
Weight - Packaged (lbs.)	258	258	266	314	329	378	410

Unit Maximum Water Working Pressure

Options	Max Pressure PSIG [kPa]
Base Unit	300 [2,068]
Internal Secondary Pump (ISP)	145 [999]
Internal Motorized Water Valve (MWV)	300 [2,068]
Internal Auto Flow Valve	300 [2,068]

Use the lowest maximum pressure rating when multiple options are combined.

Standard Dimensional Data

Models:
SR
006-060

Cabinet Dimensions (inches)

Model	Cabinet Config	Depth/Length	Width	Height
		A	B	C
SR006-012	H	40.3	22.5	11.1
	V	21.3	22.5	22.0
SR015-018	H	48.4	22.5	17.0
	V	22.5	22.5	40.0
SR024-030	H	48.4	22.5	18.3
	V	22.5	22.5	40.0
SR036-042	H	53.3	22.5	21.0
	V	26.0	22.5	45.0
SR048-060	H	68.0	25.5	21.0
	V	29.3	25.5	50.5

Electrical Knockouts (inches)

Model	Cabinet Config	H	Low Voltage	High Voltage	G	Electric Heater KO	
			J	K		X	Y
			KO 1/2"	KO 3/4"			
SR006-012	H	3.6	5.9	8.9	1.1		
	V	3.6	5.9	8.1	1.1		
SR015-018	H	4.1	7.1	14.8	1.3	1.5	3.9
	V	4.1	7.1	14.8	1.3	1.7	2.7
SR024-030	H	4.1	7.1	14.8	1.3	1.5	5.1
	V	4.1	6.7	14.8	1.3	1.7	2.7
SR036-042	H	4.1	7.1	15.8	1.3	1.1	6.3
	V	4.1	7.1	15.8	1.3	1.7	2.7
SR048-060	H	4.1	7.1	16.7	1.3	1.5	6.3
	V	4.1	7.1	16.7	1.3	2.3	3.3

Shipping and Water Connections (inches)

Model	Cabinet Config	Shipping Overall Dimensions			Water Connections								Condensate Drain Pan			
		Depth/Length	Width	Height	Water In		Water Out		Water In/Out	HWG In		HWG Out		AA	BB	Condensate Drain Pan Fitting
					D	E	F	E		DD	EE	FF	EE			
SR006-012	H	46.0	28.4	17.0	3.7	1.5	8.6	1.5	1/2"					3.3	0.6	*3/4" MPT
	V	27.0	28.0	28.0	3.7	1.5	8.6	1.5	1/2"					1.5	11.7	*3/4" MPT
SR015-018	H	53.5	28.4	23.0	3.7	2.0	9.8	2.0	1/2"	12.6	1.6	14.9	1.6	3.3	0.9	*3/4" MPT
	V	27.3	27.3	46.0	3.7	2.0	9.8	2.0	1/2"	12.6	1.6	14.9	1.6	1.5	19.7	*3/4" MPT
SR024-030	H	53.5	28.4	24.3	3.7	2.0	9.8	2.0	3/4"	13.1	1.6	15.8	1.6	3.4	0.8	*3/4" MPT
	V	27.3	27.3	46.0	3.7	2.0	9.8	2.0	3/4"	13.1	1.6	15.8	1.6	1.4	19.7	*3/4" MPT
SR036-042	H	58.5	28.4	27.0	3.7	2.0	11.1	2.0	3/4"	14.8	1.6	17.6	1.6	3.4	0.8	*3/4" MPT
	V	31.0	28.0	51.0	3.7	2.0	11.1	2.0	3/4"	14.8	1.6	17.6	1.6	1.4	20.7	*3/4" MPT
SR048-060	H	74.5	31.4	27.0	3.7	2.0	11.1	2.0	1"	15.8	1.6	18.5	1.6	3.4	0.8	*3/4" MPT
	V	36.0	31.0	56.5	3.7	2.0	11.1	2.0	1"	15.8	1.6	18.5	1.6	1.4	22.2	*3/4" MPT

* See PDF drawings for reference

Discharge and Return Connections (inches)

Model	Cabinet Config	Discharge Connection Duct Flange Installed				Return Connection Using Return Air Opening			
		Supply Height	Supply Width	O	P	Return Width	Return Height	S	T
SR006-012	H	8.9	6.6	7.4	1.3	16.1	9.0	1.2	1.0
	V	9.0	9.0	8.2	6.2	16.1	9.0	2.1	1.0
SR015-018	H	13.1	9.6	3.9	1.2	23.0	15.0	1.1	1.0
	V	14.0	14.0	7.5	4.2	18.5	18.2	1.7	1.0
SR024-030	H	13.1	9.6	3.9	1.2	22.9	16.3	1.2	1.0
	V	14.0	14.0	7.5	4.2	18.4	18.2	1.7	1.0
SR036-042	H	16.0	11.0	2.9	2.5	26.1	19.0	1.2	1.0
	V	14.0	14.0	7.5	6.0	22.9	22.2	0.8	1.0
SR048-060	H	18.0	13.3	4.2	1.1	36.1	19.0	1.2	1.0
	V	18.0	16.0	8.5	5.7	26.2	26.2	0.8	1.0

Hanger Dimensions (inches)

Model	Cabinet Config	Unit Hanger Detail		
		U	V	W
SR006-012	H	40.3	24.6	20.3
SR015-018	H	48.1	24.6	20.3
SR024-030	H	48.1	24.6	20.3
SR036-042	H	53.1	24.6	20.3
SR048-060	H	67.8	27.6	23.4

ClimateMaster works continually to improve its products. As a result, the design and specifications of each product at the time of order may be changed without notice and may not be as described herein. Please contact ClimateMaster's Customer Service Department at 800-299-9747 for specific information on the current design and specifications. Statements and other information contained herein are not express warranties and do not form the basis of any bargain between the parties, but are merely ClimateMaster's opinion or commendation of its products. The latest version of this document is available at www.climatemaster.com. Engineered and assembled in the USA. © ClimateMaster, Inc. All Rights Reserved 2024

Standard Dimensional Data

Models:
SR
006-060

Cabinet Dimensions (cm)

Model	Cabinet Config	Depth/Length	Width	Height
		A	B	C
SR006-012	H	102.4	57.2	27.9
	V	54.1	57.2	55.9
SR015-018	H	122.9	57.2	43.2
	V	57.2	57.2	101.6
SR024-030	H	123.0	57.0	46.4
	V	57.0	57.1	101.6
SR036-042	H	135.4	57.0	53.3
	V	66.2	57.1	114.3
SR048-060	H	172.8	64.7	53.3
	V	74.4	64.7	128.3

Electrical Knockouts (cm)

Model	Cabinet Config	H	Low Voltage	High Voltage	G	Electric Heater KO	
			J KO 1/2"	K KO 3/4"		X	Y
SR006-012	H	9.1	15.0	22.6	2.8		
	V	9.1	15.0	20.6	2.8		
SR015-018	H	10.4	18.0	37.6	3.3	3.8	9.9
	V	10.4	18.0	37.6	3.3	4.2	6.8
SR024-030	H	10.5	18.1	37.5	3.2	3.8	13.0
	V	10.5	17.0	37.5	3.2	4.2	6.8
SR036-042	H	10.5	18.1	40.1	3.2	2.9	15.9
	V	10.5	18.1	40.1	3.2	4.2	6.8
SR048-060	H	10.5	18.1	42.4	3.2	3.8	15.9
	V	10.5	18.1	42.4	3.2	5.8	8.4

Shipping and Water Connections (cm)

Model	Cabinet Config	Shipping Overall Dimensions			Water Connections								Condensate Drain Pan			
		Depth/Length	Width	Height	Water In		Water Out		Water In/Out	HWG In		HWG Out		AA	BB	Condensate Drain Pan Fitting
					D	E	F	E		DD	EE	FF	EE			
SR006-012	H	116.8	72.1	43.2	9.4	3.8	21.8	3.8	1/2"					8.4	1.5	*3/4" MPT
	V	68.6	71.1	71.1	9.4	3.8	21.8	3.8	1/2"					3.8	29.7	*3/4" MPT
SR015-018	H	135.9	72.1	58.4	9.4	5.1	24.9	5.1	1/2"	32.0	4.1	37.8	4.1	8.4	2.3	*3/4" MPT
	V	69.2	69.2	116.8	9.4	5.1	24.9	5.1	3/4"	32.0	4.1	37.8	4.1	3.8	50.0	*3/4" MPT
SR024-30	H	135.9	72.1	61.6	9.5	5.1	24.8	5.1	3/4"	33.3	4.0	40.2	4.0	8.6	2.1	*3/4" MPT
	V	69.2	69.2	116.8	9.5	5.1	24.8	5.1	3/4"	33.3	4.0	40.2	4.0	3.7	50.1	*3/4" MPT
SR036-042	H	148.6	72.1	68.6	9.5	5.1	28.1	5.1	3/4"	37.7	4.0	44.7	4.0	8.6	2.1	*3/4" MPT
	V	78.7	71.1	129.5	9.5	5.1	28.1	5.1	1"	37.7	4.0	44.7	4.0	3.7	52.5	*3/4" MPT
SR048-060	H	189.2	79.7	68.6	9.5	5.1	28.1	5.1	1"	40.0	4.0	47.0	4.0	8.6	2.1	*3/4" MPT
	V	91.4	78.7	143.5	9.5	5.1	28.1	5.1	0.0	40.0	4.0	47.0	4.0	3.7	56.4	*3/4" MPT

* See PDF drawings for reference

Discharge and Return Connections (cm)

Model	Cabinet Config	Discharge Connection Duct Flange Installed				Return Connection Using Return Air Opening			
		Supply Height	Supply Width	O	P	Return Width	Return Height	S	T
SR006-012	H	22.6	16.8	18.8	3.3	40.9	22.9	3.0	2.5
	V	22.9	22.9	20.8	15.7	40.9	22.9	5.3	2.5
SR015-018	H	33.3	24.4	9.9	3.0	58.4	38.1	2.8	2.5
	V	35.6	35.6	19.1	10.7	47.0	46.2	4.3	2.5
SR024-030	H	33.3	24.5	10.0	3.0	58.3	41.3	3.1	2.5
	V	35.6	35.5	19.1	10.7	46.7	46.3	4.4	2.5
SR036-042	H	40.6	27.9	7.4	6.4	66.2	48.3	3.0	2.5
	V	35.6	35.5	19.0	15.3	58.2	56.5	2.1	2.5
SR048-060	H	45.8	33.9	10.3	3.0	91.6	48.3	3.0	2.5
	V	45.7	40.6	21.5	14.4	66.5	66.7	2.1	2.5

Hanger Dimensions (cm)

Model	Cabinet Config	Unit Hanger Detail		
		U	V	W
SR006-012	H	102.4	62.5	51.6
SR015-018	H	122.9	61.0	54.4
SR024-030	H	122.3	62.4	51.5
SR036-042	H	134.7	62.4	51.6
SR048-060	H	172.2	70.0	59.3

ClimateMaster works continually to improve its products. As a result, the design and specifications of each product at the time of order may be changed without notice and may not be as described herein. Please contact ClimateMaster's Customer Service Department at 800-299-9747 for specific information on the current design and specifications. Statements and other information contained herein are not express warranties and do not form the basis of any bargain between the parties, but are merely ClimateMaster's opinion or commendation of its products. The latest version of this document is available at www.climatemaster.com. Engineered and assembled in the USA. © ClimateMaster, Inc. All Rights Reserved 2024

HGRH, Hybrid, and WSE Extended Cabinet Dimensional Data

Models:
SR
006-060

HGRH, Hybrid, and WSE Notes:

- HGRH available in sizes 018-060 (Horizontal and Vertical)
- Hybrid available in sizes 024-060 (Horizontal only)
- WSE available in sizes 036-060 (Horizontal and Vertical)

Cabinet Dimensions (inches)

Model size	Cabinet Config.	Overall Cabinet		
		Depth/Length	Width	Height
		A	B	C
SR018	H	50.5	25.6	18.2
	V	25.5	25.5	40.0
SR024-030	H	50.5	25.6	18.2
	V	25.5	25.5	40.0
SR036-042	H	56.3	25.6	21.0
	V	29.0	25.5	45.0
SR048-060	H	70.9	28.5	21.0
	V	32.3	28.5	50.5

Electrical Knockouts (inches)

Model size	Cabinet Config.	Electrical Knockouts				Electric Heater KO	
		H	Low Voltage	High Voltage	G	X	Y
			J KO 1/2"	K KO 3/4"			
SR018	H	4.1	7.1	14.8	1.3	1.5	5.1
	V	4.1	7.1	14.8	1.3	1.7	2.7
SR024-030	H	4.1	7.1	14.8	1.3	1.5	5.1
	V	4.1	7.1	14.8	1.3	1.7	2.7
SR036-042	H	4.1	7.1	15.8	1.3	1.2	6.3
	V	4.1	7.1	15.8	1.3	1.7	2.7
SR048-060	H	4.1	7.1	16.7	1.3	1.5	6.3
	V	4.1	7.1	16.7	1.3	2.3	3.3

Shipping and Water Connections (inches)

Model size	Cabinet Config.	Shipping Overall Dimensions			Water Connections					Condensate Drain Pan Connections		
		Depth/Length	Width	Height	Water In		Water Out		Water In/Out, FPT	AA	BB	Condensate Drain Pan Fitting, MPT
					D	E	F	E				
SR018	H	51.5	32.4	24.2	3.7	2.1	9.8	2.0	1/2"	5.6	0.7	3/4"
	V	30.8	28.8	46.0	3.7	2.0	9.8	2.0	1/2"	1.5	19.7	3/4"
SR024-030	H	51.5	32.4	24.2	3.7	2.1	9.8	2.0	3/4"	5.6	0.7	3/4"
	V	30.8	28.8	46.0	3.7	2.0	9.8	2.0	3/4"	1.5	19.7	3/4"
SR036-042	H	57.3	32.4	27.0	3.7	2.0	11.1	2.0	3/4"	5.8	0.6	3/4"
	V	30.5	32.8	51.0	3.7	2.0	11.1	2.0	3/4"	1.4	20.7	3/4"
SR048-060	H	73.4	35.4	27.0	3.7	2.0	11.1	2.0	1"	5.6	0.9	3/4"
	V	32.5	41.3	56.5	3.7	2.0	11.1	2.0	1"	1.5	22.2	3/4"

Discharge and Return Connections (inches)

Model size	Cabinet Config.	Discharge Connection Duct Flange Installed				Return Connection Using Return Air Opening			
		Supply Height	Supply Width	O	P	Return Width	Return Height	S	T
SR018	H	13.1	9.6	4.0	1.2	23.0	16.3	1.2	1.0
	V	14.0	14.0	6.1	5.8	18.5	18.2	1.7	1.0
SR024-030	H	13.1	9.6	4.0	1.2	23.0	16.3	1.2	1.0
	V	14.0	14.0	6.1	5.8	18.5	18.2	1.7	1.0
SR036-042	H	16.0	11.0	3.0	2.5	26.1	19.0	1.2	1.0
	V	14.0	14.0	9.7	7.5	23.0	22.2	0.8	1.0
SR048-060	H	15.9	13.5	4.1	1.2	36.1	19.0	1.2	1.0
	V	18.0	16.0	10.3	7.2	26.3	26.2	0.8	1.0

Hanger Dimensions (inches)

Model size	Cabinet Config.	Unit Hanger Detail		
		U	V	W
SR018	H	50.2	27.6	23.4
SR024-030	H	50.2	27.6	23.4
SR036-042	H	56.1	27.6	23.4
SR048-060	H	70.7	30.6	26.4

ClimateMaster works continually to improve its products. As a result, the design and specifications of each product at the time of order may be changed without notice and may not be as described herein. Please contact ClimateMaster's Customer Service Department at 800-299-9747 for specific information on the current design and specifications. Statements and other information contained herein are not express warranties and do not form the basis of any bargain between the parties, but are merely ClimateMaster's opinion or commendation of its products. The latest version of this document is available at www.climatemaster.com. Engineered and assembled in the USA. © ClimateMaster, Inc. All Rights Reserved 2024

HGRH, Hybrid, and WSE Extended Cabinet Dimensional Data

Models:
SR
006-060

HGRH, Hybrid, and WSE Notes:

- HGRH available in sizes 018-060 (Horizontal and Vertical)
- Hybrid available in sizes 024-060 (Horizontal only)
- WSE available in sizes 036-060 (Horizontal and Vertical)

Cabinet Dimensions (cm)

Model size	Cabinet Config.	Overall Cabinet		
		Depth/Length	Width	Height
		A	B	C
SR018	H	128.3	65.0	46.2
	V	64.8	64.8	101.6
SR024-030	H	128.3	65.0	46.2
	V	64.8	64.8	101.6
SR036-042	H	143.0	65.0	53.3
	V	73.7	64.8	114.3
SR048-060	H	180.1	72.4	53.3
	V	82.0	72.4	128.3

Electrical Knockouts (cm)

Model size	Cabinet Config.	Electrical Knockouts				Electric Heater KO	
		H	Low Voltage	High Voltage	G	X	Y
			J KO 1/2"	K KO 3/4"			
SR018	H	4.1	7.1	14.8	1.3	1.5	5.1
	V	4.1	7.1	14.8	1.3	1.7	2.7
SR024-030	H	4.1	7.1	14.8	1.3	1.5	5.1
	V	4.1	7.1	14.8	1.3	1.7	2.7
SR036-042	H	4.1	7.1	15.8	1.3	1.2	6.3
	V	4.1	7.1	15.8	1.3	1.7	2.7
SR048-060	H	4.1	7.1	16.7	1.3	1.5	6.3
	V	4.1	7.1	16.7	1.3	2.3	3.3

Shipping and Water Connections (cm)

Model size	Cabinet Config.	Shipping Overall Dimensions			Water Connections					Condensate Drain Pan Connections		
		Depth/Length	Width	Height	Water In		Water Out		Water In/Out, FPT	AA	BB	Condensate Drain Pan Fitting, MPT
					D	E	F	E				
SR018	H	130.8	82.2	61.5	9.4	5.3	24.9	5.1	1/2"	14.2	1.8	3/4"
	V	78.1	73.0	116.8	9.4	5.1	24.9	5.1	3/4"	3.8	50.0	3/4"
SR024-030	H	130.8	82.2	61.5	9.5	5.3	24.8	5.1	3/4"	14.2	1.8	3/4"
	V	78.1	73.0	116.8	9.5	5.1	24.8	5.1	3/4"	3.8	50.1	3/4"
SR036-042	H	145.4	82.2	68.6	9.5	5.1	28.1	5.1	3/4"	14.7	1.5	3/4"
	V	77.5	83.2	129.5	9.5	5.1	28.1	5.1	3/4"	3.7	52.5	3/4"
SR048-060	H	186.4	89.9	68.6	9.5	5.1	28.1	5.1	1"	14.2	2.3	3/4"
	V	82.6	104.8	143.5	9.5	5.1	28.1	5.1	1"	3.8	56.4	3/4"

Discharge and Return Connections (cm)

Model size	Cabinet Config.	Discharge Connection Duct Flange Installed				Return Connection Using Return Air Opening			
		Supply Height	Supply Width	O	P	Return Width	Return Height	S	T
SR018	H	33.3	24.4	10.2	3.0	58.4	41.4	3.0	2.5
	V	35.6	35.6	15.5	14.7	47.0	46.2	4.3	2.5
SR024-030	H	33.3	24.5	10.2	3.0	58.4	41.3	3.1	2.5
	V	35.6	35.5	15.5	14.7	47.0	46.3	4.4	2.5
SR036-042	H	40.6	27.9	7.6	6.4	66.2	48.3	3.0	2.5
	V	35.6	35.5	24.6	19.1	58.4	56.5	2.1	2.5
SR048-060	H	40.4	34.4	10.3	3.0	91.6	48.3	3.0	2.5
	V	45.7	40.6	26.2	18.3	66.8	66.7	2.1	2.5

Hanger Dimensions (cm)

Model size	Cabinet Config.	Unit Hanger Detail		
		U	V	W
SR018	H	50.2	27.6	23.4
SR024-030	H	50.2	27.6	23.4
SR036-042	H	56.1	27.6	23.4
SR048-060	H	70.7	30.6	26.4

ClimateMaster works continually to improve its products. As a result, the design and specifications of each product at the time of order may be changed without notice and may not be as described herein. Please contact ClimateMaster's Customer Service Department at 800-299-9747 for specific information on the current design and specifications. Statements and other information contained herein are not express warranties and do not form the basis of any bargain between the parties, but are merely ClimateMaster's opinion or commendation of its products. The latest version of this document is available at www.climatemaster.com. Engineered and assembled in the USA. © ClimateMaster, Inc. All Rights Reserved 2024

Horizontal Cabinet Corner Weights

Models:
SR
006-060

Standard Corner Weights (lb)

Model	Left - Front	Right - Front	Left - Back	Right/Back
SR006	40.0	20.0	25.0	25.0
SR009	41.0	21.0	25.0	25.0
SR012	45.0	22.0	27.0	27.0
SR015	54.0	44.0	33.0	33.0
SR018	55.0	45.0	34.0	34.0
SR024	61.0	50.0	37.0	37.0
SR030	63.0	52.0	38.0	38.0
SR036	70.0	58.0	43.0	43.0
SR042	75.0	62.0	46.0	46.0
SR048	93.0	76.0	57.0	57.0
SR060	98.0	80.0	60.0	60.0

Standard Corner Weights (kg)

Model	Left - Front	Right - Front	Left - Back	Right/Back
SR006	18.1	9.1	11.3	11.3
SR009	18.6	9.5	11.3	11.3
SR012	20.4	10.0	12.2	12.2
SR015	24.5	20.0	15.0	15.0
SR018	24.9	20.4	15.4	15.4
SR024	27.7	22.7	16.8	16.8
SR030	28.6	23.6	17.2	17.2
SR036	31.8	26.3	19.5	19.5
SR042	34.0	28.1	20.9	20.9
SR048	42.2	34.5	25.9	25.9
SR060	44.5	36.3	27.2	27.2

Hybrid Corner Weights (lb)

Model	Left - Front	Right - Front	Left - Back	Right/Back
SR024	83.0	68.0	51.0	51.0
SR030	86.0	71.0	52.0	52.0
SR036	101.0	84.0	62.0	62.0
SR042	106.0	88.0	65.0	65.0
SR048	123.0	100.0	75.0	75.0
SR060	132.0	109.0	82.0	82.0

Hybrid Corner Weights (kg)

Model	Left - Front	Right - Front	Left - Back	Right/Back
SR024	37.6	30.8	23.1	23.1
SR030	39.0	32.2	23.6	23.6
SR036	45.8	38.1	28.1	28.1
SR042	48.1	39.9	29.5	29.5
SR048	55.8	45.4	34.0	34.0
SR060	60.0	49.4	37.2	37.2

Hot Gas Reheat Corner Weights (lb)

Model	Left - Front	Right - Front	Left - Back	Right/Back
SR018	83.0	68.0	51.0	51.0
SR024	83.0	68.0	51.0	51.0
SR030	86.0	71.0	52.0	52.0
SR036	101.0	84.0	62.0	62.0
SR042	106.0	88.0	65.0	65.0
SR048	123.0	100.0	75.0	75.0
SR060	132.0	109.0	82.0	82.0

Hot Gas Reheat Corner Weights (kg)

Model	Left - Front	Right - Front	Left - Back	Right/Back
SR018	37.6	30.8	23.1	23.1
SR024	37.6	30.8	23.1	23.1
SR030	39.0	32.2	23.6	23.6
SR036	45.8	38.1	28.1	28.1
SR042	48.1	39.9	29.5	29.5
SR048	55.8	45.4	34.0	34.0
SR060	60.0	49.4	37.2	37.2

Left Hand WSE Corner Weights (lb)

Model	Left - Front	Right - Front	Left - Back	Right/Back
SR036	115.0	72.0	67.0	57.0
SR042	121.0	75.0	72.0	58.0
SR048	139.0	85.0	82.0	66.0
SR060	131.0	82.0	78.0	96.0

Horizontal Cabinet Corner Weights

Models:
SR
006-060

Left Hand WSE Corner Weights (kg)

Model	Left - Front	Right - Front	Left - Back	Right/Back
SR036	52.1	32.7	30.4	25.9
SR042	54.9	34.0	32.7	26.3
SR048	63.0	38.6	37.2	29.9
SR060	59.4	37.2	35.4	43.5

Right Hand WSE Corner Weights (lb)

Model	Left - Front	Right - Front	Left - Back	Right/Back
SR036	72.0	115.0	57.0	67.0
SR042	75.0	121.0	58.0	72.0
SR048	85.0	139.0	66.0	82.0
SR060	82.0	131.0	96.0	78.0

Right Hand WSE Corner Weights (kg)

Model	Left - Front	Right - Front	Left - Back	Right/Back
SR036	32.7	52.2	25.9	30.4
SR042	34.0	54.9	26.3	32.7
SR048	38.6	63.0	29.9	37.2
SR060	37.2	59.4	43.5	35.4

Horizontal Dimensional Data

Models:
SR
006-060

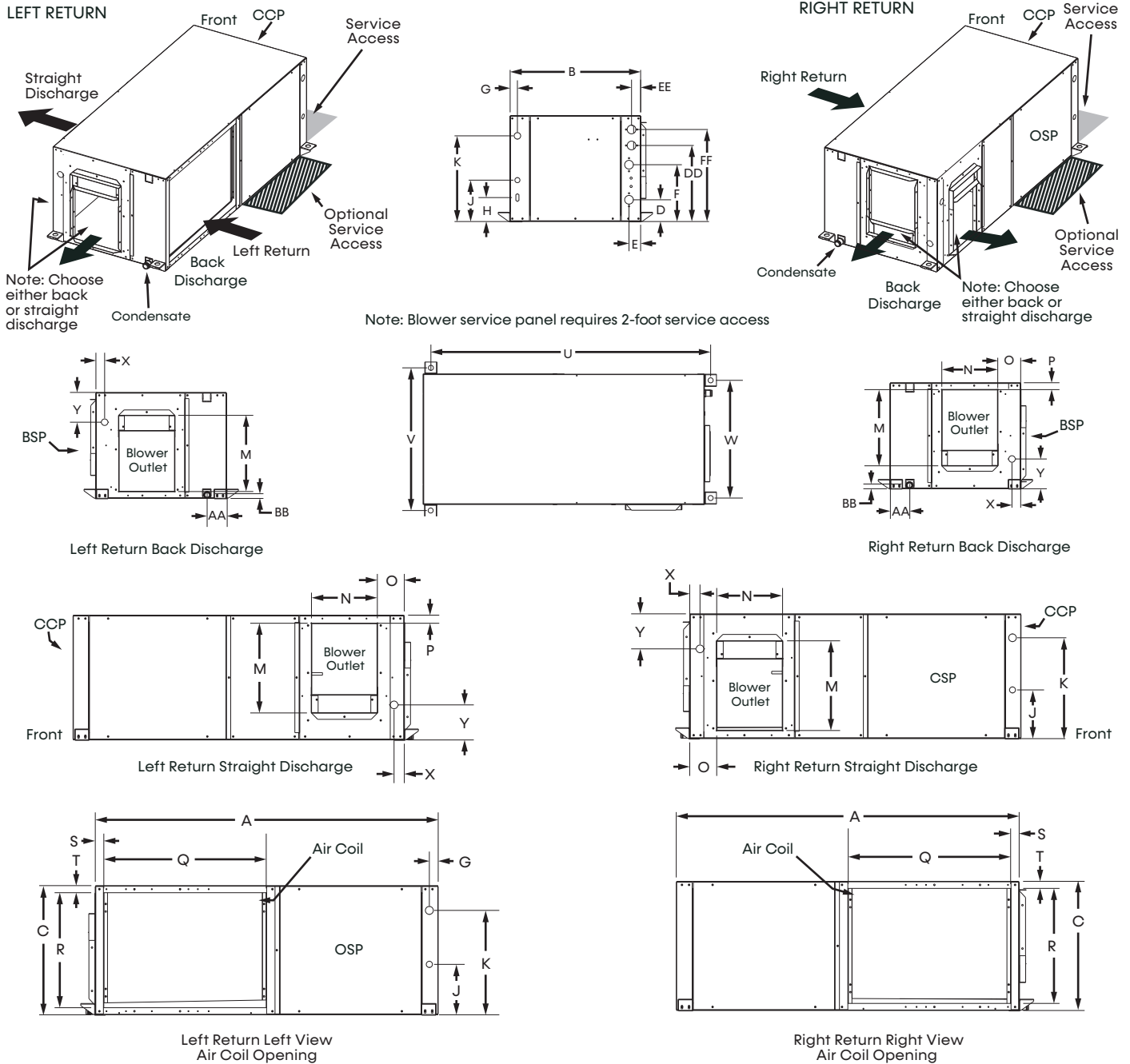

Notes:

1. While clear access to all removable panels is not required, installer should take care to comply with all building codes and allow adequate clearance for future field service.
2. Units come standard with air filter rails. For duct connections, order optional filter frames. See product options decoder for details. You can convert filter rails in the field with an accessory air filter frame kit. Please see the accessory submittal for details.
3. Discharge flange and hanger brackets are factory installed.
4. Condensate is a rubber coupling that couples to 3/4-inch schedule 40/80 PVC.
5. Blower service panel requires 2-foot service access.
6. Blower service access is through back panel on straight discharge units or through panel opposite air coil on back discharge units.
7. Water connections for optional hot water generator are 1/2-inch FPT.
8. OSP are removable panels that provide additional access to the units interior. Clear access to OSP panels is not required and they are not to be used in place of the mandatory CCP and BSP panels.

Legend:

- CCP = Control/Compressor Access
- BSP = Blower Service Panel
- OSP = Optional Service Panel (not required)

Extended Cabinet (HGRH, Hybrid, WSE) Horizontal Dimensional Data

Models:
SR
006-060

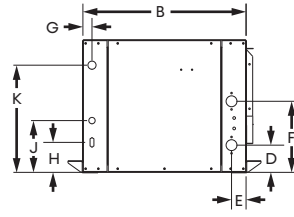
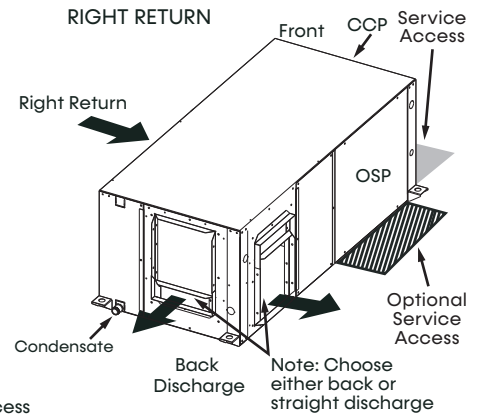
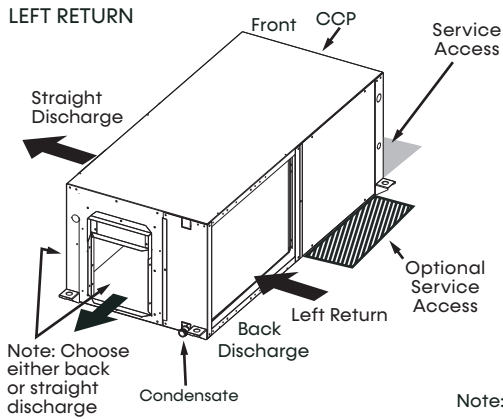

Note: Blower service panel requires 2-foot service access

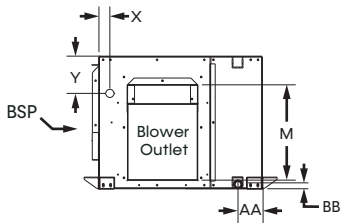

Left Return Back Discharge

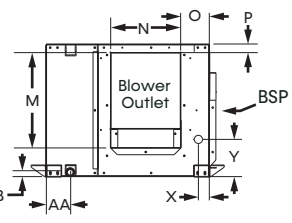
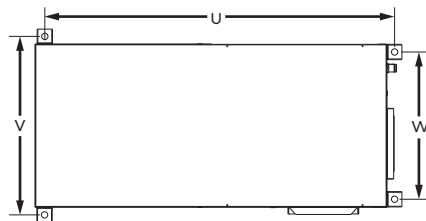

Right Return Back Discharge

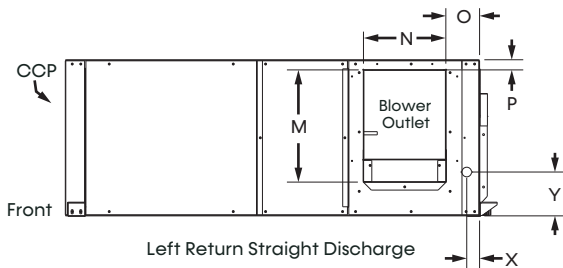

Left Return Straight Discharge

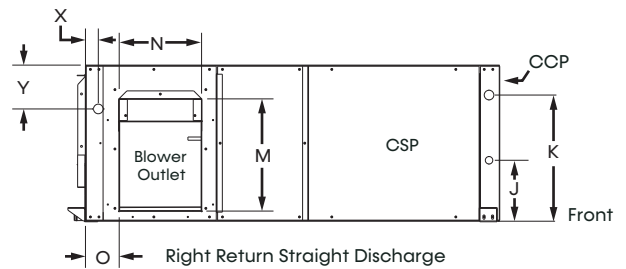

Right Return Straight Discharge

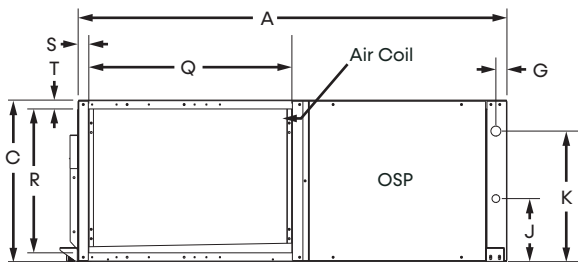

Left Return Left View
Air Coil Opening

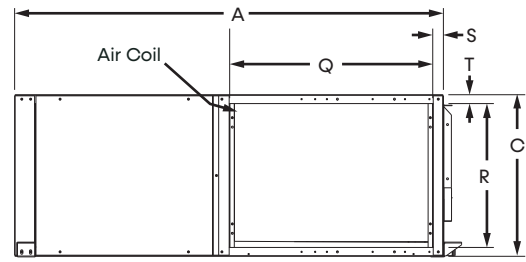

Right Return Right View
Air Coil Opening

Notes:

1. While clear access to all removable panels is not required, installer should take care to comply with all building codes and allow adequate clearance for future field service.
2. Units come standard with air filter rails. For duct connections, order optional filter frame kits. See product options decoder for details. You can convert filter rails in the field with an accessory air filter frame kit. Please see the accessory submittal for details.
3. Discharge flange and hanger brackets are factory installed.
4. Condensate is a rubber coupling that couples to 3/4-inch schedule 40/80 PVC.
5. Blower service panel requires 2-foot service access.
6. Blower service access is through back panel on straight discharge units or through panel opposite air coil on back discharge units.
7. Water connections for optional hot water generator are 1/2-inch FPT.
8. OSP are removable panels that provide additional access to the units interior. Clear access to OSP panels is not required and they are not to be used in place of the mandatory CCP and BSP panels.
9. The HWG option is not available with the WSE, Hybrid, or HGRH option.

Legend:

- CCP = Control/Compressor Access
- BSP = Blower Service Panel
- OSP = Optional Service Panel (not required)

Horizontal Service Access

Models:
SR
006-060

Left Return Back Discharge

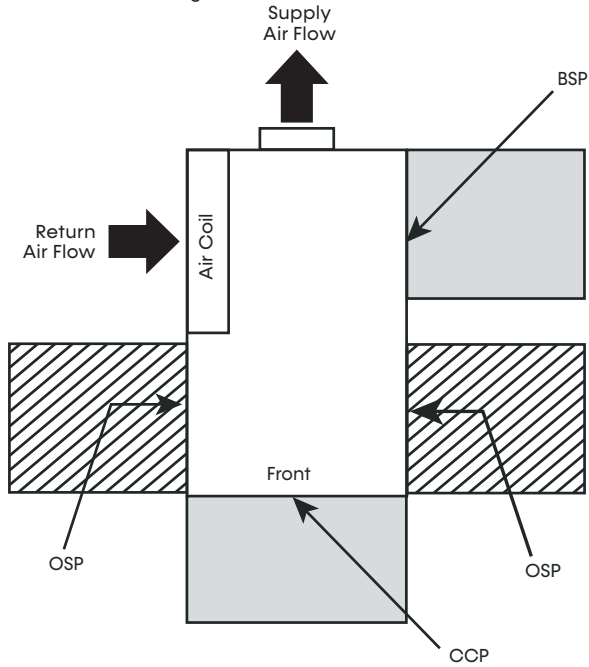

Right Return Back Discharge

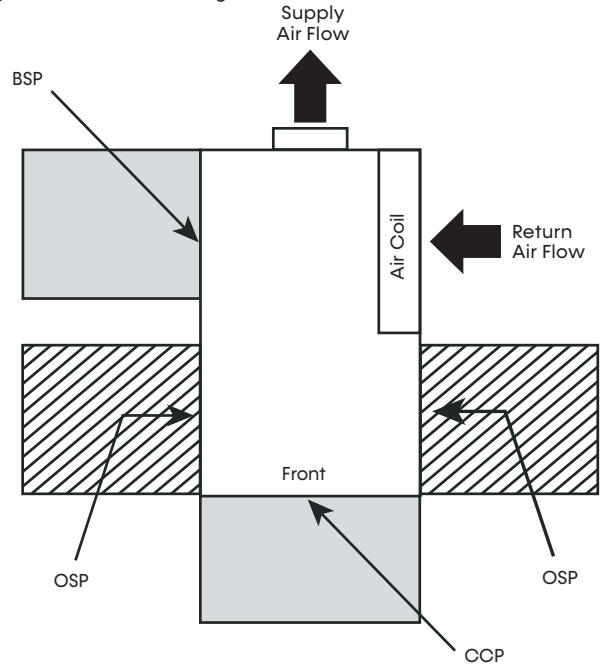

Left Return Straight Discharge

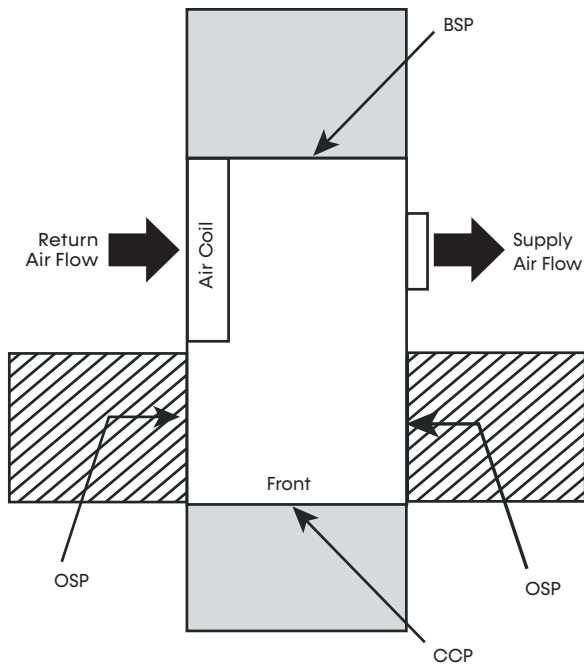

Right Return Straight Discharge

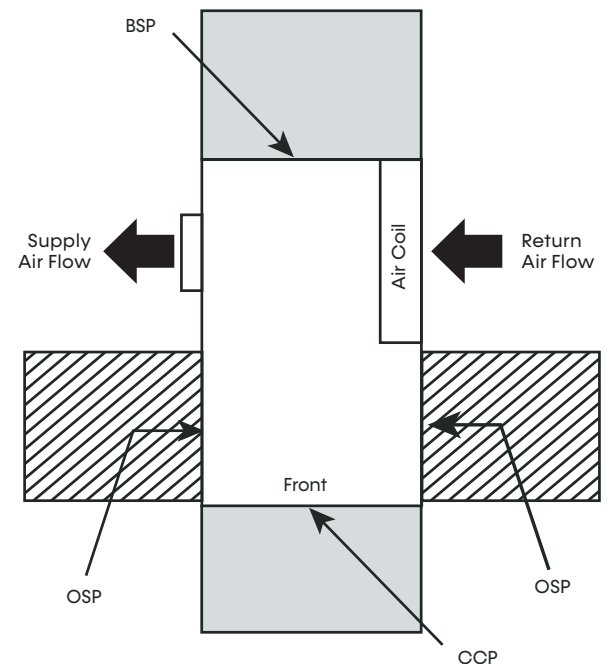

Notes:

1. While clear access to all removable panels is not required, installer should take care to comply with all building codes and allow adequate clearance for future field service.
2. CCP and BSP requires 2-feet of service access.
3. Blower service access is through back panel on straight discharge units or through panel opposite air coil on back discharge units.
4. OSP are removable panels that provide additional access to the units interior. Clear access to OSP panels is not required and they are not to be used in place of the mandatory CCP and BSP panels.

 = Mandatory Service Access 2-foot (61 cm)

 = Optional Service Access 2-foot (61 cm)

Legend:

CCP = Control/Compressor Access

BSP = Blower Service Panel

OSP = Optional Service Panel (not required)

Vertical Upflow Dimensional Data

Models:
SR
006-060

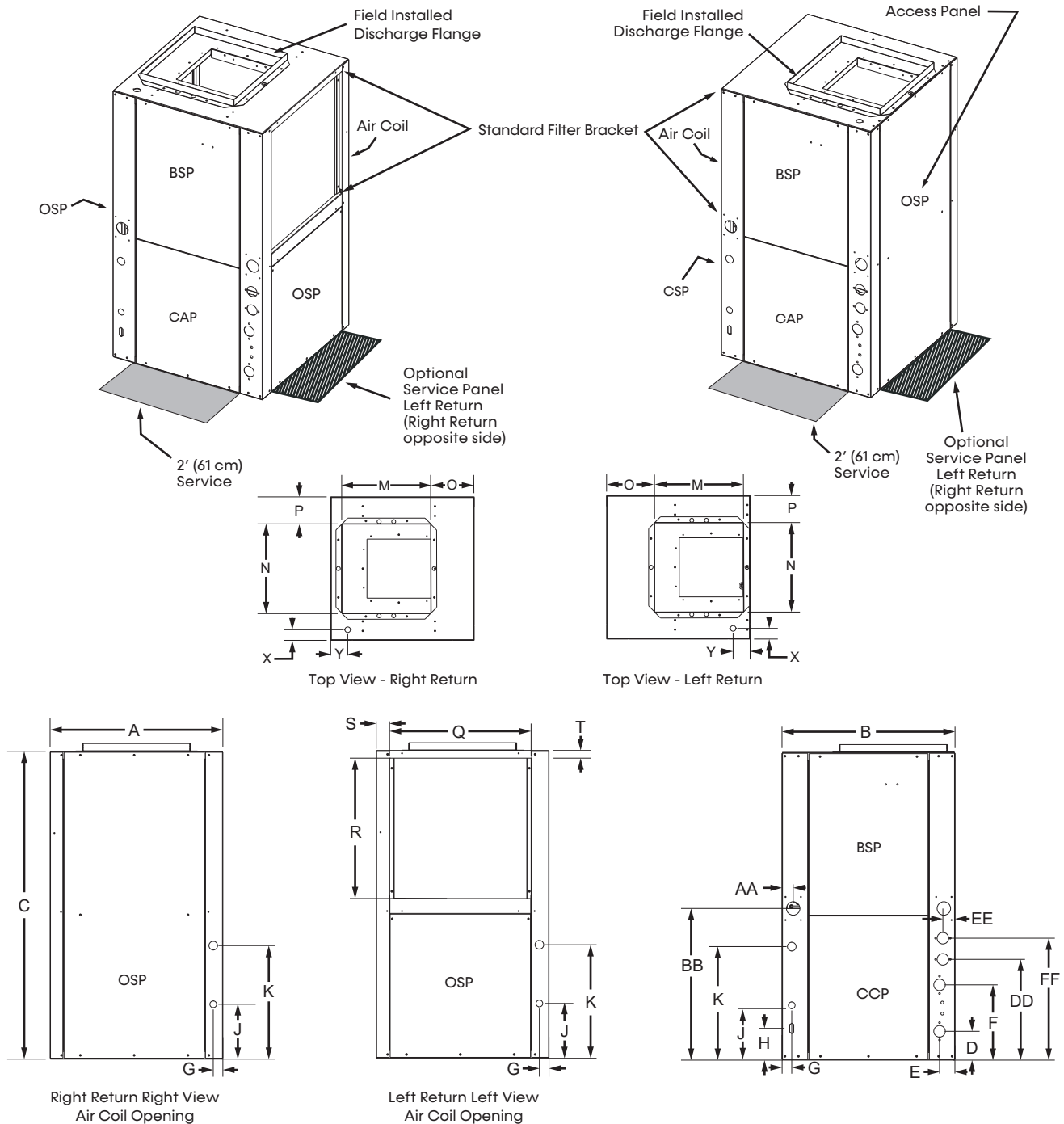

Notes:

1. While clear access to all removable panels is not required, installer should take care to comply with all building codes and allow adequate clearance for future field service.
2. Front and Side access is preferred for service access. However, all components may be serviced from the front access panel if side access is not available.
3. Discharge flange is field installed.
4. Condensate is rubber coupling that couples to 3/4-inch schedule 40/80 PVC.
5. Water connections for optional hot water generator are 1/2-inch FPT.
6. Units come standard with air filter rails. For duct connections, optional filter frames should be ordered. See product options decoder for details. Filter rails can be converted in the field with an accessory air filter frame kit. Please see the accessory submittal for details.

Legend:

- CCP = Control/Compressor Access
- BSP = Blower Service Panel
- OSP = Optional Service Panel (not required)

ClimateMaster works continually to improve its products. As a result, the design and specifications of each product at the time of order may be changed without notice and may not be as described herein. Please contact ClimateMaster's Customer Service Department at 800-299-9747 for specific information on the current design and specifications. Statements and other information contained herein are not express warranties and do not form the basis of any bargain between the parties, but are merely ClimateMaster's opinion or commendation of its products. The latest version of this document is available at www.climatemaster.com. Engineered and assembled in the USA. © ClimateMaster, Inc. All Rights Reserved 2024

Extended Cabinet (HGRH, Hybrid, WSE) Vertical Upflow Dimensional Data

Models:
SR
006-060

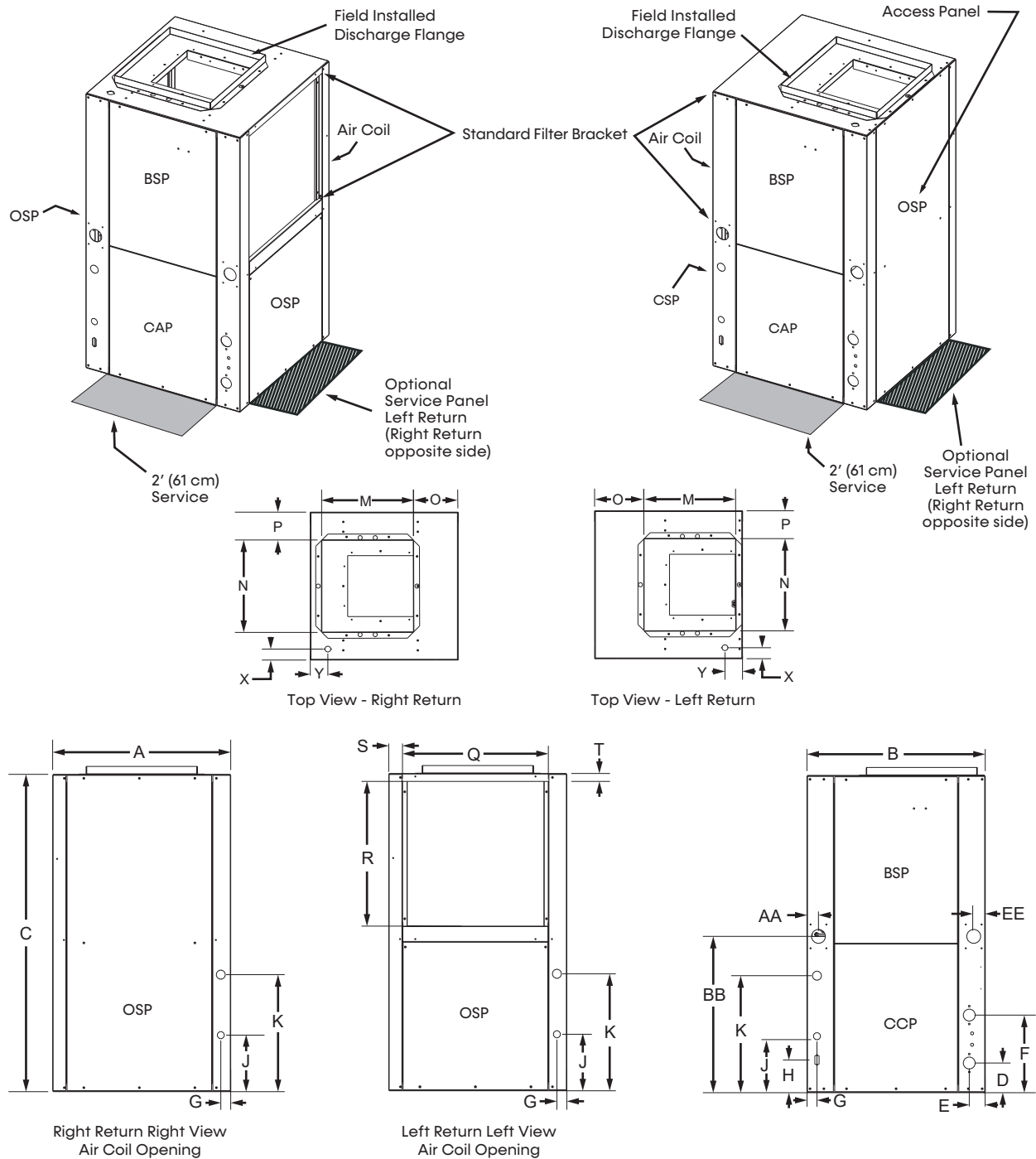

Notes:

1. While clear access to all removable panels is not required, installer should take care to comply with all building codes and allow adequate clearance for future field service.
2. Front and Side access is preferred for service access. However, all components may be serviced from the front access panel if side access is not available.
3. Discharge flange is field installed.
4. Condensate is rubber coupling that couples to 3/4-inch schedule 40/80 PVC.
5. Water connections for optional hot water generator are 1/2-inch FPT.
6. Units come standard with air filter rails. For duct connections, optional filter frames should be ordered. See product options decoder for details. Filter rails can be converted in the field with an accessory air filter frame kit. Please see the accessory submittal for details.
7. The HWG option is not available with the WSE, Hybrid, or HGRH option.

Legend:

- CCP = Control/Compressor Access
- BSP = Blower Service Panel
- OSP = Optional Service Panel (not required)

ClimateMaster works continually to improve its products. As a result, the design and specifications of each product at the time of order may be changed without notice and may not be as described herein. Please contact ClimateMaster's Customer Service Department at 800-299-9747 for specific information on the current design and specifications. Statements and other information contained herein are not express warranties and do not form the basis of any bargain between the parties, but are merely ClimateMaster's opinion or commendation of its products. The latest version of this document is available at www.climatemaster.com. Engineered and assembled in the USA. © ClimateMaster, Inc. All Rights Reserved 2024

Left Return

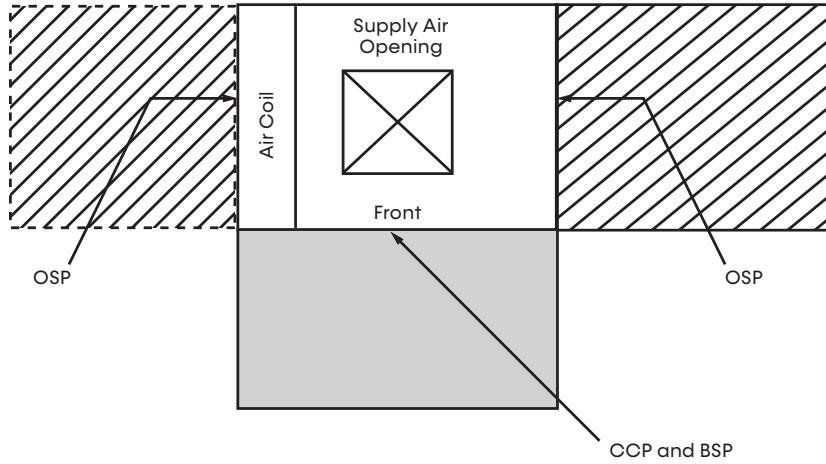

Right Return

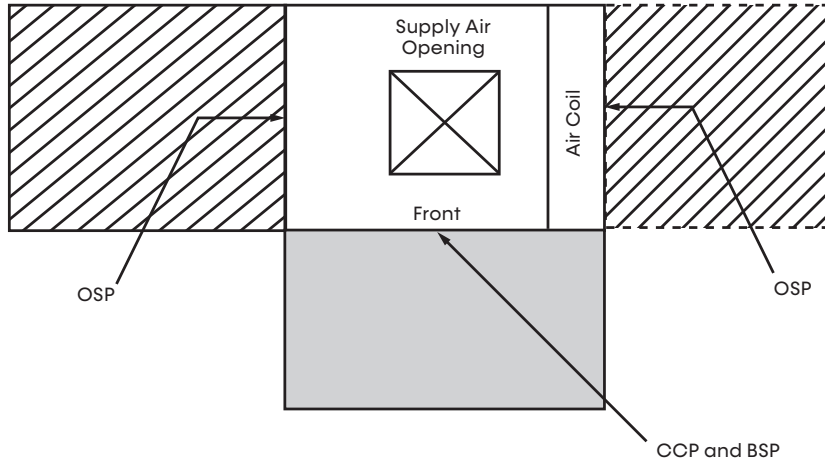

Notes:

1. While clear access to all removable panels is not required, installer should take care to comply with all building codes and allow adequate clearance for future field service.
2. Front and side access is preferred for service access. However, all components may be serviced from the front access panel if side access is not available.
3. OSP are removable panels that provide additional access to the units interior. Clear access to OSP panels is not required and they are not to be used in place of the mandatory CCP and BSP panels.
4. Top supply air is shown, the same clearances apply to bottom supply air units.

 = Mandatory Service Access 2-foot (61 cm)

 = Optional Service Access 2-foot (61 cm)

Legend:

CCP = Control/Compressor Access

BSP = Blower Service Panel

OSP = Optional Service Panel (not required)

MINIMUM INSTALLATION AREA

Minimum area where a blower-equipped unit must be installed, and mechanical/natural ventilation is not required

Model	Charge (oz)	Configuration	Minimum Installation Area ft ² (m ²) [A _{min}]			
			Floor	Window	Wall	Ceiling
SR060	69	Vertical	237 (22.0)	132 (12.2)	76 (7.0)	63 (5.9)
		Horizontal	237 (22.0)	141 (13.1)	79 (7.3)	65 (6.0)

A _{min} =	Minimum area where unit is installed where unit has incorporated airflow
h _{inst} (floor) =	0.0 ft (0.0 m)
h _{inst} (window) =	3.3 ft (1.0 m)
h _{inst} (wall) =	5.9 ft (1.8 m)
h _{inst} (ceiling) =	7.2 ft (2.2 m)

Minimum area and CFM requirements for the conditioned space

Model	Charge (oz)	Minimum CFM [Q _{min}]	
		TA _{min} (ft ²)	Q _{min} (ft ³ /min)
SR060	69	3.54	117

TA _{min} =	Minimum conditioned area for venting leaked refrigerant
Q _{min} =	Minimum ventilation flow rate for conditioned space if space is less than TA _{min}

Minimum area of opening for natural ventilation

Model	Charge (oz)	Anv _{min} in ² (m ²)
SR060	69	111.57 (0.07)

Anv _{min} =	Minimum natural ventilation area opening
----------------------	--

When the openings for connected rooms or natural ventilation are required, the following conditions shall be applied:

- The area of any openings above 11.8 inches (300 mm) from the floor shall not be considered in determining compliance with Anv_{min}.
- At least 50% of the required opening area Anv_{min} shall be below 7.8 inches (200 mm) from the floor.
- The bottom of the lowest openings shall not be higher than the point of release when the unit is installed and not more than 3.9 inches (100 mm) from the floor.
- Openings are permanent openings which cannot be closed.
- For openings extending to the floor, the height shall not be less than 0.78 inch (20 mm) above the surface of the floor covering.
- A second higher opening shall be provided. The total size of the second opening shall not be less than 50% of minimum opening area for Anv_{min} and shall be at least 3.3 ft (1.5 m) above the floor.

Electrical Data

PSC Blower Motor Standard Unit

Models:
SR
006-060

Model	VOLTAGE CODE	VOLTAGE	VOLTAGE MIN/MAX	COMPRESSOR			FAN MOTOR FLA	TOTAL UNIT FLA	MIN CIRCUIT AMP	FUSE/HACR AMP
				QTY	RLA	LRA				
SR006	G.J.	208/230-1-60	187/252	1	3.7	17.7	0.3	4.0	4.9	15
	E.D.	265-1-60	249/291	1	2.6	10.5	0.4	3.0	3.7	15
SR009	G.J.	208/230-1-60	187/252	1	5.0	22.2	0.8	5.8	7.1	15
	E.D.	265-1-60	249/291	1	3.6	13.5	0.8	4.4	5.3	15
SR012	G.J.	208/230-1-60	187/252	1	5.6	32.5	0.8	6.4	7.8	15
	E.D.	265-1-60	249/291	1	4.2	23.0	0.8	5.0	6.1	15
SR015	G.J.	208/230-1-60	187/252	1	6.6	31.0	0.9	7.5	9.2	15
	E.D.	265-1-60	249/291	1	5.0	27.0	0.7	5.7	7.0	15
SR018	G.J.	208/230-1-60	187/252	1	7.0	35.0	0.9	7.9	9.7	15
	E.D.	265-1-60	249/291	1	6.5	40.0	0.7	7.2	8.8	15
SR024	G.J.	208/230-1-60	187/252	1	11.4	64.4	1.5	12.9	15.8	25
	E.D.	265-1-60	249/291	1	10.3	60.5	1.2	11.5	14.1	20
	H.K.	208/230-3-60	187/252	1	7.7	59.9	1.5	9.2	11.1	15
	F.L.	460-3-60	432/504	1	3.8	32.4	0.8	4.6	5.5	15
SR030	G.J.	208/230-1-60	187/252	1	12.7	75.6	2.7	15.4	18.6	30
	E.D.	265-1-60	249/291	1	11.5	84.0	2.9	14.4	17.3	25
	H.K.	208/230-3-60	187/252	1	9.6	67.7	2.7	12.3	14.7	20
	F.L.	460-3-60	432/504	1	4.5	38.1	1.6	6.1	7.2	15
SR036	G.J.	208/230-1-60	187/252	1	14.4	86.0	2.6	17.0	20.6	35
	E.D.	265-1-60	249/291	1	10.2	55.0	2.0	12.2	14.8	25
	H.K.	208/230-3-60	187/252	1	9.0	70.0	2.6	11.6	13.9	20
	F.L.	460-3-60	432/504	1	4.1	39.0	1.2	5.3	6.3	15
SR042	G.J.	208/230-1-60	187/252	1	17.3	123.0	2.7	20.0	24.3	40
	H.K.	208/230-3-60	187/252	1	12.8	102.8	2.7	15.5	18.7	30
	F.L.	460-3-60	432/504	1	5.8	48.5	1.6	7.4	8.9	15
	N.M.	575-3-60	540/630	1	5.1	41.0	1.4	6.5	7.8	15
SR048	G.J.	208/230-1-60	187/252	1	22.4	126.0	3.3	25.7	31.3	50
	H.K.	208/230-3-60	187/252	1	12.8	120.4	3.3	16.1	19.3	30
	F.L.	460-3-60	432/504	1	6.0	49.4	1.7	7.7	9.2	15
	N.M.	575-3-60	540/630	1	5.8	41.0	1.4	7.2	8.7	15
SR060	G.J.	208/230-1-60	187/252	1	23.7	157.0	4.8	28.5	34.4	50
	H.K.	208/230-3-60	187/252	1	16.0	156.4	4.8	20.8	24.8	40
	F.L.	460-3-60	432/504	1	7.1	69.0	2.4	9.5	11.3	15
	N.M.	575-3-60	540/630	1	6.4	48.0	1.8	8.2	9.8	15

ClimateMaster works continually to improve its products. As a result, the design and specifications of each product at the time of order may be changed without notice and may not be as described herein. Please contact ClimateMaster's Customer Service Department at 800-299-9747 for specific information on the current design and specifications. Statements and other information contained herein are not express warranties and do not form the basis of any bargain between the parties, but are merely ClimateMaster's opinion or commendation of its products. The latest version of this document is available at www.climatemaster.com. Engineered and assembled in the USA. © ClimateMaster, Inc. All Rights Reserved 2024

PSC Blower Motor with Internal Secondary Pump

Models:
SR
006-060

Model	VOLTAGE CODE	VOLTAGE	VOLTAGE MIN/MAX	COMPRESSOR			PUMP FLA	FAN MOTOR FLA	TOTAL UNIT FLA	MIN CIRCUIT AMP	FUSE/HACR AMP
				QTY	RLA	LRA					
SR006	G.J.	208/230-1-60	187/252	1	3.7	17.7	0.4	0.3	4.4	5.3	15
	E.D.	265-1-60	249/291	1	2.6	10.5	0.7	0.4	3.7	4.4	15
SR009	G.J.	208/230-1-60	187/252	1	5.0	22.2	0.4	0.8	6.2	7.5	15
	E.D.	265-1-60	249/291	1	3.6	13.5	0.7	0.8	5.1	6.0	15
SR012	G.J.	208/230-1-60	187/252	1	5.6	32.5	0.8	0.8	7.2	8.6	15
	E.D.	265-1-60	249/291	1	4.2	23.0	0.7	0.8	5.7	6.8	15
SR015	G.J.	208/230-1-60	187/252	1	6.6	31.0	0.8	0.9	8.3	10.0	15
	E.D.	265-1-60	249/291	1	5.0	27.0	0.7	0.7	6.4	7.7	15
SR018	G.J.	208/230-1-60	187/252	1	7.0	35.0	0.8	0.9	8.7	10.5	15
	E.D.	265-1-60	249/291	1	6.5	40.0	0.7	0.7	7.9	9.5	15
SR024	G.J.	208/230-1-60	187/252	1	11.4	64.4	0.8	1.5	13.7	16.6	25
	E.D.	265-1-60	249/291	1	10.3	60.5	0.7	1.2	12.2	14.8	25
	H.K.	208/230-3-60	187/252	1	7.7	59.9	0.8	1.5	10.0	11.9	15
	F.L.	460-3-60*	432/504	1	3.8	32.4	0.7	0.8	5.3	6.2	15
SR030	G.J.	208/230-1-60	187/252	1	12.7	75.6	0.8	2.7	16.2	19.4	30
	E.D.	265-1-60	249/291	1	11.5	84.0	0.7	2.9	15.1	18.0	25
	H.K.	208/230-3-60	187/252	1	9.6	67.7	0.8	2.7	13.1	15.5	25
	F.L.	460-3-60*	432/504	1	4.5	38.1	0.7	1.6	6.8	7.9	15
SR036	G.J.	208/230-1-60	187/252	1	14.4	86.0	0.8	2.6	17.8	21.4	35
	E.D.	265-1-60	249/291	1	10.2	55.0	0.7	2.0	12.9	15.5	25
	H.K.	208/230-3-60	187/252	1	9.0	70.0	0.8	2.6	12.4	14.7	20
	F.L.	460-3-60*	432/504	1	4.1	39.0	0.7	1.2	6.0	7.0	15
SR042	G.J.	208/230-1-60	187/252	1	17.3	123.0	0.8	2.7	20.8	25.1	40
	H.K.	208/230-3-60	187/252	1	12.8	102.8	0.8	2.7	16.3	19.5	30
	F.L.	460-3-60*	432/504	1	5.8	48.5	0.7	1.6	8.1	9.6	15
	N.M.	575-3-60	540/630	1	5.1	41.0					
SR048	G.J.	208/230-1-60	187/252	1	22.4	126.0	1.1	3.3	26.8	32.4	50
	H.K.	208/230-3-60	187/252	1	12.8	120.4	1.1	3.3	17.2	20.4	30
	F.L.	460-3-60*	432/504	1	6.0	49.4	1.3	1.7	9.0	10.5	15
	N.M.	575-3-60	540/630	1	5.8	41.0					
SR060	G.J.	208/230-1-60	187/252	1	23.7	157.0	1.1	4.8	29.6	35.5	50
	H.K.	208/230-3-60	187/252	1	16.0	156.4	1.1	4.8	21.9	25.9	40
	F.L.	460-3-60*	432/504	1	7.1	69.0	1.3	2.4	10.8	12.6	15
	N.M.	575-3-60	540/630	1	6.4	48.0					

***Neutral connection required! All F and L voltage (460VAC) units with an Internal Secondary Pump require a four-wire power supply with neutral. The ISP is rated 265VAC and is wired between one hot leg and neutral.**

Electrical Data EC Blower Motor

Models:
SR
006-060

SR Electrical Table							CT EC				CV EC*			
Model	VOLTAGE CODE	VOLTAGE	VOLTAGE MIN/MAX	COMPRESSOR			FAN MOTOR FLA	TOTAL UNIT FLA	MIN CIRCUIT AMP	FUSE/HACR AMP	FAN MOTOR FLA	TOTAL UNIT FLA	MIN CIRCUIT AMP	FUSE/HACR AMP
				QTY	RLA	LRA								
SR006	G.J.	208/230-1-60	187/252	1	3.7	17.7	2.3	6.0	6.9	15	1.5	5.2	6.1	15
	E.D.	265-1-60	249/291	1	2.6	10.5	2.3	4.9	5.6	15	1.4	4.0	4.7	15
SR009	G.J.	208/230-1-60	187/252	1	5.0	22.2	2.3	7.3	8.6	15	1.5	6.5	7.8	15
	E.D.	265-1-60	249/291	1	3.6	13.5	2.3	5.9	6.8	15	1.4	5.0	5.9	15
SR012	G.J.	208/230-1-60	187/252	1	5.6	32.5	2.3	7.9	9.3	15	2.6	8.2	9.6	15
	E.D.	265-1-60	249/291	1	4.2	23.0	2.3	6.5	7.6	15	2.5	6.7	7.8	15
SR015	G.J.	208/230-1-60	187/252	1	6.6	31.0	2.6	9.2	10.9	15	2.6	9.2	10.9	15
	E.D.	265-1-60	249/291	1	5.0	27.0	1.9	6.9	8.2	15	2.4	7.4	8.7	15
SR018	G.J.	208/230-1-60	187/252	1	7.0	35.0	2.6	9.6	11.4	15	2.6	9.6	11.4	15
	E.D.	265-1-60	249/291	1	6.5	40.0	1.9	8.4	10.0	15	2.1	8.6	10.2	15
SR024	G.J.	208/230-1-60	187/252	1	11.4	64.4	3.9	15.3	18.2	25	4.2	15.6	18.5	25
	E.D.	265-1-60	249/291	1	10.3	60.5	3.7	14.0	16.6	25	3.4	13.7	16.3	25
	H.K.	208/230-3-60	187/252	1	7.7	59.9	3.9	11.6	13.5	20	4.2	11.9	13.8	20
	F.L.	460-3-60*	432/504	1	3.8	32.4	1.2	5.0	6.0	15	3.4	7.2	8.2	15
SR030	G.J.	208/230-1-60	187/252	1	12.7	75.6	3.9	16.6	19.8	30	4.2	16.9	20.1	30
	E.D.	265-1-60	249/291	1	11.5	84.0	3.7	15.2	18.1	25	3.4	14.9	17.8	25
	H.K.	208/230-3-60	187/252	1	9.6	67.7	3.9	13.5	15.9	25	4.2	13.8	16.2	25
	F.L.	460-3-60*	432/504	1	4.5	38.1	1.2	5.7	6.8	15	3.4	7.9	9.0	15
SR036	G.J.	208/230-1-60	187/252	1	14.4	86.0	6.0	20.4	24.0	35	5.9	20.3	23.9	35
	E.D.	265-1-60	249/291	1	10.2	55.0	5.2	15.4	18.0	25	4.8	15.0	17.6	25
	H.K.	208/230-3-60	187/252	1	9.0	70.0	6.0	15.0	17.3	25	5.9	14.9	17.2	25
	F.L.	460-3-60*	432/504	1	4.1	39.0	1.7	5.8	6.8	15	4.8	8.9	9.9	15
SR042	G.J.	208/230-1-60	187/252	1	17.3	123.0	6.0	23.3	27.6	40	5.9	23.2	27.5	40
	H.K.	208/230-3-60	187/252	1	12.8	102.8	6.0	18.8	22.0	30	5.9	18.7	21.9	30
	F.L.	460-3-60*	432/504	1	5.8	48.5	1.7	7.5	9.0	15	4.8	10.6	12.1	15
SR048	G.J.	208/230-1-60	187/252	1	22.4	126.0	6.0	28.4	34.0	50	5.9	28.3	33.9	50
	H.K.	208/230-3-60	187/252	1	12.8	120.4	6.0	18.8	22.0	30	5.9	18.7	21.9	30
	F.L.	460-3-60*	432/504	1	6.0	49.4	1.7	7.7	9.2	15	4.8	10.8	12.3	15
SR060	G.J.	208/230-1-60	187/252	1	23.7	157.0	7.4	31.1	37.0	60	7.5	31.2	37.1	60
	H.K.	208/230-3-60	187/252	1	16.0	156.4	7.4	23.4	27.4	40	7.5	23.5	27.5	40
	F.L.	460-3-60*	432/504	1	7.1	69.0	2.3	9.4	11.2	15	6.2	13.3	15.1	20

***Neutral connection required! All F and L voltage (460VAC) units with a CV EC motor require a four-wire power supply with neutral. The CV EC motor is rated 265VAC and is wired between one hot leg and neutral.**

Electrical Data

EC Blower Motor with Internal Secondary Pump

Models:
SR
006-060

SR Commercial Electrical Table W/ ISP								CT EC				CV EC*			
Model	VOLTAGE CODE	VOLTAGE	VOLTAGE MIN/MAX	COMPRESSOR			PUMP FLA	FAN MOTOR FLA	TOTAL UNIT FLA	MIN CIRCUIT AMP	FUSE/HACR AMP	FAN MOTOR FLA	TOTAL UNIT FLA	MIN CIRCUIT AMP	FUSE/HACR AMP
				QTY	RLA	LRA									
SR006	G.J.	208/230-1-60	187/252	1	3.7	17.7	0.4	2.3	6.4	7.3	15	1.5	5.6	6.5	15
	E.D.	265-1-60	249/291	1	2.6	10.5	0.7	2.3	5.6	6.3	15	1.4	4.7	5.4	15
SR009	G.J.	208/230-1-60	187/252	1	5.0	22.2	0.4	2.3	7.7	9.0	15	1.5	6.9	8.2	15
	E.D.	265-1-60	249/291	1	3.6	13.5	0.7	2.3	6.6	7.5	15	1.4	5.7	6.6	15
SR012	G.J.	208/230-1-60	187/252	1	5.6	32.5	0.8	2.3	8.7	10.1	15	2.6	9.0	10.4	15
	E.D.	265-1-60	249/291	1	4.2	23.0	0.7	2.3	7.2	8.3	15	2.5	7.4	8.5	15
SR015	G.J.	208/230-1-60	187/252	1	6.6	31.0	0.8	2.6	10.0	11.7	15	2.6	10.0	11.7	15
	E.D.	265-1-60	249/291	1	5.0	27.0	0.7	1.9	7.6	8.9	15	2.4	8.1	9.4	15
SR018	G.J.	208/230-1-60	187/252	1	7.0	35.0	0.8	2.6	10.4	12.2	15	2.6	10.4	12.2	15
	E.D.	265-1-60	249/291	1	6.5	40.0	0.7	1.9	9.1	10.7	15	2.1	9.3	10.9	15
SR024	G.J.	208/230-1-60	187/252	1	11.4	64.4	0.8	3.9	16.1	19.0	30	4.2	16.4	19.3	30
	E.D.	265-1-60	249/291	1	10.3	60.5	0.7	3.7	14.7	17.3	25	3.4	14.4	17.0	25
	H.K.	208/230-3-60	187/252	1	7.7	59.9	0.8	3.9	12.4	14.3	20	4.2	12.7	14.6	20
	F.L.	460-3-60*	432/504	1	3.8	32.4	0.7	1.2	5.7	6.7	15	3.4	7.9	8.9	15
SR030	G.J.	208/230-1-60	187/252	1	12.7	75.6	0.8	3.9	17.4	20.6	30	4.2	17.7	20.9	30
	E.D.	265-1-60	249/291	1	11.5	84.0	0.7	3.7	15.9	18.8	30	3.4	15.6	18.5	25
	H.K.	208/230-3-60	187/252	1	9.6	67.7	0.8	3.9	14.3	16.7	25	4.2	14.6	17.0	25
	F.L.	460-3-60*	432/504	1	4.5	38.1	0.7	1.2	6.4	7.5	15	3.4	8.6	9.7	15
SR036	G.J.	208/230-1-60	187/252	1	14.4	86.0	0.8	6.0	21.2	24.8	35	5.9	21.1	24.7	35
	E.D.	265-1-60	249/291	1	15.4	55.0	0.7	5.2	16.1	18.7	25	4.8	15.7	18.3	25
	H.K.	208/230-3-60	187/252	1	9.0	70.0	0.8	6.0	15.8	18.1	25	5.9	15.7	18.0	25
	F.L.	460-3-60*	432/504	1	4.1	39.0	0.7	1.7	6.5	7.5	15	4.8	9.6	10.6	15
SR042	G.J.	208/230-1-60	187/252	1	17.3	123.0	0.8	6.0	24.1	28.4	45	5.9	24.0	28.3	45
	H.K.	208/230-3-60	187/252	1	12.8	102.8	0.8	6.0	19.6	22.8	35	5.9	19.5	22.7	35
	F.L.	460-3-60*	432/504	1	5.8	48.5	0.7	1.7	8.2	9.7	15	4.8	11.3	12.8	15
SR048	G.J.	208/230-1-60	187/252	1	22.4	126.0	1.1	6.0	29.5	35.1	50	5.9	29.4	35.0	50
	H.K.	208/230-3-60	187/252	1	12.8	120.4	1.1	6.0	19.9	23.1	35	5.9	19.8	23.0	35
	F.L.	460-3-60*	432/504	1	6.0	49.4	1.3	1.7	9.0	10.5	15	4.8	12.1	13.6	15
SR060	G.J.	208/230-1-60	187/252	1	23.7	157.0	1.1	7.4	32.2	38.1	60	7.5	32.3	38.2	60
	H.K.	208/230-3-60	187/252	1	16.0	156.4	1.1	7.4	24.5	28.5	40	7.5	24.6	28.6	40
	F.L.	460-3-60*	432/504	1	7.1	69.0	1.3	2.3	10.7	12.5	15	6.2	14.6	16.4	20

***Neutral connection required! All F and L voltage (460VAC) units with a CV EC motor or an Internal Secondary Pump require a four-wire power supply with neutral. The CV EC motor and ISP are rated 265VAC and is wired between one hot leg and neutral.**

Electrical Data EC Blower Motor Hybrid or WSE Unit

Models:
SR
006-060

Model	SR Electrical Table						CT EC				CV EC*			
	VOLTAGE CODE	VOLTAGE	VOLTAGE MIN/MAX	COMPRESSOR			FAN MOTOR FLA	TOTAL UNIT FLA	MIN CIRCUIT AMP	FUSE/HACR AMP	FAN MOTOR FLA	TOTAL UNIT FLA	MIN CIRCUIT AMP	FUSE/HACR AMP
				QTY	RLA	LRA								
SR024	G.J	208/230-1-60	187/252	1	11.4	64.4	3.9	15.3	18.2	25	4.2	15.6	18.5	25
	E.D.	265-1-60	249/291	1	10.3	60.5	3.7	14.0	16.6	25	3.4	13.7	16.3	25
	H.K.	208/230-3-60	187/252	1	7.7	59.9	3.9	11.6	13.5	20	4.2	11.9	13.8	20
	F.L.	460-3-60*	432/504	1	3.8	32.4	1.2	5.0	6.0	15	3.4	7.2	8.2	15
SR030	G.J	208/230-1-60	187/252	1	12.7	75.6	3.9	16.6	19.8	30	4.2	16.9	20.1	30
	E.D.	265-1-60	249/291	1	11.5	84.0	3.7	15.2	18.1	25	3.4	14.9	17.8	25
	H.K.	208/230-3-60	187/252	1	9.6	67.7	3.9	13.5	15.9	25	4.2	13.8	16.2	25
	F.L.	460-3-60*	432/504	1	4.5	38.1	1.2	5.7	6.8	15	3.4	7.9	9.0	15
SR036	G.J	208/230-1-60	187/252	1	14.4	86.0	6.0	20.4	24.0	35	5.9	20.3	23.9	35
	E.D.	265-1-60	249/291	1	10.2	55.0	5.2	15.4	18.0	25	4.8	15.0	17.6	25
	H.K.	208/230-3-60	187/252	1	9.0	70.0	6.0	15.0	17.3	25	5.9	14.9	17.2	25
	F.L.	460-3-60*	432/504	1	4.1	39.0	1.7	5.8	6.8	15	4.8	8.9	9.9	15
SR042	G.J.	208/230-1-60	187/252	1	17.3	123.0	6.0	23.3	27.6	40	5.9	23.2	27.5	40
	H.K.	208/230-3-60	187/252	1	12.8	102.8	6.0	18.8	22.0	30	5.9	18.7	21.9	30
	F.L.	460-3-60*	432/504	1	5.8	48.5	1.7	7.5	9.0	15	4.8	10.6	12.1	15
SR048	G.J.	208/230-1-60	187/252	1	22.4	126.0	6.0	28.4	34.0	50	5.9	28.3	33.9	50
	H.K.	208/230-3-60	187/252	1	12.8	120.4	6.0	18.8	22.0	30	5.9	18.7	21.9	30
	F.L.	460-3-60*	432/504	1	6.0	49.4	1.7	7.7	9.2	15	4.8	10.8	12.3	15
SR060	G.J.	208/230-1-60	187/252	1	23.7	157.0	7.4	31.1	37.0	60	7.5	31.2	37.1	60
	H.K.	208/230-3-60	187/252	1	16.0	156.4	7.4	23.4	27.4	40	7.5	23.5	27.5	40
	F.L.	460-3-60*	432/504	1	7.1	69.0	2.3	9.4	11.2	15	6.2	13.3	15.1	20

***Neutral connection required! All F and L voltage (460VAC) units with a CV EC motor require a four-wire power supply with neutral. The CV EC motor is rated 265VAC and is wired between one hot leg and neutral.**

Electrical Data EC Blower Motor with Internal Secondary Pump Hybrid or WSE Unit

Models:
SR
006-060

SR Commercial Electrical Table W/ ISP								CT EC				CV EC*			
Model	VOLTAGE CODE	VOLTAGE	VOLTAGE MIN/MAX	COMPRESSOR			PUMP FLA	FAN MOTOR FLA	TOTAL UNIT FLA	MIN CIRCUIT AMP	FUSE/HACR AMP	FAN MOTOR FLA	TOTAL UNIT FLA	MIN CIRCUIT AMP	FUSE/HACR AMP
				QTY	RLA	LRA									
SR030	G.J	208/230-1-60	187/252	1	12.7	75.6	0.8	3.9	17.4	20.6	30	4.2	17.7	20.9	30
	E.D.	265-1-60	249/291	1	11.5	84.0	0.7	3.7	15.9	18.8	30	3.4	15.6	18.5	25
	H.K.	208/230-3-60	187/252	1	9.6	67.7	0.8	3.9	14.3	16.7	25	4.2	14.6	17.0	25
	F.L.	460-3-60*	432/504	1	4.5	38.1	0.7	1.2	6.4	7.5	15	3.4	8.6	9.7	15
SR036	G.J	208/230-1-60	187/252	1	14.4	86.0	0.8	6.0	21.2	24.8	35	5.9	21.1	24.7	35
	E.D.	265-1-60	249/291	1	15.4	55.0	0.7	5.2	16.1	18.7	25	4.8	15.7	18.3	25
	H.K.	208/230-3-60	187/252	1	9.0	70.0	0.8	6.0	15.8	18.1	25	5.9	15.7	18.0	25
	F.L.	460-3-60*	432/504	1	4.1	39.0	0.7	1.7	6.5	7.5	15	4.8	9.6	10.6	15
SR042	G.J	208/230-1-60	187/252	1	17.3	123.0	0.8	6.0	24.1	28.4	45	5.9	24.0	28.3	45
	H.K.	208/230-3-60	187/252	1	12.8	102.8	0.8	6.0	19.6	22.8	35	5.9	19.5	22.7	35
	F.L.	460-3-60*	432/504	1	5.8	48.5	0.7	1.7	8.2	9.7	15	4.8	11.3	12.8	15
SR048	G.J	208/230-1-60	187/252	1	22.4	126.0	1.1	6.0	29.5	35.1	50	5.9	29.4	35.0	50
	H.K.	208/230-3-60	187/252	1	12.8	120.4	1.1	6.0	19.9	23.1	35	5.9	19.8	23.0	35
	F.L.	460-3-60*	432/504	1	6.0	49.4	1.3	1.7	9.0	10.5	15	4.8	12.1	13.6	15
SR060	G.J	208/230-1-60	187/252	1	23.7	157.0	1.1	7.4	32.2	38.1	60	7.5	32.3	38.2	60
	H.K.	208/230-3-60	187/252	1	16.0	156.4	1.1	7.4	24.5	28.5	40	7.5	24.6	28.6	40
	F.L.	460-3-60*	432/504	1	7.1	69.0	1.3	2.3	10.7	12.5	15	6.2	14.6	16.4	20

***Neutral connection required! All F and L voltage (460VAC) units with a CV EC motor or an Internal Secondary Pump require a four-wire power supply with neutral. The CV EC motor and ISP are rated 265VAC and is wired between one hot leg and neutral.**

ClimateMaster works continually to improve its products. As a result, the design and specifications of each product at the time of order may be changed without notice and may not be as described herein. Please contact ClimateMaster's Customer Service Department at 800-299-9747 for specific information on the current design and specifications. Statements and other information contained herein are not express warranties and do not form the basis of any bargain between the parties, but are merely ClimateMaster's opinion or commendation of its products. The latest version of this document is available at www.climatemaster.com. Engineered and assembled in the USA. © ClimateMaster, Inc. All Rights Reserved 2024

Electrical Data PSC Blower Motor with WSE

Models:
SR
006-060

Model	VOLTAGE CODE	VOLTAGE	VOLTAGE MIN/MAX	COMPRESSOR			FAN MOTOR FLA	TOTAL UNIT FLA	MIN CIRCUIT AMP	FUSE/HACR AMP
				QTY	RLA	LRA				
SR036	G.J	208/230-1-60	187/252	1	14.4	86.0	2.6	17.0	20.6	35
	E.D.	265-1-60	249/291	1	10.2	55.0	2.0	12.2	14.8	25
	H.K.	208/230-3-60	187/252	1	9.0	70.0	2.6	11.6	13.9	20
	F.L.	460-3-60	432/504	1	4.1	39.0	1.2	5.3	6.3	15
SR042	G.J	208/230-1-60	187/252	1	17.3	123.0	2.7	20.0	24.3	40
	H.K.	208/230-3-60	187/252	1	12.8	102.8	2.7	15.5	18.7	30
	F.L.	460-3-60	432/504	1	5.8	48.5	1.6	7.4	8.9	15
	N.M.	575-3-60	540/630	1	5.1	41.0	1.4	6.5	7.8	15
SR048	G.J	208/230-1-60	187/252	1	22.4	126.0	3.3	25.7	31.3	50
	H.K.	208/230-3-60	187/252	1	12.8	120.4	3.3	16.1	19.3	30
	F.L.	460-3-60	432/504	1	6.0	49.4	1.7	7.7	9.2	15
	N.M.	575-3-60	540/630	1	5.8	41.0	1.4	7.2	8.7	15
SR060	G.J	208/230-1-60	187/252	1	23.7	157.0	4.8	28.5	34.4	50
	H.K.	208/230-3-60	187/252	1	16.0	156.4	4.8	20.8	24.8	40
	F.L.	460-3-60	432/504	1	7.1	69.0	2.4	9.5	11.3	15
	N.M.	575-3-60	540/630	1	6.4	48.0	1.8	8.2	9.8	15

ClimateMaster works continually to improve its products. As a result, the design and specifications of each product at the time of order may be changed without notice and may not be as described herein. Please contact ClimateMaster's Customer Service Department at 800-299-9747 for specific information on the current design and specifications. Statements and other information contained herein are not express warranties and do not form the basis of any bargain between the parties, but are merely ClimateMaster's opinion or commendation of its products. The latest version of this document is available at www.climatemaster.com. Engineered and assembled in the USA. © ClimateMaster, Inc. All Rights Reserved 2024

HOT GAS REHEAT OPTION

The Hot Gas Reheat (HGRH) option provides effective dehumidification and reheat without the need for additional heating sources or complex controls. Hot Gas Reheat utilizes hot refrigerant gas generated during the cooling mode, which is redirected through a reheat coil downstream of the evaporator coil. This process allows the system to provide reheat while simultaneously removing moisture from the air, ensuring consistent temperature and humidity control.

HOT GAS REHEAT BENEFITS

Hot Gas Reheat is a reliable solution for maintaining comfort in dehumidification mode. When activated, the system delivers 100% reheat capacity, making this option beneficial during periods when the cooling load is low, but humidity control is still necessary.

The system works by diverting hot refrigerant gas from the compressor discharge through a secondary coil which reheats the supply air to a neutral temperature before it enters the conditioned space. This simple design ensures ease of operation and maintenance.

HOT GAS REHEAT APPLICATIONS

Hot Gas Reheat is ideal for a variety of applications where maintaining humidity levels is critical, including:

- Classrooms
- Condominiums
- Apartments
- Computer rooms
- Spaces with high latent loads like auditoriums, theaters, convention centers, etc.
- Any space requiring dehumidification with occasional reheat needs

NOTE: Hot gas reheat is not for use in high-fraction outdoor air applications or in applications with corrosive atmospheres, such as pool rooms.

With the Hot Gas Reheat option, return air from the space is cooled by the air-to-refrigerant (evaporator) coil, and then reheated by the hot gas reheat coil to dehumidify the air, while maintaining the desired space temperature.

Table 3: Leaving Dry Bulb Temperature vs Entering Water Temperature

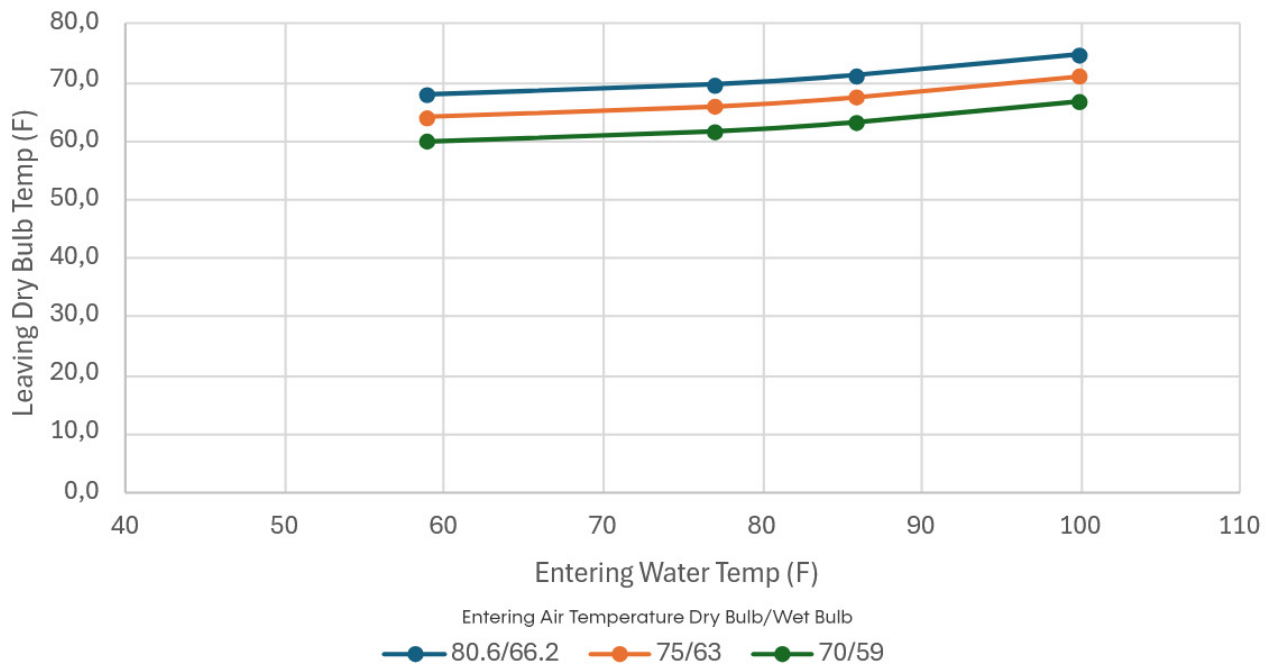

ClimateMaster works continually to improve its products. As a result, the design and specifications of each product at the time of order may be changed without notice and may not be as described herein. Please contact ClimateMaster's Customer Service Department at 800-299-9747 for specific information on the current design and specifications. Statements and other information contained herein are not express warranties and do not form the basis of any bargain between the parties, but are merely ClimateMaster's opinion or commendation of its products. The latest version of this document is available at www.climatemaster.com. Engineered and assembled in the USA. © ClimateMaster, Inc. All Rights Reserved 2024

The moisture removal capability of the heat pump is determined by the unit's latent capacity rating. Latent Capacity equals Total Capacity minus Sensible Capacity. Using unit performance data within this product catalog, use your maximum entering water temperature (EWT) and flow rate to select TC and SC. For example, at 80°F (26.7°C) EWT and 6.0 GPM, the moisture removal capability (latent capacity) of a SR036 is 8.4 Mbtuh (2.4 kW) as shown below.

Dividing the latent capacity by 1,069 BTU/LB of water vapor at 80°F DB and 67°F WB (26.7°C DB and 19.4°C WB) moist air enthalpy, converts the amount of moisture removal to pounds per hour (multiply pounds per hour by 0.4536 to obtain kg/hr). Calculations are shown below.

Most ClimateMaster heat pumps have a sensible-to-total heat ratio (SHR) of 0.72 to 0.82. Therefore, approximately 25% of the cooling capacity is dedicated to latent cooling capacity (moisture removal). When selecting a unit with Hot Gas Reheat, the space sensible and latent loads should be calculated. If the unit will be used for space cooling, a unit with at least enough capacity to satisfy the building sensible load should be selected. If the latent cooling load is not satisfied by the selection, a larger unit with enough latent capacity will be required. If the unit will be used for dehumidification purposes only, the latent capacity is the only consideration necessary. In this case, sensible load is immaterial.

Table 4: Example SR036 EC Performance

EWT °F	WPD			COOLING - EAT 80/67°F					WPD			Heating - EAT 70°F			
	FLOW GPM	PSI	FT	TC	SC	kW	HR	EER	FLOW GPM	PSI	FT	HC	kW	COP	HE
70	3.0	0.4	0.9	34.3	26.3	2.5	42.7	13.9	4.5	0.8	2.0	40.1	2.7	4.3	30.7
	6.0	1.2	2.9	36.6	27.3	2.1	43.7	17.6	6.0	1.2	2.9	44.2	2.9	4.5	34.5
	9.0	2.4	5.6	37.3	27.5	2.0	44.0	19.0	9.0	2.4	5.6	45.8	2.9	4.6	35.9
80	3.0	0.4	0.9	32.4	25.4	2.8	41.9	11.7	4.5	0.8	1.9	43.7	2.8	4.5	34.0
	6.0	1.2	2.8	35.0	26.6	2.4	43.0	14.9	6.0	1.2	2.8	48.2	3.0	4.7	38.0
	9.0	2.4	5.5	35.8	27.0	2.2	43.4	16.1	9.0	2.4	5.5	49.9	3.0	4.8	39.6
90	3.0	0.4	0.9	30.6	24.5	3.1	41.0	9.9	4.5	0.8	1.9	47.3	2.9	4.7	37.2
	6.0	1.2	2.8	33.2	25.8	2.6	42.2	12.6	6.0	1.2	2.8	52.0	3.1	4.9	41.5
	9.0	2.3	5.4	34.1	26.2	2.5	42.6	13.6	9.0	2.3	5.4	53.8	3.2	5.0	43.0

$$LC = TC - SC = 35 - 26.6 = 8.4 \text{ Mbtuh}$$

$$8,400 \text{ Btuh} \div 1,069 = 7.9 \text{ lbs/hr}$$

Dividing the latent capacity by 1,069 BTU/lb. of water vapor at 80°F DB and 67°F WB (26.7°C DB and 19.4°C WB) moist-air enthalpy, converts the amount of moisture removal to pounds per hour (multiply pounds per hour by 0.4536 to obtain kg/hr).

Hot Gas Reheat Sequence of Operations

Models:
SR
006-060

A heat pump equipped with HGRH can operate in three modes; cooling, cooling with reheat (dehumidification), and heating. The cooling/heating modes are like any other ClimateMaster WSHP. The reversing valve (“O” signal) is energized in cooling, along with the compressor contactor(s) and blower relay. In the heating mode the reversing valve is de-energized. Almost any thermostat will activate the heat pump in heating or cooling modes. The DXM2.5 accepts either heat-pump (Y,O) thermostats or non-heat-pump (Y,W) thermostats.

Reheat mode requires either a separate humidistat/dehumidistat or a thermostat that has an integrated dehumidification function for activation. The control board is configured to work with either a humidistat or dehumidistat input to terminal “H” (DIP switch settings for the DXM2.5 are shown below in table 5). Upon receiving an “H” input, the DXM2.5 activates the cooling mode and engages reheat. Table 6 shows the relationship between thermostat input signals and unit operation.

There are four operational inputs for single-stage units:

- Fan Only
- 1st Stage Cooling
- 1st Stage Heating
- Reheat Mode

Table 5: Humidistat/Dehumidistat Logic and DXM2.5 (2.1, 2.2, 2.3) DIP settings

Sensor	2.1	2.2	2.3	Logic	Reheat (ON)-H	Reheat (OFF)-H
Humidistat	OFF	OFF	OFF	Reverse	0 VAC	24 VAC
Dehumidistat	OFF	ON	OFF	Standard	24 VAC	0 VAC

Table 6: Hot Gas Reheat Operating Modes

Mode	Input				Output			
	O	G	Y1	H	RV	Fan	H/C	Reheat
No Demand	ON/OFF	OFF	OFF	OFF	ON/OFF	OFF	OFF	OFF
Fan Only	ON/OFF	ON	OFF	OFF	ON/OFF	ON	OFF	OFF
Cooling	ON	ON	ON	OFF	ON	ON	ON	OFF
Cooling and Dehumidistat ¹	ON	ON	ON	ON	ON	ON	ON	ON
Dehumidistat Only	ON/OFF	OFF	OFF	ON	ON	ON	ON	ON
Heating	OFF	ON	ON	OFF	OFF	ON	ON	OFF
Heating and Dehumidistat ²	OFF	ON	ON	ON	OFF	ON	ON	OFF

1. Cooling input takes priority over dehumidify input.
2. CXM2/DXM2.5 is programmed to ignore the H demand when the unit is in heating mode.

General Operation: Hot gas reheat controls to a configurable leaving air temperature setpoint (68-72°F [20-22°C], default: 70°F [21.1°C]). A hysteresis prevents the hot gas reheat valve from toggling when the leaving air temperature is near the leaving air temperature setpoint. If the leaving air temperature is greater than 0.5°F (0.3°C) above the leaving air temperature setpoint, the hot gas reheat output will be disabled. Any time the hot gas reheat output is toggled to off, there will be a minimum off time enforced. If the leaving air temperature drops 2°F (1.1°C) below the leaving air temperature setpoint, the hot gas reheat output will be re-enabled and a specified minimum on time will be enforced.

AWC Thermostat Operation: If there is a smart wall sensor present, such as the AWC Thermostat, reheat operation will be controlled by dehumidification demand and overcooling limitations.

Fan Only: A (G) call from the thermostat to the (G) terminal of the control board will bring the unit on in fan only mode.

Cooling: A simultaneous call from (G), (Y1), and (O) to the (G), (Y1), (O/W2) terminals of the control board will bring the unit on in Cooling, and the unit will run until the call is removed or satisfied, shutting down the unit. If there is only cooling demand, there will be no hot gas reheat operation.

Heating: A simultaneous call from (G) and (Y1) to the (G) and (Y1) terminals of the control board bring the unit on in Heating and run in heating until the call is removed or setpoint satisfied, shutting down the unit.

ClimateMaster works continually to improve its products. As a result, the design and specifications of each product at the time of order may be changed without notice and may not be as described herein. Please contact ClimateMaster's Customer Service Department at 800-299-9747 for specific information on the current design and specifications. Statements and other information contained herein are not express warranties and do not form the basis of any bargain between the parties, but are merely ClimateMaster's opinion or commendation of its products. The latest version of this document is available at www.climatemaster.com. Engineered and assembled in the USA. © ClimateMaster, Inc. All Rights Reserved 2024

Dehumidification Only Operation: If there is demand for dehumidification, the control will operate the hot gas reheat output until the dehumidification demand is satisfied or the overcooling setpoint (0-2°F [0-1.1°C] from Cooling Setpoint) is exceeded. The control will operate the blower at a reduced cooling airflow (80-82% of rated). When the dehumidification call is removed, a bleed valve engages, pulling refrigerant and oil from the reheat circuit and back into the base unit refrigerant circuit.

Cooling with Dehumidification Operation: If there is demand for both cooling and dehumidification, the control will operate the hot gas reheat output until the dehumidification demand is satisfied or the overcooling setpoint (0-2°F [0-1.1°C] from Cooling Setpoint) is exceeded. The control will operate the blower at a reduced cooling airflow (80-82%). If dehumidification demand is satisfied before the cooling demand, the cooling airflow will return to normal until the cooling demand is satisfied. If the cooling demand is satisfied before the dehumidification demand, the hot gas reheat operation will continue until the above criteria is met.

HOT GAS REHEAT FEATURES

The HGRH option consists of the following components:

- Choose one of the following options:
 - CXM2 with CT EC blower assembly (includes an external/off-board relay that allows the reduced fan speed)
 - DXM2.5 with CT EC or CV EC blower assembly
- Hot Gas Reheat Valve
- Supply Air Sensor
- EC Motor
- Reheat Coil

The control board operates on 24VAC power supply and automatically opens or closes the reheat valve based upon the supply air temperature. The supply air sensor detects supply air temperature at the blower inlet providing the input signal necessary for the control board to drive the reheat valve open or closed during the reheat mode of operation.

The amount of reheating is dependent on the setpoint and how far from setpoint the supply air temperature is. The factory setpoint is 70°F (21.1°C), generally considered neutral air.

ClimateMaster works continually to improve its products. As a result, the design and specifications of each product at the time of order may be changed without notice and may not be as described herein. Please contact ClimateMaster's Customer Service Department at 800-299-9747 for specific information on the current design and specifications. Statements and other information contained herein are not express warranties and do not form the basis of any bargain between the parties, but are merely ClimateMaster's opinion or commendation of its products. The latest version of this document is available at www.climatemaster.com. Engineered and assembled in the USA. © ClimateMaster, Inc. All Rights Reserved 2024

REFRIGERATION CHARGE AND OIL RETURN MITIGATION MODE

The system includes an advanced Refrigerant Charge and Oil Return Mitigation Mode designed to ensure optimal performance and reliability of the reheat circuit under various operating conditions. This feature seamlessly transitions refrigerant between the reheat circuit and the base unit refrigerant circuit to maintain system balance and compressor lubrication.

Operational Scenarios

- **Scenario 1 – Transition from Dehumidification with No Cooling Call:** When the system exits dehumidification mode and there is no active cooling call, a bleed valve engages to transfer refrigerant from the reheat circuit back into the base unit refrigerant circuit. This ensures proper refrigerant distribution and oil return. The bleed cycle operates for a specified period of time to complete this process.
- **Scenario 2 – Transition from Dehumidification with an Active Cooling Call:** If the system exits dehumidification mode but a cooling call remains active, the system enters the Refrigerant Charge and Oil Return Mitigation Mode. The bleed valve engages to transfer refrigerant from the reheat circuit to the base unit refrigerant circuit. This process operates for a specified period of time to ensure proper refrigerant and oil balance while maintaining uninterrupted cooling operation.

Key Advantages

- **System Reliability:** Prevents refrigerant pooling in the reheat circuit and ensures proper oil return to the compressor, minimizing wear and extending system lifespan.
- **Optimized Performance:** Maintains refrigerant balance between circuits for efficient operation in dehumidification and cooling modes.
- **Enhanced Flexibility:** Designed to handle diverse operating conditions, including transitions between dehumidification and cooling, to meet varying humidity and temperature requirements.

GENERAL

Furnish and install ClimateMaster Tranquility® SR water-source heat pumps, as indicated on the plans. Equipment shall be completely assembled, piped and internally wired. Capacities and characteristics as listed in the schedule and the specifications that follow.

Units shall be supplied completely factory built capable of operating over an entering water temperature range from 20° to 120°F (-6.7° to 43.3°C) as standard. Equivalent units from other manufacturers may be proposed provided approval to bid is given 10 days prior to bid closing. All equipment listed in this section must be rated and certified in accordance with Air-Conditioning, Heating and Refrigeration Institute / International Standards Organization (AHRI / ISO 13256-1). All equipment must be tested, investigated, and determined to comply with the requirements of the standards for Heating and Cooling Equipment UL 60335-2-40 4th Edition, UL 60335-1 6th Edition for the United States and Can/CSA C22.2 No. 60335-2-40:22, CAN/CSA C22.2 No 60335-1:16 for Canada, by Intertek Testing Laboratories (ETL). The units shall have AHRI / ISO and ETL-US-C labels.

All units shall pass a factory acceptance test. The quality control system shall automatically perform factory acceptance test via computer. A detailed report card from the factory acceptance test shall be shipped with each unit. **Note: If a unit fails the factory acceptance test, it shall not be allowed to ship. Unit serial number shall be recorded by factory acceptance test and furnished on report card for ease of unit warranty status.**

BASIC CONSTRUCTION

Horizontal units shall have one of the following air flow arrangements: Left Inlet/Straight (Right) Discharge; Right Inlet/Straight (Left) Discharge; Left Inlet/Back Discharge; or Right Inlet/Back Discharge as shown on the plans. Units must have the ability to be field convertible from straight to back or back to straight discharge with no additional parts or unit structure modification. Horizontal units will have factory installed hanger brackets with rubber isolation grommets packaged separately.

Vertical Units shall have one of the following air flow arrangements: Left Return/Top Discharge, Right Return/Top Discharge, as shown on the plans.

If units with these arrangements are not used, the contractor is responsible for any extra costs incurred by other trades. All units (horizontal and vertical) must have a minimum of three access panels for serviceability of compressor compartment. **Units having only one or two access panels to compressor/heat exchangers/expansion device/refrigerant piping shall not be acceptable.**

Compressor section interior surfaces shall be lined with ½-inch (12.7 mm) thick, 1½ lb/ft³ (24 kg/m³) acoustic type glass fiber insulation. Air handling section interior surfaces shall be lined with ½-inch (12.7 mm) thick, 1½ lb/ft³ (24 kg/m³) **foil-faced**, glass-fiber insulation for ease of cleaning. Insulation placement shall be designed in a manner that will eliminate any exposed edges to prevent the introduction of glass fibers into the air stream. **Units without foil-faced insulation in the air handling section will not be accepted.**

The heat pumps shall be fabricated from heavy gauge galvanized steel.

Standard insulation must meet NFPA Fire Hazard Classification requirements 25/50 per ASTM E84, UL 723, CAN/ULC S102-M88 and NFPA 90A requirements; air erosion and mold growth limits of UL-181; stringent fungal resistance test per ASTM-C1071 and ASTM G21; and shall meet zero level bacteria growth per ASTM G22. **Unit insulation must meet these stringent requirements or unit(s) will not be accepted.**

All horizontal units to have factory installed 1-inch (25.4 mm) discharge air duct collars, 1-inch (25.4 mm) filter rails with 1-inch (25.4 mm) filters factory installed, and factory installed unit-mounting brackets. Vertical units to have field installed discharge air duct collar, shipped loose and 1-inch (25.4 mm) filter rails with 1-inch (25.4 mm) filters factory installed. **If units with these factory-installed provisions are not used, the contractor is responsible for any extra costs to field install these provisions, and/or the extra costs for their subcontractor to install these provisions.**

All units must have an insulated panel separating the fan compartment from the compressor compartment. Units with the compressor in the air stream are not acceptable. Units shall have factory installed 1-inch (25.4 mm) wide filter rails for filter removal from either side. Units shall have a 1-inch (25.4 mm) thick throwaway type glass fiber filter. **The contractor shall purchase one spare set of filters and replace factory shipped filters on completion of startup.** Filters shall be standard sizes. **If units utilize non-standard filter sizes then the contractor shall provide 12 spare filters for each unit.**

Cabinets shall have separate holes and knockouts for entrance of line voltage and low voltage control wiring. All factory-installed wiring passing through factory knockouts and openings shall be protected from sheet metal edges at openings by plastic ferrules. Supply and return water connections shall be copper FPT fittings. All water connections and electrical knockouts must be in the compressor compartment corner post as to not interfere with the serviceability of unit. **Contractors shall be responsible for any extra costs involved in the installation of units that do not have this feature.** Contractors must ensure that units can be easily removed for servicing and coordinate locations of electrical conduit and lights with the electrical contractor.

Option: The unit will be supplied with optional field or factory installed 2-inch air filter rails (typically used for free return installation) or 1-inch or 2-inch air filter frames with filter access door and return air duct flanges (typically used for ducted return installation). A corresponding 1-inch or 2-inch throwaway type glass filter will ship with the factory installed filter rails or frame.

Option: UltraQuiet package shall consist of additional sound insulation applied to the base pan, removable panels, and blower housing.

Option: The unit shall be supplied with extended range insulation option, which adds closed cell foam insulation to internal water lines, and provides insulation on suction side refrigeration tubing including refrigerant-to-water heat exchanger.

BLOWER AND MOTOR ASSEMBLY

Blowers shall have inlet rings to allow removal of wheel and motor from one side without removing housing. Units shall have a direct-drive centrifugal fan. The fan motor shall be three-speed (two-speed for 575V), permanently lubricated, PSC type, with internal thermal overload protection. Units supplied without permanently lubricated motors must provide external oilers for easy service. The fan motor on small and medium size units (006-042) shall be isolated from the fan housing by a torsionally flexible motor mounting system with rubber type grommets to inhibit vibration induced high noise levels associated with "hard wire belly band" motor mounting. The fan motor on larger units (048 and 060) shall be isolated with flexible rubber type isolation grommets only. The fan and motor assembly must be capable of overcoming the external static pressures as shown on the schedule. Airflow/Static pressure rating of the unit shall be based on a wet coil and a clean filter in place. Ratings based on a dry coil, and/or no air filter, shall NOT be acceptable.

Option: Constant Torque (CT) EC motors (sizes 006 to 060): The CT EC fan motor maximizes efficiency over its static operating range and provides airflow adjustment with 4 or 5 speed taps. The fan motor shall be isolated from the housing by rubber grommets. The motor shall be permanently lubricated and have thermal overload protection.

Option: Constant Volume (CV) EC motors (sizes 006 to 060): EC variable speed ball bearing type motor. The EC fan motor shall provide a soft low noise fan start by ramping fan up to full selected speed over a 30 second period, and slowly ramp down fan at the end of each blower cycle, maintain constant CFM, maximize fan system efficiency over its static operating range, and provide airflow adjustment in 25 CFM increments. The fan motor shall be isolated from the housing by rubber grommets. The motor shall be permanently lubricated and have thermal overload protection. A special dehumidification mode shall be provided to allow lower airflows in cooling for better dehumidification.

The dehumidification mode may be constant or automatic (humidistat controlled). Constant CFM EC motors without controlled ramp up and ramp down features, with constant CFM speed taps, or with no microprocessor controller are not acceptable.

REFRIGERANT CIRCUIT

All units shall contain an R-454B sealed refrigerant circuit including a high efficiency scroll or rotary compressor designed for heat pump operation, a thermostatic expansion valve for refrigerant metering, an enhanced corrugated aluminum lanced fin and rifled copper tube refrigerant-to-air heat exchanger, reversing valve, coaxial (tube-in-tube) refrigerant-to-water heat exchanger, and safety controls including a high-pressure switch, low-pressure (loss-of-charge) switch, water coil low-temperature sensor, and air coil low-temperature sensor. Access fittings shall be factory installed on high- and low-pressure refrigerant lines to facilitate field service. Activation of any safety device shall prevent compressor operation via a microprocessor lockout circuit. The lockout circuit shall be reset at the thermostat or at the contractor-supplied disconnect switch. **Units that cannot be reset at the thermostat shall not be acceptable.**

Hermetic compressors shall be internally sprung. The compressor shall have a dual level vibration isolation system. The compressor will be mounted on specially engineered sound-tested EPDM vibration isolation grommets or springs to a heavy gauge compressor mounting plate, which is then isolated from the cabinet base with EPDM grommets for maximized vibration attenuation. Compressors shall have thermal overload protection. Compressors shall be located in an insulated compartment away from air stream to minimize sound transmission.

Refrigerant to air heat exchangers shall utilize enhanced corrugated lanced aluminum fins and rifled copper tube construction rated to withstand 625 PSIG (4,309 kPa) refrigerant working pressure. Refrigerant to water heat exchangers shall be of copper inner water tube and steel refrigerant outer tube design, rated to withstand 625 PSIG (4,309 kPa) working refrigerant pressure and 300 PSIG (3,445kPa) working water pressure. The refrigerant-to-water heat exchanger shall be "electro-coated" with a low cure cathodic epoxy material a minimum of 0.4 mils thick (0.4 – 1.5 mils range) on all surfaces. The black colored coating shall provide a minimum of 1,000 hours salt spray protection per ASTM B117-97 on all external steel and copper tubing. The material shall be formulated without the inclusion of any heavy metals and shall exhibit a pencil hardness of 2H (ASTM D3363-92A), crosshatch adhesion of 4B-5B (ASTM D3359-95), and impact resistance of 160 in-lbs (184 kg-cm) direct (ASTM D2794-93).

Units charged with 62 ounces or greater of R-454B shall be supplied with a Refrigerant Detection System (RDS) with sensors to be strategically placed within the cabinet. In the event of a refrigerant leak, the RDS disables compressor operation, and the unit blower runs to disperse any concentration of leaked refrigerant in compliance with UL 60335-2-40 safety standards for flammable refrigerants. **Units charged with 62 ounces or greater of R-454B that do not have an RDS shall not be acceptable.**

Option: The unit will be supplied with internally factory mounted two-way water valve for variable speed pumping requirements. A factory-mounted or field-installed high-pressure switch shall be installed in the water piping to disable compressor operation in the event water pressures build due to water freezing in the piping system.

- Option:** The unit will be supplied with internally factory mounted automatic water flow regulators.
- Option:** The unit will be supplied with internally mounted secondary pump for primary/secondary applications, including one-pipe systems.
- Option:** The unit will be supplied with cupro-nickel coaxial water to refrigerant heat exchanger.
- Option:** The Refrigerant Detection System (RDS) package shall consist of the RDS module and sensors to be strategically placed within the cabinet. In the event of a refrigerant leak, the RDS disables compressor operation and the unit blower runs to disperse any concentration of leaked refrigerant in compliance with UL 60335-2-40 safety standards for flammable refrigerants (Optional for sizes 006-048).
- Option:** The refrigerant-to-air heat exchanger shall be tin-plated.
- Option:** The unit shall be supplied with a hot water generator (desuperheater).
- Option:** The unit shall be supplied with an internally mounted water coil for hybrid heating operation.
- Option:** The unit shall be supplied with an internally mounted Waterside Economizer (WSE). The WSE will consist of a hydronic coil, modulating valve, and aquastat. The aquastat will be an adjustable type and factory set to 45°F (7.2°C). Units with the WSE require a heat-pump thermostat with two stages of cooling and stainless-steel drain pan.

- Option:** The unit shall be supplied with a hot gas reheat (HGRH) coil intended to provide air at or near neutral conditions to the conditioned space during dehumidification mode. The reheat system includes an advanced Refrigerant Charge and Oil Return Mitigation Mode designed to ensure optimal performance and reliability under various operating conditions. This feature seamlessly transitions refrigerant between the reheat circuit and the base unit refrigerant circuit to maintain system balance and compressor lubrication. Systems not providing Refrigerant Charge and Oil Return Mitigation functionality will not be accepted.

Refrigerant metering shall be accomplished by thermostatic expansion valve only. Expansion valves shall be dual port balanced type with external equalizer for optimum refrigerant metering. Units shall be designed and tested for operating ranges of entering water temperatures from 20° to 120°F (-6.7° to 48.9°C). The reversing valve shall be four-way solenoid activated refrigerant valve, which shall default to heating mode should the solenoid fail to function. If the reversing valve solenoid defaults to cooling mode, an additional low-temperature thermostat must be provided to prevent over-cooling an already cold room.

DRAIN PAN

The drain pan shall be constructed of a polymer material that inhibits corrosion. Drain outlet shall be connected from pan using provided polymer coupling and clamps that meet UL 2043 as required for discrete products by the IMC and UMC when located in a plenum. If galvanized-steel drain pan is used, it shall be fully insulated on all sides and must meet the stringent 1,000-hour salt spray test per ASTM B117. Drain outlet shall be located at pan as to allow unobstructed drainage of condensate. Drain outlet shall be connected from pan directly to a rubber coupling. **No hidden internal tubing extensions from pan outlet extending to unit casing (that can create drainage problems) will be accepted.** The unit as standard will be supplied with solid-state electronic condensate overflow protection. Mechanical float switches will NOT be accepted.

Option: The unit shall be supplied with stainless steel drain pan with ¾-inch MPT plumbing connection. The stainless-steel drain pan shall be fully insulated on all sides.

ELECTRICAL

A control box shall be located within the unit compressor compartment and shall contain a 50VA transformer, 24V activated, two or three-pole compressor contactor, terminal block for thermostat wiring and solid-state controller for complete unit operation. The control box on sizes 006 through 060 shall have a door to protect the internal components. The entire control box shall be capable of rotating out of the unit to allow access to the components behind the control box. Low voltage wires shall enter the box through a hole in the lower left side and high voltage wires shall enter the box through a hole in the upper left side. Reversing valve and blower motor wiring shall be routed through this electronic controller. Units shall be name-plated for use with time delay fuses or HACR circuit breakers. Unit controls shall be 24V and provide heating or cooling as required by the remote thermostat or sensor.

ENHANCED SOLID STATE CONTROL SYSTEM (CXM2)

Units shall have a solid-state control system. Units utilizing electro-mechanical control shall not be acceptable. The control system microprocessor board shall be specifically designed to protect against building electrical system noise contamination, EMI, and RFI interference. The control system shall interface with a heat pump type thermostat. The control system shall have the following features:

- a. Anti-short cycle time delay on compressor operation.
- b. Random start on power-up mode.
- c. Low-voltage protection.
- d. High-voltage protection.

- e. Unit shutdown on high- or low-refrigerant pressures.
- f. Unit shutdown on low water temperature.
- g. Condensate-overflow electronic protection.
- h. Option to reset unit at thermostat or disconnect.
- i. Automatic intelligent reset. Unit shall automatically reset the unit 5 minutes after trip if the fault has cleared. If a fault occurs three times sequentially without thermostat meeting temperature, then lockout requiring manual reset will occur.
- j. Ability to defeat time delays for servicing.
- k. The low-pressure switch shall not be monitored for the first 120 seconds after a compressor start command to prevent nuisance safety trips.
- l. 24V output to cycle a motorized water valve or other device with compressor contactor.
- m. Unit Performance Sentinel (UPS). The UPS warns when the heat pump is running inefficiently.
- n. Water coil low temperature sensing (selectable for water or anti-freeze).
- o. Air coil low-temperature sensing.
- p. Minimized reversing-valve operation (Unit control logic shall only switch the reversing valve when cooling is demanded for the first time. The reversing valve shall be held in this position until the first call for heating, ensuring quiet operation and increased valve life).
- q. Emergency-shutdown contacts.
- r. Entering- and leaving-water temperature sensing.
- s. Leaving-air temperature sensing.
- t. Compressor-discharge temperature sensing.

NOTE: Units not providing the eight safety protections of anti-short cycle, low voltage, high voltage, high refrigerant pressure, low pressure (loss of charge), air coil low temperature cut-out, water coil low temperature cut-out, and condensate overflow protections will not be accepted.

When CXM2 is connected to the AWC Thermostat or handheld service tool, the installer/service technician can; check DIP switch S2 settings; run operation modes manually; check all physical inputs from thermostat and refrigerant pressure switches status, (Y1, Y2, W, O, G, H, ESD, NSB, OR, HP switch, and LOC switch); current or at time of fault the following temperatures - water coil (LT1), air coil (LT2), compressor discharge, leaving air, leaving water, entering water and control voltage; record last five faults, list possible reasons, and clear faults. When the AWC Thermostat is used this same functionality can be viewed and adjusted remotely in the web portal or mobile app. **Systems not providing remote access, diagnosis, and adjustment functionality will not be accepted.**

Option: Enhanced Solid State Control System (DXM2.5)

This control system is a communicating controller.

Control shall have the above-mentioned features of the CXM2 control system along with the following expanded features:

- a. Removable thermostat connector.
- b. Night setback control.
- c. Random start on return from night setback.
- d. Override temperature control with 2-hour timer for room occupant to override setback temperature at the thermostat.
- e. Dry contact night setback output for digital night setback thermostats.
- f. Ability to work with heat pump or heat/cool (Y, W) type thermostats.
- g. Ability to work with heat pump thermostats using O or B reversing valve control.
- h. Boilerless system heat control at low loop water temperature.
- i. Ability to allow up to three units to be controlled by one thermostat.
- j. Relay to operate an external damper.
- k. Relay to start system pump.

- l. 75VA control transformer. Control transformer shall have load-side short circuit and overload protection via a built-in circuit breaker.
- m. Hot Gas Reheat (HGRH) shall be controlled by a humidistat connected to the controllers H terminal.

NOTE: Units not providing the eight safety protections of anti-short cycle, low voltage, high voltage, high refrigerant pressure, low pressure (loss of charge), air coil low temperature cut-out, water coil low temperature cut-out, and condensate overflow protection for both drain pans will not be accepted.

When DXM2.5 is connected to AWC Thermostat or handheld service tool, the installer/service technician can; check and set CFM; check DIP switch S1, S2, and S3 settings; run operation modes manually; check all physical inputs from thermostat and refrigerant pressure switches status, (Y1, Y2, W, O, G, H, ESD, NSB, OR, HP switch, and LOC switch); current or at time of fault the following temperatures - water coil (LT1), air coil (LT2), compressor discharge, leaving air, leaving water, entering water and control voltage; record last five faults, list possible reasons, and clear faults. When the AWC Thermostat is used this same functionality can be viewed and adjusted remotely with the only portal or mobile app. **Systems not providing remote access, diagnosis, and adjustment functionality will not be accepted.**

DIGITAL NIGHT SETBACK WITH PUMP RESTART (DXM2.5 W/ ATP32U03C/04C, AWC99U01)

The unit will be provided with a Digital Night Setback feature using an accessory relay on the DXM2.5 with an ATP32U03C/04C or AWC Thermostat and an external, field-provided time clock. The external time clock will initiate and terminate the night setback period. The thermostat will have a night setback override feature with a programmable override time period. An additional accessory relay on the unit DXM2.5 will energize the building loop pump control for the duration of the override period.

NOTE: This feature requires additional low voltage wiring. Consult Application Drawings for details.

REMOTE SERVICE SENTINEL (CXM2/DXM2.5)

Solid state control system shall communicate with applicable thermostats to display (at the thermostat) the unit status, fault status, and specific fault condition, as well as retrieve previously stored fault that caused unit shutdown. The Remote Service Sentinel allows building maintenance personnel or service personnel to diagnose unit from the wall thermostat. The control board shall provide a signal to the thermostat, indicating a lockout. A detailed message shall be provided at the communicating thermostat or service tool and specific fault status such as over/under voltage fault, high pressure fault, low pressure fault, low water temperature fault, condensate overflow fault, etc. **Units that do not provide this remote service sentinel shall not be acceptable.**

Option: MPC (Multiple Protocol Control) Interface System

Units shall have all the features listed above (either CXM2 or DXM2.5) and the control board will be supplied with a Multiple Protocol interface board. Available protocols are BACnet MS/TP, Modbus, or Johnson Controls N2. The choice of protocol shall be field selectable/changeable via the use of a simple selector switch. **Protocol selection shall not require any additional programming or special external hardware or software tools.** This will permit all units to be daisy-chain connected by a two-wire twisted pair shielded cable. The following points must be available at a central or remote computer location:

- a. Space temperature.
- b. Leaving-water temperature.
- c. Discharge-air temperature.
- d. Command-of-space temperature setpoint.
- e. Cooling status.
- f. Heating status.
- g. Low-temperature sensor alarm.
- h. Low-pressure sensor alarm.
- i. High-pressure switch alarm.
- j. Condensate-overflow alarm.
- k. High-/low-voltage alarm.

- l. Fan "ON/AUTO" position of space thermostat as specified above.
- m. Unoccupied / occupied command.
- n. Cooling command.
- o. Heating command.
- p. Fan "ON/AUTO" command.
- q. Fault-reset command.
- r. Itemized fault code revealing reason for specific shutdown fault (any one of seven).

This option also provides the upgraded 75VA control transformer with load side short circuit and overload protection via a built-in circuit breaker.

WARRANTY

ClimateMaster shall warranty equipment for a period of 12 months from start up or 18 months from shipping (whichever occurs first).

Option: Extended 4-year compressor warranty covers compressor for a total of 5 years.

Option: Extended 4-year refrigeration circuit warranty covers coils, reversing valve, expansion valve and compressor for a total of 5 years.

Option: Extended 4-year control board warranty covers the CXM2/DXM2.5 for a total of 5 years.

FIELD-INSTALLED OPTIONS

Hose Kits

All units shall be connected with hoses. The hoses shall be braided stainless steel; fire-rated hoses complete with adapters. Only fire-rated hoses will be accepted.

Valves

The following valves are available and will be shipped loose:

- a. Ball valve; bronze material, standard port full flow design, FPT connections.
- b. Ball valve with memory stop and PT port.
- c. "Y" strainer with blowdown valve; bronze material, FPT connections.

- d. Motorized water valve; slow acting, 24V, FPT connections.

Hose Kit Assemblies

The following assemblies ship with the valves already assembled to the hose described:

- a. Supply and return hoses having ball valve with PT port.
- b. Supply hose having ball valve with PT port; return hose having automatic flow regulator valve with PT ports, and ball valve.
- c. Supply hose having "Y" strainer with blowdown valve, and ball valve with PT port; return hose having automatic flow regulator with PT ports, and ball valve.
- d. Supply hose having "Y" strainer with blowdown valve, and ball valve with PT port; return hose having ball valve with PT port.

THERMOSTATS

The thermostat shall be a ClimateMaster mechanical or electronic type thermostat as selected below with the described features:

- a. **iGate 2 Communicating (AWC) Thermostat (AWC99U01)**

An electronic communicating web-enabled touchscreen thermostat shall be provided. The thermostat shall offer three stages of heating and two stages of cooling with precise temperature control and have a four-wire connection to the unit. The thermostat shall be capable of manual or automatic change-over operation and shall operate in standard or programmable mode. An integrated humidity control feature shall be included to control a humidifier and/or a dehumidifier. The thermostat shall include a utility demand reduction feature to be initiated by an independent time program or an external input. The thermostat shall provide access to via the web portal or mobile application to include temperature adjustment, schedule adjustment including occupied/unoccupied, entering-water temperature, leaving-water temperature, water-coil temperature, air-coil temperature, leaving-air temperature, and compressor-discharge temperature. A graphical system layout to

be provided with real-time operating mode information of the temperature sensors for easy diagnostics. The thermostat shall display system faults with probable cause and troubleshooting guidance. The system shall provide in clear language the last five faults, time of faults, operating temps at time of fault, and possible reasons for the fault. The thermostat shall provide access for immediate manual control of all outputs via the web portal/mobile application for rapid troubleshooting.

- b. **Single-Stage Digital Auto or Manual Changeover (ATA11U01)**

The thermostat shall be a single-stage, digital, auto or manual changeover with HEAT-OFF-COOL-AUTO system switch and fan ON-AUTO switch. The thermostat shall have an LCD display with temperature and setpoint(s) in °F or °C. The Thermostat shall provide permanent memory of setpoint(s) without batteries. A fault LED shall be provided to display specific fault condition. The thermostat shall provide temperature display offset for custom applications.

- c. **Multi-stage Manual Changeover Programmable 5/2 Day (ATP21W02)**

The thermostat shall be 5-day/2-day programmable (with up to four setpoints per day), multi-stage (2H/1C), manual changeover with HEAT-OFF-COOL-EM HEAT system settings and fan ON-AUTO settings. The thermostat shall have an LCD display with temperature, setpoint(s), mode, and status indication. The temperature indication shall be selectable for °F or °C. The thermostat shall provide permanent memory of setpoint(s) without batteries. The thermostat shall provide convenient override feature to temporarily change setpoint.

d. Multi-stage Automatic or Manual Changeover Programmable 7-Day (ATP32U03C)

The thermostat shall be 7-day programmable (with up to four setpoints per day), multi-stage (3H/2C), automatic or manual changeover with HEAT-OFF-COOL-AUTO-EM HEAT system settings and fan ON-AUTO settings. The thermostat shall have a blue backlit dot matrix LCD display with temperature, setpoints, mode, and status indication. The temperature indication shall be selectable for °F or °C. Time display shall be selectable for 12- or 24-hour clock. Fault identification shall be provided to simplify troubleshooting by providing specific unit fault at the thermostat with red backlit LCD during unit lockout. The thermostat shall provide permanent memory of setpoints without batteries. The thermostat shall provide heating-setpoint range limit, cooling-setpoint range limit, temperature display offset, keypad lockout, dead-band range setting, and inter-stage differential settings. The thermostat shall provide progressive recovery to anticipate the time required to bring space temperature to the next programmed event. The thermostat shall provide an installer setup for configuring options and for setup of servicing contractor name and contact information. The thermostat shall allow the use of an accessory remote and/or outdoor-temperature sensor (AST008). Thermostat navigation shall be accomplished via five buttons (up/down/right/left/select) with menu-driven selections for ease of use and programming.

e. Multi-stage Automatic or Manual Changeover Programmable 7-Day with Humidity Control (ATP32U04C)

The thermostat shall be 7-day programmable (with up to four setpoints per day), multi-stage (3H/2C), automatic or manual changeover with HEAT-OFF-COOL-AUTO-EM HEAT system settings and fan ON-AUTO settings. Separate dehumidification and humidification setpoints shall be configurable for discreet outputs to a dehumidification option and/or an external humidifier. Installer configuration mode shall allow the thermostat to operate with EC fan dehumidification mode via settings changes. The thermostat shall have a blue backlit dot matrix LCD display with temperature, relative humidity, setpoints, mode, and status indication. The temperature indication shall be selectable for °F or °C. Time display shall be selectable for 12- or 24-hour clock. Fault identification shall be provided to simplify troubleshooting by providing specific unit fault at the thermostat with red backlit LCD during unit lockout. The thermostat shall provide permanent memory of setpoints without batteries. Thermostat shall provide heating setpoint range limit, cooling setpoint range limit, temperature display offset, keypad lockout, dead-band range setting, and inter-stage differential settings. The thermostat shall provide progressive recovery to anticipate time required to bring space temperature to the next programmed event. The thermostat shall provide an installer setup for configuring options and for setup of servicing contractor name and contact information. The thermostat shall allow the use of an accessory remote and/or outdoor temperature sensor (AST008). Thermostat navigation shall be accomplished via five buttons (up/down/right/left/select) with menu-driven selections for ease of use and programming.

f. CM100 – Multi-stage Automatic or Manual Changeover digital thermostat (ATA32V01)

Multi-stage (3H/2C), automatic or manual changeover with HEAT-OFF-COOL-AUTO-EM HEAT system settings and fan ON-AUTO settings. The thermostat shall have a green backlit LED display with temperature, setpoints, mode, and status indication via a green (cooling) or red(heating) LED. The temperature indication shall be selectable for °F or °C. Time display shall be selectable for 12- or 24-hour clock. The thermostat shall provide permanent memory of setpoints without batteries. The thermostat shall provide heating-setpoint range limit, cooling-setpoint range limit, temperature display offset, keypad lockout, dead-band range setting, and inter-stage differential settings. The thermostat shall provide progressive recovery to anticipate time required to bring space temperature to the next programmed event. The thermostat shall provide an installer setup for configuring. Thermostat navigation shall be accomplished via four buttons (Mode/fan/down/up) with menu-driven selections for ease of use and programming.

g. CM300 – Multi-stage, Automatic or Manual Changeover, 7-day Programmable with Wi-Fi and Humidity Control (AVB32V02C/C)

The commercial version shall be 7-day programmable with four occupied/unoccupied periods per day with up to 4-hour override. Multi-stage (3H/2C), automatic or manual changeover with HEAT-OFF-COOL-AUTO-EM HEAT system settings and fan ON-AUTO settings, Wi-Fi, pre-occupancy purge fan option, nighttime control of display backlight, bi-color LED indicates a heating or cooling demand, keypad lock, title 24 compliant, openADR2.0b certified with Skyport web portal. Compatible with condensate-overflow warning systems – lockout compressor with message on.

h. CM500 – Color-Touchscreen Display, Multi-stage, Automatic or Manual Changeover, 7-day Programmable with Wi-Fi and Humidity Control (AVB32V03C/C)

The thermostat shall have color-resistive touchscreen display with space temperature, relative humidity, setpoints, mode, status indication and local weather (if connected to Wi-Fi). Residential version shall be 7-day programmable with up to four setpoints per day. The commercial version shall be 7-day programmable with four occupied/unoccupied periods per day with up to 4-hour override. Multi-stage (3H/2C), automatic or manual changeover with HEAT-OFF-COOL-AUTO-EM HEAT system settings and fan ON-AUTO settings, Wi-Fi, pre-occupancy purge fan option, customizable screen saver and background displays, indicator-on display indicates a heating or cooling demand, setpoint lock, title 24 compliant, openADR2.0b certified with Skyport web portal. Compatible with condensate-overflow warning systems – lockout compressor with message on the display. Capable of being monitored by third-party software. Compatible with AST014 Wi-Fi remote sensor. Configurator mobile app or web portal for easy setup. Separate dehumidification and humidification setpoints shall be configurable for discreet outputs to a dehumidification option and/or an external humidifier. The temperature indication shall be selectable for °F or °C. Time display shall be selectable for 12- or 24-hour clock. The thermostat shall provide permanent memory of setpoints without batteries. The thermostat shall provide heating setpoint-range limit, cooling setpoint-range limit, temperature display offset, dead-band range setting, and inter-stage differential settings. The thermostat shall provide progressive recovery to anticipate time required to bring space temperature to the next programmed event. The thermostat shall provide access to a web portal and mobile app for installer setup for configuring options. The thermostat shall have menu-driven selections for ease-of-use and programming.

DDC SENSORS

ClimateMaster wall-mounted DDC sensor to monitor room temperature and interfaces with optional interface system described above. Several types as described below:

- a. Sensor only with no display (MPC).
- b. Sensor with setpoint adjustment and override (MPC only).
- c. Sensor with setpoint adjustment and override, LCD display, status/fault indication (MPC).

Notice! This product specification document is furnished as a means to copy and paste ClimateMaster product information into project specification. It is not intended to be a complete list of product requirements. This document is an excerpt from the product catalog and must not be used without consulting the complete product catalog. For complete product installation and application requirements, please consult the complete product catalog. ClimateMaster is not responsible for misuse of this document or a failure to adequately review specific requirements in the product catalog.

Revision History

Models:
SR
006-060

Date	Section	Description
01/31/25	All	Updated naming conventions for CXM2, DXM2.5, and AWC Thermostat
	Standard Dimensional Data	Updated O and P measurements for sizes SR006-018
		Added shipping dimensions
		Added electrical heater knockout dimensions
	HGRH, Hybrid, and WSE Extended Cabinet Dimensional Data	Updated data
	Electrical Data	Updated data for SR036, SR042, and SR048
	Standard Correction Tables	Updated data
	Introduction	Added Hot Gas Reheat (HGRH) content
	Feature, Options, and Accessories	
	Engineering Specifications	
Hot Gas Reheat	Added section	
Hot Gas Reheat Sequence of Operations	Added section	
10/18/24	Blower Performance	Added a note concerning approved installation altitudes
	Performance Data	Updated Cooling EAT temperatures
	Engineering Specifications	Updated Unit Maximum Water Working Pressure
08/08/24	Minimum Installation Area	Updated Minimum Installation Area data
	Physical Data	Updated Unit Maximum Water Working Pressure
07/11/2024	Blower Data, Dimensional Data, Minimum Installation Area, Performance Data, Physical Data	Updated AHRI ratings
		Updated performance data for size 042
		Updated minimum installation area tables and values
		Updated blower data for sizes 006, 012, and 042
		Updated dimensional data for sizes 006-018
06/11/2024	Performance Data, Electrical Data	Updated AHRI ratings
		Updated performance data for standard sizes 006-060
		Updated electrical data and removed preliminary watermark from the cover
05/17/2024	Corner Weights, Electrical Data	Added corner weights for Hybrid and WSE units
		Updated electrical data for models equipped with EC blower motors and ISPs
05/14/2024	All	Added Hybrid sizes 24-60 and the WSE (36-60) options
03/06/2024	All	Added sizes 006-018
01/18/2024	All	Created



A NIBE GROUP MEMBER

7300 SW 44th St | Oklahoma City, OK 73179

Phone: 800.299.9747

www.climatemaster.com



ClimateMaster works continually to improve its products. As a result, the design and specifications of each product at the time of order may be changed without notice and may not be as described herein. Please contact ClimateMaster's Customer Service Department at 800-299-9747 for specific information on the current design and specifications. Statements and other information contained herein are not express warranties and do not form the basis of any bargain between the parties, but are merely ClimateMaster's opinion or commendation of its products. The latest version of this document is available at www.climatemaster.com. Engineered and assembled in the USA. © ClimateMaster, Inc. All Rights Reserved 2024