



A **NIBE** GROUP MEMBER



COMMERCIAL
TRANQUILITY® (SE) PREMIER SERIES

PRODUCT CATALOG

Revised: February 21, 2025

Models: SE 006-072
60Hz - R-454B

Preliminary

3	Introduction	35	Part Load Performance: Correction Tables
5	Features, Options, and Accessories	36	Full Load Performance: Correction Tables
6	iGate 2 Communicating Controls Powered by DXM2.5 Advanced Communicating Controls	37	Variable Pump Performance
7	iGate 2 Communicating (AWC) Thermostat	38	Antifreeze Correction Table
8	myUplink: Web and Mobile Interface	40	Water Pressure Drop Adder for Options: Correction Tables
9	vFlow Internal Variable Water Flow Control	41	Physical Data
11	Selection Procedure	43	Horizontal Service Access
13	Model Nomenclature	46	Vertical Service Access
14	Performance Data: AHRI/ASHRAE/ISO 13256-1	47	Dimensional Data
16	Performance Data: Selection Notes	51	Minimum Installation Area
17	Performance Data	52	Engineering Specifications
31	Blower Performance: CV EC Standard Unit	62	Revision History
32	Electrical Data		

THE TRANQUILITY (SE) PREMIER SERIES

The Tranquility (SE) Premier Series showcases superb efficiency ratings, quiet operation, and application flexibility that is synonymous with the ClimateMaster Tranquility family. The Tranquility SE surpasses ASHRAE 90.1 efficiency standards and utilizes R-454B low Global Warming Potential (GWP) refrigerant, setting a high standard for eco-friendly performance. Due to its innovative and environmentally-conscious design, the Tranquility SE qualifies for LEED® (Leadership in Energy and Environmental Design) points.

Available in sizes ½ ton (1.8 kW) through 6 tons (21.1 kW) with multiple cabinet options (vertical upflow, vertical downflow and horizontal) the Tranquility SE offers a wide range of units for most any installation. The Tranquility SE has an extended range refrigerant circuit, capable of ground loop (geothermal) applications as well as water loop (boiler-tower) applications. Some of the features of the innovative Tranquility SE series include: ultra-efficient two-stage unloading scroll compressor (single-stage for sizes 006-018), electronically commuted (EC) variable communicating blower motor, communicating microprocessor controls, galvanized steel cabinet, stainless steel drain pan, and foil-backed air handler insulation.

Recent EPA mandates require an industry transition to low-GWP refrigerants, such as R-454B which is a gas that is classified as having a low-toxicity, low-flammability rating. Due to these characteristics, R-454B systems charged with over 62 ounces of refrigerant must contain an integrated Refrigerant Detection System (RDS). In the unlikely event of a system-refrigerant leak, the RDS shuts down compressor operation and runs the unit blower motor to disperse any concentration of leaked refrigerant in compliance with UL 60335-2-40 safety standards. For Tranquility SE products, only the 5- and 6-ton sizes (060 and 072) are required to have the RDS and is optional on all other sizes.

ClimateMaster's exclusive double isolation compressor mounting system makes the Tranquility SE one of the quietest units on the market. Compressors are mounted on specially engineered sound tested EPDM grommets to a heavy gauge mounting plate, which is then isolated from the cabinet base with EPDM grommets to minimize vibration transmission and maximize sound attenuation. Multiple removable access panels and an easily accessible control box make installation and maintenance user friendly. Options such as DDC controls, internal variable speed pumps, modulating water valves, and high efficiency MERV rated air filters allow for customizable design solutions.

iGate® 2 technology provides technicians an interface into the operation of the system in real time without the need for hard tooling. On-board advanced controls communicate the key operating system temperatures allowing technicians to startup, commission, and service equipment remotely by smart phone or website interface. Communication can also be established at the unit via an AWC Thermostat or Wireless Service Tool. Not only does iGate 2 monitor current performance, it also allows the functionality to make system adjustments and captures operating conditions at time of fault. The data is presented in a user-friendly format, enhancing the overall usability of the experience.

vFlow® is ClimateMaster's variable water flow technology. It represents a major advancement in water flow system management efficiency. vFlow not only builds major water circulation components into the unit for a clean installation, it also intelligently varies water flow to minimize pump energy consumption and improve system reliability.

The heart of vFlow is either a variable speed pump (for ground loops) or modulating water valve (for ground water or central variable speed pumps) intelligently controlled with DXM2.5 Advanced Communicating Controls. Water flow is automatically varied based on changes in unit capacity level (stage) and source water temperature to maintain optimum system performance. vFlow allows the use of direct return piping, while eliminating external two-way valves and automatic flow regulators, making vFlow systems inherently self-balancing.

vFlow systems provide reduced water pumping power compared to traditional fixed-speed pumping systems. They also protect the unit against extreme operating conditions, thus extending the life of the compressor and air coil. Since vFlow is built inside the unit, it also saves on installation time and makes for a very clean and compact installation. The Tranquility SE Series water-source heat pumps are designed to meet the challenges of today's HVAC demands with one of the most innovative products available on the market.

FEATURES

- Sizes 006 (½ ton, 1.8 kW) through 072 (6 ton, 21.1 kW)
- Exceeds ASHRAE 90.1 efficiency standards
- Environmentally-friendly R-454B low-GWP refrigerant
- Refrigerant Detection System (RDS) (mandatory on sizes 060 and 072, optional for sizes 006-048)
- Intelligent Constant Volume (CV) EC motors for ultimate airflow control
- Part-load operation significantly lowers annual operating costs
- Galvanized-steel cabinet construction
- Foil-faced insulation in air handler section
- Unique double-isolation compressor mounting with vibration isolation for quieter operation
- Insulated divider plates separates the compressor and air-handler compartments
- TXV metering device
- Field-convertible discharge-air arrangement (horizontal configurations only)
- Eight standard safety features
- Easy-to-clean rust-prohibitive stainless-steel drain pan
- DXM2.5 Advanced Communicating Controls:
 - Multiple communication pathways for unit access and diagnosis:
 - Cloud-based remote monitoring via Wi-Fi communicating color-touchscreen thermostat
 - Connect directly to the system with the Wireless Service Tool
 - Provides real-time unit operating conditions
 - Reduces startup, commissioning, and service time by providing key system temperatures electronically
 - Captures operating conditions in the event of a safety shutdown
- Anti-short cycle and over/under-voltage protection
- Easy-access swing-out control box

- High-pressure, loss-of-charge, and condensate-overflow protection
- LED fault and status indication at controller
- Convenient service-tool access port for controller configuration and diagnostics located on the front corner post.
- Flush-mounted water fittings (backup wrench is not required)

OPTIONS

- BACnet, Modbus, and Johnson Controls N2 compatibility options for Building Management Systems (BMS)
- UltraQuiet sound-attenuation package
- Tin-plated air coils for added protection from formicary corrosion
- Domestic Hot Water Generator (HWG)
- vFlow unit-integrated variable-speed water pump for single-pipe systems
- vFlow unit-integrated modulating water valve for maximum water-flow control (replaces traditional motorized water valve and autoflow regulator)
- Extended-range insulation for geothermal applications

ACCESSORIES

- iGate 2 Communicating (AWC) Thermostat with color touchscreen
- Wide variety of thermostat options to meet your application needs
- Braided-hose kits in various lengths with optional water valve, PT plugs, blowdown valve, flow regulator, and strainer
- 1-inch Merv 8 filter
- 2-inch Merv 8 or 13 filters
- Aesthetically-pleasing wall sensors for connection to BMS (MPC) controls
- Auxiliary electric-duct heaters

iGate 2 Communicating Controls Powered by DXM2.5 Advanced Communicating Controls

Models:
SE
006-072

iGATE 2 COMMUNICATION – CLOUD CONNECTED, WEB-ENABLED INFORMATION GATEWAY TO MONITOR, CONTROL, AND DIAGNOSE YOUR SYSTEM

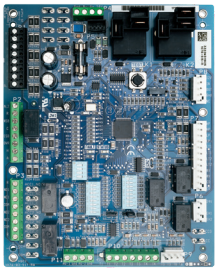

The Tranquility SE is equipped with industry-first, iGate 2 communication information gateway that allows users to interact with their water-source system in easy to read clear language AND delivers improved reliability and efficiency by precisely

controlling smart components.

Monitor/Configure: From the myUplink PRO website, mobile app, AWC Thermostat, or Wireless Service Tool, installers can configure the following: airflow, unit family, size, accessory configuration, and demand reduction (optional, to limit unit operation during peak times). Users can look up the current system status: temperature sensor readings and operational status of the blower.

Precise Control: The DXM2.5 enables intelligent, two-way communication between the DXM2.5 and smart components like the AWC Thermostat, Wireless Service Tool, and constant volume CV EC blower motor. DXM2.5 Advanced Communicating Controls uses information received from the smart components and temperature sensors to precisely control operation of the variable speed CV EC fan to deliver higher efficiency, reliability and increased comfort.

Diagnostics: iGate 2 takes diagnosing water-source heat pump units to a next level of simplicity, by providing a dashboard of system and fault information, in clear language, on the AWC Thermostat, Wireless Service Tool, and the web portal/mobile app on the internet.

iGate 2 Service Warnings notify the homeowner and contractor of a fault and displays fault descriptions by app notifications and email with possible causes. Additionally, the current system status can be viewed graphically on the web portal and mobile app.

In iGate 2 Service Mode, the service personnel can access fault description, possible causes and most importantly, the conditions (temp, flow, i/o conditions, configuration) at the time of the fault. Manual Operation mode allows the service personnel to manually command operation for any of the thermostat outputs, blower speed, to help troubleshoot specific components. This operation can either be conducted at the unit with a Wireless Service Tool or remotely with mobile app/website when AWC Thermostat controls are used.

With an iGate 2 communicating system, users and contractors have a web-enabled gateway to system information never before available and exclusive to ClimateMaster products.

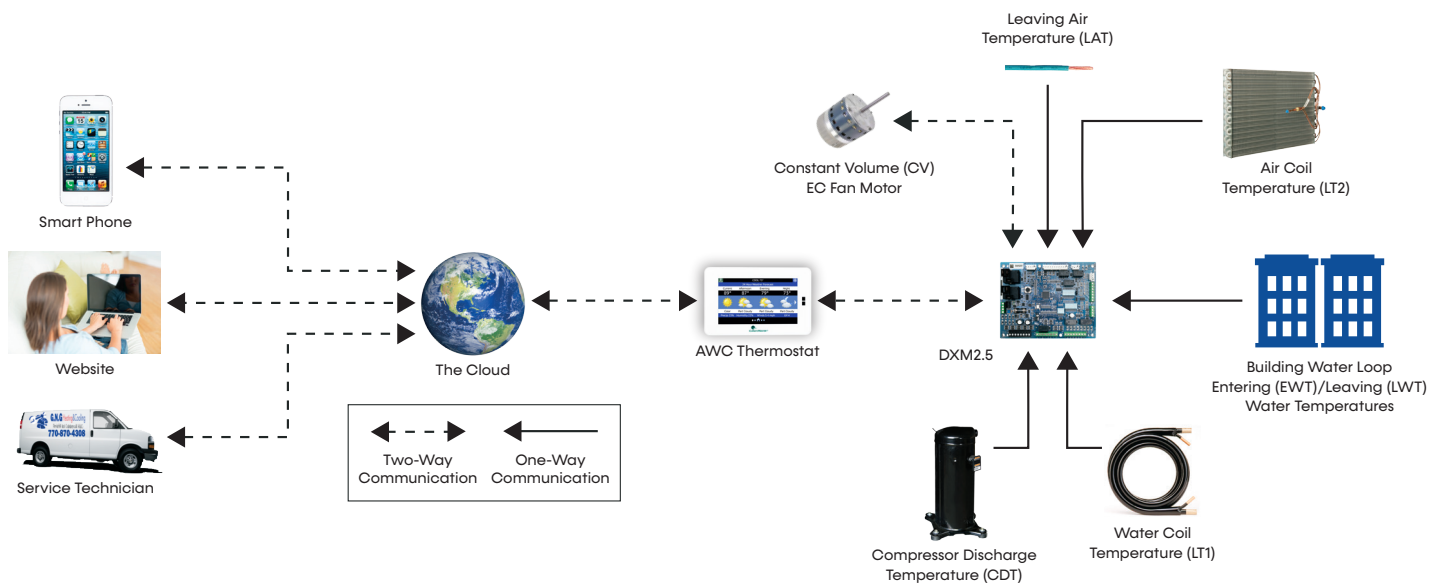

ClimateMaster works continually to improve its products. As a result, the design and specifications of each product at the time of order may be changed without notice and may not be as described herein. Please contact ClimateMaster's Customer Service Department at 1-800-299-9747 for specific information on the current design and specifications. Statements and other information contained herein are not express warranties and do not form the basis of any bargain between the parties, but are merely ClimateMaster's opinion or commendation of its products. The latest version of this document is available at www.climatemaster.com. Engineered and assembled in the USA. © ClimateMaster, Inc. All Rights Reserved 2024

iGate 2 Communicating (AWC) Thermostat

Models:
SE
006-072

iGATE 2 COMMUNICATION – CLOUD CONNECTED, WEB-ENABLED INFORMATION GATEWAY TO MONITOR, CONTROL, AND DIAGNOSE YOUR SYSTEM

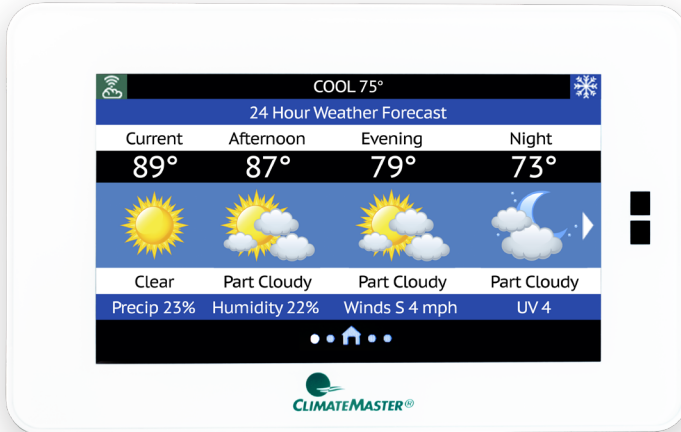

The iGate 2 Communicating (AWC) Thermostat is innovating the future of comfort technology, one building at a time. The inspired design of the touch screen interface allows you to see real-time data for the efficiency and health of your system, with early warnings for potential system faults. The cloud based information gateway allows technicians to remotely diagnose system issues before occupants even know there is a problem. Control and monitor the system in your home or business from anywhere in the world with an easy to use app on your phone.

Features with Efficiency in Mind



Touchscreen Interface

A brilliantly customizable touchscreen monitor for simple control.



Seamless Integration

Between your AWC Thermostat and comfort system.



(Mobile) Remote System Control

Control temperature and schedule from anywhere in the world.



Early Fault Warnings

Alerts the building owner and the contractor of potential system faults in the future.



Remote Diagnostics

Enable the contractor to remotely diagnose system issues, adjust system settings, and reset faults.



Real-Time Operations Data and System Schematics

Access simply via the myUplink Pro Account and web portal to view system diagrams with current operating temperatures.



Revenue Stream

HVAC professionals can offer owners service contracts with remote monitoring and diagnostic capabilities without the large expense of a building management system.



ClimateMaster works continually to improve its products. As a result, the design and specifications of each product at the time of order may be changed without notice and may not be as described herein. Please contact ClimateMaster's Customer Service Department at 1-800-299-9747 for specific information on the current design and specifications. Statements and other information contained herein are not express warranties and do not form the basis of any bargain between the parties, but are merely ClimateMaster's opinion or commendation of its products. The latest version of this document is available at www.climatemaster.com. Engineered and assembled in the USA. © ClimateMaster, Inc. All Rights Reserved 2024

HVAC Professional | User Experience

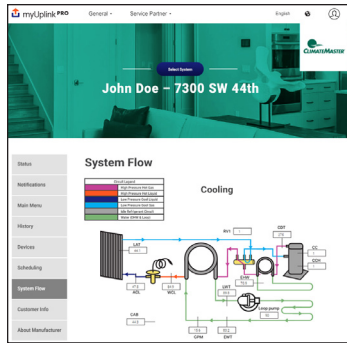

iGate 2 establishes a two-way link between the AWC Thermostat and the cloud, adding significant value for both residential and commercial customers. Our new thermostat works with your customers' Tranquility comfort systems to

provide the most efficient link between their system and your services. The customizable monitoring from the myUplink PRO web portal or phone app account allows for continuous system monitoring, analysis, repair recognition, and early warnings for potential system faults that are sent to you and your customer.



Benefits

- Remote login from anywhere, anytime from any internet connected device
- View system fault history with possible root causes
- Information is available for contractors to troubleshoot and diagnose systems remotely
- Secure internet connection keeps homeowner information private
- Access thermostat(s) through Android and iPhone mobile apps

Homeowner | User Experience

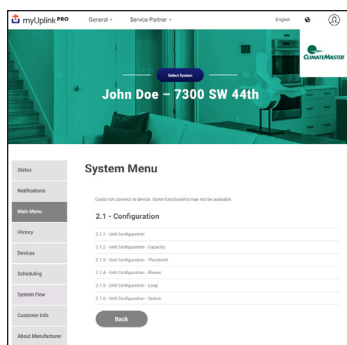

iGate 2 advanced unit controls enable a two-way communication link for critical system information between the unit and the cloud. From any internet connected device or smart phone, building owners can control and monitor their systems

from anywhere in the world. iGate 2 offers building owners peace of mind their systems are operating at peak performance with advanced operational performance issue notifications. HVAC professionals get notifications when systems are operating out of range. They can log in remotely to check system faults, review current operating conditions, and diagnose issues remotely. This gives the HVAC technician the upper hand when showing up to perform service, saving time which in turn, saves money.



Benefits

- Communicates personal settings and reminders through the iGate 2 communication system
- Easy-to-use, full-color, high-resolution user interface
- Sleek, intuitive control panel
- Secure internet connection keeps your information private
- Contains unit model, serial number and your HVAC professionals contact information
- System monitoring automatically contacts HVAC system providers when service is needed

vFLOW INTERNAL VARIABLE WATER FLOW

Industry-first, built-in vFlow replaces a traditionally inefficient, external component of the system (water circulation) with an ultra-high-efficient, variable-speed, internal water-flow system. This saves 70-80% on water circulation compared to traditional single-speed pump systems. Multi-unit installations are also much simpler with vFlow systems, as the units automatically adjust water flow across the system.

vFlow is enabled by iGate 2, which facilitates intelligent communication between the thermostat, DXM2.5, sensors, and internal water pump/valve to make true variable water flow a reality.

vFLOW IS AVAILABLE IN FOUR VARIATIONS:

1. Low System Pressure Drop Modulating Valve – High CV motorized valve for central pumping. (Standard unit).
2. High System Pressure Drop Modulating Valve – Motorized valve for higher-pressure water systems, such as water well pumps (optional).
3. Standard Head Variable Pump – multi unit/central pumping (optional).
4. High Head Variable Pump – multi/individual unit pumping (optional).

vFLOW DELIVERS THREE MAIN BENEFITS:

1. Easier and quicker unit installation as the flow control is built in to the unit.
2. Superior reliability by varying the water flow to deliver more stable operation.
3. Increased cost savings by varying the flow (and pump watt consumption) to match the unit's mode of operation.

INTERNAL COMPONENTS

All Tranquility products can be installed more easily and compactly than their predecessors because vFlow components are internal to the unit. They also save installing contractors labor and time by eliminating the need for an external flow regulator or a bulky external pumping module.

VARIABLE FLOW

vFlow technology enables variable water flow through the unit, with the DXM2.5 adjusting the pump speed to maintain an installer-set loop delta T. By controlling the water flow, the system is able to operate at its optimal capacity and efficiency. vFlow provides a lower flow rate for part load where units typically operate 80% of the time and a higher, more normal flow rate for full-load operation.

The variable-speed pump or motorized modulating valve delivers variable water-flow, controlled by DXM2.5, based on loop water ΔT .



ENERGY SAVINGS WITH WATER CIRCULATION CONTROL

Units with vFlow deliver greater operating cost savings by varying the water flow to match the unit's operation (ex: lower water flow when unit is in part-load operation). Lowering the flow results in lower energy consumption by the water pump (=greater cost savings) in vFlow units (whether internal or external pump).

In applications using vFlow with internal variable speed electronically commuted (EC) pump, the EC pump uses fewer watts than a fixed speed (PSC) pump even at full load. The EC pump excels in energy savings in part load, saving 70-80% watts compared to fixed speed pumps (see chart). The EC pump can operate with independent flow rates for both heating and cooling operations allowing for more energy savings.

In loop applications, when the motorized modulating valve slows down the water flow during part-load operation, the external pump consumes fewer watts, thus saving more energy.

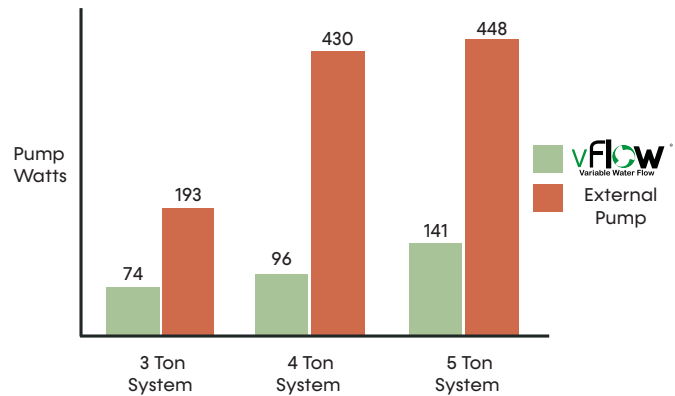

Reference Calculations

Heating	Cooling
$LWT = EWT - \frac{HE}{GPM \times \text{Constant}}$	$LWT = EWT + \frac{HR}{GPM \times \text{Constant}} \quad LC = TC - SC$
$LAT = EAT + \frac{HC}{CFM \times 1.08}$	$LAT (DB) = EAT (DB) - \frac{SC}{CFM \times 1.08} \quad S/T = \frac{SC}{TC}$

Constant = 500 for water, 485 for antifreeze

Conversion Table - to convert inch-pound (English) to S-I (Metric)

Airflow	Water Flow	External Static Pressure	Water Pressure Drop
Airflow (L/s) = CFM x 0.472	Water Flow (L/s) = GPM x 0.0631	ESP (Pa) = ESP (in of wg) x 249	PD (kPa) = PD (ft of hd) x 2.99

Legend and Glossary of Abbreviations

Abbreviations	Descriptions
Btuh	Btu (British Thermal Unit) per hour
BMS	Building Management System
CDT	Compressor discharge temperature
CFM	Airflow, cubic feet per minute
COP	Coefficient of performance = Btuh output/Btuh input
CT EC	Electronically commutated constant torque blower motor
CV EC	Electronically commutated constant volume blower motor
DB	Dry bulb temperature, °F
DT	Delta T
EAT	Entering air temperature
EER	Energy efficient ratio = Btuh output/Watt input
ESP	External static pressure, inches w.g.
EWT	Entering water temperature
FPT	Female pipe thread
GPM	Water flow in U.S., gallons per minute
HC	Air heating capacity, Btuh
HE	Total heat of extraction, Btuh
HGRH	Hot Gas Reheat

Abbreviations	Descriptions
HR	Total heat of rejection, Btuh
HWG	Hot water generator (desuperheater) capacity, MBtuh
kW	Total power unit input, kilowatts
LAT	Leaving air temperature, °F
LC	Latent cooling capacity, Btuh
LOC	Loss of charge
LWT	Leaving water temperature, °F
MBtuh	1,000 Btu per hour
MPT	Male pipe thread
MWV	Motorized water valve
PSC	Permanent split capacitor
RDS	Refrigerant Detection System
SC	Sensible cooling capacity, Btuh
S/T	Sensible to total cooling ratio
TC	Total cooling capacity, Btuh
TD or delta T	Temperature differential
VFD	Variable frequency drive
WB	Wet bulb temperature, °F
WPD	Waterside pressure drop, psi or feet of head
WSE	Waterside economizer

ClimateMaster works continually to improve its products. As a result, the design and specifications of each product at the time of order may be changed without notice and may not be as described herein. Please contact ClimateMaster's Customer Service Department at 1-800-299-9747 for specific information on the current design and specifications. Statements and other information contained herein are not express warranties and do not form the basis of any bargain between the parties, but are merely ClimateMaster's opinion or commendation of its products. The latest version of this document is available at www.climatemaster.com. Engineered and assembled in the USA. © ClimateMaster, Inc. All Rights Reserved 2024

USE THE FOLLOWING SELECTION STEPS

1. Determine the actual heating and cooling loads at the desired dry bulb and wet bulb conditions.
2. Obtain the following design parameters: Entering water temperature, water flow rate in GPM, airflow in CFM, water flow pressure drop and design wet and dry bulb temperatures. Airflow CFM should be between 300 and 450 CFM per ton. Unit water pressure drop should be kept as close as possible to each other to make water balancing easier. Go to the appropriate tables and find the proper indicated water flow and water temperature.
3. Select a unit based on total and sensible cooling conditions. Select a unit which is closest to, but no larger than, the actual cooling load.
4. Enter tables at the design water flow and water temperature. Read the total and sensible cooling capacities

Note: interpolation is permissible, extrapolation is not.

5. Read the heating capacity. If it exceeds the design criteria it is acceptable. It is quite normal for water-source heat pumps to be selected on cooling capacity only since the heating output is usually greater than the cooling capacity.
6. Determine the correction factors associated with the variable factors of dry bulb and wet bulb.

Corrected Total Cooling =
tabulated total cooling x wet bulb correction.

Corrected Sensible Cooling =
tabulated sensible cooling x wet/dry bulb correction.

7. Compare the corrected capacities to the load requirements. Normally if the capacities are within 10% of the loads, the equipment is acceptable. It is better to undersize than oversize, as undersizing improves humidity control, reduces sound levels and extends the life of the equipment.
8. When completed, calculate water temperature rise and assess the selection. If the units selected are not within 10% of the load calculations, then review what effect changing the GPM, water temperature and/or air flow and air temperature would have on the corrected capacities. If the desired capacity cannot be achieved, select the next larger or smaller unit and repeat the procedure. Remember, when in doubt, undersize slightly for best performance.

EXAMPLE EQUIPMENT SELECTION FOR COOLING

Step 1: Load Determination

Assume we have determined that the appropriate cooling load at the desired dry bulb 80°F and wet bulb 65°F conditions is as follows:

Total Cooling 22,000 Btuh
Sensible Cooling 18,200 Btuh
Entering Air Temp..... 80°F Dry Bulb / 65°F Wet Bulb

Step 2: Design Conditions

Similarly, we have also obtained the following design parameters:

Entering Water Temp 90°F
Water Flow (Based upon 10°F rise in temp) .4.5 GPM
Airflow 600 CFM

Steps 3, 4, and 5: HP Selection

After making our preliminary selection (SE024), we enter the tables at design water flow and water temperature and read Total Cooling, Sensible Cooling and Heat of Rejection capacities:

Total Cooling 22,500 Btuh
Sensible Cooling 16,500 Btuh
Heat of Rejection 28,800 Btuh

Steps 6 and 7: Entering Airflow Corrections

Next, we determine our correction factors.

Corrected Values	Table	Ent Air	Airflow	Corrected
Corrected Total Cooling	= 22,500 x	0.976	x 0.967	= 21,235
Corrected Sensible Cooling	= 16,500 x	0.919	x 1.089	= 16,513
Corrected Heat of Rejection	= 28,800 x	0.969	x 0.972	= 27,126

Step 8: Water Temperature Rise Calculation and Assessment

Actual Temperature Rise 12.1°F

When we compare the Corrected Total Cooling and Corrected Sensible Cooling figures with our load requirements stated in Step 1, we discover that our selection is within ±10% of our sensible load requirement. Furthermore, we see that our Corrected Total Cooling figure is within 1,000 Btuh the actual indicated load.

ClimateMaster works continually to improve its products. As a result, the design and specifications of each product at the time of order may be changed without notice and may not be as described herein. Please contact ClimateMaster's Customer Service Department at 1-800-299-9747 for specific information on the current design and specifications. Statements and other information contained herein are not express warranties and do not form the basis of any bargain between the parties, but are merely ClimateMaster's opinion or commendation of its products. The latest version of this document is available at www.climatemaster.com. Engineered and assembled in the USA. © ClimateMaster, Inc. All Rights Reserved 2024

Model Nomenclature

Models:
SE
006-072

1 | 2 | 3 | 4 | 5 | 6 | 7 | 8 | 9 | 10 | 11 | 12 | 13 | 14 | 15
S | **E** | **L** | **O** | **2** | **4** | **A** | **G** | **D** | **K** | **O** | **C** | **O** | **V** | **S**

PRODUCT NAME

S = R-454B Refrigerant

MODEL TYPE

E = Premier Series

SUPPLY & RETURN CONFIGURATIONS

Left Horizontal

L = Straight
B = Back

Right Horizontal

R = Straight
P = Back

Down Flow

D = Left, Down
N = Right, Down

Vertical

T = Left, Top
K = Right, Top

SIZE

006 036
009 048
012 060
018 072
024

REVISION

A = Current

VOLTAGE

G = 208/230-1-60 J = 208/230-1-60 Refrigerant Detection System
H = 208/230-3-60 K = 208/230-3-60 Refrigerant Detection System
E = 265-1-60 D = 265-1-60 Refrigerant Detection System
F = 460-3-60 L = 460-3-60 Refrigerant Detection System

CONTROLS

Control	Standard	MPC
DXM2.5	D	P
DXM2.5 with Disconnect	B	S

STANDARD

S = Standard

BLOWER MOTOR

V = Constant Volume (CV) EC Motor

EXTENDED OPTIONS

O = Standard
G = Hot Water Generator

DRAIN PAN/HEAT EXCHANGER OPTIONS

S = Stainless Steel Drain Pan, Non-Coated Air Coil
R = Stainless Steel Drain Pan, Tin-Coated Air Coil

WATER/HEAT EXCHANGER OPTIONS

Water Option	Standard	Cupro Nickel
None	0	Z
Modulating Water Valve	C	P
Internal Secondary Pump (ISP)	7	-
Internal Pump Standard Head with Check Valve (Variable)	3	-
Internal Pump High Head with Check Valve (Variable)	4	-
Internal Pump Standard Head without Check Valve (Variable)	J	-
Internal Pump High Head without Check Valve (Variable)	K	-

CABINET

	Ultra Quiet	Rail		Frame	
		1"	2"	1"	2"
Commercial Extended Range	No	1	J	K	A
	Yes	2	L	M	C
Commercial Standard Range	No	3	N	P	E
	Yes	4	F	S	G

ClimateMaster works continually to improve its products. As a result, the design and specifications of each product at the time of order may be changed without notice and may not be as described herein. Please contact ClimateMaster's Customer Service Department at 1-800-299-9747 for specific information on the current design and specifications. Statements and other information contained herein are not express warranties and do not form the basis of any bargain between the parties, but are merely ClimateMaster's opinion or commendation of its products. The latest version of this document is available at www.climatemaster.com. Engineered and assembled in the USA. © ClimateMaster, Inc. All Rights Reserved 2024

Performance Data: AHRI/ASHRAE/ISO 13256-1

Models:
SE
006-072

ASHRAE/AHRI/ISO 13256-1 English (I-P) Units

Model	Motor Type	WSHP (Part Load)											
		Water Loop Heat Pump				Ground Water Heat Pump				Ground Loop Heat Pump			
		Cooling 86°F		Heating 68°F		Cooling 59°F		Heating 50°F		Cooling 68°F		Heating 41°F	
		Capacity Btuh	EER Btuh/W	Capacity Btuh	COP	Capacity Btuh	EER Btuh/W	Capacity Btuh	COP	Capacity Btuh	EER Btuh/W	Capacity Btuh	COP
SE024	EC	17,900	19.2	20,100	6.6	20,200	36.2	17,100	5.7	19,400	27.9	18,900	4.4
SE036	EC	26,400	20.2	30,600	6.5	30,200	35.3	25,800	5.6	28,500	29.7	22,700	5.0
SE048	EC	35,700	19.6	42,900	6.5	41,000	41.8	33,700	5.3	37,400	28.6	29,000	4.7
SE060	EC	42,200	18.9	44,800	5.9	48,000	32.9	35,900	4.8	46,400	27.5	30,900	4.1
SE072	EC	53,500	17.9	59,200	5.4	61,400	34.8	48,000	4.5	58,000	24.1	42,400	4.1

Notes:

- Where dual voltages are available ratings are based on the lower voltage setting.
- Cooling capacities based upon 80.6°F DB, 66.2°F WB entering air temperature.
- Heating capacities based upon 68°F DB, 59°F WB entering air temperature.
- Ground Loop Heat Pump ratings based on 15% antifreeze solution.

Tested in Accordance with ASHRAE/AHRI/ISO 13256-1 English (I-P) Units

Model	Motor Type	WSHP (Full Load)											
		Water Loop Heat Pump				Ground Water Heat Pump				Ground Loop Heat Pump			
		Cooling 86°F		Heating 68°F		Cooling 59°F		Heating 50°F		Full Cooling 77°F		Full Heating 32°F	
		Capacity Btuh	EER Btuh/W	Capacity Btuh	COP	Capacity Btuh	EER Btuh/W	Capacity Btuh	COP	Capacity Btuh	EER Btuh/W	Capacity Btuh	COP
SE006	EC	6,111	15.5	7,760	5.3	7,178	28.0	6,111	4.4	6,499	18.2	4,656	3.3
SE009	EC	9,021	14.8	10,767	4.9	10,767	24.4	8,730	4.3	9,700	17.6	6,887	3.4
SE012	EC	11,349	15.2	13,386	4.8	12,901	25.6	11,446	4.2	11,931	17.6	9,215	3.4
SE018	EC	18,624	16.0	22,601	5.7	21,437	25.5	18,333	4.8	19,594	18.8	14,065	3.8
SE024	EC	25,300	17.1	29,000	5.7	28,600	26.2	23,400	5.0	26,300	19.9	17,800	4.1
SE036	EC	37,500	17.0	43,100	5.4	41,000	24.4	35,700	4.9	39,000	18.8	28,400	4.2
SE048	EC	48,000	17.2	60,200	5.3	54,600	26.0	49,100	4.5	51,700	19.4	38,100	3.9
SE060	EC	61,800	16.9	67,300	5.3	66,800	24.7	55,700	4.7	62,600	18.7	44,300	3.9
SE072	EC	72,000	16.1	81,400	4.9	77,000	22.4	67,400	4.4	74,700	18.4	54,000	3.8

Notes:

- Where dual voltages are available ratings are based on the lower voltage setting.
- Cooling capacities based upon 80.6°F DB, 66.2°F WB entering air temperature.
- Heating capacities based upon 68°F DB, 59°F WB entering air temperature.
- Ground Loop Heat Pump ratings based on 15% antifreeze solution.

Performance Data: AHRI/ASHRAE/ISO 13256-1

Models:
SE
006-072

ASHRAE/AHRI/ISO 13256-1 Metric (S-I) Units

Model	Motor Type	WSHP (Part Load)											
		Water Loop Heat Pump				Ground Water Heat Pump				Ground Loop Heat Pump			
		Cooling 30°C		Heating 20°C		Cooling 15°C		Heating 10°C		Full Cooling 20°C		Full Heating 5°C	
		Capacity kW	EER W/W	Capacity kW	COP	Capacity kW	EER W/W	Capacity kW	COP	Capacity kW	EER W/W	Capacity kW	COP
SE024	EC	5	5.6	6	6.6	6	10.6	5	5.7	6	8.2	6	4.4
SE036	EC	8	5.9	9	6.5	9	10.4	8	5.6	8	8.7	7	5.0
SE048	EC	10	5.7	13	6.5	12	12.3	10	5.3	11	8.4	8	4.7
SE060	EC	12	5.5	13	5.9	14	9.6	11	4.8	14	8.1	9	4.1
SE072	EC	16	5.2	17	5.4	18	10.2	14	4.5	17	7.1	12	4.1

Notes:

- Where dual voltages are available ratings are based on the lower voltage setting.
- Cooling capacities based upon 20°C DB, 15°C WB entering air temperature.
- Heating capacities based upon 20°C DB, 15°C WB entering air temperature.
- Ground Loop Heat Pump ratings based on 15% antifreeze solution.

Tested in Accordance with ASHRAE/AHRI/ISO 13256-1 Metric (S-I) Units

Model	Motor Type	WSHP (Full Load)											
		Water Loop Heat Pump				Ground Water Heat Pump				Ground Loop Heat Pump			
		Cooling 30°C		Heating 20°C		Cooling 15°C		Heating 10°C		Full Cooling 25°C		Full Heating 0°C	
		Capacity kW	EER W/W	Capacity kW	COP	Capacity kW	EER W/W	Capacity kW	COP	Capacity kW	EER W/W	Capacity kW	COP
SE006	EC	2	4.5	2	5.5	2	8.2	2	4.5	2	5.3	1	3.4
SE009	EC	3	4.3	3	5.1	3	7.2	3	4.4	3	5.1	2	3.5
SE012	EC	3	4.5	4	4.9	4	7.5	3	4.3	3	5.1	3	3.5
SE018	EC	5	4.7	7	5.9	6	7.5	5	4.9	6	5.5	4	3.9
SE024	EC	7	5.0	8	5.7	8	7.7	7	5.0	8	5.8	5	4.1
SE036	EC	11	5.0	13	5.4	12	7.2	10	4.9	11	5.5	8	4.2
SE048	EC	14	5.0	18	5.3	16	7.6	14	4.5	15	5.7	11	3.9
SE060	EC	18	5.0	20	5.3	20	7.2	16	4.7	18	5.5	13	3.9
SE072	EC	21	4.7	24	4.9	23	6.6	20	4.4	22	5.4	16	3.8

Notes:

- Where dual voltages are available ratings are based on the lower voltage setting.
- Cooling capacities based upon 27°C DB, 19°C WB entering air temperature.
- Heating capacities based upon 20°C DB, 15°C WB entering air temperature.
- Ground Loop Heat Pump ratings based on 15% antifreeze solution.

Performance Data: Selection Notes

Models:
SE
006-072

For operation in the shaded area when water is used instead of an antifreeze solution, the LWT (Leaving Water Temperature) must be calculated. Flow must be maintained to a level such that the LWT is maintained above 40°F (4.4°C) when the JW3 jumper is not clipped (see example below). Otherwise, appropriate levels of a proper antifreeze solution should be used in systems with leaving water temperatures of 40°F (4.4°C) or below and the JW3 jumper should be clipped. This is due to the potential of the refrigerant temperature being as low as 32°F (0°C) with 40°F (4.4°C) LWT, which may lead to a nuisance cutout due to the activation of the Low Temperature Protection. JW3 should never be clipped for standard-range equipment or systems without antifreeze.

Example:

At 50°F EWT (Entering Water Temperature) and 1.5 GPM/ton, a 3-ton unit has a HE of 22,500 Btuh. To calculate LWT, rearrange the formula for HE as follows:

$HE = TD \times GPM \times 500$, where HE = Heat of Extraction (Btuh); TD = temperature difference (EWT - LWT) and GPM = U.S. Gallons per Minute.

$$TD = HE / (GPM \times 500)$$

$$TD = 22,500 / (1.5 \times 500)$$

$$TD = 10^\circ F$$

$$LWT = EWT - TD$$

$$LWT = 50 - 10 = 40^\circ F$$

In this example, as long as the EWT does not fall below 50°F, the system will operate as designed. For EWTs below 50°F, higher flow rates will be required (open loop systems, for example, require at least 2 GPM/ton when EWT is below 50°F).

		Heating - EAT 70°F					
		EER	HC	Power kW	HE	LAT	COP
Not Recommended							
			4.0	0.45	2.5	84.6	2.6
8.6	27.4	4.6	0.46	3.0	86.8	2.9	
8.6	31.0	4.8	0.47	3.2	87.8	3.0	
8.6	33.0	4.9	0.47	3.3	88.3	3.1	
8.4	23.3	5.4	0.48	3.8	90.2	3.3	
8.5	26.3	5.7	0.49	4.0	91.4	3.4	
8.6	27.9	5.9	0.49	4.2	92.1	3.5	
8.2	19.8	6.2	0.50	4.5	93.6	3.7	
4	22.3	6.6	0.50	4.9	95.0	3.8	
	23.7	6.8	0.51	5.0	95.8	3.9	
	16.7	7.0	0.51	5.3	96.9	4.0	
	18.8	7.4	0.52	5.6	98.5	4.1	
		7.6	0.52	5.8	99.3	4.2	
			0.53	6.0	100.0	4.3	

Performance Data SE*006 EC Blower Motor

Models:
SE
006-072

240 CFM Rated Airflow

EWT °F	FLOW GPM	WPD		COOLING - EAT 80/67 °F						HEATING - EAT 70°F				
		PSI	FT	TC	SC	kW	HR	EER	HWG Cap	HC	KW	HE	COP	HWG Cap
20	2.0	3.2	7.4	Operation Not Recommended						3.6	0.4	2.4	2.9	
30	1.0	0.3	0.7	6.7	4.9	0.2	7.5	26.9	4.3	0.4	3.1	3.5		
	1.5	1.6	3.7	6.9	4.9	0.2	7.7	27.7	4.5	0.4	3.3	3.6		
	2.0	3.0	6.9	7.0	4.9	0.2	7.8	28.0	4.6	0.4	3.4	3.7		
40	1.0	0.3	0.7	7.0	5.1	0.2	7.8	28.0	5.4	0.5	3.8	3.4		
	1.5	1.5	3.5	7.0	5.1	0.2	7.8	28.0	5.6	0.5	4.0	3.5		
	2.0	2.8	6.5	7.1	5.1	0.2	7.9	28.4	5.7	0.5	4.1	3.6		
50	1.0	0.3	0.7	6.9	5.3	0.2	7.7	27.7	6.1	0.5	4.5	3.8		
	1.5	1.4	3.2	7.0	5.3	0.2	7.8	28.0	6.4	0.5	4.8	4.0		
	2.0	2.6	6.0	7.1	5.3	0.2	7.9	28.4	6.5	0.5	4.9	4.1		
60	1.0	0.2	0.5	6.7	5.4	0.3	7.9	19.2	6.8	0.5	5.2	4.3		
	1.5	1.3	3.0	6.9	5.4	0.2	7.7	27.7	7.1	0.5	5.5	4.4		
	2.0	2.4	5.5	6.9	5.5	0.2	7.7	27.7	7.2	0.5	5.6	4.5		
70	1.0	0.2	0.5	6.3	5.3	0.3	7.5	18.1	7.5	0.5	5.9	4.7		
	1.5	1.2	2.8	6.6	5.4	0.3	7.8	18.9	7.7	0.5	6.1	4.8		
	2.0	2.2	5.1	6.7	5.4	0.3	7.9	19.2	7.8	0.5	6.3	4.9		
80	1.0	0.2	0.5	5.9	5.1	0.3	7.1	17.0	8.1	0.5	6.5	5.1		
	1.5	1.1	2.5	6.1	5.2	0.3	7.3	17.5	8.4	0.5	6.8	5.3		
	2.0	2.0	4.6	6.2	5.3	0.3	7.4	17.8	8.6	0.5	7.0	5.4		
90	1.0	0.2	0.5	5.4	4.9	0.4	7.0	12.1	8.8	0.5	7.2	5.5		
	1.5	1.0	2.3	5.6	5.0	0.4	7.2	12.5	9.3	0.5	7.7	5.9		
	2.0	1.8	4.2	5.8	5.1	0.4	7.4	13.0	9.6	0.5	8.0	6.0		
100	1.0	0.1	0.2	4.9	4.7	0.5	6.8	9.0						
	1.5	0.8	1.8	5.1	4.8	0.4	6.7	11.4						
	2.0	1.6	3.7	5.2	4.9	0.4	6.8	11.7						
110	1.0	0.1	0.2	4.4	4.3	0.5	6.2	8.0						
	1.5	0.7	1.6	4.7	4.5	0.5	6.5	8.5	Operation Not Recommended					
	2.0	1.4	3.2	4.8	4.5	0.5	6.6	8.7	Operation Not Recommended					
120	1.0	0.1	0.2	4.0	4.0	0.6	6.2	6.1						
	1.5	0.6	1.4	4.2	4.1	0.5	6.0	7.6						
	2.0	1.2	2.8	4.3	4.2	0.5	6.1	7.8						

- Interpolation is permissible; extrapolation is not.
- All entering air conditions are 80°F (26.6°C) DB and 67°F (19.4°C) WB in cooling, and 70°F (21°C) DB in heating.
- AHRI/ISO certified conditions are 80.6°F (27°C) DB and 66.2°F (19°C) WB in cooling and 68°F (20°C) DB in heating.
- Table does not reflect fan or pump power corrections for AHRI/ISO conditions.
- Performance stated is at the rated power supply; performance may vary as the power supply varies from the rated.
- Operation below 40°F (10.0°C) EWT is based upon 20% methanol antifreeze solution.
- Operation below 60°F (15.5°C) EWT requires optional insulated water/refrigerant circuit.
- See performance correction tables for operating conditions other than those listed above.
- See Performance Data Selection Notes for operation in the shaded areas.
- Regular Cooling operation with an EWT of less than 50°F (10.0°C) is not recommended unless variable water flow is available.
- Regular Heating operation with an EWT of more than 90°F (32°C) is not recommended unless variable water flow is available.
- For quiet operation and long term reliability, it is recommended that systems be designed to avoid continuous operation in the outlined areas.
- Performance capacities shown in thousands of Btu/h
- Hot Water Generator Capacity is based on 90°F entering water and 0.5 GPM/Ton.

Performance Data SE*009 EC Blower Motor

Models:
SE
006-072

300 CFM Rated Airflow

EWT °F	FLOW GPM	WPD		COOLING - EAT 80/67 °F						HEATING - EAT 70°F				
		PSI	FT	TC	SC	kW	HR	EER	HWG Cap	HC	KW	HE	COP	HWG Cap
20	2.8	2.8	6.5	Operation Not Recommended						5.6	0.6	3.6	2.9	
30	1.4	0.8	1.8	11.6	8.1	0.4	12.9	31.6	6.3	0.6	4.4	3.3		
	2.1	1.5	3.5	11.8	8.1	0.4	13.1	32.2	6.6	0.6	4.7	3.4		
	2.8	2.7	6.2	11.9	8.1	0.3	12.8	44.5	6.7	0.6	4.8	3.5		
40	1.4	0.8	1.7	11.3	7.8	0.4	12.5	30.6	7.7	0.7	5.5	3.4		
	2.1	1.5	3.3	11.4	8.0	0.4	12.7	31.1	8.1	0.7	5.8	3.6		
	2.8	2.6	5.9	11.6	8.0	0.4	12.9	31.6	8.2	0.7	5.9	3.6		
50	1.4	0.7	1.6	10.8	7.6	0.5	12.4	23.0	8.8	0.7	6.5	3.9		
	2.1	1.4	3.2	11.1	7.8	0.5	12.7	23.6	9.2	0.7	6.9	4.0		
	2.8	2.4	5.6	11.3	7.8	0.4	12.5	30.6	9.4	0.7	7.1	4.1		
60	1.4	0.7	1.5	10.3	7.4	0.6	12.2	18.1	9.9	0.7	7.6	4.3		
	2.1	1.3	3.0	10.6	7.5	0.5	12.2	22.6	10.3	0.7	8.0	4.5		
	2.8	2.3	5.3	10.8	7.6	0.5	12.4	23.0	10.5	0.7	8.2	4.6		
70	1.4	0.6	1.5	9.7	7.1	0.6	11.6	17.1	10.7	0.7	8.5	4.7		
	2.1	1.2	2.8	10.1	7.3	0.6	12.0	17.8	11.2	0.7	9.0	4.9		
	2.8	2.2	5.0	10.3	7.4	0.6	12.2	18.1	11.4	0.7	9.1	5.0		
80	1.4	0.6	1.4	9.1	6.9	0.7	11.4	13.7	11.7	0.7	9.4	5.1		
	2.1	1.1	2.6	9.5	7.0	0.6	11.4	16.7	12.2	0.7	9.9	5.4		
	2.8	2.0	4.6	9.6	7.1	0.6	11.5	16.9	12.4	0.7	10.1	5.4		
90	1.4	0.6	1.3	8.4	6.6	0.7	10.7	12.6	12.6	0.7	10.3	5.5		
	2.1	1.1	2.5	8.8	6.8	0.7	11.1	13.2	13.1	0.7	10.8	5.7		
	2.8	1.9	4.3	9.0	6.9	0.7	11.3	13.5	13.4	0.7	11.1	5.9		
100	1.4	0.5	1.2	7.7	6.3	0.8	10.3	10.0						
	2.1	1.0	2.3	8.1	6.5	0.8	10.7	10.5						
	2.8	1.7	4.0	8.3	6.6	0.8	11.0	10.9						
110	1.4	0.5	1.1	6.9	6.0	0.9	9.8	7.9	Operation Not Recommended					
	2.1	0.9	2.1	7.4	6.2	0.9	10.3	8.5						
	2.8	1.6	3.7	7.6	6.3	0.8	10.2	9.9						
120	1.4	0.4	1.0	6.1	5.6	1.0	9.4	6.3						
	2.1	0.8	1.9	6.5	5.8	0.9	9.5	7.5						
	2.8	1.5	3.4	6.7	5.9	0.9	9.7	7.7						

- Interpolation is permissible; extrapolation is not.
- All entering air conditions are 80°F (26.6°C) DB and 67°F (19.4°C) WB in cooling, and 70°F (21°C) DB in heating.
- AHRI/ISO certified conditions are 80.6°F (27°C) DB and 66.2°F (19°C) WB in cooling and 68°F (20°C) DB in heating.
- Table does not reflect fan or pump power corrections for AHRI/ISO conditions.
- Performance stated is at the rated power supply; performance may vary as the power supply varies from the rated.
- Operation below 40°F (10.0°C) EWT is based upon 20% methanol antifreeze solution.
- Operation below 60°F (15.5°C) EWT requires optional insulated water/refrigerant circuit.
- See performance correction tables for operating conditions other than those listed above.
- See Performance Data Selection Notes for operation in the shaded areas.
- Regular Cooling operation with an EWT of less than 50°F (10.0°C) is not recommended unless variable water flow is available.
- Regular Heating operation with an EWT of more than 90°F (32°C) is not recommended unless variable water flow is available.
- For quiet operation and long term reliability, it is recommended that systems be designed to avoid continuous operation in the outlined areas.
- Performance capacities shown in thousands of Btu/h
- Hot Water Generator Capacity is based on 90°F entering water and 0.5 GPM/Ton.

Performance Data SE*012 EC Blower Motor

Models:
SE
006-072

350 CFM Rated Airflow

EWT °F	FLOW GPM	WPD		COOLING - EAT 80/67 °F						HEATING - EAT 70°F				
		PSI	FT	TC	SC	kW	HR	EER	HWG Cap	HC	KW	HE	COP	HWG Cap
20	3.5	4.0	9.2	Operation Not Recommended						7.7	0.8	5.1	2.9	
30	1.8	0.6	1.4	12.1	8.0	0.5	13.7	26.9	8.6	0.8	6.0	3.3		
	2.6	2.1	4.8	12.3	8.1	0.5	13.9	27.3	9.0	0.8	6.4	3.5		
	3.5	3.8	8.8	12.7	8.3	0.5	14.2	28.1	9.2	0.8	6.6	3.5		
40	1.8	0.6	1.3	12.7	8.4	0.6	14.6	23.0	10.3	0.9	7.4	3.5		
	2.6	2.0	4.6	12.8	8.4	0.5	14.3	28.4	10.6	0.9	7.7	3.6		
	3.5	3.6	8.3	12.9	8.5	0.5	14.4	28.6	10.8	0.9	7.9	3.7		
50	1.8	0.5	1.1	12.7	8.5	0.6	14.6	23.0	11.4	0.9	8.4	3.9		
	2.6	1.9	4.3	12.8	8.5	0.6	14.7	23.2	11.7	0.9	8.7	4.0		
	3.5	3.4	7.9	12.9	8.6	0.6	14.8	23.4	11.9	0.9	8.9	4.0		
60	1.8	0.4	1.0	12.5	8.4	0.7	14.7	19.2	12.3	0.9	9.3	4.2		
	2.6	1.8	4.0	12.7	8.5	0.7	14.9	19.5	12.6	0.9	9.6	4.3		
	3.5	3.2	7.4	12.8	8.5	0.6	14.7	23.2	12.6	0.9	9.7	4.3		
70	1.8	0.4	0.9	11.9	8.2	0.8	14.5	15.9	12.9	0.9	10.0	4.4		
	2.6	1.6	3.8	12.3	8.3	0.7	14.5	18.9	13.5	1.0	10.2	4.1		
	3.5	3.0	6.9	12.4	8.4	0.7	14.6	19.1	13.6	1.0	10.3	4.1		
80	1.8	0.3	0.7	11.3	8.0	0.9	14.2	13.2	13.7	1.0	10.4	4.2		
	2.6	1.5	3.5	11.6	8.1	0.8	14.2	15.5	13.8	1.0	10.5	4.2		
	3.5	2.8	6.5	11.8	8.1	0.8	14.4	15.7	13.9	1.0	10.6	4.2		
90	1.8	0.3	0.6	10.4	7.7	0.9	13.3	12.2	13.9	1.0	10.6	4.2		
	2.6	1.4	3.3	10.9	7.9	0.9	13.8	12.8	13.9	1.0	10.6	4.2		
	3.5	2.6	6.0	11.2	8.0	0.9	14.1	13.1	13.9	1.0	10.7	4.3		
100	1.8	0.2	0.5	9.5	7.4	1.0	12.8	10.0						
	2.6	1.3	3.0	10.0	7.6	1.0	13.2	10.5						
	3.5	2.4	5.6	10.2	7.6	1.0	13.4	10.7						
110	1.8	0.1	0.3	8.5	7.1	1.1	12.1	8.1	Operation Not Recommended					
	2.6	1.2	2.7	9.0	7.2	1.1	12.6	8.6						
	3.5	2.2	5.1	9.2	7.3	1.1	12.8	8.8						
120	1.8	0.1	0.2	7.5	6.7	1.2	11.4	6.5						
	2.6	1.1	2.5	8.0	6.9	1.2	11.9	6.9						
	3.5	2.0	4.6	8.2	7.0	1.1	12.0	7.4						

- Interpolation is permissible; extrapolation is not.
- All entering air conditions are 80°F (26.6°C) DB and 67°F (19.4°C) WB in cooling, and 70°F (21°C) DB in heating.
- AHRI/ISO certified conditions are 80.6°F (27°C) DB and 66.2°F (19°C) WB in cooling and 68°F (20°C) DB in heating.
- Table does not reflect fan or pump power corrections for AHRI/ISO conditions.
- Performance stated is at the rated power supply; performance may vary as the power supply varies from the rated.
- Operation below 40°F (10.0°C) EWT is based upon 20% methanol antifreeze solution.
- Operation below 60°F (15.5°C) EWT requires optional insulated water/refrigerant circuit.
- See performance correction tables for operating conditions other than those listed above.
- See Performance Data Selection Notes for operation in the shaded areas.
- Regular Cooling operation with an EWT of less than 50°F (10.0°C) is not recommended unless variable water flow is available.
- Regular Heating operation with an EWT of more than 90°F (32°C) is not recommended unless variable water flow is available.
- For quiet operation and long term reliability, it is recommended that systems be designed to avoid continuous operation in the outlined areas.
- Performance capacities shown in thousands of Btu/h
- Hot Water Generator Capacity is based on 90°F entering water and 0.5 GPM/Ton.

Performance Data SE*018 EC Blower Motor

Models:
SE
006-072

600 CFM Rated Airflow

EWT °F	FLOW GPM	WPD		COOLING - EAT 80/67 °F						HEATING - EAT 70°F				
		PSI	FT	TC	SC	kW	HR	EER	HWG Cap	HC	KW	HE	COP	HWG Cap
20	5.5	3.9	9.0	Operation Not Recommended						12.0	1.1	8.1	3.1	
30	2.8	0.7	1.6	20.3	14.9	0.8	22.9	25.7		13.3	1.2	9.3	3.3	
	4.1	2.1	4.9	20.6	15.1	0.8	23.2	27.4		13.8	1.2	9.8	3.4	
	5.5	3.5	8.1	21.2	15.5	0.7	23.7	28.8		14.1	1.2	10.0	3.5	
40	2.8	0.6	1.4	20.7	15.4	0.9	23.6	24.1		15.4	1.2	11.3	3.7	
	4.1	2.0	4.6	21.2	15.6	0.8	24.0	26.1		16.0	1.2	11.9	3.9	
	5.5	3.2	7.4	21.4	15.8	0.8	24.2	27.0		16.4	1.2	12.3	4.0	
50	2.8	0.5	1.0	21.2	16.1	0.9	24.4	22.4		17.6	1.2	13.4	4.2	
	4.1	1.7	3.9	21.4	16.1	0.9	24.5	24.0		18.4	1.2	14.2	4.4	
	5.5	2.5	6.5	21.6	16.2	0.9	24.5	24.9		18.9	1.2	14.7	4.5	
60	2.8	0.3	0.7	20.6	16.2	1.1	24.2	19.6		19.9	1.2	15.7	4.7	
	4.1	1.5	3.5	21.1	16.3	1.0	24.4	21.4		20.9	1.2	16.6	4.9	
	5.5	2.6	6.0	21.2	16.3	1.0	24.5	22.3		21.4	1.3	17.1	5.0	
70	2.8	0.3	0.7	19.6	16.0	1.2	23.6	16.7		22.2	1.3	17.9	5.1	
	4.1	1.4	3.2	20.2	16.2	1.1	23.9	18.4		23.3	1.3	18.9	5.3	
	5.5	2.4	5.5	20.5	16.2	1.1	24.1	19.3		23.9	1.3	19.5	5.4	
80	2.8	0.2	0.5	18.4	15.6	1.3	22.9	14.0		24.5	1.3	20.0	5.5	
	4.1	1.2	2.8	19.1	15.9	1.2	23.3	15.5		25.6	1.3	21.0	5.6	
	5.5	2.2	5.1	19.4	16.0	1.2	23.5	16.3		26.2	1.4	21.5	5.6	
90	2.8	0.2	0.5	17.1	15.2	1.5	22.1	11.6		26.5	1.4	21.8	5.6	
	4.1	1.1	2.5	17.8	15.4	1.4	22.5	12.9		27.6	1.5	22.7	5.6	
	5.5	2.0	4.6	18.2	15.6	1.3	22.7	13.6		28.2	1.5	23.1	5.5	
100	2.8	0.2	0.5	15.8	14.7	1.7	21.5	9.5						
	4.1	1.1	2.5	16.5	15.0	1.6	21.8	10.6						
	5.5	1.9	4.4	16.9	15.1	1.5	22.0	11.2						
110	2.8	0.1	0.2	14.7	14.3	1.9	21.1	7.8		Operation Not Recommended				
	4.1	0.9	2.1	15.3	14.5	1.8	21.3	8.6						
	5.5	1.7	3.9	15.6	14.6	1.7	21.4	9.1						
120	2.8	0.1	0.2	13.8	13.7	2.1	21.1	6.4						
	4.1	0.8	1.8	14.2	14.1	2.0	21.0	7.1						
	5.5	1.6	3.7	14.5	14.2	1.9	21.1	7.5						

- Interpolation is permissible; extrapolation is not.
- All entering air conditions are 80°F (26.6°C) DB and 67°F (19.4°C) WB in cooling, and 70°F (21°C) DB in heating.
- AHRI/ISO certified conditions are 80.6°F (27°C) DB and 66.2°F (19°C) WB in cooling and 68°F (20°C) DB in heating.
- Table does not reflect fan or pump power corrections for AHRI/ISO conditions.
- Performance stated is at the rated power supply; performance may vary as the power supply varies from the rated.
- Operation below 40°F (10.0°C) EWT is based upon 20% methanol antifreeze solution.
- Operation below 60°F (15.5°C) EWT requires optional insulated water/refrigerant circuit.
- See performance correction tables for operating conditions other than those listed above.
- See Performance Data Selection Notes for operation in the shaded areas.
- Regular Cooling operation with an EWT of less than 50°F (10.0°C) is not recommended unless variable water flow is available.
- Regular Heating operation with an EWT of more than 90°F (32°C) is not recommended unless variable water flow is available.
- For quiet operation and long term reliability, it is recommended that systems be designed to avoid continuous operation in the outlined areas.
- Performance capacities shown in thousands of Btu/h
- Hot Water Generator Capacity is based on 90°F entering water and 0.5 GPM/Ton.

Performance Data SE*024 EC Blower Motor (Part Load)

Models:
SE
006-072

700 CFM Rated Airflow

EWT °F	WPD			COOLING - EAT 80/67 °F							WPD			HEATING - EAT 70°F															
	FLOW GPM	PSI	FT	TC	SC	EC					FLOW GPM	PSI	FT	HC	EC														
						kW	HR	EER	LWT	HWG Cap					kW	HE	COP	LWT	HWG Cap										
20	Operation Not Recommended										4.70	0.7	1.5	10.7	1.09	7.0	2.9	17.0	1.2										
30	1.60	0.1	0.2	22.0	15.3	0.60	24.0	36.8	60.0	0.2	2.35	0.1	0.3	12.3	1.09	8.5	3.3	22.7	1.3										
											3.53	0.2	0.5	12.8	1.09	9.1	3.4	24.8	1.4										
											4.70	0.5	1.2	13.1	1.09	9.4	3.5	26.0	1.4										
40	2.34	0.1	0.2	21.3	14.7	0.63	23.4	34.1	60.0	0.2	2.35	0.1	0.3	14.4	1.09	10.7	3.9	30.9	1.4										
											3.53	0.2	0.4	15.1	1.09	11.4	4.1	33.5	1.4										
											4.70	0.4	1.0	15.5	1.09	11.8	4.2	35.0	1.5										
50	2.35	0.1	0.3	21.2	15.1	0.73	23.7	29.0	70.2	0.7	2.35	0.1	0.3	16.5	1.09	12.8	4.5	39.1	1.5										
											3.53	0.2	0.3	17.3	1.09	13.6	4.7	42.3	1.6										
											4.70	0.4	0.9	17.8	1.09	14.1	4.8	44.0	1.6										
60	2.35	0.1	0.3	20.7	15.1	0.86	23.6	24.1	80.1	1.1	2.35	0.1	0.3	18.6	1.09	14.9	5.0	47.3	1.7										
											3.53	0.1	0.3	19.5	1.09	15.8	5.3	51.0	1.7										
											4.70	0.3	0.8	20.0	1.09	16.3	5.4	53.1	1.8										
70	2.35	0.1	0.3	19.8	14.8	1.00	23.2	19.8	89.7	1.6	2.35	0.1	0.3	20.6	1.09	16.9	5.6	55.6	1.8										
											3.53	0.1	0.3	21.6	1.09	17.9	5.8	59.8	1.9										
											4.70	0.3	0.7	22.2	1.09	18.5	6.0	62.1	1.9										
80	2.35	0.1	0.3	18.6	14.4	1.16	22.6	16.1	99.2	2.2	2.35	0.1	0.3	22.6	1.09	18.9	6.1	63.9	2.0										
											3.53	0.1	0.3	23.7	1.09	20.0	6.4	68.7	2.1										
											4.70	0.3	0.7	24.3	1.09	20.5	6.5	71.3	2.1										
85	2.35	0.1	0.3	18.0	14.1	1.24	22.2	14.5	103.9	2.4	2.35	0.1	0.3	23.6	1.09	19.8	6.3	68.1	2.1										
											3.53	0.1	0.3	24.7	1.09	21.0	6.6	73.1	2.1										
											4.70	0.3	0.6	25.3	1.09	21.6	6.8	75.8	2.2										
90	2.35	0.1	0.3	17.2	13.8	1.33	21.8	13.0	108.5	2.9	2.03	0.1	0.2	24.0	1.09	20.3	6.5	70.0	2.2										
																				3.53	0.1	0.3	18.1	14.2	1.22	22.3	14.9	102.6	2.8
																				4.70	0.3	0.6	18.6	14.3	1.16	22.5	16.0	99.6	2.7
100	2.35	0.1	0.3	15.7	13.2	1.51	20.9	10.4	117.8	3.7	1.35	0.10	0.2	24.0	1.09	20.3	6.5	70.0	2.2										
																				3.53	0.1	0.3	16.7	13.6	1.40	21.4	12.0	112.2	3.6
																				4.70	0.2	0.5	17.1	13.8	1.34	21.7	12.8	109.2	3.5
110	2.35	0.1	0.3	14.2	12.6	1.70	20.0	8.3	127.0	4.6	1.01	0.10	0.2	24.0	1.09	20.3	6.5	70.0	2.2										
																				3.53	0.1	0.3	15.1	12.9	1.59	20.5	9.5	121.6	4.4
																				4.70	0.2	0.4	15.6	13.1	1.53	20.8	10.2	118.8	4.3
120	2.35	0.1	0.3	12.6	11.9	1.91	19.1	6.6	136.2	5.6	0.81	0.10	0.2	24.0	1.09	20.3	6.5	70.0	2.2										
																				3.53	0.1	0.3	13.4	12.3	1.79	19.6	7.5	131.1	5.4
																				4.70	0.1	0.3	13.9	12.5	1.73	19.8	8.0	128.4	5.3

- Interpolation is permissible; extrapolation is not.
- All entering air conditions are 80°F (26.6°C) DB and 67°F (19.4°C) WB in cooling, and 70°F (21°C) DB in heating.
- AHRI/ISO certified conditions are 80.6°F (27°C) DB and 66.2°F (19°C) WB in cooling and 68°F (20°C) DB in heating.
- Table does not reflect fan or pump power corrections for AHRI/ISO conditions.
- All performance is based upon the lower voltage of dual voltage rated units.
- Performance stated is at the rated power supply; performance may vary as the power supply varies from the rated.
- Operation below 40°F (10.0°C) EWT is based upon 20% methanol antifreeze solution.
- Operation below 60°F (15.5°C) EWT requires optional insulated water/refrigerant circuit.
- See performance correction tables for operating conditions other than those listed above.
- See Performance Data Selection Notes for operation in the shaded areas.
- Regular Cooling operation with an EWT of less than 50°F (10.0°C) is not recommended unless variable water flow is available.
- Regular Heating operation with an EWT of more than 90°F (32°C) is not recommended unless variable water flow is available.
- For quiet operation and long term reliability, it is recommended that systems be designed to avoid continuous operation in the outlined areas.
- Performance capacities shown in thousands of Btuh
- Hot Water Generator Capacity is based on 90°F entering water and 0.5 GPM/Ton.

ClimateMaster works continually to improve its products. As a result, the design and specifications of each product at the time of order may be changed without notice and may not be as described herein. Please contact ClimateMaster's Customer Service Department at 1-800-299-9747 for specific information on the current design and specifications. Statements and other information contained herein are not express warranties and do not form the basis of any bargain between the parties, but are merely ClimateMaster's opinion or commendation of its products. The latest version of this document is available at www.climatemaster.com. Engineered and assembled in the USA. © ClimateMaster, Inc. All Rights Reserved 2024

Performance Data SE*024 EC Blower Motor (Full Load)

Models:
SE
006-072

800 CFM Rated Airflow

EWT °F	WPD			COOLING - EAT 80/67 °F							WPD			HEATING - EAT 70°F					
	FLOW GPM	PSI	FT	TC	SC	EC					FLOW GPM	PSI	FT	HC	EC				
						kW	HR	EER	LWT	HWG Cap					kW	HE	COP	LWT	HWG Cap
20	Operation Not Recommended										6.00	1.2	2.7	16.2	1.47	11.1	3.2	16.3	1.9
	Operation Not Recommended										3.00	0.1	0.3	17.9	1.49	12.8	3.5	21.5	2.0
30	2.14	0.10	0.20	28.5	19.1	1.06	32.1	27.0	60.0	1.4	4.50	0.5	1.2	18.7	1.50	13.6	3.7	24.0	2.2
	Operation Not Recommended										6.00	1.0	2.3	19.2	1.50	14.0	3.7	25.3	2.5
40	3.15	0.10	0.30	27.8	18.5	1.07	31.5	26.0	60.0	1.4	3.00	0.1	0.3	20.6	1.52	15.4	4.0	29.7	2.2
	Operation Not Recommended										4.50	0.4	1.0	21.6	1.53	16.3	4.1	32.7	2.5
	Operation Not Recommended										6.00	0.9	2.1	22.1	1.53	16.8	4.2	34.4	2.7
50	3.00	0.1	0.3	27.8	18.9	1.21	32.0	23.0	71.3	1.7	3.00	0.1	0.3	23.2	1.55	18.0	4.4	38.0	2.5
	4.50	0.4	0.8	27.9	18.7	1.12	31.7	25.0	64.1	1.6	4.50	0.4	0.8	24.3	1.56	19.0	4.6	41.6	2.7
	6.00	0.8	1.9	27.9	18.6	1.07	31.5	25.9	60.5	1.4	6.00	0.8	1.9	24.9	1.57	19.6	4.6	43.5	3.0
60	3.00	0.1	0.3	27.3	18.8	1.35	31.9	20.2	81.3	2.1	3.00	0.1	0.3	25.8	1.59	20.4	4.8	46.4	2.8
	4.50	0.3	0.7	27.7	18.9	1.25	32.0	22.2	74.2	1.9	4.50	0.3	0.7	27.1	1.61	21.6	4.9	50.4	3.1
	6.00	0.8	1.7	27.9	18.9	1.20	31.9	23.2	70.6	1.8	6.00	0.8	1.7	27.8	1.62	22.2	5.0	52.6	3.3
70	3.00	0.1	0.3	26.3	18.4	1.51	31.5	17.4	91.0	2.7	3.00	0.1	0.3	28.4	1.63	22.9	5.1	54.8	3.1
	4.50	0.3	0.6	27.0	18.7	1.40	31.8	19.4	84.1	2.4	4.50	0.3	0.6	29.8	1.65	24.2	5.3	59.3	3.5
	6.00	0.7	1.6	27.3	18.8	1.34	31.9	20.4	80.6	2.2	6.00	0.7	1.6	30.6	1.67	24.9	5.4	61.7	3.8
80	3.00	0.1	0.3	25.1	17.9	1.70	30.9	14.8	100.6	3.4	3.00	0.1	0.3	31.0	1.68	25.3	5.4	63.2	3.5
	4.50	0.2	0.5	26.0	18.3	1.57	31.4	16.6	93.9	3.1	4.50	0.2	0.5	32.5	1.71	26.7	5.6	68.1	3.9
	6.00	0.7	1.6	26.4	18.5	1.51	31.5	17.5	90.5	2.8	6.00	0.7	1.6	33.4	1.73	27.5	5.7	70.8	4.3
85	3.00	0.1	0.3	24.4	17.6	1.80	30.6	13.6	105.4	3.5	3.00	0.1	0.3	32.3	1.70	26.5	5.6	67.4	3.7
	4.50	0.2	0.5	25.4	18.0	1.66	31.0	15.3	98.8	3.3	4.50	0.2	0.5	33.9	1.74	28.0	5.7	72.6	4.1
	6.00	0.7	1.5	25.8	18.2	1.60	31.3	16.2	95.4	3.2	6.00	0.7	1.5	34.8	1.76	28.8	5.8	75.4	4.4
90	3.00	0.1	0.3	23.7	17.2	1.91	30.2	12.4	110.1	4.4	2.72	0.1	0.2	33.1	1.72	27.2	5.6	70.0	4.4
	4.50	0.2	0.5	24.7	17.7	1.76	30.7	14.0	103.6	4.0									
	6.00	0.6	1.5	25.2	17.9	1.69	30.9	14.9	100.3	3.6									
100	3.00	0.1	0.3	22.1	16.6	2.15	29.5	10.3	119.6	5.4	1.82	0.1	0.2	33.1	1.72	27.2	5.6	70.0	4.4
	4.50	0.2	0.4	23.2	17.0	1.99	30.0	11.7	113.3	5.0									
	6.00	0.6	1.4	23.7	17.2	1.91	30.2	12.4	110.1	4.1									
110	3.00	0.1	0.3	20.5	15.9	2.43	28.8	8.4	129.2	6.7	1.36	0.1	0.2	33.1	1.72	27.2	5.6	70.0	4.4
	4.50	0.2	0.4	21.6	16.3	2.25	29.2	9.6	123.0	6.2									
	6.00	0.6	1.3	22.1	16.6	2.16	29.5	10.2	119.8	5.1									
120	3.00	0.1	0.3	18.9	15.4	2.75	28.3	6.9	138.8	8.2	1.09	0.1	0.2	33.1	1.72	27.2	5.6	70.0	4.4
	4.50	0.1	0.3	19.9	15.7	2.54	28.6	7.8	132.7	7.5									
	6.00	0.5	1.1	20.4	15.9	2.45	28.8	8.4	129.6	6.2									

- Interpolation is permissible; extrapolation is not.
- All entering air conditions are 80°F (26.6°C) DB and 67°F (19.4°C) WB in cooling, and 70°F (21°C) DB in heating.
- AHRI/ISO certified conditions are 80.6°F (27°C) DB and 66.2°F (19°C) WB in cooling and 68°F (20°C) DB in heating.
- Table does not reflect fan or pump power corrections for AHRI/ISO conditions.
- All performance is based upon the lower voltage of dual voltage rated units.
- Performance stated is at the rated power supply; performance may vary as the power supply varies from the rated.
- Operation below 40°F (10.0°C) EWT is based upon 20% methanol antifreeze solution.
- Operation below 60°F (15.5°C) EWT requires optional insulated water/refrigerant circuit.
- See performance correction tables for operating conditions other than those listed above.
- See Performance Data Selection Notes for operation in the shaded areas.
- Regular Cooling operation with an EWT of less than 50°F (10.0°C) is not recommended unless variable water flow is available.
- Regular Heating operation with an EWT of more than 90°F (32°C) is not recommended unless variable water flow is available.
- For quiet operation and long term reliability, it is recommended that systems be designed to avoid continuous operation in the outlined areas.
- Performance capacities shown in thousands of Btuh
- Hot Water Generator Capacity is based on 90°F entering water and 0.5 GPM/Ton.

ClimateMaster works continually to improve its products. As a result, the design and specifications of each product at the time of order may be changed without notice and may not be as described herein. Please contact ClimateMaster's Customer Service Department at 1-800-299-9747 for specific information on the current design and specifications. Statements and other information contained herein are not express warranties and do not form the basis of any bargain between the parties, but are merely ClimateMaster's opinion or commendation of its products. The latest version of this document is available at www.climatemaster.com. Engineered and assembled in the USA. © ClimateMaster, Inc. All Rights Reserved 2024

Performance Data SE*036 EC Blower Motor (Part Load)

Models:
SE
006-072

1100 CFM Rated Airflow

EWT °F	WPD			COOLING - EAT 80/67 °F							WPD			HEATING - EAT 70°F															
	FLOW GPM	PSI	FT	TC	SC	EC					FLOW GPM	PSI	FT	HC	EC														
						kW	HR	EER	LWT	HWG Cap					kW	HE	COP	LWT	HWG Cap										
20	Operation Not Recommended										6.70	2.2	5.0	16.7	1.47	11.7	3.3	16.5	1.6										
30	2.42	0.2	0.4	33.4	21.9	0.87	36.3	38.3	60.0	1.1	3.35	0.6	1.4	18.9	1.49	13.8	3.7	21.7	1.7										
											5.03	1.2	2.7	19.9	1.50	14.8	3.9	24.1	1.7										
											6.70	2.0	4.5	20.4	1.50	15.3	4.0	25.4	1.8										
40	3.49	0.6	1.3	31.8	20.8	0.91	34.9	35.0	60.0	1.1	3.35	0.5	1.2	22.1	1.52	17.0	4.3	29.9	1.8										
											5.03	1.1	2.5	23.3	1.52	18.1	4.5	32.8	1.8										
											6.70	1.8	4.1	23.9	1.53	18.7	4.6	34.4	1.9										
50	3.35	0.5	1.1	31.8	21.4	1.05	35.4	30.3	71.2	1.3	3.35	0.5	1.1	25.2	1.54	20.0	4.8	38.1	1.9										
											5.03	1.0	2.3	26.5	1.55	21.2	5.0	41.6	1.9										
											6.70	1.6	3.8	31.8	20.9	0.91	34.9	34.9	60.4	1.2	6.70	1.6	3.8	27.2	1.56	21.9	5.1	43.5	2.0
60	3.35	0.5	1.1	30.9	21.3	1.21	35.1	25.6	80.9	1.4	3.35	0.5	1.1	28.2	1.57	22.9	5.3	46.3	2.0										
											5.03	0.9	2.1	31.7	21.5	1.09	35.4	28.9	74.1	1.4	5.03	0.9	2.1	29.6	1.58	24.3	5.5	50.4	2.1
											6.70	1.5	3.6	31.9	21.4	1.04	35.4	30.6	70.6	1.3	6.70	1.5	3.6	30.4	1.59	25.0	5.6	52.5	2.2
70	3.35	0.5	1.0	29.5	20.8	1.38	34.2	21.3	90.4	1.8	3.35	0.5	1.0	31.1	1.59	25.7	5.7	54.6	2.3										
											5.03	0.9	2.1	30.5	21.2	1.26	34.8	24.3	83.9	1.7	5.03	0.9	2.1	32.7	1.61	27.2	6.0	59.2	2.3
											6.70	1.5	3.4	31.0	21.3	1.20	35.1	25.9	80.5	1.7	6.70	1.5	3.4	33.6	1.61	28.1	6.1	61.6	2.4
80	3.35	0.4	1.0	27.7	20.1	1.58	33.1	17.5	99.8	2.4	3.35	0.4	1.0	34.0	1.62	28.5	6.2	63.0	2.5										
											5.03	0.9	2.0	28.9	20.6	1.45	33.9	20.0	93.5	2.3	5.03	0.9	2.0	35.7	1.63	30.2	6.4	68.0	2.6
											6.70	1.4	3.3	29.5	20.8	1.38	34.2	21.4	90.2	2.3	6.70	1.4	3.3	36.7	1.64	31.1	6.5	70.7	2.7
85	3.35	0.4	1.0	26.8	19.7	1.69	32.5	15.9	104.4	2.9	3.35	0.4	1.0	35.5	1.63	29.9	6.4	67.2	2.6										
											5.03	0.9	2.0	28.0	20.2	1.55	33.3	18.1	98.2	2.8	5.03	0.9	2.0	37.3	1.65	31.6	6.6	72.4	2.7
											6.70	1.4	3.3	28.6	20.5	1.48	33.7	19.4	95.1	2.6	6.70	1.4	3.3	38.2	1.66	32.6	6.8	75.3	2.8
90	3.35	0.4	1.0	25.8	19.2	1.80	31.9	14.4	109.1	3.3	3.1	0.1	0.2	36.4	1.64	30.8	6.5	70.0	2.8										
																				5.03	0.9	2.0	27.0	19.8	1.65	32.7	16.4	103.0	3.2
																				6.70	1.4	3.2	27.7	20.1	1.58	33.1	17.5	99.9	3.1
100	3.35	0.4	1.0	24.0	18.5	2.04	30.9	11.8	118.5	4.4	2.1	0.1	0.2	36.4	1.6	30.8	6.5	70.0	2.8										
																				5.03	0.8	1.9	25.1	19.0	1.88	31.5	13.3	112.5	4.3
																				6.70	1.4	3.2	25.7	19.2	1.81	31.9	14.2	109.5	4.1
110	3.35	0.4	1.0	22.4	18.0	2.30	30.3	9.7	128.1	5.7	1.5	0.1	0.2	36.4	1.6	30.8	6.5	70.0	2.8										
																				5.03	0.8	1.9	23.3	18.3	2.14	30.6	10.9	122.2	5.6
																				6.70	1.3	3.1	23.8	18.5	2.06	30.9	11.6	119.2	5.4
120	3.35	0.4	1.0	21.4	18.1	2.60	30.3	8.2	138.1	7.3	1.2	0.1	0.2	36.4	1.6	30.8	6.5	70.0	2.8										
																				5.03	0.8	1.8	22.0	18.0	2.42	30.2	9.1	132.0	7.1
																				6.70	1.3	3.0	22.3	18.0	2.33	30.3	9.6	129.0	6.9

- Interpolation is permissible; extrapolation is not.
- All entering air conditions are 80°F (26.6°C) DB and 67°F (19.4°C) WB in cooling, and 70°F (21°C) DB in heating.
- AHRI/ISO certified conditions are 80.6°F (27°C) DB and 66.2°F (19°C) WB in cooling and 68°F (20°C) DB in heating.
- Table does not reflect fan or pump power corrections for AHRI/ISO conditions.
- All performance is based upon the lower voltage of dual voltage rated units.
- Performance stated is at the rated power supply; performance may vary as the power supply varies from the rated.
- Operation below 40°F (10.0°C) EWT is based upon 20% methanol antifreeze solution.
- Operation below 60°F (15.5°C) EWT requires optional insulated water/refrigerant circuit.
- See performance correction tables for operating conditions other than those listed above.
- See Performance Data Selection Notes for operation in the shaded areas.
- Regular Cooling operation with an EWT of less than 50°F (10.0°C) is not recommended unless variable water flow is available.
- Regular Heating operation with an EWT of more than 90°F (32°C) is not recommended unless variable water flow is available.
- For quiet operation and long term reliability, it is recommended that systems be designed to avoid continuous operation in the outlined areas.
- Performance capacities shown in thousands of Btuh
- Hot Water Generator Capacity is based on 90°F entering water and 0.5 GPM/Ton.

ClimateMaster works continually to improve its products. As a result, the design and specifications of each product at the time of order may be changed without notice and may not be as described herein. Please contact ClimateMaster's Customer Service Department at 1-800-299-9747 for specific information on the current design and specifications. Statements and other information contained herein are not express warranties and do not form the basis of any bargain between the parties, but are merely ClimateMaster's opinion or commendation of its products. The latest version of this document is available at www.climatemaster.com. Engineered and assembled in the USA. © ClimateMaster, Inc. All Rights Reserved 2024

Performance Data SE*036 EC Blower Motor (Full Load)

Models:
SE
006-072

1200 CFM Rated Airflow

EWT °F	WPD			COOLING - EAT 80/67 °F							WPD			HEATING - EAT 70°F					
	FLOW GPM	PSI	FT	TC	SC	EC					FLOW GPM	PSI	FT	HC	EC				
						kW	HR	EER	LWT	HWG Cap					kW	HE	COP	LWT	HWG Cap
20	Operation Not Recommended										9.00	3.7	8.5	23.9	1.95	17.3	3.6	16.2	2.0
30	3.30	0.4	0.9	44.2	27.8	1.55	49.5	28.5	60.0	1.1	4.50	1.0	2.3	26.7	2.00	19.9	3.9	21.2	2.5
											6.75	2.0	4.7	28.1	2.02	21.2	4.1	23.7	2.7
											9.00	3.2	7.5	28.8	2.04	21.9	4.1	25.1	3.0
40	4.74	1.0	2.2	42.1	26.5	1.56	47.4	27.0	60.0	1.1	4.50	0.9	2.1	31.1	2.08	24.0	4.4	29.4	3.0
											6.75	1.8	4.2	32.7	2.11	25.5	4.5	32.5	3.3
											9.00	2.9	6.8	33.5	2.13	26.3	4.6	34.2	3.6
50	4.50	0.8	1.9	42.5	27.3	1.75	48.5	24.4	71.6	1.6	4.50	0.8	1.9	35.3	2.17	27.9	4.8	37.6	3.5
											6.75	1.6	3.8	42.5	2.21	29.6	4.9	41.2	3.8
											9.00	2.7	6.2	42.2	2.24	30.5	5.0	43.2	4.2
60	4.50	0.8	1.8	41.6	27.2	1.93	48.2	21.6	81.4	2.2	4.50	0.8	1.8	39.4	2.27	31.7	5.1	45.9	4.0
											6.75	1.5	3.5	42.4	2.32	33.5	5.2	50.1	4.4
											9.00	2.5	5.9	42.6	2.35	34.5	5.3	52.3	4.8
70	4.50	0.7	1.7	39.9	26.5	2.12	47.1	18.8	90.9	3.0	4.50	0.7	1.7	43.5	2.37	35.4	5.4	54.3	4.5
											6.75	1.5	3.4	41.2	2.43	37.4	5.5	58.9	5.0
											9.00	2.4	5.6	41.7	2.47	38.4	5.6	61.5	5.4
80	4.50	0.7	1.7	37.7	25.5	2.34	45.7	16.1	100.3	3.9	4.50	0.7	1.7	47.4	2.48	38.9	5.6	62.7	5.0
											6.75	1.4	3.3	39.2	2.56	41.1	5.7	67.8	5.5
											9.00	2.4	5.5	40.0	2.60	42.2	5.8	70.6	6.0
85	4.50	0.7	1.7	36.5	24.9	2.46	44.9	14.9	105.0	4.4	4.50	0.7	1.7	49.4	2.54	40.7	5.7	66.9	5.3
											6.75	1.4	3.3	38.1	2.62	42.9	5.8	72.3	5.8
											9.00	2.4	5.4	38.9	2.66	44.1	5.9	75.2	6.3
90	4.50	0.7	1.7	35.4	24.3	2.59	44.2	13.7	109.6	5.1	4.20	0.1	0.2	50.8	2.59	42.0	5.8	70.0	6.3
											6.75	1.4	3.3	36.9	2.59	42.0	5.8	70.0	6.3
											9.00	2.3	5.4	37.8	2.59	42.0	5.8	70.0	6.3
100	4.50	0.7	1.6	33.1	23.2	2.87	42.9	11.5	119.1	6.4	2.80	0.1	0.2	50.8	2.59	42.0	5.8	70.0	6.3
											6.75	1.4	3.2	34.5	2.59	42.0	5.8	70.0	6.3
											9.00	2.3	5.3	35.3	2.59	42.0	5.8	70.0	6.3
110	4.50	0.7	1.6	31.2	22.3	3.19	42.0	9.8	128.7	7.9	2.10	0.1	0.2	50.8	2.59	42.0	5.8	70.0	6.3
											6.75	1.4	3.2	32.3	2.59	42.0	5.8	70.0	6.3
											9.00	2.2	5.1	33.0	2.59	42.0	5.8	70.0	6.3
120	4.50	0.7	1.5	29.9	22.0	3.57	42.1	8.4	138.7	9.7	1.68	0.1	0.2	50.8	2.59	42.0	5.8	70.0	6.3
											6.75	1.3	3.0	30.6	2.59	42.0	5.8	70.0	6.3
											9.00	2.1	4.9	31.1	2.59	42.0	5.8	70.0	6.3

- Interpolation is permissible; extrapolation is not.
- All entering air conditions are 80°F (26.6°C) DB and 67°F (19.4°C) WB in cooling, and 70°F (21°C) DB in heating.
- AHRI/ISO certified conditions are 80.6°F (27°C) DB and 66.2°F (19°C) WB in cooling and 68°F (20°C) DB in heating.
- Table does not reflect fan or pump power corrections for AHRI/ISO conditions.
- All performance is based upon the lower voltage of dual voltage rated units.
- Performance stated is at the rated power supply; performance may vary as the power supply varies from the rated.
- Operation below 40°F (10.0°C) EWT is based upon 20% methanol antifreeze solution.
- Operation below 60°F (15.5°C) EWT requires optional insulated water/refrigerant circuit.
- See performance correction tables for operating conditions other than those listed above.
- See Performance Data Selection Notes for operation in the shaded areas.
- Regular Cooling operation with an EWT of less than 50°F (10.0°C) is not recommended unless variable water flow is available.
- Regular Heating operation with an EWT of more than 90°F (32°C) is not recommended unless variable water flow is available.
- For quiet operation and long term reliability, it is recommended that systems be designed to avoid continuous operation in the outlined areas.
- Performance capacities shown in thousands of Btuh
- Hot Water Generator Capacity is based on 90°F entering water and 0.5 GPM/Ton.

ClimateMaster works continually to improve its products. As a result, the design and specifications of each product at the time of order may be changed without notice and may not be as described herein. Please contact ClimateMaster's Customer Service Department at 1-800-299-9747 for specific information on the current design and specifications. Statements and other information contained herein are not express warranties and do not form the basis of any bargain between the parties, but are merely ClimateMaster's opinion or commendation of its products. The latest version of this document is available at www.climatemaster.com. Engineered and assembled in the USA. © ClimateMaster, Inc. All Rights Reserved 2024

Performance Data SE*048 EC Blower Motor (Part Load)

Models:
SE
006-072

1500 CFM Rated Airflow

EWT °F	WPD			COOLING - EAT 80/67 °F							WPD			HEATING - EAT 70°F															
	FLOW GPM	PSI	FT	TC	SC	EC					FLOW GPM	PSI	FT	HC	EC														
						kW	HR	EER	LWT	HWG Cap					kW	HE	COP	LWT	HWG Cap										
20	Operation Not Recommended										9.20	2.1	4.9	23.1	2.16	15.7	3.1	16.6	2.4										
30	3.16	0.3	0.6	43.2	30.4	1.22	47.4	35.5	60.0	1.3	4.60	0.7	1.6	25.4	2.15	18.1	3.5	22.1	2.6										
											6.90	1.3	2.9	26.4	2.15	19.1	3.6	24.5	2.7										
											9.20	2.0	4.6	27.0	2.15	19.6	3.7	25.7	2.8										
40	4.59	0.6	1.4	41.6	29.0	1.27	45.9	32.8	60.0	1.3	4.60	0.6	1.5	29.2	2.15	21.9	4.0	30.5	2.9										
											6.90	1.2	2.7	30.6	2.16	23.2	4.1	33.3	3.0										
											9.20	1.9	4.3	31.3	2.16	23.9	4.2	34.8	3.0										
50	4.60	0.6	1.4	41.5	29.8	1.46	46.4	28.5	70.2	1.5	4.60	0.6	1.4	33.3	2.17	25.9	4.5	38.8	3.1										
											6.90	1.1	2.6	41.6	29.3	1.33	46.2	31.4	63.4	1.5	6.90	1.1	2.6	34.9	2.17	27.5	4.7	42.0	3.2
											9.20	1.8	4.1	41.5	28.9	1.27	45.8	32.8	60.0	1.4	9.20	1.8	4.1	35.9	2.18	28.4	4.8	43.8	3.3
60	4.60	0.6	1.4	40.4	29.8	1.68	46.1	24.0	80.0	2.0	4.60	0.6	1.4	37.5	2.19	30.0	5.0	46.9	3.4										
											6.90	1.1	2.5	41.2	29.9	1.53	46.4	27.0	73.5	1.9	6.90	1.1	2.5	39.5	2.20	32.0	5.3	50.7	3.5
											9.20	1.7	3.9	41.5	29.8	1.46	46.4	28.5	70.1	1.8	9.20	1.7	3.9	40.6	2.20	33.0	5.4	52.8	3.7
70	4.60	0.6	1.3	38.5	29.0	1.93	45.1	20.0	89.6	2.5	4.60	0.6	1.3	41.8	2.21	34.2	5.5	55.1	3.8										
											6.90	1.1	2.4	39.8	29.6	1.76	45.8	22.6	83.3	2.5	6.90	1.1	2.4	44.0	2.22	36.5	5.8	59.4	3.9
											9.20	1.7	3.9	40.4	29.8	1.68	46.1	24.0	80.0	2.4	9.20	1.7	3.9	45.3	2.22	37.7	6.0	61.8	4.0
80	4.60	0.6	1.3	36.1	27.8	2.20	43.6	16.4	99.0	3.3	4.60	0.6	1.3	46.0	2.23	38.4	6.1	63.3	4.2										
											6.90	1.0	2.4	37.7	28.6	2.02	44.6	18.6	92.9	3.2	6.90	1.0	2.4	48.5	2.24	40.9	6.4	68.2	4.3
											9.20	1.7	3.8	38.5	29.0	1.93	45.1	19.9	89.8	3.1	9.20	1.7	3.8	49.9	2.24	42.2	6.5	70.8	4.4
85	4.60	0.6	1.3	34.8	27.2	2.35	42.8	14.8	103.6	4.0	4.60	0.6	1.3	48.1	2.24	40.5	6.3	67.4	4.3										
											6.90	1.0	2.4	36.5	28.0	2.16	43.8	16.8	97.7	3.8	6.90	1.0	2.4	50.7	2.25	43.0	6.6	72.5	4.4
											9.20	1.6	3.8	37.3	28.4	2.07	44.3	18.0	94.6	3.5	9.20	1.6	3.8	52.1	2.25	44.4	6.8	75.3	4.6
90	4.60	0.6	1.3	33.3	26.4	2.50	41.9	13.3	108.2	4.2	4.18	0.1	0.2	49.5	2.24	41.8	6.5	70.0	4.6										
																				6.90	1.0	2.4	35.1	27.3	2.31	43.0	15.2	102.5	4.1
																				9.20	1.6	3.8	36.0	27.8	2.22	43.5	16.2	99.5	4.0
100	4.60	0.6	1.4	30.4	25.0	2.82	40.0	10.8	117.4	5.3	2.79	0.10	0.23	49.5	2.24	41.8	6.47	70.0	4.6										
																				6.90	1.0	2.4	32.2	25.8	2.63	41.1	12.2	111.9	5.2
																				9.20	1.6	3.7	33.1	26.3	2.53	41.7	13.1	109.1	5.0
110	4.60	0.6	1.3	27.3	23.5	3.16	38.1	8.6	126.6	6.6	2.09	0.10	0.23	49.5	2.24	41.8	6.47	70.0	4.6										
																				6.90	1.0	2.4	29.0	24.3	2.97	39.2	9.8	121.3	6.4
																				9.20	1.6	3.7	29.9	24.8	2.87	39.7	10.4	118.6	6.2
120	4.60	0.6	1.3	24.3	22.2	3.53	36.3	6.9	135.8	8.0	1.67	0.10	0.23	49.5	2.24	41.8	6.47	70.0	4.6										
																				6.90	1.0	2.3	25.9	22.9	3.33	37.3	7.8	130.8	7.8
																				9.20	1.6	3.6	26.7	23.3	3.23	37.8	8.3	128.2	7.5

- Interpolation is permissible; extrapolation is not.
- All entering air conditions are 80°F (26.6°C) DB and 67°F (19.4°C) WB in cooling, and 70°F (21°C) DB in heating.
- AHRI/ISO certified conditions are 80.6°F (27°C) DB and 66.2°F (19°C) WB in cooling and 68°F (20°C) DB in heating.
- Table does not reflect fan or pump power corrections for AHRI/ISO conditions.
- All performance is based upon the lower voltage of dual voltage rated units.
- Performance stated is at the rated power supply; performance may vary as the power supply varies from the rated.
- Operation below 40°F (10.0°C) EWT is based upon 20% methanol antifreeze solution.
- Operation below 60°F (15.5°C) EWT requires optional insulated water/refrigerant circuit.
- See performance correction tables for operating conditions other than those listed above.
- See Performance Data Selection Notes for operation in the shaded areas.
- Regular Cooling operation with an EWT of less than 50°F (10.0°C) is not recommended unless variable water flow is available.
- Regular Heating operation with an EWT of more than 90°F (32°C) is not recommended unless variable water flow is available.
- For quiet operation and long term reliability, it is recommended that systems be designed to avoid continuous operation in the outlined areas.
- Performance capacities shown in thousands of Btuh
- Hot Water Generator Capacity is based on 90°F entering water and 0.5 GPM/Ton.

ClimateMaster works continually to improve its products. As a result, the design and specifications of each product at the time of order may be changed without notice and may not be as described herein. Please contact ClimateMaster's Customer Service Department at 1-800-299-9747 for specific information on the current design and specifications. Statements and other information contained herein are not express warranties and do not form the basis of any bargain between the parties, but are merely ClimateMaster's opinion or commendation of its products. The latest version of this document is available at www.climatemaster.com. Engineered and assembled in the USA. © ClimateMaster, Inc. All Rights Reserved 2024

Performance Data SE*048 EC Blower Motor (Full Load)

Models:
SE
006-072

1600 CFM Rated Airflow

EWT °F	WPD			COOLING - EAT 80/67 °F							WPD			HEATING - EAT 70°F					
	FLOW GPM	PSI	FT	TC	SC	EC					FLOW GPM	PSI	FT	HC	EC				
						kW	HR	EER	LWT	HWG Cap					kW	HE	COP	LWT	HWG Cap
20	Operation Not Recommended										12.00	3.4	7.8	34.0	2.95	23.9	3.4	16.0	3.2
30	4.35	0.4	0.9	57.7	37.5	2.21	65.2	26.1	60.0	1.2	6.00	1.0	2.4	36.5	2.98	26.3	3.6	21.2	3.6
											9.00	1.9	4.5	37.9	3.00	27.6	3.7	23.9	3.9
40	6.31	1.0	2.3	55.5	36.2	2.22	63.1	25.0	60.0	1.2	12.00	3.1	7.2	38.7	3.01	28.4	3.8	25.3	4.3
											6.00	0.9	2.2	41.3	3.05	30.9	4.0	29.7	4.0
											9.00	1.8	4.2	43.2	3.08	32.6	4.1	32.7	4.3
50	6.00	0.9	2.1	55.7	37.2	2.47	64.2	22.6	71.4	2.3	12.00	2.9	6.7	44.2	3.11	33.6	4.2	34.4	4.5
											6.00	0.9	2.1	46.6	3.15	35.9	4.3	38.0	4.4
											9.00	1.7	3.9	49.0	3.20	38.1	4.5	41.5	4.8
60	6.00	0.9	2.0	54.5	37.1	2.71	63.7	20.1	81.2	3.1	12.00	2.8	6.4	50.3	3.23	39.3	4.6	43.5	5.0
											6.00	0.9	2.0	52.3	3.28	41.1	4.7	46.3	4.8
											9.00	1.6	3.8	55.5	3.73	43.7	4.8	50.3	5.3
70	6.00	0.9	2.0	52.3	36.2	2.98	62.4	17.6	90.8	4.0	12.00	2.7	6.2	56.6	3.38	45.1	4.9	52.5	5.7
											6.00	0.9	2.0	58.1	3.41	46.4	5.0	54.5	5.3
											9.00	1.6	3.7	61.2	3.49	49.3	5.1	59.0	5.9
80	6.00	0.8	2.0	49.4	34.8	3.28	60.6	15.1	100.2	5.0	12.00	2.6	6.1	62.9	3.53	50.9	5.2	61.5	6.4
											6.00	0.8	2.0	63.8	3.55	51.6	5.3	62.8	5.9
											9.00	1.6	3.7	67.1	3.63	54.7	5.4	67.8	6.5
85	6.00	0.8	2.0	47.9	34.0	3.44	59.6	13.9	104.9	5.6	12.00	2.6	6.0	68.8	3.68	56.3	5.5	70.6	7.1
											6.00	0.8	2.0	66.5	3.62	54.2	5.4	66.9	6.2
											9.00	1.6	3.7	69.8	3.70	57.2	5.5	72.3	6.8
90	6.00	0.8	2.0	46.3	33.2	3.62	58.6	12.8	109.5	6.2	12.00	2.6	5.9	71.6	3.74	58.8	5.6	75.2	7.4
											6.00	0.8	2.0	68.5	3.67	56.0	5.5	70.0	7.4
											9.00	1.6	3.7	71.6	3.74	58.8	5.6	75.2	7.4
100	6.00	0.8	2.0	43.1	31.4	4.00	56.7	10.8	118.9	7.5	12.00	2.5	5.9	74.4	3.84	60.4	5.7	78.4	7.9
											6.00	0.8	2.0	74.4	3.84	60.4	5.7	78.4	7.9
											9.00	1.6	3.6	77.5	3.92	62.5	5.8	81.5	8.0
110	6.00	0.8	1.9	40.0	29.7	4.45	55.2	9.0	128.4	8.9	12.00	2.5	5.8	77.5	3.92	62.5	5.8	81.5	8.0
											6.00	0.8	1.9	77.5	3.92	62.5	5.8	81.5	8.0
											9.00	1.6	3.6	80.6	4.00	64.6	5.9	84.6	8.1
120	6.00	0.8	1.9	37.3	28.4	4.96	54.2	7.5	138.1	10.5	12.00	2.5	5.7	79.6	4.00	64.6	5.9	84.6	8.1
											6.00	0.8	1.9	79.6	4.00	64.6	5.9	84.6	8.1
											9.00	1.5	3.5	82.7	4.08	66.7	6.0	87.7	8.2

- Interpolation is permissible; extrapolation is not.
- All entering air conditions are 80°F (26.6°C) DB and 67°F (19.4°C) WB in cooling, and 70°F (21°C) DB in heating.
- AHRI/ISO certified conditions are 80.6°F (27°C) DB and 66.2°F (19°C) WB in cooling and 68°F (20°C) DB in heating.
- Table does not reflect fan or pump power corrections for AHRI/ISO conditions.
- All performance is based upon the lower voltage of dual voltage rated units.
- Performance stated is at the rated power supply; performance may vary as the power supply varies from the rated.
- Operation below 40°F (10.0°C) EWT is based upon 20% methanol antifreeze solution.
- Operation below 60°F (15.5°C) EWT requires optional insulated water/refrigerant circuit.
- See performance correction tables for operating conditions other than those listed above.
- See Performance Data Selection Notes for operation in the shaded areas.
- Regular Cooling operation with an EWT of less than 50°F (10.0°C) is not recommended unless variable water flow is available.
- Regular Heating operation with an EWT of more than 90°F (32°C) is not recommended unless variable water flow is available.
- For quiet operation and long term reliability, it is recommended that systems be designed to avoid continuous operation in the outlined areas.
- Performance capacities shown in thousands of Btuh
- Hot Water Generator Capacity is based on 90°F entering water and 0.5 GPM/Ton.

ClimateMaster works continually to improve its products. As a result, the design and specifications of each product at the time of order may be changed without notice and may not be as described herein. Please contact ClimateMaster's Customer Service Department at 1-800-299-9747 for specific information on the current design and specifications. Statements and other information contained herein are not express warranties and do not form the basis of any bargain between the parties, but are merely ClimateMaster's opinion or commendation of its products. The latest version of this document is available at www.climatemaster.com. Engineered and assembled in the USA. © ClimateMaster, Inc. All Rights Reserved 2024

Performance Data SE*060 EC Blower Motor (Part Load)

Models:
SE
006-072

1700 CFM Rated Airflow

EWT °F	WPD			COOLING - EAT 80/67 °F							WPD			HEATING - EAT 70°F					
	FLOW GPM	PSI	FT	TC	SC	EC					FLOW GPM	PSI	FT	HC	EC				
						kW	HR	EER	LWT	HWG Cap					kW	HE	COP	LWT	HWG Cap
20	Operation Not Recommended										10.50	3.6	8.3	24.3	2.49	15.8	2.9	17.0	3.0
30	3.81	0.7	1.5	48.9	35.9	1.45	53.9	33.8	50.5	1.3	5.25	1.2	2.8	26.7	2.51	18.2	3.1	23.1	3.0
											7.95	2.2	5.1	27.6	2.51	19.1	3.2	25.2	3.1
40	5.55	1.0	2.4	50.4	38.1	1.63	55.9	31.0	61.3	1.3	10.50	3.1	7.2	28.1	2.52	19.5	3.3	26.3	3.1
											5.25	0.9	2.2	30.6	2.53	22.0	3.5	31.6	3.1
											7.95	1.9	4.3	31.9	2.54	23.2	3.7	34.2	3.2
50	5.55	1.0	2.4	50.4	38.1	1.63	55.9	31.0	61.3	1.3	10.50	2.7	6.3	32.5	2.54	23.9	3.8	35.5	3.3
											5.25	0.8	1.8	34.9	2.55	26.2	4.0	40.0	3.3
											7.95	1.6	3.7	36.5	2.56	27.8	4.2	43.0	3.4
60	5.55	1.0	2.4	50.4	38.1	1.63	55.9	31.0	61.3	1.3	10.50	2.4	5.6	37.4	2.56	28.6	4.3	44.5	3.5
											5.25	0.6	1.5	39.5	2.57	30.7	4.5	48.3	3.5
											7.95	1.4	3.3	41.5	2.58	32.7	4.7	51.8	3.7
70	5.55	1.0	2.4	50.4	38.1	1.63	55.9	31.0	61.3	1.3	10.50	2.2	5.1	42.5	2.58	33.7	4.8	53.6	3.8
											5.25	0.6	1.3	44.2	2.59	35.4	5.0	56.5	3.9
											7.95	1.3	3.1	46.6	2.59	37.7	5.3	60.5	4.0
80	5.55	1.0	2.4	50.4	38.1	1.63	55.9	31.0	61.3	1.3	10.50	2.0	4.7	47.8	2.60	39.0	5.4	62.6	4.1
											5.25	0.6	1.3	49.1	2.60	40.2	5.5	64.7	4.2
											7.95	1.2	2.9	51.8	2.61	42.9	5.8	69.2	4.4
85	5.55	1.0	2.4	50.4	38.1	1.63	55.9	31.0	61.3	1.3	10.50	1.9	4.4	53.3	2.61	44.4	6.0	71.6	4.5
											5.25	0.5	1.3	51.6	2.61	42.7	5.8	68.7	4.4
											7.95	1.2	2.8	54.5	2.61	45.6	6.1	73.5	4.5
90	5.55	1.0	2.4	50.4	38.1	1.63	55.9	31.0	61.3	1.3	10.50	1.8	4.3	56.0	2.61	47.1	6.3	76.0	4.7
											5.25	0.5	1.3	56.0	2.61	47.1	6.3	76.0	4.7
											7.95	1.2	2.8	58.0	2.61	49.1	6.5	80.0	4.9
100	5.55	1.0	2.4	50.4	38.1	1.63	55.9	31.0	61.3	1.3	4.34	0.1	0.2	52.3	2.61	43.4	5.9	70.0	4.7
											5.25	0.5	1.3	52.3	2.61	43.4	5.9	70.0	4.7
											7.95	1.2	2.8	54.3	2.61	45.4	6.1	75.0	4.9
110	5.55	1.0	2.4	50.4	38.1	1.63	55.9	31.0	61.3	1.3	2.9	0.1	0.23	52.3	2.61	43.44	5.88	70.0	4.7
											5.25	0.5	1.3	52.3	2.61	43.44	5.88	70.0	4.7
											7.95	1.2	2.7	54.3	2.61	45.44	6.08	75.0	4.9
120	5.55	1.0	2.4	50.4	38.1	1.63	55.9	31.0	61.3	1.3	2.17	0.1	0.23	52.3	2.61	43.44	5.88	70.0	4.7
											5.25	0.5	1.2	52.3	2.61	43.44	5.88	70.0	4.7
											7.95	1.2	2.7	54.3	2.61	45.44	6.08	75.0	4.9

- Interpolation is permissible; extrapolation is not.
- All entering air conditions are 80°F (26.6°C) DB and 67°F (19.4°C) WB in cooling, and 70°F (21°C) DB in heating.
- AHRI/ISO certified conditions are 80.6°F (27°C) DB and 66.2°F (19°C) WB in cooling and 68°F (20°C) DB in heating.
- Table does not reflect fan or pump power corrections for AHRI/ISO conditions.
- All performance is based upon the lower voltage of dual voltage rated units.
- Performance stated is at the rated power supply; performance may vary as the power supply varies from the rated.
- Operation below 40°F (10.0°C) EWT is based upon 20% methanol antifreeze solution.
- Operation below 60°F (15.5°C) EWT requires optional insulated water/refrigerant circuit.
- See performance correction tables for operating conditions other than those listed above.
- See Performance Data Selection Notes for operation in the shaded areas.
- Regular Cooling operation with an EWT of less than 50°F (10.0°C) is not recommended unless variable water flow is available.
- Regular Heating operation with an EWT of more than 90°F (32°C) is not recommended unless variable water flow is available.
- For quiet operation and long term reliability, it is recommended that systems be designed to avoid continuous operation in the outlined areas.
- Performance capacities shown in thousands of Btuh
- Hot Water Generator Capacity is based on 90°F entering water and 0.5 GPM/Ton.

ClimateMaster works continually to improve its products. As a result, the design and specifications of each product at the time of order may be changed without notice and may not be as described herein. Please contact ClimateMaster's Customer Service Department at 1-800-299-9747 for specific information on the current design and specifications. Statements and other information contained herein are not express warranties and do not form the basis of any bargain between the parties, but are merely ClimateMaster's opinion or commendation of its products. The latest version of this document is available at www.climatemaster.com. Engineered and assembled in the USA. © ClimateMaster, Inc. All Rights Reserved 2024

Performance Data SE*060 EC Blower Motor (Full Load)

Models:
SE
006-072

1900 CFM Rated Airflow

EWT °F	WPD			COOLING - EAT 80/67 °F							WPD			HEATING - EAT 70°F															
	FLOW GPM	PSI	FT	TC	SC	EC					FLOW GPM	PSI	FT	HC	EC														
						kW	HR	EER	LWT	HWG Cap					kW	HE	COP	LWT	HWG Cap										
20	Operation Not Recommended										15.00	6.5	15.0	38.9	3.44	27.1	3.3	16.4	3.9										
30	5.41	1.0	2.3	71.7	50.2	2.74	81.1	26.2	60.0	2.4	7.50	2.0	4.6	42.4	3.50	30.4	3.5	21.9	4.2										
											11.25	3.8	8.8	44.0	3.53	31.9	3.6	24.3	4.3										
											15.00	5.6	13.0	44.8	3.55	32.7	3.7	25.6	4.3										
40	7.68	1.7	3.9	67.5	47.6	2.71	76.8	24.9	60.0	2.4	7.50	1.6	3.7	48.1	3.60	35.8	3.9	30.5	4.5										
											11.25	3.3	7.6	50.1	3.64	37.7	4.0	33.3	4.5										
											15.00	4.9	11.4	51.2	3.66	38.7	4.1	34.8	4.5										
50	7.50	1.3	3.1	68.9	49.2	3.02	79.3	22.8	71.1	3.6	7.50	1.3	3.1	54.1	3.71	41.5	4.3	38.9	4.9										
											11.25	2.9	6.6	56.5	3.75	43.7	4.4	42.2	5.0										
											15.00	4.4	10.2	57.8	3.78	44.9	4.5	44.0	5.1										
60	7.50	1.2	2.7	67.9	49.3	3.31	79.2	20.5	81.1	3.8	7.50	1.2	2.7	60.3	3.83	47.3	4.6	47.4	5.4										
											11.25	2.6	6.0	63.1	3.88	49.9	4.8	51.1	5.6										
											15.00	4.0	9.3	64.6	3.91	51.3	4.8	53.2	5.8										
70	7.50	1.1	2.5	65.4	48.5	3.62	77.7	18.0	90.7	4.6	7.50	1.1	2.5	66.6	3.95	53.2	4.9	55.8	5.9										
											11.25	2.4	5.6	69.8	4.02	56.1	5.1	60.0	6.4										
											15.00	3.7	8.6	71.5	4.06	57.7	5.2	62.3	6.8										
80	7.50	1.0	2.4	61.9	47.0	3.97	75.4	15.6	100.1	5.6	7.50	1.0	2.4	73.0	4.09	59.0	5.2	64.3	6.4										
											11.25	2.3	5.3	76.4	4.17	62.2	5.4	68.9	7.1										
											15.00	3.5	8.2	78.3	4.22	63.9	5.4	71.5	7.6										
85	7.50	1.0	2.4	60.0	46.1	4.16	74.2	14.4	104.8	6.3	7.50	1.0	2.4	76.1	4.16	61.9	5.4	68.5	6.8										
											11.25	2.3	5.2	79.7	4.25	65.2	5.5	73.4	7.4										
											15.00	3.5	8.0	81.6	4.30	66.9	5.6	76.1	8.0										
90	7.50	1.0	2.4	58.0	45.2	4.36	72.9	13.3	109.4	7.4	6.30	0.1	0.2	77.2	4.19	63.0	5.4	70.0	8.0										
																				11.25	2.2	5.2	80.6	4.09	74.6	14.8	103.3	6.6	
																				15.00	3.4	7.9	81.9	4.70	75.4	15.6	100.1	6.1	
100	7.50	1.0	2.4	54.1	43.4	4.83	70.6	11.2	118.8	8.9	1.82	0.1	0.2	33.1	1.72	27.2	5.6	70.0	8.0										
																				11.25	2.2	5.1	56.6	44.5	4.52	72.0	12.5	112.8	8.2
																				15.00	3.3	7.7	57.9	45.2	4.37	72.8	13.2	109.7	7.4
110	7.50	1.0	2.3	50.6	41.8	5.39	69.0	9.4	128.4	10.7	1.36	0.1	0.2	33.1	1.72	27.2	5.6	70.0	8.0										
																				11.25	2.1	4.9	52.7	42.7	5.03	69.8	10.5	122.4	9.8
																				15.00	3.3	7.6	53.9	43.3	4.86	70.4	11.1	119.4	8.9
120	7.50	0.9	2.1	48.1	41.0	6.07	68.8	7.9	138.3	12.4	1.09	0.1	0.2	33.1	1.72	27.2	5.6	70.0	8.0										
																				11.25	2.1	4.8	49.5	41.4	5.64	68.7	8.8	132.2	11.2
																				15.00	3.2	7.5	50.4	41.7	5.44	68.9	9.3	129.2	10.6

- Interpolation is permissible; extrapolation is not.
- All entering air conditions are 80°F (26.6°C) DB and 67°F (19.4°C) WB in cooling, and 70°F (21°C) DB in heating.
- AHRI/ISO certified conditions are 80.6°F (27°C) DB and 66.2°F (19°C) WB in cooling and 68°F (20°C) DB in heating.
- Table does not reflect fan or pump power corrections for AHRI/ISO conditions.
- All performance is based upon the lower voltage of dual voltage rated units.
- Performance stated is at the rated power supply; performance may vary as the power supply varies from the rated.
- Operation below 40°F (10.0°C) EWT is based upon 20% methanol antifreeze solution.
- Operation below 60°F (15.5°C) EWT requires optional insulated water/refrigerant circuit.
- See performance correction tables for operating conditions other than those listed above.
- See Performance Data Selection Notes for operation in the shaded areas.
- Regular Cooling operation with an EWT of less than 50°F (10.0°C) is not recommended unless variable water flow is available.
- Regular Heating operation with an EWT of more than 90°F (32°C) is not recommended unless variable water flow is available.
- For quiet operation and long term reliability, it is recommended that systems be designed to avoid continuous operation in the outlined areas.
- Performance capacities shown in thousands of Btuh
- Hot Water Generator Capacity is based on 90°F entering water and 0.5 GPM/Ton.

ClimateMaster works continually to improve its products. As a result, the design and specifications of each product at the time of order may be changed without notice and may not be as described herein. Please contact ClimateMaster's Customer Service Department at 1-800-299-9747 for specific information on the current design and specifications. Statements and other information contained herein are not express warranties and do not form the basis of any bargain between the parties, but are merely ClimateMaster's opinion or commendation of its products. The latest version of this document is available at www.climatemaster.com. Engineered and assembled in the USA. © ClimateMaster, Inc. All Rights Reserved 2024

Performance Data SE*072 EC Blower Motor (Part Load)

Models:
SE
006-072

1700 CFM Rated Airflow

EWT °F	WPD			COOLING - EAT 80/67 °F							WPD			HEATING - EAT 70°F					
	FLOW GPM	PSI	FT	TC	SC	EC					FLOW GPM	PSI	FT	HC	EC				
						kW	HR	EER	LWT	HWG Cap					kW	HE	COP	LWT	HWG Cap
20	Operation Not Recommended										13.70	5.1	11.9	32.8	3.26	21.7	2.9	16.8	3.9
30	4.7	0.6	1.4	63.8	46.5	2.0	70.6	31.9	60.0	1.9	6.90	1.6	3.7	36.4	3.33	25.1	3.2	22.7	4.2
											10.30	3.1	7.2	37.7	3.34	26.3	3.3	24.9	4.3
											13.70	4.6	10.7	38.3	3.35	26.9	3.4	26.1	4.4
40	6.87	1.4	3.2	61.6	44.9	2.07	68.7	29.8	60.0	1.9	6.90	1.4	3.2	41.1	3.37	29.6	3.6	31.4	4.5
											10.30	2.8	6.5	42.4	3.37	30.9	3.7	34.0	4.6
											13.70	4.2	9.8	43.1	3.38	31.5	3.7	35.4	4.8
50	6.90	1.3	2.9	61.4	45.5	2.35	69.4	26.1	70.1	2.7	6.90	1.3	2.9	45.4	3.38	33.9	3.9	40.2	4.9
											10.30	2.6	6.0	46.8	3.37	35.3	4.1	43.1	5.1
											13.70	3.9	9.0	47.6	3.37	36.1	4.1	44.7	5.2
60	6.90	1.2	2.7	59.9	45.1	2.68	69.0	22.3	80.0	3.3	6.90	1.2	2.7	49.8	3.37	38.3	4.3	48.9	5.4
											10.30	2.4	5.6	51.6	3.38	40.1	4.5	52.2	5.6
											13.70	3.7	8.5	52.6	3.38	41.1	4.6	54.0	5.7
70	6.90	1.1	2.5	57.4	44.0	3.07	67.9	18.7	89.7	4.1	6.90	1.1	2.5	54.7	3.40	43.1	4.7	57.5	6.0
											10.30	2.3	5.3	57.2	3.42	45.5	4.9	61.2	6.2
											13.70	3.5	8.1	58.6	3.44	46.9	5.0	63.2	6.4
80	6.90	1.0	2.4	54.4	42.5	3.49	66.3	15.6	99.2	5.1	6.90	1.0	2.4	60.7	3.48	48.8	5.1	65.8	6.7
											10.30	2.2	5.1	64.1	3.54	52.0	5.3	69.9	6.9
											13.70	3.3	7.7	66.1	3.58	53.9	5.4	72.1	7.1
85	6.90	1.0	2.3	52.7	41.7	3.73	65.4	14.1	104.0	6.0	6.90	1.0	2.3	64.1	3.54	52.0	5.3	69.9	7.0
											10.30	2.1	5.0	68.2	3.63	55.8	5.5	74.2	7.3
											13.70	3.3	7.6	70.6	3.69	58.0	5.6	76.5	7.4
90	6.90	1.0	2.3	50.9	40.8	3.97	64.5	12.8	108.7	6.3	5.16	0.1	0.2	63.5	3.51	51.6	5.3	70.0	7.4
											10.30	2.1	4.8	63.5	3.51	51.6	5.3	70.0	7.4
											13.70	3.2	7.4	63.5	3.51	51.6	5.3	70.0	7.4
100	6.90	0.9	2.1	47.3	39.2	4.49	62.7	10.5	118.2	7.6	3.44	0.1	0.2	63.5	3.51	51.6	5.3	70.0	7.4
											10.30	2.0	4.6	63.5	3.51	51.6	5.3	70.0	7.4
											13.70	3.1	7.1	63.5	3.51	51.6	5.3	70.0	7.4
110	6.90	0.8	2.0	43.8	37.7	5.06	61.1	8.7	127.7	9.1	2.58	0.1	0.2	63.5	3.51	51.6	5.3	70.0	7.4
											10.30	1.9	4.4	63.5	3.51	51.6	5.3	70.0	7.4
											13.70	2.9	6.8	63.5	3.51	51.6	5.3	70.0	7.4
120	6.90	0.7	1.7	40.7	36.7	5.69	60.1	7.2	137.4	10.8	2.06	0.1	0.2	63.5	3.51	51.6	5.31	70.0	7.4
											10.30	1.7	4.0	63.5	3.51	51.6	5.31	70.0	7.4
											13.70	2.7	6.3	63.5	3.51	51.6	5.31	70.0	7.4

- Interpolation is permissible; extrapolation is not.
- All entering air conditions are 80°F (26.6°C) DB and 67°F (19.4°C) WB in cooling, and 70°F (21°C) DB in heating.
- AHRI/ISO certified conditions are 80.6°F (27°C) DB and 66.2°F (19°C) WB in cooling and 68°F (20°C) DB in heating.
- Table does not reflect fan or pump power corrections for AHRI/ISO conditions.
- All performance is based upon the lower voltage of dual voltage rated units.
- Performance stated is at the rated power supply; performance may vary as the power supply varies from the rated.
- Operation below 40°F (10.0°C) EWT is based upon 20% methanol antifreeze solution.
- Operation below 60°F (15.5°C) EWT requires optional insulated water/refrigerant circuit.
- See performance correction tables for operating conditions other than those listed above.
- See Performance Data Selection Notes for operation in the shaded areas.
- Regular Cooling operation with an EWT of less than 50°F (10.0°C) is not recommended unless variable water flow is available.
- Regular Heating operation with an EWT of more than 90°F (32°C) is not recommended unless variable water flow is available.
- For quiet operation and long term reliability, it is recommended that systems be designed to avoid continuous operation in the outlined areas.
- Performance capacities shown in thousands of Btuh
- Hot Water Generator Capacity is based on 90°F entering water and 0.5 GPM/Ton.

ClimateMaster works continually to improve its products. As a result, the design and specifications of each product at the time of order may be changed without notice and may not be as described herein. Please contact ClimateMaster's Customer Service Department at 1-800-299-9747 for specific information on the current design and specifications. Statements and other information contained herein are not express warranties and do not form the basis of any bargain between the parties, but are merely ClimateMaster's opinion or commendation of its products. The latest version of this document is available at www.climatemaster.com. Engineered and assembled in the USA. © ClimateMaster, Inc. All Rights Reserved 2024

Performance Data SE*072 EC Blower Motor (Full Load)

Models:
SE
006-072

1900 CFM Rated Airflow

EWT °F	WPD			COOLING - EAT 80/67 °F							WPD			HEATING - EAT 70°F					
	FLOW GPM	PSI	FT	TC	SC	EC					FLOW GPM	PSI	FT	HC	EC				
						kW	HR	EER	LWT	HWG Cap					kW	HE	COP	LWT	HWG Cap
20	Operation Not Recommended										17.00	7.6	17.7	47.9	4.22	33.5	3.3	16.1	4.2
30	6.09	0.9	2.0	79.7	56.4	3.42	91.3	23.3	60.0	2.4	8.50	2.2	5.0	50.2	4.37	35.3	3.4	21.7	4.3
											12.75	4.5	10.4	51.5	4.44	36.3	3.4	24.3	4.3
											17.00	6.8	15.7	52.2	4.48	36.9	3.4	25.7	4.3
40	8.93	2.1	4.8	77.8	54.8	3.37	89.3	23.1	60.0	2.4	8.50	1.9	4.3	55.0	4.61	39.2	3.5	30.8	4.5
											12.75	4.0	9.3	56.7	4.69	40.7	3.5	33.6	4.5
											17.00	6.1	14.2	57.6	4.73	41.5	3.6	35.1	4.6
50	8.50	1.7	3.8	79.4	55.2	3.72	92.1	21.3	71.4	4.2	8.50	1.7	3.8	60.5	4.85	44.0	3.7	39.6	5.0
	12.75	3.6	8.4	79.9	55.1	3.48	91.8	23.0	64.1	3.8	12.75	3.6	8.4	62.7	4.93	45.9	3.7	42.8	5.1
	17.00	5.6	13.0	79.8	54.9	3.37	91.3	23.7	60.5	3.5	17.00	5.6	13.0	63.9	4.97	47.0	3.8	44.5	5.1
60	8.50	1.5	3.4	77.6	54.5	4.09	91.6	19.0	81.2	4.6	8.50	1.5	3.4	66.8	5.07	49.5	3.9	48.4	5.8
	12.75	3.4	7.8	79.0	55.1	3.82	92.1	20.7	74.2	4.4	12.75	3.4	7.8	69.5	5.16	51.8	3.9	51.9	6.5
	17.00	5.2	12.1	79.5	55.2	3.69	92.1	21.5	70.7	4.2	17.00	5.2	12.1	70.9	5.21	53.2	4.0	53.7	7.1
70	8.50	1.4	3.2	74.8	53.2	4.51	90.2	16.6	90.5	5.8	8.50	1.4	3.2	73.5	5.29	55.4	4.1	57.0	6.5
	12.75	3.2	7.3	76.9	54.2	4.20	91.2	18.3	84.0	5.2	12.75	3.2	7.3	76.7	5.39	58.3	4.2	60.9	7.3
	17.00	4.9	11.4	77.8	54.6	4.06	91.6	19.2	80.6	5.0	17.00	4.9	11.4	78.4	5.45	59.8	4.2	63.0	7.9
80	8.50	1.3	3.0	71.3	51.4	4.99	88.3	14.3	99.6	7.2	8.50	1.3	3.0	80.5	5.51	61.7	4.3	65.5	7.1
	12.75	3.0	7.0	73.8	52.7	4.64	89.7	15.9	93.5	6.7	12.75	3.0	7.0	84.2	5.62	65.0	4.4	69.8	7.9
	17.00	4.7	10.9	75.0	53.3	4.48	90.3	16.7	90.3	6.3	17.00	4.7	10.9	86.2	5.68	66.8	4.4	72.1	8.7
85	8.50	1.3	3.0	69.4	50.5	5.26	87.3	13.2	103.9	8.2	8.50	1.3	3.0	84.1	5.62	65.0	4.4	69.7	7.7
	12.75	3.0	6.8	72.0	51.8	4.89	88.7	14.7	98.2	7.4	12.75	3.0	6.8	88.0	5.73	68.5	4.5	74.3	8.1
	17.00	4.6	10.7	73.3	52.4	4.72	89.4	15.5	95.0	6.9	17.00	4.6	10.7	90.1	5.79	70.4	4.6	76.7	8.8
90	8.50	1.3	2.9	67.4	49.5	5.56	86.3	12.1	108.2	9.1	6.52	0.1	0.2	84.4	5.62	65.2	4.4	70.0	8.8
	12.75	2.9	6.7	70.1	50.8	5.16	87.7	13.6	102.7	8.3									
	17.00	4.5	10.5	71.5	51.5	4.97	88.4	14.4	99.8	7.4									
100	8.50	1.2	2.8	63.2	47.6	6.22	84.5	10.2	116.6	10.6	4.34	0.1	0.2	84.4	5.62	65.2	4.4	70.0	8.8
	12.75	2.8	6.5	66.0	48.9	5.76	85.7	11.5	111.7	9.9									
	17.00	4.4	10.2	67.4	49.5	5.55	86.4	12.2	109.0	9.0									
110	8.50	1.2	2.7	59.2	45.8	7.00	83.0	8.5	124.7	12.3	3.26	0.1	0.2	84.4	5.62	65.2	4.4	70.0	8.8
	12.75	2.7	6.3	61.8	46.9	6.47	83.9	9.6	120.5	11.7									
	17.00	4.3	9.9	63.2	47.6	6.22	84.4	10.2	118.1	10.6									
120	8.50	1.1	2.6	55.4	44.4	7.92	82.4	7.0	132.5	14.1	2.61	0.1	0.2	84.4	5.62	65.2	4.4	70.0	8.8
	12.75	2.6	6.1	57.8	45.2	7.31	82.7	7.9	129.0	13.6									
	17.00	4.1	9.6	59.1	45.8	7.02	83.0	8.4	127.0	12.4									

- Interpolation is permissible; extrapolation is not.
- All entering air conditions are 80°F (26.6°C) DB and 67°F (19.4°C) WB in cooling, and 70°F (21°C) DB in heating.
- AHRI/ISO certified conditions are 80.6°F (27°C) DB and 66.2°F (19°C) WB in cooling and 68°F (20°C) DB in heating.
- Table does not reflect fan or pump power corrections for AHRI/ISO conditions.
- All performance is based upon the lower voltage of dual voltage rated units.
- Performance stated is at the rated power supply; performance may vary as the power supply varies from the rated.
- Operation below 40°F (10.0°C) EWT is based upon 20% methanol antifreeze solution.
- Operation below 60°F (15.5°C) EWT requires optional insulated water/refrigerant circuit.
- See performance correction tables for operating conditions other than those listed above.
- See Performance Data Selection Notes for operation in the shaded areas.
- Regular Cooling operation with an EWT of less than 50°F (10.0°C) is not recommended unless variable water flow is available.
- Regular Heating operation with an EWT of more than 90°F (32°C) is not recommended unless variable water flow is available.
- For quiet operation and long term reliability, it is recommended that systems be designed to avoid continuous operation in the outlined areas.
- Performance capacities shown in thousands of Btuh
- Hot Water Generator Capacity is based on 90°F entering water and 0.5 GPM/Ton.

ClimateMaster works continually to improve its products. As a result, the design and specifications of each product at the time of order may be changed without notice and may not be as described herein. Please contact ClimateMaster's Customer Service Department at 1-800-299-9747 for specific information on the current design and specifications. Statements and other information contained herein are not express warranties and do not form the basis of any bargain between the parties, but are merely ClimateMaster's opinion or commendation of its products. The latest version of this document is available at www.climatemaster.com. Engineered and assembled in the USA. © ClimateMaster, Inc. All Rights Reserved 2024

Blower Performance: CV EC Standard Unit

Models:
SE
006-072

CV EC MOTOR ADVANTAGE

A major benefit of the CV EC motor over other blower motor types is its ability to adjust airflow remotely through the iGate 2 web portal, mobile app, or directly at the unit with the Wireless Service Tool. Airflow levels can be adjusted in increments of 25 CFM from the unit's minimum and maximum CFM range (see the CV EC motor configuration table for details).

Blower Performance: CV EC Blower Motor Standard Unit

Model	Max ESP (in wg)	Range	Cooling Mode			Dehumid Mode			Heating Mode		
			Stage 2	Stage 1	Fan	Stage 2	Stage 1	Fan	Stage 2	Stage 1	Fan
SE006	0.60	Minimum	150						150		
		Default	240						240		
		Maximum	300						300		
SE009	1.00	Minimum	225						225		
		Default	300						300		
		Maximum	375						375		
SE012	0.60	Minimum	300						300		
		Default	350						350		
		Maximum	450						450		
SE018	1.00	Minimum	450						450		
		Default	750						750		
		Maximum	800						800		
SE024	0.75	Minimum	600	450	300	600	450	300	600	450	300
		Default	750	575	350	650	500	350	750	575	350
		Maximum	850	650	850	800	600	850	850	850	850
SE036	0.6	Minimum	900	600	450	900	600	450	900	600	450
		Default	1,125	750	525	975	650	525	1,125	750	525
		Maximum	1,250	950	1,250	1,200	800	1,250	1,250	1,250	1,250
SE048	0.75	Minimum	1,200	900	600	1,200	900	600	1,200	900	600
		Default	1,500	1,125	700	1,300	975	700	1,500	1,125	700
		Maximum	1,700	1,300	1,700	1,600	1,200	1,700	1,700	1,700	1,700
SE060	0.75	Minimum	1,500	1,200	750	1,500	1,200	750	1,500	1,200	750
		Default	1,875	1,500	875	1,625	1,300	875	1,875	1,500	875
		Maximum	2,100	1,700	2,100	2,000	1,600	2,100	2,100	2,100	2,100
SE072	0.75	Minimum	1,500	1,200	750	1,500	1,200	750	1,500	1,200	750
		Default	1,875	1,500	875	1,625	1,300	875	1,875	1,500	875
		Maximum	2,100	1,700	2,100	2,000	1,600	2,100	2,100	2,100	2,100

- Blower performance data is based on the lowest nameplate voltage setting.
- Blower performance is based on a wet coil with clean 1-inch filter.
- Blower performance is based on operating conditions of 80°F DB and 67°F WB.
- Airflow is controller within ±5% up to Max ESP shown with wet coil and standard 1" fiberglass air filter.
- Cells in grey - option not available
- The maximum allowable altitude of installation for this product is 6,561 ft (2,000 m).

Electrical Data

CV EC Blower Motor Standard Unit

Models:
SE
006-072

Model	VOLTAGE CODE	VOLTAGE	VOLTAGE MIN/MAX	COMPRESSOR			FAN MOTOR FLA	TOTAL UNIT FLA	MIN CIRCUIT AMP	FUSE/HACR AMP
				QTY	RLA	LRA				
SE006	G.J.	208/230-1-60	187/252	1	3.8	27	1.5	5.27	6.21	15
	E.D.	265-1-60	249/291	1	2.5	22	1.4	3.9	4.53	15
SE009	G.J.	208/230-1-60	187/252	1	5.2	27	2.6	7.8	9.09	15
	E.D.	265-1-60	249/291	1	3.5	32	2.5	6.0	6.91	15
SE012	G.J.	208/230-1-60	187/252	1	6.7	27	2.6	9.3	10.93	15
	E.D.	265-1-60	249/291	1	4.6	32	2.5	7.1	8.27	15
SE018	G.J.	208/230-1-60	187/252	1	13.3	35	4.2	17.5	20.8	20
	E.D.	265-1-60	249/291	1	6.5	40	3.4	9.9	11.6	15
SE024	G.J.	208/230-1-60	187.0/252.0	1	10.3	62	4.2	14.5	17.1	25
	H.K.	208/230-3-60	187.0/252.0	1	6.3	56	4.2	10.5	12.1	15
	F.L.	460-3-60*	432.0/504.0	1	3.8	29	3.4	7.2	8.2	15
SE036	G.J.	208/230-1-60	187.0/252.0	1	14.6	76	5.9	20.5	24.2	30
	H.K.	208/230-3-60	187.0/252.0	1	8.6	70	5.9	14.5	16.7	20
	F.L.	460-3-60*	432.0/504.0	1	4.5	39	4.8	9.3	10.4	15
SE048	G.J.	208/230-1-60	187.0/252.0	1	18.3	138	5.9	24.2	28.8	45
	H.K.	208/230-3-60	187.0/252.0	1	11.2	112	5.9	17.1	19.9	30
	F.L.	460-3-60*	432.0/504.0	1	6.8	61.8	4.8	11.6	13.3	20
SE060	G.J.	208/230-1-60	187.0/252.0	1	22.3	149	7.5	29.8	35.4	50
	H.K.	208/230-3-60	187.0/252.0	1	14	150	7.5	21.5	25.0	30
	F.L.	460-3-60*	432.0/504.0	1	6.3	58	6.2	12.5	14.1	20
SE072	G.J.	208/230-1-60	187.0/252.0	1	31.2	166	7.5	38.7	46.5	70
	H.K.	208/230-3-60	187.0/252.0	1	21.4	162.3	7.5	21.5	25.0	30
	F.L.	460-3-60*	432.0/504.0	1	10.1	70.8	6.2	12.5	14.1	20

Notes:

- Wire length based on one way measurement with 2% voltage drop.
- Wire size based on 60°C copper conductor.
- All fuses Class RK-5.

***Neutral connection required! All F and L voltage (460VAC) units with a CV EC motor require a four-wire power supply with neutral. The CV EC motor is rated 265VAC and is wired between one hot leg and neutral.**

Electrical Data: CV EC Blower Motor with Internal Secondary Pump

Models:
SE
006-072

Model	VOLTAGE CODE	VOLTAGE	VOLTAGE MIN/MAX	COMPRESSOR			PUMP FLA	FAN MOTOR FLA	TOTAL UNIT FLA	MIN CIRCUIT AMP	FUSE/HACR AMP
				QTY	RLA	LRA					
SE018	G.J.	208/230-1-60	187/252	1	13.3	35	0.43	4.2	17.9	21.2	20
	E.D.	265-1-60	249/291	1	6.5	40	0.7	3.4	10.6	12.3	20
SE024	G.J.	208/240-1-60	187/252	1	10.3	62	0.8	4.2	15.3	17.9	25
	H.K.	208/240-3-60	187/252	1	6.3	56	0.8	4.2	11.3	12.9	15
	F.L.	460-3-60*	432/504	1	3.8	29	0.7	3.4	7.9	8.9	15
SE036	G.J.	208/240-1-60	187/252	1	14.6	76	0.8	5.9	21.3	25.0	30
	H.K.	208/240-3-60	187/252	1	8.6	70	0.8	5.9	15.3	17.5	20
	F.L.	460-3-60*	432/504	1	4.5	39	0.7	4.8	10.0	11.1	15
SE048	G.J.	208/240-1-60	187/252	1	18.3	138	1.1	5.9	25.3	29.9	45
	H.K.	208/240-3-60	187/252	1	11.2	112	1.1	5.9	18.2	21.0	30
	F.L.	460-3-60*	432/504	1	6.8	61.8	1.3	4.8	12.9	14.6	20
SE060	G.J.	208/240-1-60	187/252	1	22.3	149	1.1	7.5	30.9	36.5	50
	H.K.	208/240-3-60	187/252	1	14	150	1.1	7.5	22.6	26.1	30
	F.L.	460-3-60*	432/504	1	6.3	58	1.3	6.2	13.8	15.4	20
SE072	G.J.	208/240-1-60	187/252	1	31.2	166	1.1	7.5	39.8	47.6	70
	H.K.	208/240-3-60	187/252	1	21.4	162.3	1.1	7.5	22.6	26.1	30
	F.L.	460-3-60*	432/504	1	10.1	70.8	1.3	6.2	13.8	15.4	20

Notes:

- Wire length based on one way measurement with 2% voltage drop.
- Wire size based on 60°C copper conductor.
- All fuses Class RK-5.

***Neutral connection required! All F and L voltage (460VAC) units with a CV EC motor require a four-wire power supply with neutral. The CV EC motor is rated 265VAC and is wired between one hot leg and neutral.**

Electrical Data: CV EC Blower Motor Standard Unit with Variable Pump

Models:
SE
006-072

Units with Standard Head Variable Pump

Model	Voltage Code	Voltage	Voltage Min/Max	Compressor			Pump Motor FLA	Fan Motor FLA	Total Unit FLA	Min Circ Amp	Max Fuse/HACR Amp
				RLA	LRA	Qty					
SE024	G.J.	208/230-1-60	187/252	10.3	62	1	0.64	4.2	15.1	17.7	25
	H.K.	208/230-3-60	187/252	6.3	56	1	0.64	4.2	11.1	12.7	15
SE036	G.J.	208/230-1-60	187/252	14.6	76	1	0.64	5.9	21.1	24.8	30
	H.K.	208/230-3-60	187/252	8.6	70	1	0.64	5.9	15.1	17.3	25
SE048	G.J.	208/230-1-60	187/252	18.3	138	1	0.64	5.9	24.8	29.4	45
	H.K.	208/230-3-60	187/252	11.2	112	1	0.64	5.9	17.7	20.5	30
SE060	G.J.	208/230-1-60	187/252	22.3	149	1	0.64	7.5	30.4	36.0	50
	H.K.	208/230-3-60	187/252	14	150	1	0.64	7.5	22.1	25.6	30
SE072	G.J.	208/230-1-60	187/252	31.2	166.0	1	0.64	7.5	39.3	47.1	70
	H.K.	208/230-3-60	187/252	21.4	162.3	1	0.64	5.9	17.7	20.5	30

Notes:

- Wire length based on one way measurement with 2% voltage drop.
- Wire size based on 60°C copper conductor.
- All fuses Class RK-5.

Units with High Head Variable Pump

Unit Size	Voltage Code	Voltage	Min/Max Voltage	Compressor			Pump Motor FLA	Fan Motor FLA	Total Unit FLA	Min Circ Amp	Max Fuse/HACR Amp
				RLA	LRA	Qty					
SE024	G.J.	208/230-1-60	187/252	10.3	62	1	1.44	4.2	15.9	18.5	25
	H.K.	208/230-3-60	187/252	6.3	56	1	1.44	4.2	11.9	13.5	15
SE036	G.J.	208/230-1-60	187/252	14.6	76	1	1.44	5.9	21.9	25.6	40
	H.K.	208/230-3-60	187/252	8.6	70	1	1.44	5.9	15.9	18.1	25
SE048	G.J.	208/230-1-60	187/252	18.3	138	1	1.44	5.9	25.6	30.2	45
	H.K.	208/230-3-60	187/252	11.2	112	1	1.44	5.9	18.5	21.3	30
SE060	G.J.	208/230-1-60	187/252	22.3	149	1	1.44	7.5	31.2	36.8	50
	H.K.	208/230-3-60	187/252	14	150	1	1.44	7.5	22.9	26.4	40
SE072	G.J.	208/230-1-60	187/252	31.2	166.0	1	1.44	7.5	40.1	47.9	70
	H.K.	208/230-3-60	187/252	21.4	162.3	1	1.44	5.9	18.5	21.3	30

Notes:

- Wire length based on one way measurement with 2% voltage drop.
- Wire size based on 60°C copper conductor.
- All fuses Class RK-5.

Part Load Performance: Correction Tables

Models:
SE
006-072

Cooling Correction

Entering Air WB °F	Total Capacity	Sensible Cooling Capacity Multipliers - Entering DB °F									Power	Heat of Rejection
		65	70	75	80	80.6	85	90	95	100		
50	0.883	1.099	1.241	*	*	*	*	*	*	*	0.985	0.901
55	0.903	0.871	1.060	1.271	*	*	*	*	*	*	0.989	0.918
60	0.935	0.617	0.844	1.079	1.319	1.349	*	*	*	*	0.993	0.945
65	0.979		0.595	0.849	1.096	1.128	1.342	*	*	*	0.998	0.982
66.2	0.991		0.531	0.789	1.040	1.070	1.284	1.522	*	*	0.999	0.993
67	1.000		0.486	0.747	1.000	1.030	1.245	1.481	*	*	1.000	1.000
70	1.035			0.583	0.842	0.873	1.090	1.327	1.552	*	1.003	1.030
75	1.105				0.552	0.584	0.811	1.057	1.290	1.510	1.008	1.088

Notes:

- AHRI/ISO/ASHRAE 13256-1 uses entering air conditions of Cooling - 80.6°F (27°C) DB/ 66.2°F (19°C) WB, and Heating 68°F (20°C) DB/ 59°F (15°C) WB entering air temperature.
- Asterisks indicate that no correction factor is needed, Total Capacity equals Sensible capacity.
- Entering DB temperature range is based on operating limits, not on commission limits.
- Cooling and heating air corrections based on rated airflow.

Entering Air Heating Correction

Entering Air WB °F	Heating Capacity	Power	Heat of Rejection
40	1.084	0.732	1.161
45	1.073	0.764	1.140
50	1.060	0.802	1.117
55	1.046	0.846	1.090
60	1.031	0.893	1.061
65	1.016	0.945	1.031
68	1.006	0.978	1.013
70	1.000	1.000	1.000
75	0.984	1.058	0.968
80	0.968	1.117	0.936

Airflow Correction

Airflow % of Rated	Cooling				Heating		
	Total Capacity	Sensible Capacity	Power	Heat of Rejection	Heating Capacity	Power	Heat of Extraction
60%	0.920	0.781	0.959	0.927	0.946	1.241	0.881
69%	0.942	0.832	0.964	0.946	0.960	1.163	0.915
75%	0.956	0.867	0.696	0.959	0.969	1.115	0.937
81%	0.969	0.901	0.975	0.970	0.978	1.076	0.956
88%	0.981	0.934	0.982	0.981	0.986	1.043	0.973
94%	0.991	0.967	0.990	0.991	0.993	1.018	0.988
100%	1.000	1.000	1.000	1.000	1.000	1.000	1.000
106%	1.007	1.033	1.011	1.008	1.006	0.990	1.010
113%	1.013	1.065	1.023	1.015	1.012	0.986	1.017
119%	1.018	1.098	1.036	1.021	1.017	0.983	1.024
125%	1.021	1.131	1.051	1.026	1.021	0.981	1.030
130%	1.023	1.159	1.063	1.030	1.024	0.979	1.034

ClimateMaster works continually to improve its products. As a result, the design and specifications of each product at the time of order may be changed without notice and may not be as described herein. Please contact ClimateMaster's Customer Service Department at 1-800-299-9747 for specific information on the current design and specifications. Statements and other information contained herein are not express warranties and do not form the basis of any bargain between the parties, but are merely ClimateMaster's opinion or commendation of its products. The latest version of this document is available at www.climatemaster.com. Engineered and assembled in the USA. © ClimateMaster, Inc. All Rights Reserved 2024

Full Load Performance: Correction Tables

Models:
SE
006-072

Cooling Correction

Entering Air WB °F	Total Capacity	Sensible Cooling Capacity Multipliers - Entering DB °F									Power	Heat of Rejection
		65	70	75	80	80.6	85	90	95	100		
50	0.850	1.174	*	*	*	*	*	*	*	*	0.953	0.87
55	0.880	0.902	1.115	*	*	*	*	*	*	*	0.964	0.896
60	0.922	0.646	0.875	1.103	1.329	*	*	*	*	*	0.977	0.932
65	0.975		0.639	0.869	1.096	1.123	1.320	*	*	*	0.993	0.979
66.2	0.990		0.582	0.812	1.039	1.066	1.262	*	*	*	0.997	0.991
67	1.000		0.545	0.774	1.000	1.027	1.223	1.444	*	*	1.000	1.000
70	1.040			0.630	0.853	0.880	1.075	1.297	*	*	1.011	1.035
75	1.117				0.601	0.627	0.821	1.046	1.275	1.510	1.033	1.101

Notes:

- AHRI/ISO/ASHRAE 13256-1 uses entering air conditions of Cooling - 80.6°F (27°C) DB/ 66.2°F (19°C) WB, and Heating 68°F (20°C) DB/ 59°F (15°C) WB entering air temperature.
- Asterisks indicate that no correction factor is needed, Total Capacity equals Sensible capacity.
- Entering DB temperature range is based on operating limits, not on commission limits.
- Cooling and heating air corrections based on rated airflow.

Entering Air Heating Correction

Entering Air WB °F	Heating Capacity	Power	Heat of Rejection
40	1.052	0.779	1.120
45	1.043	0.808	1.102
50	1.035	0.841	1.084
55	1.027	0.877	1.065
60	1.019	0.915	1.045
65	1.010	0.957	1.023
68	1.004	0.982	1.010
70	1.000	1.000	1.000
75	0.989	1.045	0.974
80	0.976	1.093	0.946

Airflow Correction

Airflow % of Rated	Cooling				Heating		
	Total Capacity	Sensible Capacity	Power	Heat of Rejection	Heating Capacity	Power	Heat of Extraction
60%	0.925	0.788	0.913	0.922	0.946	1.153	0.896
69%	0.946	0.829	0.926	0.942	0.959	1.107	0.924
75%	0.960	0.861	0.937	0.955	0.969	1.078	0.942
81%	0.972	0.895	0.950	0.968	0.977	1.053	0.959
88%	0.983	0.930	0.965	0.979	0.985	1.032	0.974
94%	0.992	0.965	0.982	0.990	0.993	1.014	0.988
100%	1.000	1.000	1.000	1.000	1.000	1.000	1.000
106%	1.007	1.033	1.020	1.009	1.006	0.989	1.011
113%	1.012	1.064	1.042	1.018	1.012	0.982	1.019
119%	1.016	1.092	1.066	1.025	1.018	0.979	1.027
125%	1.018	1.116	1.091	1.032	1.022	0.977	1.033
130%	1.019	1.132	1.112	1.037	1.026	0.975	1.038

ClimateMaster works continually to improve its products. As a result, the design and specifications of each product at the time of order may be changed without notice and may not be as described herein. Please contact ClimateMaster's Customer Service Department at 1-800-299-9747 for specific information on the current design and specifications. Statements and other information contained herein are not express warranties and do not form the basis of any bargain between the parties, but are merely ClimateMaster's opinion or commendation of its products. The latest version of this document is available at www.climatemaster.com. Engineered and assembled in the USA. © ClimateMaster, Inc. All Rights Reserved 2024

High Head and Standard Variable Pump Performance

Models:
SE
006-072

Standard Head Variable Pump Performance

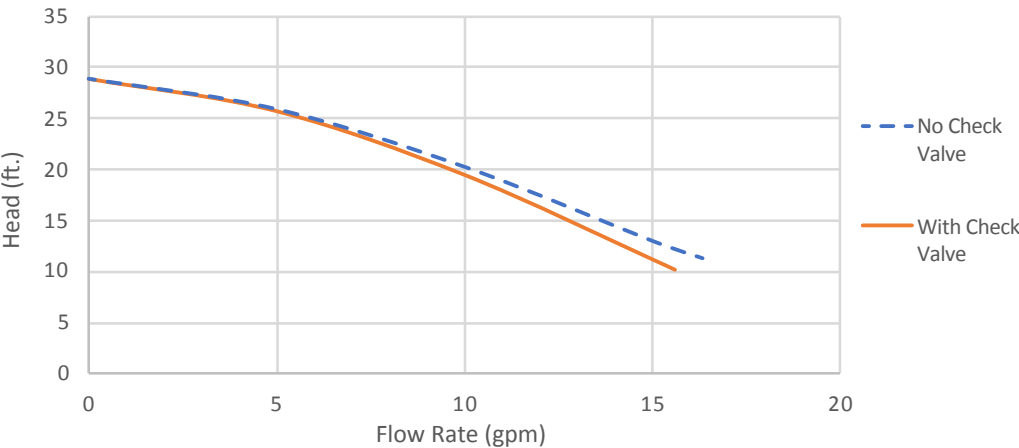

High Head Variable Pump Performance

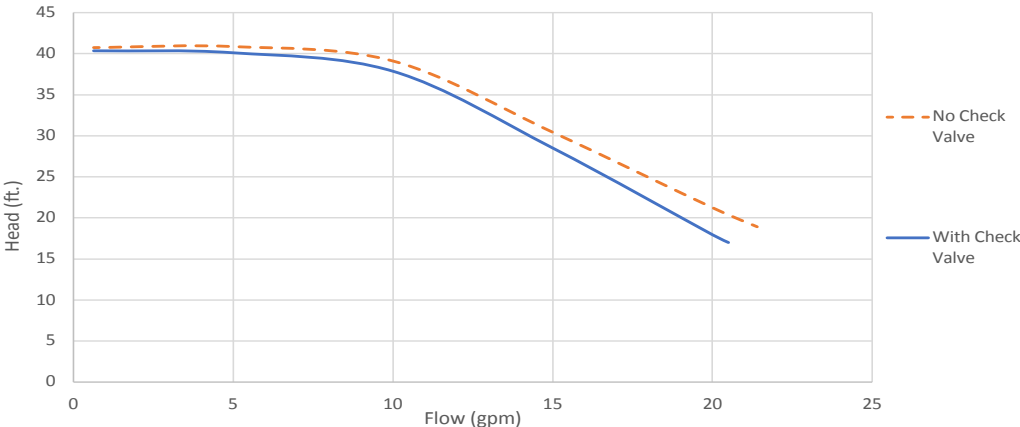

ClimateMaster works continually to improve its products. As a result, the design and specifications of each product at the time of order may be changed without notice and may not be as described herein. Please contact ClimateMaster's Customer Service Department at 1-800-299-9747 for specific information on the current design and specifications. Statements and other information contained herein are not express warranties and do not form the basis of any bargain between the parties, but are merely ClimateMaster's opinion or commendation of its products. The latest version of this document is available at www.climatemaster.com. Engineered and assembled in the USA. © ClimateMaster, Inc. All Rights Reserved 2024

Antifreeze Correction Table

Models:
SE
006-072

EWT (°F)	Antifreeze Type	Antifreeze %	Cooling			Heating		WPD
			Total Cap	Sensible Cap	Watts	Total Cap	Watts	
90	Water	0%	1.000	1.000	1.000	1.000	1.000	1.000
	Ethanol	5%	0.998	0.998	1.002	0.996	0.999	1.025
		10%	0.996	0.996	1.003	0.991	0.997	1.048
		15%	0.994	0.994	1.005	0.987	0.996	1.098
		20%	0.991	0.991	1.006	0.982	0.994	1.142
		25%	0.986	0.986	1.009	0.972	0.991	1.207
		30%	0.981	0.981	1.012	0.962	0.988	1.265
		35%	0.977	0.977	1.015	0.953	0.985	1.312
		40%	0.972	0.972	1.018	0.943	0.982	1.370
		45%	0.966	0.966	1.023	0.931	0.978	1.431
		50%	0.959	0.959	1.027	0.918	0.974	1.494
	Ethylene Glycol	5%	0.998	0.998	1.002	0.996	0.999	1.021
		10%	0.996	0.996	1.003	0.991	0.997	1.040
		15%	0.994	0.994	1.004	0.987	0.996	1.079
		20%	0.991	0.991	1.005	0.982	0.995	1.114
		25%	0.988	0.988	1.008	0.976	0.993	1.146
		30%	0.985	0.985	1.010	0.969	0.990	1.175
		35%	0.982	0.982	1.012	0.963	0.988	1.208
		40%	0.979	0.979	1.014	0.956	0.986	1.243
		45%	0.976	0.976	1.016	0.950	0.984	1.278
		50%	0.972	0.972	1.018	0.943	0.982	1.314
	Methanol	5%	0.997	0.997	1.002	0.993	0.998	1.039
		10%	0.993	0.993	1.004	0.986	0.996	1.075
		15%	0.990	0.990	1.007	0.979	0.994	1.116
		20%	0.986	0.986	1.009	0.972	0.991	1.154
		25%	0.982	0.982	1.012	0.964	0.989	1.189
		30%	0.978	0.978	1.014	0.955	0.986	1.221
		35%	0.974	0.974	1.017	0.947	0.984	1.267
		40%	0.970	0.970	1.020	0.939	0.981	1.310
		45%	0.966	0.966	1.023	0.930	0.978	1.353
		50%	0.961	0.961	1.026	0.920	0.975	1.398
	Propylene Glycol	5%	0.995	0.995	1.003	0.990	0.997	1.065
		10%	0.990	0.990	1.006	0.980	0.994	1.119
		15%	0.986	0.986	1.009	0.971	0.991	1.152
		20%	0.981	0.981	1.012	0.962	0.988	1.182
		25%	0.978	0.978	1.014	0.956	0.986	1.227
		30%	0.975	0.975	1.016	0.950	0.984	1.267
		35%	0.972	0.972	1.018	0.944	0.982	1.312
		40%	0.969	0.969	1.020	0.938	0.980	1.356
		45%	0.965	0.965	1.023	0.929	0.977	1.402
		50%	0.960	0.960	1.026	0.919	0.974	1.450

Table continued on next page

ClimateMaster works continually to improve its products. As a result, the design and specifications of each product at the time of order may be changed without notice and may not be as described herein. Please contact ClimateMaster's Customer Service Department at 1-800-299-9747 for specific information on the current design and specifications. Statements and other information contained herein are not express warranties and do not form the basis of any bargain between the parties, but are merely ClimateMaster's opinion or commendation of its products. The latest version of this document is available at www.climatemaster.com. Engineered and assembled in the USA. © ClimateMaster, Inc. All Rights Reserved 2024

Antifreeze Correction Table

Models:
SE
006-072

Table continued from previous page

EWT (°F)	Antifreeze Type	Antifreeze %	Cooling			Heating		WPD
			Total Cap	Sensible Cap	Watts	Total Cap	Watts	
30	Water	0%	1.000	1.000	1.000	1.000	1.000	1.000
	Ethanol	5%	0.991	0.991	1.006	0.981	0.994	1.140
		10%	0.981	0.981	1.012	0.961	0.988	1.242
		15%	0.973	0.973	1.018	0.944	0.983	1.295
		20%	0.964	0.964	1.024	0.927	0.977	1.343
		25%	0.959	0.959	1.028	0.917	0.974	1.363
		30%	0.954	0.954	1.031	0.907	0.970	1.383
		35%	0.949	0.949	1.035	0.897	0.967	1.468
		40%	0.944	0.944	1.038	0.887	0.964	1.523
		45%	0.940	0.940	1.041	0.880	0.962	1.580
	50%	0.936	0.936	1.043	0.872	0.959	1.639	
	Ethylene Glycol	5%	0.997	0.997	1.002	0.993	0.998	1.040
		10%	0.993	0.993	1.004	0.986	0.996	1.075
		15%	0.990	0.990	1.006	0.980	0.994	1.122
		20%	0.987	0.987	1.008	0.973	0.992	1.163
		25%	0.983	0.983	1.011	0.966	0.990	1.195
		30%	0.979	0.979	1.013	0.958	0.987	1.225
		35%	0.976	0.976	1.016	0.951	0.985	1.279
		40%	0.972	0.972	1.018	0.943	0.982	1.324
		45%	0.969	0.969	1.021	0.937	0.980	1.371
	50%	0.966	0.966	1.023	0.930	0.978	1.419	
	Methanol	5%	0.995	0.995	1.004	0.989	0.997	1.069
		10%	0.989	0.989	1.007	0.978	0.993	1.127
		15%	0.984	0.984	1.011	0.968	0.990	1.164
		20%	0.979	0.979	1.014	0.957	0.986	1.197
		25%	0.975	0.975	1.017	0.949	0.984	1.216
		30%	0.971	0.971	1.019	0.941	0.981	1.235
		35%	0.967	0.967	1.022	0.933	0.979	1.286
		40%	0.963	0.963	1.025	0.924	0.976	1.323
		45%	0.959	0.959	1.028	0.917	0.974	1.360
	50%	0.955	0.955	1.030	0.910	0.971	1.399	
	Propylene Glycol	5%	0.995	0.995	1.004	0.989	0.997	1.071
		10%	0.989	0.989	1.007	0.978	0.993	1.130
		15%	0.985	0.985	1.010	0.968	0.990	1.206
		20%	0.980	0.980	1.013	0.958	0.987	1.270
		25%	0.974	0.974	1.017	0.947	0.983	1.359
		30%	0.968	0.968	1.021	0.935	0.979	1.433
		35%	0.963	0.963	1.025	0.924	0.976	1.522
		40%	0.957	0.957	1.029	0.913	0.972	1.614
		45%	0.949	0.949	1.034	0.898	0.967	1.712
	50%	0.941	0.941	1.039	0.882	0.962	1.816	

ClimateMaster works continually to improve its products. As a result, the design and specifications of each product at the time of order may be changed without notice and may not be as described herein. Please contact ClimateMaster's Customer Service Department at 1-800-299-9747 for specific information on the current design and specifications. Statements and other information contained herein are not express warranties and do not form the basis of any bargain between the parties, but are merely ClimateMaster's opinion or commendation of its products. The latest version of this document is available at www.climatemaster.com. Engineered and assembled in the USA. © ClimateMaster, Inc. All Rights Reserved 2024

Water Pressure Drop Adder for Options: Correction Tables

Models:
SE
006-072

System Pressure Drop Valve

Model	GPM	Low System Pressure Drop Valve (Adders)					High System Pressure Drop Valve (Adders)				
		CV	Close Off	MOPD	PSI	FT	CV	Close Off	MOPD	PSI	FT
SE006	1.00	4.9		150	0.04	0.10					
	1.50	4.9		150	0.09	0.22					
	2.00	4.9		150	0.17	0.38					
SE009	1.40	4.9		150	0.08	0.19					
	2.10	4.9		150	0.18	0.42					
	2.80	4.9		150	0.33	0.75					
SE012	1.80	4.9		150	0.13	0.31					
	2.60	4.9		150	0.28	0.65					
	3.50	4.9		150	0.51	1.18					
SE018	2.80	10.3		125	0.07	0.16					
	4.10	10.3		125	0.16	0.37					
	5.50	10.3		125	0.29	0.66					
SE024	3	4.7	200	30	0.41	0.94	4.7	200	30	0.41	0.94
	4.5				0.92	2.12				0.92	2.12
	6				1.63	3.76				1.63	3.76
SE036	4.5	7.4	200	30	0.37	0.85	4.7	200	30	0.92	2.12
	6.8				0.84	1.95				2.09	4.84
	9				1.48	3.42				3.67	8.47
SE048	6	10	200	30	0.36	0.83	4.7	200	30	1.63	3.76
	9				0.81	1.87				3.67	8.47
	12				1.44	3.33				6.52	15.06
SE060	7.5	19	200	30	0.16	0.36	7.4	200	30	1.03	2.37
	11.3				0.35	0.82				2.33	5.39
	15				0.62	1.44				4.11	9.49
SE072	8.5	19	200	30	0.20	0.46	7.4	200	30	1.32	3.05
	12.8				0.45	1.05				2.99	6.91
	17				0.80	1.85				5.28	12.19

ClimateMaster works continually to improve its products. As a result, the design and specifications of each product at the time of order may be changed without notice and may not be as described herein. Please contact ClimateMaster's Customer Service Department at 1-800-299-9747 for specific information on the current design and specifications. Statements and other information contained herein are not express warranties and do not form the basis of any bargain between the parties, but are merely ClimateMaster's opinion or commendation of its products. The latest version of this document is available at www.climatemaster.com. Engineered and assembled in the USA. © ClimateMaster, Inc. All Rights Reserved 2024

Tranquility (SE) Series

Model (SE)	006	009	012	018	024	036	048	60	072
Compressor (1 each)	Scroll								
Factory Charge R-454B - (oz.)	19	26	27	40	34	43	59	102	109
Refrigerant Leak Detection System	O	O	O	O	O	O	O	R	R
Number of Sensors	2	2	2	2	2	2	2	2	2
Water Connection Size									
Source FPT	1/2"	1/2"	1/2"	3/4"	3/4"	3/4"	1"	1"	1"
System Water Volume (gallons) ¹	0.170	0.290	0.450	0.560	0.323	0.738	0.890	0.939	0.939
Vertical									
Filter Standard - 1" Throwaway	16 x 20	16 x 20	16 x 20	24 x 24	28 x 24	28 x 29.5	32 x 29.5	36 x 29.5	36 x 29.5
Weight - Operating (lbs.)	136	156	160	257	298	359	448	475	475
Weight - Packaged (lbs.)	146	166	170	267	308	369	458	485	485
Horizontal									
Filter Standard - 1" Throwaway	16 X 20	16 X 20	16 X 20	2 - 18 X 18	2 - 18 x 18	1 - 12 x 20 1 - 20 x 25	1 - 18 x 20 1 - 20 x 24	2 - 20 x 24	2 - 20 x 24
Weight - Operating (lbs.)	136	156	160	257	298	359	448	475	475
Weight - Packaged (lbs.)	146	166	170	267	308	369	458	485	485
Downflow									
Filter Standard - 1" Throwaway	16 x 20	16 x 20	16 x 20	24 x 24	28 x 24	28 x 29.5	32 x 29.5	36 x 29.5	36 x 29.5
Weight - Operating (lbs.)	136	156	160	257	298	359	448	475	475
Weight - Packaged (lbs.)	146	166	170	267	308	369	458	485	485
Hot Water Generator									
FPT	-	-	-	-	1/2"	1/2"	1/2"	1/2"	1/2"
Weight - HWG Adder (lbs.)	-	-	-	-	+15	+15	+15	+15	+15

Notes:

- All dimensions displayed above are in inches unless otherwise marked.
 - All units have TXV expansion device and 1/2-inch and 3/4-inch electrical knockouts.
 - 575V fan motors are two speed.
 - FPT=Female Pipe Thread
 - The standard Condensate Drain Connection is rubber coupling that couples to 3/4-inch schedule 40/80 PVC.
 - The optional Stainless Steel Condensate Drain Connection is 3/4-inch FPT.
 - O = Optional, R = Required
1. Volume without water options.

Unit Maximum Water Working Pressure

Options	Max Pressure PSIG [kPa]
Base Unit	300 [2,068]
Internal Secondary Pump (ISP)	145 [999]
Internal Motorized Water Valve (MWV)	300 [2,068]
Internal Auto Flow Valve	300 [2,068]

- Use the lowest maximum pressure rating when multiple options are combined.

Horizontal Dimensional Data

Models:
SE
006-072

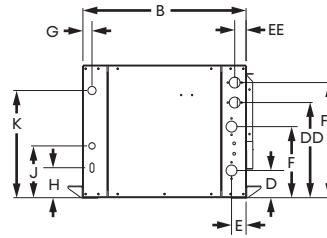
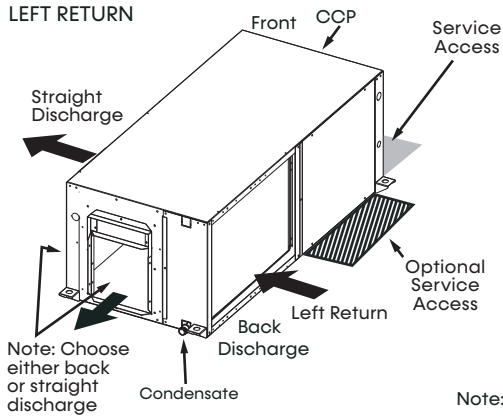

Note: Blower service panel requires 2-foot service access

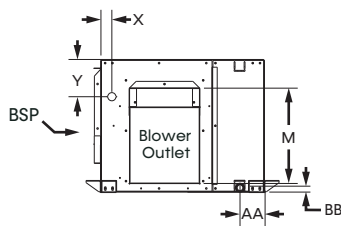
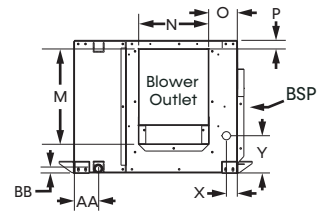
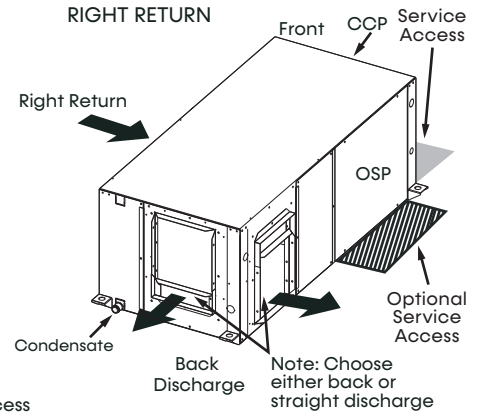

Left Return Back Discharge

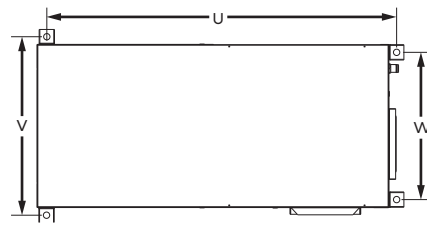

Left Return Straight Discharge

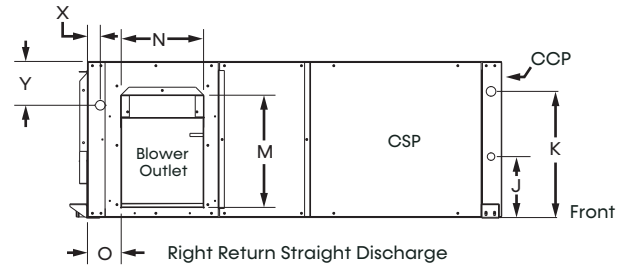
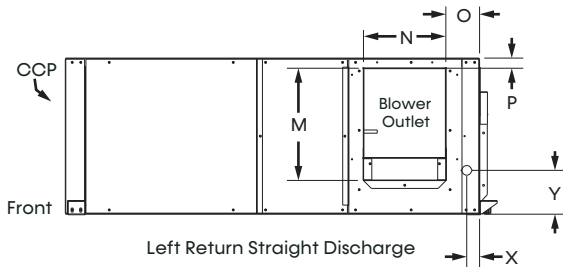

Right Return Straight Discharge

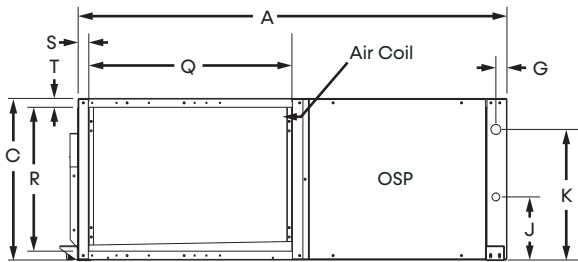

Left Return Left View
Air Coil Opening

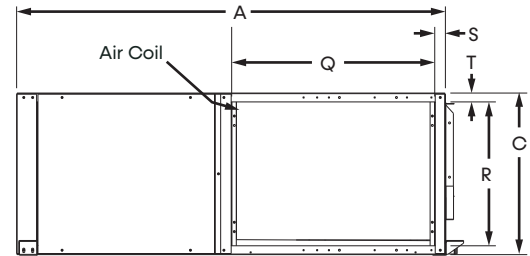

Right Return Right View
Air Coil Opening

Notes:

1. While clear access to all removable panels is not required, installer should take care to comply with all building codes and allow adequate clearance for future field service.
2. Units come standard with air filter rails. For duct connections, order optional filter frames. See product options decoder for details. You can convert filter rails in the field with an accessory air filter frame kit. Please see the accessory submittal for details.
3. Discharge flange and hanger brackets are factory installed.
4. Condensate connection is 3/4-inch MPT.
5. Blower service panel requires 2-foot service access.
6. Blower service access is through back panel on straight discharge units or through panel opposite air coil on back discharge units.
7. Water connections for optional hot water generator are 1-inch swivels.
8. OSP are removable panels that provide additional access to the units interior. Clear access to OSP panels is not required and they are not to be used in place of the mandatory CCP and BSP panels.

Legend:

- CCP = Control/Compressor Access
- BSP = Blower Service Panel
- OSP = Optional Service Panel (not required)

ClimateMaster works continually to improve its products. As a result, the design and specifications of each product at the time of order may be changed without notice and may not be as described herein. Please contact ClimateMaster's Customer Service Department at 1-800-299-9747 for specific information on the current design and specifications. Statements and other information contained herein are not express warranties and do not form the basis of any bargain between the parties, but are merely ClimateMaster's opinion or commendation of its products. The latest version of this document is available at www.climatemaster.com. Engineered and assembled in the USA. © ClimateMaster, Inc. All Rights Reserved 2024

Horizontal Service Access

Models:
SE
006-072

Left Return Back Discharge

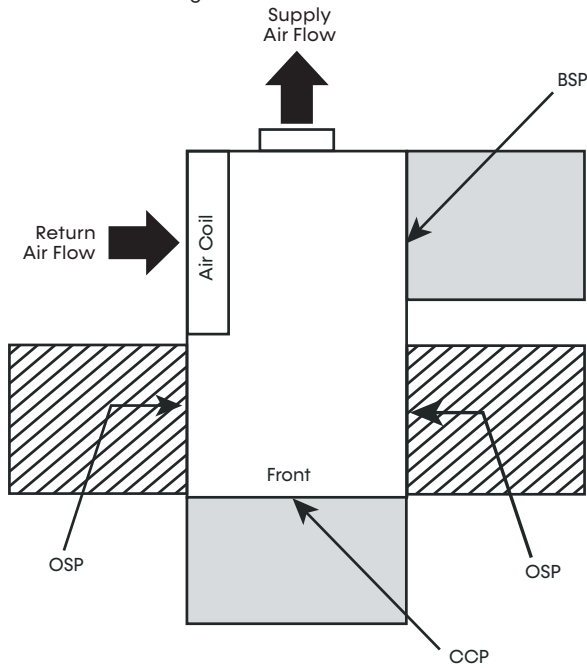

Right Return Back Discharge

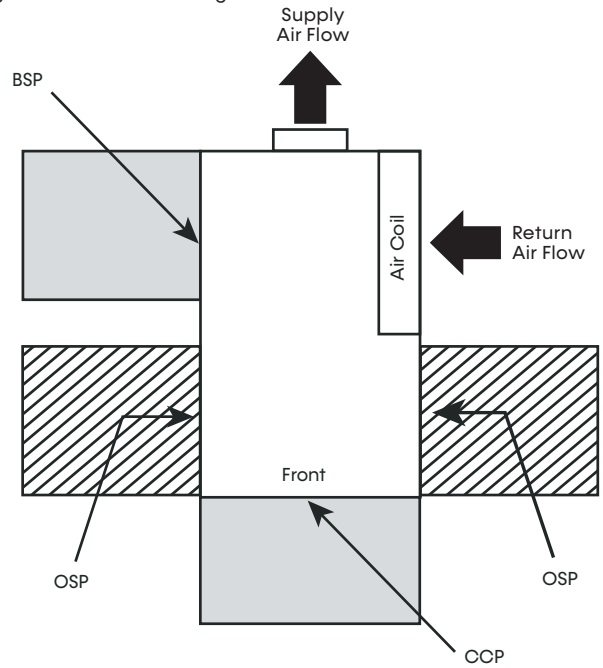

Left Return Straight Discharge

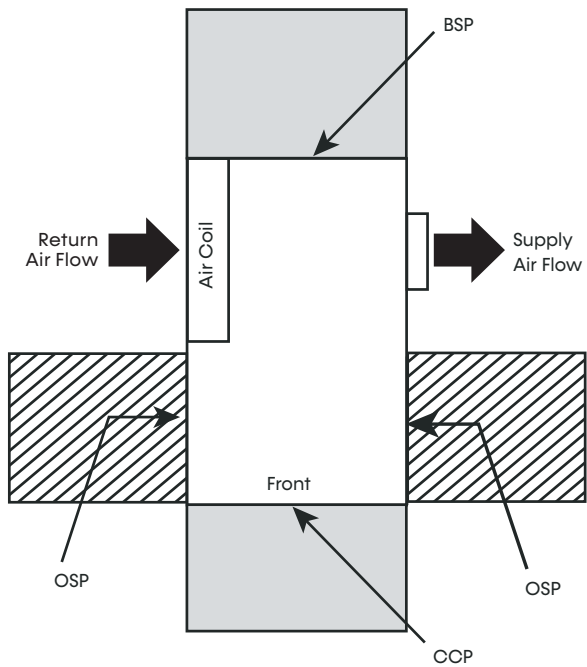

Right Return Straight Discharge

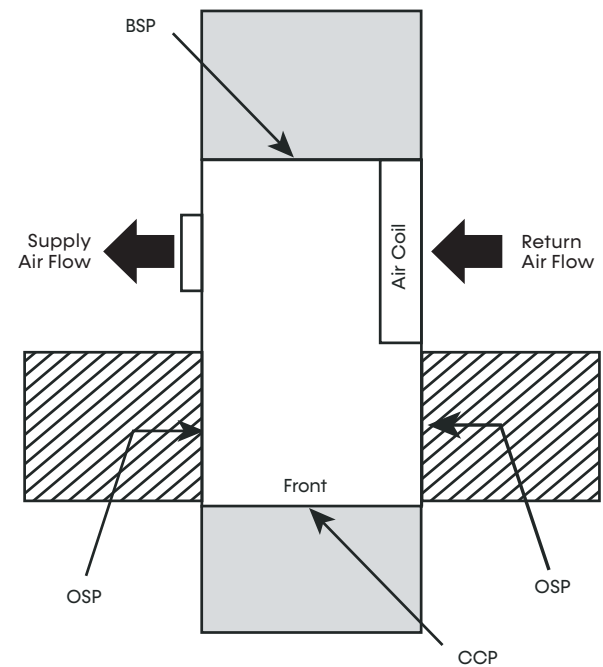

Notes:

1. While clear access to all removable panels is not required, installer should take care to comply with all building codes and allow adequate clearance for future field service.
2. CCP and BSP requires 2-feet of service access.
3. Blower service access is through back panel on straight discharge units or through panel opposite air coil on back discharge units.
4. OSP are removable panels that provide additional access to the units interior. Clear access to OSP panels is not required and they are not to be used in place of the mandatory CCP and BSP panels.

- = Mandatory Service Access 2-foot (61 cm)
- = Optional Service Access 2-foot (61 cm)

Legend:

- CCP = Control/Compressor Access
- BSP = Blower Service Panel
- OSP = Optional Service Panel (not required)

ClimateMaster works continually to improve its products. As a result, the design and specifications of each product at the time of order may be changed without notice and may not be as described herein. Please contact ClimateMaster's Customer Service Department at 1-800-299-9747 for specific information on the current design and specifications. Statements and other information contained herein are not express warranties and do not form the basis of any bargain between the parties, but are merely ClimateMaster's opinion or commendation of its products. The latest version of this document is available at www.climatemaster.com. Engineered and assembled in the USA. © ClimateMaster, Inc. All Rights Reserved 2024

Vertical Upflow Dimensional Data

Models:
SE
006-072

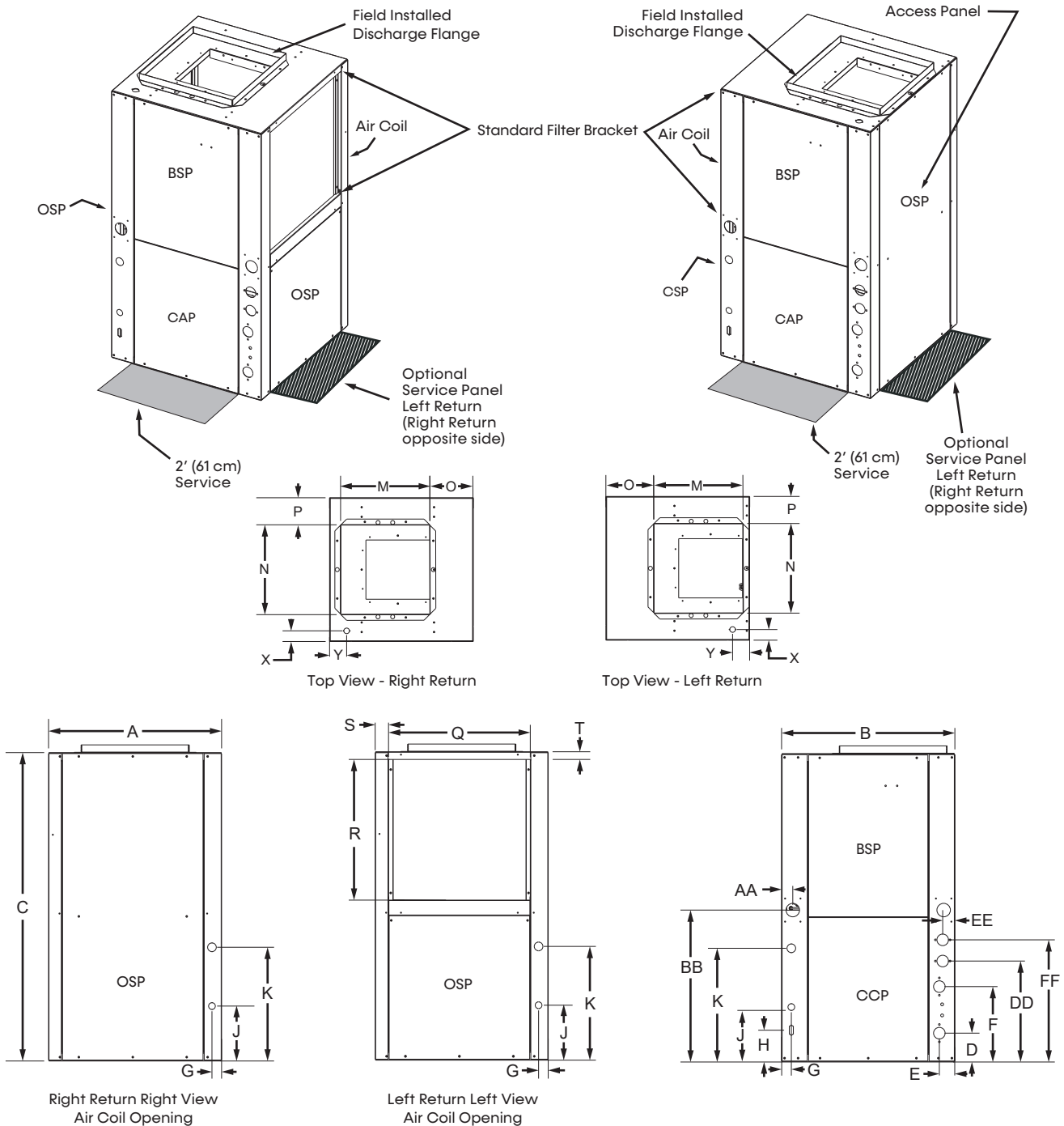

Notes:

1. While clear access to all removable panels is not required, installer should take care to comply with all building codes and allow adequate clearance for future field service.
2. Front and Side access is preferred for service access. However, all components may be serviced from the front access panel if side access is not available.
3. Discharge flange is field installed.
4. Condensate Connection is 3/4-inch MPT.
5. Water connections for optional hot water generator are 1-inch swivels.
6. Units come standard with air filter rails. For duct connections, optional filter frames should be ordered. See product options decoder for details. Filter rails can be converted in the field with an accessory air filter frame kit. Please see the accessory submittal for details.

Legend:

- CCP = Control/Compressor Access
- BSP = Blower Service Panel
- OSP = Optional Service Panel (not required)

ClimateMaster works continually to improve its products. As a result, the design and specifications of each product at the time of order may be changed without notice and may not be as described herein. Please contact ClimateMaster's Customer Service Department at 1-800-299-9747 for specific information on the current design and specifications. Statements and other information contained herein are not express warranties and do not form the basis of any bargain between the parties, but are merely ClimateMaster's opinion or commendation of its products. The latest version of this document is available at www.climatemaster.com. Engineered and assembled in the USA. © ClimateMaster, Inc. All Rights Reserved 2024

Vertical Downflow Dimensional Data

Models:
SE
006-072

Left Downflow

Right Downflow

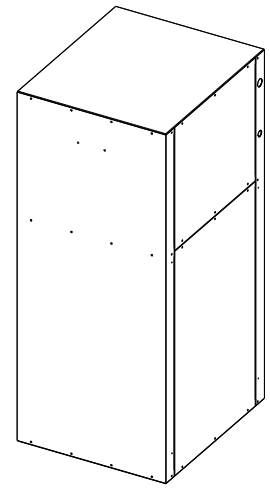
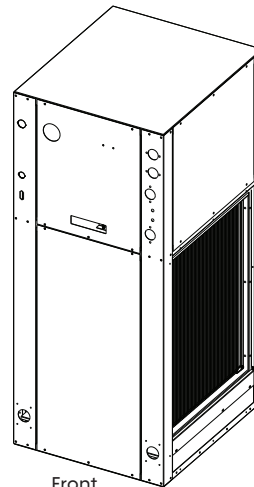
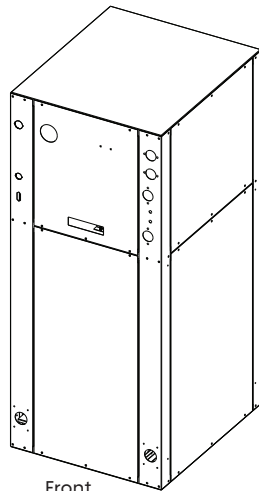
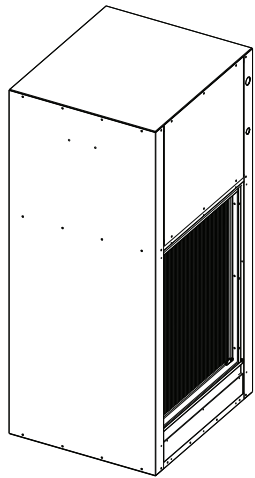

ISO Back

Front

Front

ISO Back

Left

Right

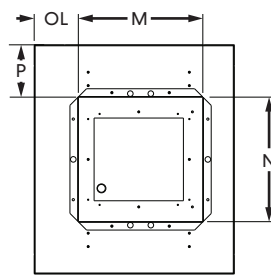
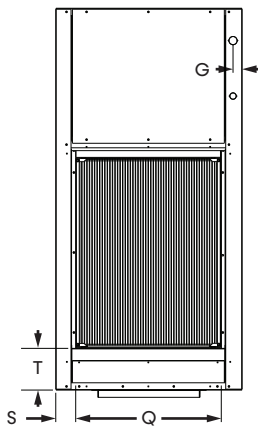

Front

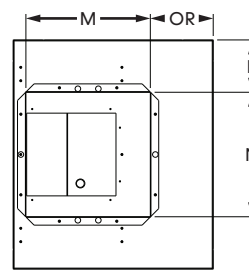

Bottom

Bottom

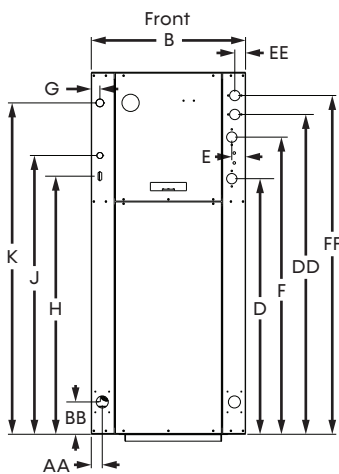
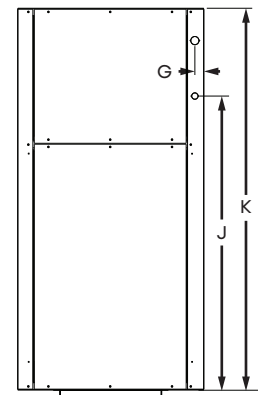

Right

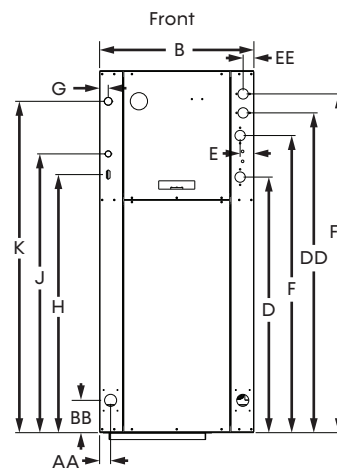
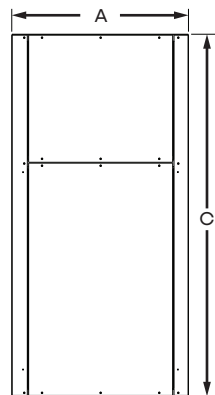

Left

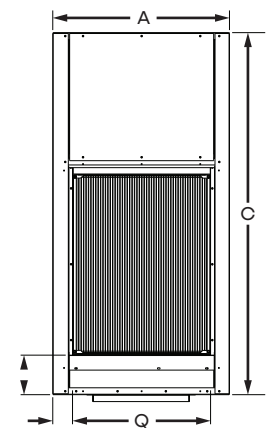

ClimateMaster works continually to improve its products. As a result, the design and specifications of each product at the time of order may be changed without notice and may not be as described herein. Please contact ClimateMaster's Customer Service Department at 1-800-299-9747 for specific information on the current design and specifications. Statements and other information contained herein are not express warranties and do not form the basis of any bargain between the parties, but are merely ClimateMaster's opinion or commendation of its products. The latest version of this document is available at www.climatemaster.com. Engineered and assembled in the USA. © ClimateMaster, Inc. All Rights Reserved 2024

Vertical Units

Left Return

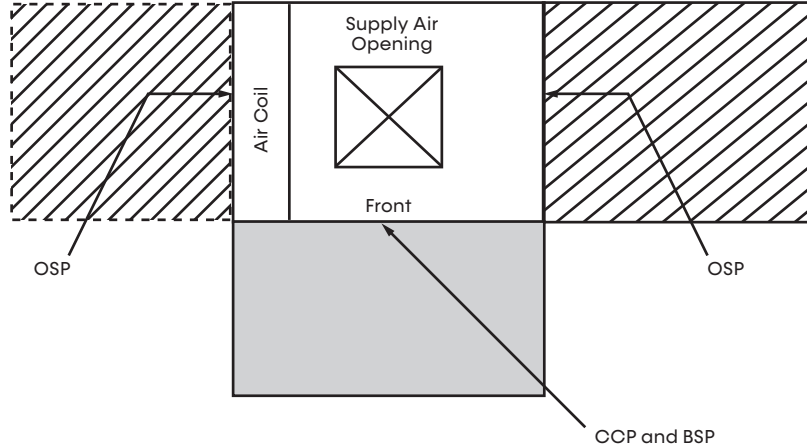

Right Return

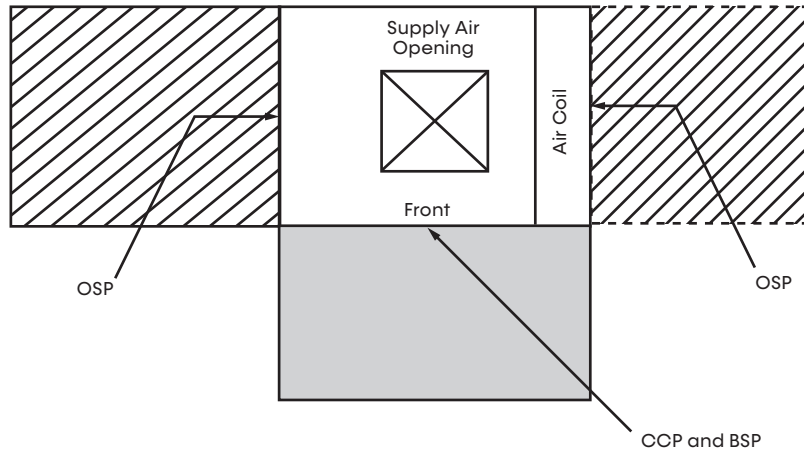

Notes:

1. While clear access to all removable panels is not required, installer should take care to comply with all building codes and allow adequate clearance for future field service.
2. Front and side access is preferred for service access. However, all components may be serviced from the front access panel if side access is not available.
3. OSP are removable panels that provide additional access to the units interior. Clear access to OSP panels is not required and they are not to be used in place of the mandatory CCP and BSP panels.
4. Top supply air is shown, the same clearances apply to bottom supply air units.

 = Mandatory Service Access 2-foot (61 cm)

 = Optional Service Access 2-foot (61 cm)

Legend:

CCP = Control/Compressor Access

BSP = Blower Service Panel

OSP = Optional Service Panel (not required)

Dimensional Data

Models:
SE
006-072

Cabinet Dimensions (inch)

Model	Cabinet Config	Depth/Length	Width	Height
		A	B	C
SE006-SE012	H	43.1	22.4	17.3
	V	21.6	22.4	34.5
SE018	H	62.2	22.4	19.3
	V	25.6	22.4	44.6
	D	25.6	22.4	48.4
SE024	H	62.2	22.4	19.3
	V	25.6	22.4	48.5
	D	25.6	22.4	52.4
SE036	H	71.2	25.4	21.3
	V	30.6	25.4	50.5
	D	30.6	25.4	54.3
SE048	H	76.2	25.4	21.3
	V	30.6	25.4	54.5
	D	30.6	25.4	58.3
SE060-SE072	H	81.2	25.4	21.3
	V	30.6	25.4	58.5
	D	30.6	25.4	62.3

Electrical Knockouts (inch)

Model	Cabinet Config	H	Low Voltage	High Voltage	G
			J KO 1/2"	K KO 3/4"	
SE006-SE012	H	1.6	3.8	6.3	1.1
	V	1.6	3.8	6.3	1.2
SE018	H	1.6	3.6	6.1	1.1
	V	1.6	3.6	6.1	1.2
	D	1.6	3.6	6.1	1.1
SE024	H	4.1	3.6	8.6	1.3
	V	4.1	3.6	8.6	1.3
	D	37.4	40.4	47.9	1.3
SE036	H	4.1	3.6	8.6	1.3
	V	4.1	3.6	8.6	1.3
	D	37.4	40.3	50.0	1.3
SE048	H	4.1	3.6	8.6	1.3
	V	4.1	3.6	8.6	1.3
	D	41.3	48.4	54.0	1.3
SE060-SE072	H	4.1	3.6	8.6	1.3
	V	4.1	3.6	8.6	1.3
	D	45.4	48.4	58.1	1.3

Shipping Weights and Water Connections (inch)

Model	Cabinet Config	Shipping Dimensions			Water Connections										Condensate Drain Pan				
		Depth/Length	Width	Height	Water In		Water Out		Water In/Out		HWG In		HWG Out		AA	BB	Condensate Drain Pan Fitting ³		
		A	B	C	D	E	F	E	Com ¹	Res ²	DD	EE	FF	EE					
SE006-SE012	H	43.1	22.4	17.3	3.7	1.6	9.7	1.6	1/2"								0.8	3.3	3/4" FPT
	V	21.6	22.4	34.5	3.7	1.7	9.7	1.7	1/2"								7.4	1.7	3/4" FPT
SE018	H	62.2	22.4	19.3	2.1	1.6	10.0	1.6	3/4"			13.9	0.6	16.9	0.6	0.8	3.3	3/4" FPT	
	V	25.6	22.4	44.6	2.1	1.7	10.0	1.7	3/4"			13.9	7.8	16.9	7.8	7.4	1.7	3/4" FPT	
	D	25.6	22.4	48.4	17.2	1.6	9.3	1.6	3/4"			5.4	3.6	2.4	3.6	3.6	1.6	3/4" FPT	
SE024	H	67.5	28.4	23.7	3.9	1.7	8.4	1.7	3/4"	3/4"	13.9	1.6	16.9	1.6	3.3	1.5	3/4" FPT		
	V	28.0	31.0	52.9	3.9	1.6	8.4	1.6	3/4"	3/4"	13.9	1.6	16.9	1.6	1.4	20.0	3/4" FPT		
	D	28.0	31.0	56.8	37.0	2.0	43.0	2.0	3/4"	3/4"	46.4	1.6	49.1	1.6	1.6	4.7	3/4" FPT		
SE036	H	76.5	31.4	25.7	3.9	2.0	8.4	2.0	3/4"	3/4"	15.6	1.6	18.9	1.6	3.3	3.4	3/4" FPT		
	V	31.0	36.0	54.9	3.9	2.0	8.4	2.0	3/4"	3/4"	15.6	1.6	18.9	1.6	2.0	22.3	3/4" FPT		
	D	31.0	36.0	58.6	37.0	2.0	44.3	2.0	3/4"	3/4"	49.0	1.6	51.8	1.6	1.6	4.7	3/4" FPT		
SE048	H	81.5	31.4	25.7	3.9	2.0	8.4	2.0	1"	1"	15.6	1.6	18.9	1.6	3.3	3.4	3/4" FPT		
	V	31.0	36.0	58.9	3.9	2.0	8.4	2.0	1"	1"	15.6	1.6	18.9	1.6	2.0	22.3	3/4" FPT		
	D	31.0	36.0	62.6	41.0	2.0	48.3	2.0	1"	1"	53.0	1.6	55.7	1.6	1.6	4.7	3/4" FPT		
SE060-SE072	H	86.5	31.4	25.7	3.9	2.0	8.4	2.0	1"	1"	15.6	1.6	18.9	1.6	3.3	3.4	3/4" FPT		
	V	31.0	36.0	62.9	3.9	2.0	8.4	2.0	1"	1"	15.6	1.6	18.9	1.6	2.0	21.7	3/4" FPT		
	D	31.0	36.0	66.6	45.0	2.0	52.3	2.0	1"	1"	56.9	1.6	59.7	1.6	1.6	4.7	3/4" FPT		

Notes:

- Commercial water connections are Female Pipe Thread (FPT) fittings
- Residential water connections are 1-inch swivel connections
- See PDF drawings for reference

ClimateMaster works continually to improve its products. As a result, the design and specifications of each product at the time of order may be changed without notice and may not be as described herein. Please contact ClimateMaster's Customer Service Department at 1-800-299-9747 for specific information on the current design and specifications. Statements and other information contained herein are not express warranties and do not form the basis of any bargain between the parties, but are merely ClimateMaster's opinion or commendation of its products. The latest version of this document is available at www.climatemaster.com. Engineered and assembled in the USA. © ClimateMaster, Inc. All Rights Reserved 2024

Dimensional Data

Models:
SE
006-072

Discharge and Return Connections (inch)

Model	Cabinet Config	Discharge Connection Duct Flange Installed					Return Connection Using Return Air Opening			
		Supply Height	Supply Width	O		P	Return Width	Return Height	S	T
				OL (Left Return)	OR (Right Return)					
M	N									
SE006-SE012	H	9.0	9.0	5.3		4.1	17.1	15.3	2.1	1.0
	V	9.0	9.0	6.7		6.3	17.1	15.3	1.0	1.7
SE018	H	15.5	12.5	3.6	3.6	2.0	28.1	17.3	6.2	1.0
	V	14.0	14.0	7.2	7.2	5.8	21.1	23.7	1.0	1.7
	D	10.1	9.1	6.7	6.7	8.4	21.1	23.7	21.2	1.7
SE024	H	15.5	12.5	3.8	3.8	2.0	32.1	17.3	2.3	1.0
	V	14.0	14.0	6.8	6.7	5.8	21.2	27.7	2.3	1.0
	D	14.0	14.0	4.9	2.8	7.2	21.2	27.7	2.3	1.0
SE036	H	19.0	17.5	2.9	2.9	1.2	36.1	19.3	2.3	1.0
	V	18.0	18.0	2.0	5.3	6.3	26.1	27.7	2.3	1.0
	D	18.0	18.0	5.4	3.0	6.3	26.1	27.7	2.3	1.0
SE048	H	19.0	17.5	3.0	3.0	1.2	41.1	19.3	2.3	1.0
	V	18.0	18.0	3.0	5.3	6.3	26.1	31.7	2.3	1.0
	D	18.0	18.0	5.4	3.0	6.3	26.1	31.7	2.3	1.0
SE060-SE072	H	19.0	17.5	3.0	3.0	1.2	46.1	19.3	2.3	1.0
	V	18.0	18.0	3.0	5.3	6.3	26.1	35.7	2.3	1.0
	D	18.0	18.0	5.4	3.0	6.3	26.1	35.7	2.3	1.0

Corner Weights (lb)

Model	Left - Front	Right - Front	Left - Back	Right/Back
SE006-SE012	56.0	34.0	37.0	33.0
SE018	78.1	65.6	66.2	47.5
SE024	68.0	56.0	42.0	42.0
SE036	76.0	63.0	47.0	47.0
SE048	98.0	81.0	60.0	60.0
SE060-SE072	103.0	85.0	63.0	63.0

Hanger Dimensions (inch)

Model	Cabinet Config	Unit Hanger Detail		
		U	V	W
SE006-SE012	H	43.1	24.5	20.3
SE018	H	62.1	24.5	20.3
SE024	H	122.9	62.5	51.6
SE036	H	135.4	62.5	59.2
SE048	H	172.7	70.1	59.2
SE060-SE072	H	172.7	70.1	59.2

ClimateMaster works continually to improve its products. As a result, the design and specifications of each product at the time of order may be changed without notice and may not be as described herein. Please contact ClimateMaster's Customer Service Department at 1-800-299-9747 for specific information on the current design and specifications. Statements and other information contained herein are not express warranties and do not form the basis of any bargain between the parties, but are merely ClimateMaster's opinion or commendation of its products. The latest version of this document is available at www.climatemaster.com. Engineered and assembled in the USA. © ClimateMaster, Inc. All Rights Reserved 2024

Dimensional Data

Models:
SE
006-072

Cabinet Dimensions (cm)

Model	Cabinet Config	Depth/Length	Width	Height
		A	B	C
SE006-SE012	H	109.5	56.9	43.9
	V	54.9	56.9	87.6
SE018	H	158.0	56.9	49.0
	V	65.0	56.9	113.3
	D	65.0	56.9	122.9
SE024	H	158.0	56.9	49.0
	V	65.0	56.9	123.2
	D	65.0	56.9	133.1
SE036	H	180.8	64.5	54.1
	V	77.7	64.5	128.3
	D	77.7	64.5	137.8
SE048	H	193.5	64.5	54.1
	V	77.7	64.5	138.4
	D	77.7	64.5	148.0
SE060-SE072	H	206.2	64.5	54.1
	V	77.7	64.5	148.6
	D	77.7	64.5	158.1

Electrical Knockouts (cm)

Model	Cabinet Config	H	Low Voltage	High Voltage	G
			J KO 1/2"	K KO 3/4"	
SE006-SE012	H	4.1	9.7	16.0	2.8
	V	4.1	9.7	16.0	3.0
SE018	H	4.1	9.1	15.5	2.8
	V	4.1	9.1	15.5	3.0
	D	4.1	9.1	15.5	2.8
SE024	H	10.4	9.1	21.8	3.2
	V	10.4	9.1	21.8	3.2
	D	95.0	102.7	121.8	3.2
SE036	H	10.4	9.1	21.8	3.2
	V	10.4	9.1	21.8	3.2
	D	95.0	102.3	127.0	3.2
SE048	H	10.4	9.1	21.8	3.2
	V	10.4	9.1	21.8	3.2
	D	104.9	122.9	137.2	3.2
SE060-SE072	H	10.4	9.1	21.8	3.2
	V	10.4	9.1	21.8	3.2
	D	115.3	122.9	147.4	3.2

Shipping Weights and Water Connections (cm)

Model	Cabinet Config	Shipping Dimensions			Water Connections										Condensate Drain Pan				
		Depth/Length	Width	Height	Water In		Water Out		Water In/Out		HWG In		HWG Out		AA	BB	Condensate Drain Pan Fitting ³		
		A	B	C	D	E	F	E	Com ¹	Res ²	DD	EE	FF	EE					
SE006-SE012	H	109.5	56.9	43.9	9.4	4.1	24.6	4.1	1/2"								2.0	8.3	3/4" FPT
	V	54.9	56.9	87.6	9.4	4.3	24.6	4.3	1/2"								18.8	4.3	3/4" FPT
SE018	H	158.0	56.9	49.0	5.3	4.1	25.4	4.1	3/4"			35.3	1.5	42.9	1.5		2.0	8.3	3/4" FPT
	V	65.0	56.9	113.3	5.3	4.3	25.4	4.3	3/4"			35.3	19.8	42.9	19.8		18.8	4.3	3/4" FPT
	D	65.0	56.9	122.9	43.7	4.1	23.6	4.1	3/4"			13.7	9.1	6.1	9.1		9.1	4.1	3/4" FPT
SE024	H	171.5	72.1	60.1	9.9	4.3	21.3	4.3	3/4"	3/4"		35.3	4.1	42.9	4.1		8.5	3.8	3/4" FPT
	V	71.1	78.7	134.3	9.9	4.1	21.3	4.1	3/4"	3/4"		35.3	4.1	42.9	4.1		3.6	50.7	3/4" FPT
	D	71.1	78.7	144.3	94.0	5.1	109.3	5.1	3/4"	3/4"		117.9	4.0	124.8	4.1		4.1	11.9	3/4" FPT
SE036	H	194.3	79.7	65.2	9.9	5.0	21.3	5.0	3/4"	3/4"		39.6	4.1	48.0	4.1		8.3	8.6	3/4" FPT
	V	78.7	91.4	139.4	9.9	5.0	21.3	5.0	3/4"	3/4"		39.6	4.1	48.0	4.1		5.0	56.6	3/4" FPT
	D	78.7	91.4	148.9	94.0	5.1	112.4	5.1	3/4"	3/4"		124.5	4.1	131.4	4.1		4.1	11.9	3/4" FPT
SE048	H	207.0	79.7	65.2	9.9	5.0	21.3	5.0	1"	1"		39.6	4.1	48.0	4.1		8.3	8.6	3/4" FPT
	V	78.7	91.4	149.6	9.9	5.0	21.3	5.0	1"	1"		39.6	4.1	48.0	4.1		5.0	56.6	3/4" FPT
	D	78.7	91.4	159.1	104.0	5.0	122.7	5.0	1"	1"		134.5	4.1	141.4	4.1		4.1	11.9	3/4" FPT
SE060-SE072	H	219.7	79.7	65.2	9.9	5.0	21.3	5.0	1"	1"		39.6	4.1	48.0	4.1		8.3	8.6	3/4" FPT
	V	78.7	91.4	159.7	9.9	5.0	21.3	5.0	1"	1"		39.6	4.1	48.0	4.1		5.0	55.1	3/4" FPT
	D	78.7	91.4	169.2	114.4	5.0	132.8	5.0	1"	1"		144.6	4.1	151.6	4.1		4.1	11.9	3/4" FPT

Notes:

- Commercial water connections are Female Pipe Thread (FPT) fittings
- Residential water connections are 1-inch swivel connections
- See PDF drawings for reference

ClimateMaster works continually to improve its products. As a result, the design and specifications of each product at the time of order may be changed without notice and may not be as described herein. Please contact ClimateMaster's Customer Service Department at 1-800-299-9747 for specific information on the current design and specifications. Statements and other information contained herein are not express warranties and do not form the basis of any bargain between the parties, but are merely ClimateMaster's opinion or commendation of its products. The latest version of this document is available at www.climatemaster.com. Engineered and assembled in the USA. © ClimateMaster, Inc. All Rights Reserved 2024

Dimensional Data

Models:
SE
006-072

Discharge and Return Connections (cm)

Model	Cabinet Config	Discharge Connection Duct Flange Installed					Return Connection Using Return Air Opening			
		Supply Height	Supply Width	O		P	Return Width	Return Height	S	T
				OL (Left Return)	OR (Right Return)					
SE006-SE012	H	22.9	22.9	13.5		10.4	43.4	38.9	5.3	2.5
	V	22.9	22.9	17.0		16.0	43.4	38.9	2.5	4.3
SE018	H	39.4	31.8	9.1	9.1	5.1	71.4	43.9	15.7	2.5
	V	35.6	35.6	18.3	18.3	14.7	53.6	60.2	2.5	4.3
	D	25.7	23.1	17.0	17.0	21.3	53.6	60.2	53.8	4.3
SE024	H	39.4	31.8	9.5	9.5	5.1	81.5	43.9	5.8	2.5
	V	35.6	35.6	17.3	17.0	14.7	53.8	70.4	5.8	2.5
	D	35.6	35.6	12.4	7.1	18.3	53.8	70.4	5.8	2.5
SE036	H	48.3	44.5	7.5	7.5	3.0	91.7	49.0	5.8	2.5
	V	45.7	45.7	5.1	13.5	16.0	66.3	70.4	5.8	2.5
	D	45.7	45.7	13.7	7.6	16.0	66.3	70.4	5.8	2.5
SE048	H	48.3	44.5	7.6	7.6	3.0	104.4	49.0	5.8	2.5
	V	45.7	45.7	7.6	13.5	16.0	66.3	80.5	5.8	2.5
	D	45.7	45.7	13.7	7.6	16.0	66.3	80.5	5.8	2.5
SE060-SE072	H	48.3	44.5	7.6	7.6	3.0	117.1	49.0	5.8	2.5
	V	45.7	45.7	7.6	13.5	16.0	66.3	90.7	5.8	2.5
	D	45.7	45.7	13.7	7.6	16.0	66.3	90.7	5.8	2.5

Corner Weights (kg)

Model	Left - Front	Right - Front	Left - Back	Right/Back
SE006-SE012	25.4	15.4	16.8	15.0
SE018	35.4	29.8	30.0	21.5
SE024	30.8	25.4	19.1	19.1
SE036	34.5	28.6	21.3	21.3
SE048	44.5	36.7	27.2	27.2
SE060-SE072	46.7	38.6	28.6	28.6

Hanger Dimensions (cm)

Model	Cabinet Config	Unit Hanger Detail		
		U	V	W
SE006-SE012	H	109.5	62.2	51.6
SE018	H	157.7	62.2	51.6
SE024	H	122.9	62.5	51.6
SE036	H	135.4	62.5	59.2
SE048	H	172.7	70.1	59.2
SE060-SE072	H	172.7	70.1	59.2

ClimateMaster works continually to improve its products. As a result, the design and specifications of each product at the time of order may be changed without notice and may not be as described herein. Please contact ClimateMaster's Customer Service Department at 1-800-299-9747 for specific information on the current design and specifications. Statements and other information contained herein are not express warranties and do not form the basis of any bargain between the parties, but are merely ClimateMaster's opinion or commendation of its products. The latest version of this document is available at www.climatemaster.com. Engineered and assembled in the USA. © ClimateMaster, Inc. All Rights Reserved 2024

MINIMUM INSTALLATION AREA

Minimum area where a blower-equipped unit must be installed, and mechanical/natural ventilation is not required

Model	Charge (oz)	Configuration	Minimum Installation Area ft ² (m ²) [A _{min}]			
			Floor	Window	Wall	Ceiling
SE060	102	Vertical	351 (32.61)	195 (18.12)	112 (10.41)	92 (8.55)
		Horizontal	351 (32.61)	209 (19.42)	116 (10.78)	95 (8.83)
SE072	109	Vertical	375 (34.84)	209 (19.42)	120 (11.15)	99 (9.20)
		Horizontal	375 (34.84)	223 (20.72)	124 (11.52)	102 (9.48)

A _{min} =	Minimum area where unit is installed where unit has incorporated airflow
h _{inst} (floor) =	0.0 ft (0.0 m)
h _{inst} (window) =	3.3 ft (1.0 m)
h _{inst} (wall) =	5.9 ft (1.8 m)
h _{inst} (ceiling) =	7.2 ft (2.2 m)

Minimum area and CFM requirements for the conditioned space

Model	Charge (oz)	Minimum CFM [Q _{min}]	
		TA _{min} ft ² (m ²)	Q _{min} (ft ³ /min)
SE060	102	5.2 (0.48)	173 (293.07)
SE072	109	5.6 (0.52)	184 (313.19)

TA _{min} =	Minimum conditioned area for venting leaked refrigerant
Q _{min} =	Minimum ventilation flow rate for conditioned space if space is less than TA _{min}

Minimum area of opening for natural ventilation

Model	Charge (oz)	Anv _{min} in ² (m ²)
SE060	102	135.65 (12.60)
SE072	109	140.23 (13.03)

Anv _{min} =	Minimum natural ventilation area opening
----------------------	--

When the openings for connected rooms or natural ventilation are required, the following conditions shall be applied:

- The area of any openings above 11.8 inches (300 mm) from the floor shall not be considered in determining compliance with Anv_{min}.
- At least 50% of the required opening area Anv_{min} shall be below 7.8 inches (200 mm) from the floor.
- The bottom of the lowest openings shall not be higher than the point of release when the unit is installed and not more than 3.9 inches (100 mm) from the floor.
- Openings are permanent openings which cannot be closed.
 - For openings extending to the floor, the height shall not be less than 0.78 inch (20 mm) above the surface of the floor covering.
- A second higher opening shall be provided. The total size of the second opening shall not be less than 50% of minimum opening area for Anv_{min} and shall be at least 3.3 ft (1.5 m) above the floor.

GENERAL

Furnish and install ClimateMaster Tranquility® SE Water-Source Heat Pumps, as indicated on the plans. Equipment shall be completely assembled, piped, and internally wired. Capacities and characteristics as listed in the schedule and the specifications that follow.

Units shall be supplied completely factory built capable of operating over an entering water temperature range from 20° to 120° F (-6.7° to 48.9° C) as standard. Equivalent units from other manufacturers may be proposed provided approval to bid is given 10 days prior to bid closing. All equipment listed in this section must be rated and certified in accordance with Air-Conditioning, Heating and Refrigeration Institute/International Standards Organization (AHRI/ISO 13256-1). All equipment must be tested, investigated, and determined to comply with the requirements of the standards for Heating and Cooling Equipment UL 60335-2-40 4th Edition, UL 60335-1 6th Edition for the United States and Can/CSA C22.2 No. 60335-2-40:22, CAN/CSA C22.2 No 60335-1:16 for Canada, by Intertek Testing Laboratories (ETL). The units shall have AHRI/ISO and ETL-US-C labels.

All units shall pass a factory acceptance test. The quality control system shall automatically perform the factory acceptance test via computer. A detailed report card from the factory acceptance test shall be shipped with each unit.

Note: If a unit fails the factory acceptance test it shall not be allowed to ship. Unit serial number will be recorded by factory acceptance test and furnished on report card for ease of unit warranty status.

BASIC CONSTRUCTION

Horizontal units shall have one of the following air flow arrangements: Left Inlet/Straight (Right) Discharge; Right Inlet/Straight (Left) Discharge; Left Inlet/Back Discharge; or Right Inlet/Back Discharge as shown on the plans. Units must have the ability to be field convertible from straight to back or back to straight discharge with no additional parts or unit structure modification. Horizontal units will have factory installed hanger brackets with EPDM isolation grommets packaged separately.

Vertical units shall have one of the following air flow arrangements: Left Return/Top Discharge, Right Return/Top Discharge, Left Return/Bottom Discharge, Right Return/Bottom Discharge as shown on the plans.

If units with these arrangements are not used, the contractor is responsible for any extra costs incurred by other trades. All units (horizontal and vertical) must have multiple access panels for serviceability of compressor compartment. **Units having only one access panel to compressor/heat exchangers/expansion device/refrigerant piping shall not be acceptable.**

Compressor section interior surfaces shall be lined with ½-inch (12.7 mm) thick, 1½ lb/ft³ (24 kg/m³) acoustic type glass fiber insulation. Air-handling section interior surfaces shall be lined with ½-inch (12.7 mm) thick, 1½ lb/ft³ (24 kg/m³) **foil-faced**, glass-fiber insulation for ease of cleaning. Insulation placement shall be designed in a manner that will eliminate any exposed edges to prevent the introduction of glass fibers into the air stream. **Units without foil-faced insulation in the air handling section will not be accepted.**

The heat pump cabinets shall be fabricated from heavy gauge galvanized steel.

Standard insulation must meet NFPA Fire Hazard Classification requirements 25/50 per ASTM E84, UL 723, CAN/ULC S102-M88 and NFPA 90A requirements; air erosion and mold growth limits of UL-181; stringent fungal resistance test per ASTM-C1071 and ASTM G21; and shall meet zero level bacteria growth per ASTM G22. **Unit insulation must meet these stringent requirements or unit(s) will not be accepted.**

All horizontal units to have factory-installed 1-inch (25.4 mm) discharge air-duct collars, 1-inch (25.4 mm) filter rails with 1-inch (25.4 mm) filters factory installed, and factory-installed, unit-mounting brackets. Vertical units to have field-installed discharge air-duct collar, shipped loose and 1-inch (25.4 mm) filter rails with 1-inch (25.4 mm) filters factory installed. **If units with these factory-installed provisions are not used, the contractor is responsible for any extra costs to field install these provisions, and/or the extra costs for his subcontractor to install these provisions.**

All units must have an insulated panel separating the fan compartment from the compressor compartment. **Units with the compressor in the air stream are not acceptable.** Units shall have a factory-installed 1-inch-wide (25.4 mm) filter bracket for filter removal from either side. Units shall have a 1-inch-thick (25.4 mm), throwaway-type, glass-fiber filter. The contractor shall purchase one spare set of filters and replace factory shipped filters on completion of startup. Filters shall be standard sizes. If units utilize non-standard filter sizes then the contractor shall provide 12 spare filters for each unit.

Cabinets shall have separate holes and knockouts for entrance of line-voltage- and low-voltage-control wiring. All factory-installed wiring passing through factory knockouts and openings shall be protected from sheet metal edges at openings by plastic ferrules. Supply and return water connections shall be copper FPT fittings and shall be securely mounted flush to the cabinet corner post allowing for connection to a flexible hose without the use of a back-up wrench. **Water connections that protrude through the cabinet or require the use of a backup wrench shall not be allowed.** All water connections and electrical knockouts must be in the compressor compartment corner post as to not interfere with the serviceability of unit. The contractor shall be responsible for any extra costs involved in the installation of units that do not have this feature. Contractor must ensure that units can be easily removed for servicing and coordinate locations of electrical conduit and lights with the electrical contractor.

Option: The unit will be supplied with optional field- or factory-installed 2-inch air-filter rails (typically used for free-return installation) or 1-inch or 2-inch air-filter frames with filter-access door and return air-duct flanges (typically used for ducted return installation). A corresponding 1-inch or 2-inch throwaway type glass-fiber filter will ship with the factory-installed filter rail or frame.

Option: The contractor shall install 1-inch or 2-inch MERV-rated, pleated-media, disposable air filters on all units.

Option: UltraQuiet package shall consist of high-technology, sound-attenuating material that is strategically applied to the compressor and air handling compartment casings and fan scroll in addition to the standard ClimaQuiet system design, to further dampen and attenuate sound transmissions.

Option: The unit will be supplied with internal factory-mounted modulating water valve with delta T control. The factory built-in valve shall modulate water flow through unit based on a field-adjustable water temperature difference between the entering and leaving water. For two-stage units, the modulating valve will automatically reduce the water flow through the unit during part-load operation to maintain the configured temperature difference. The valve shall automatically adjust for operating mode, stage of capacity, source water temperature and variations in external head pressure. The valve will also act as a shut-off valve to prevent water flow through the unit when the unit is not activated and will have a minimum position capability. Externally-mounted, modulating water valves will not be accepted.

Option: The unit will be supplied with internal factory-mounted, variable-speed, water-circulating pump with internal check valve. The variable-speed pump shall modulate water flow through the unit based on a field-adjustable temperature difference between the entering and leaving water. For two-stage units, the modulating valve will automatically reduce the water flow through the unit during part-load operation to maintain the configured temperature difference. The variable-speed pump shall automatically adjust for operating mode, stage of capacity, source water temperature, and variations in external head pressure. Externally mounted circulating pumps will not be accepted.

Option: The unit will be supplied with internal mounted secondary pump for primary/secondary applications, including one-pipe systems. Externally mounted secondary pump will not be accepted.

Option: The unit shall be supplied with extended-range insulation option, which adds closed-cell insulation to internal water lines, and provides insulation on suction-side refrigeration tubing including refrigerant-to-water heat exchanger.

BLOWER AND MOTOR ASSEMBLY

Blowers shall have inlet rings to allow removal of wheel and motor from one side without removing housing. Units shall have a direct-drive centrifugal fan. The fan motor shall be an EC variable speed ball-bearing-type motor. The EC blower motor shall provide soft-starting functionality, maintain constant CFM over its static operating range, and provide airflow adjustment in 25 CFM increments via its control board. The fan motor shall be isolated from the housing by rubber grommets. The motor shall be permanently lubricated and have thermal overload protection. A special dehumidification mode shall be provided to allow lower airflows in cooling for better dehumidification. The dehumidification mode may be constant or automatic (humidistat controlled). Airflow/Static pressure rating of the unit shall be based on a wet coil and a clean filter in place.

Ratings based on a dry coil, and/or no air filter, shall NOT be acceptable.

REFRIGERANT CIRCUIT

Unit sizes 006-072 shall contain an R-454B sealed refrigerant circuit including high-efficiency, single-stage (006-018) and two-stage scroll compressors (024-072) designed for heat pump operation; a thermostatic expansion valve for refrigerant metering; enhanced, corrugated-aluminum lanced fin, rifled-copper-tube or all-aluminum-microchannel, refrigerant-to-air heat exchanger; a reversing valve; a coaxial (tube-in-tube) refrigerant-to-water heat exchanger; and safety controls including a high-pressure switch, a low-pressure switch (loss of charge), a water-coil low-temperature sensor, and an air-coil low-temperature sensor.

Access fittings shall be factory-installed on high- and low-pressure refrigerant lines to facilitate field service. Activation of any safety device shall prevent compressor operation via a microprocessor lockout circuit. The lockout circuit shall be reset at the thermostat or at the contractor supplied disconnect switch. **Units that cannot be reset at the thermostat shall not be acceptable.**

Hermetic compressors shall be internally sprung. The compressor shall have a dual level vibration isolation system. The compressor will be mounted on specially engineered sound-tested EPDM vibration isolation grommets to a large heavy gauge compressor mounting plate, which is then isolated from the cabinet base with EPDM grommets for maximized vibration attenuation. All units shall include a discharge muffler to further enhance sound attenuation. Compressors shall have thermal overload protection. Compressors shall be located in an insulated compartment away from air stream to minimize sound transmission.

Refrigerant-to-air heat exchangers shall utilize enhanced, corrugated-aluminum lanced fins, and rifled-copper-tube or all-aluminum-microchannel construction rated to withstand 625 PSIG (4,309 kPa) refrigerant working pressure. Refrigerant-to-water heat exchangers shall be of copper inner-water-tube and steel refrigerant-outer-tube design, rated to withstand 625 PSIG (4,309 kPa) working refrigerant pressure and 300 PSIG (2,068 kPa) working water pressure. The refrigerant-to-water heat exchanger shall be "electro-coated" with a low-cure, cathodic epoxy material a minimum of 0.4 mils thick (0.4 – 1.5 mils range) on all surfaces. The black-colored coating shall provide a minimum of 1,000 hours salt-spray protection per ASTM B117-97 on all external steel and copper tubing. The material shall be formulated without the inclusion of any heavy metals and shall exhibit a pencil hardness of 2H (ASTM D3363-92A), crosshatch adhesion of 4B-5B (ASTM D3359-95), and impact resistance of 160 in-lbs (184 kg-cm) direct (ASTM D2794-93).

Refrigerant metering shall be accomplished by thermostatic expansion valve only. Expansion valves shall be dual-port balanced types with external equalizer for optimum refrigerant metering.

ClimateMaster works continually to improve its products. As a result, the design and specifications of each product at the time of order may be changed without notice and may not be as described herein. Please contact ClimateMaster's Customer Service Department at 1-800-299-9747 for specific information on the current design and specifications. Statements and other information contained herein are not express warranties and do not form the basis of any bargain between the parties, but are merely ClimateMaster's opinion or commendation of its products. The latest version of this document is available at www.climatemaster.com. Engineered and assembled in the USA. © ClimateMaster, Inc. All Rights Reserved 2024

Units shall be designed and tested for operating ranges of entering water temperatures from 20° to 120° F (-6.7° to 48.9° C). Reversing valve shall be four-way, solenoid-activated refrigerant valve, which shall default to heating mode should the solenoid fail to function. If the reversing valve solenoid defaults to cooling mode, an additional low-temperature thermostat must be provided to prevent over-cooling an already cold room.

Units charged with 62 ounces (1.76 kilograms) or greater of R-454B shall be supplied with a Refrigerant Detection System (RDS) with sensors to be strategically placed within the cabinet. In the event of a refrigerant leak, the RDS disables compressor operation, and the unit blower runs to disperse any concentration of leaked refrigerant in compliance with UL 60335-2-40 safety standards for flammable refrigerants. **Units charged with 62 ounces (1.76 kilograms) or greater of R-454B that do not have an RDS shall not be acceptable.**

Option: The unit will be supplied with a cupro-nickel coaxial water-to-refrigerant heat exchanger.

Option: The unit shall be supplied with a hot-water generator (desuperheater).

Option: The Refrigerant Detection System (RDS) package shall consist of the RDS module and sensors to be strategically placed within the cabinet. In the event of a refrigerant leak, the RDS disables compressor operation, and the unit blower runs to disperse any concentration of leaked refrigerant in compliance with UL 60335-2-40 safety standards for flammable refrigerants (Optional for sizes 006-048).

DRAIN PAN

The drain pan shall be constructed of 304 Stainless Steel to inhibit corrosion. This corrosion protection system shall meet the stringent 1,000-hour salt-spray test per ASTM B117. If plastic-type material is used, it must be HDPE (High Density Polyethylene) to avoid thermal-cycling-shock stress failure over the lifetime of the unit. The drain pan shall be fully insulated. The drain outlet shall be located at pan to allow unobstructed drainage of condensate. Drain outlet for horizontal units shall be connected from pan directly to MPT fitting. **No hidden internal tubing extensions from pan outlet extending to unit casing (that can create drainage problems) will be accepted.** The unit as standard will be supplied with solid-state electronic condensate overflow protection. **Mechanical float switches will NOT be accepted.**

Vertical units shall be furnished with a PVC FPT condensate-drain connection and an internal, factory-installed, condensate trap. If units without an internal trap are used, the contractor is responsible for any extra costs to field install these provisions, and/or the extra costs for his sub-contractor to install these provisions.

ELECTRICAL

A control box shall be located within the unit compressor compartment and shall contain a 75VA transformer, 24V-activated, two- or three-pole-compressor contactor, terminal block for thermostat wiring and solid-state controller for complete unit operation. Reversing valve and blower motor wiring shall be routed through this electronic controller. Units shall be name-plated for use with time-delay fuses or HACR circuit breakers. Unit controls shall be 24V and provide heating or cooling as required by the remote thermostat/sensor.

Option: Disconnect Switch, Non-Fused, classified as motor disconnect.

ENHANCED SOLID STATE CONTROL SYSTEM (DXM2.5)

Units shall have a solid-state control system. Units utilizing electro-mechanical control shall not be acceptable. The control-system microprocessor board shall be specifically designed to protect against building electrical-system noise contamination, EMI, and RFI interference. This control system is a communicating controller with the following features.

- a. Anti-short cycle time delay on compressor operation.
- b. Random start on power up mode.
- c. Low-voltage protection.
- d. High-voltage protection.
- e. Unit shutdown on high or low refrigerant pressures.
- f. Unit shutdown on low water temperature.
- g. Condensate-overflow electronic protection.
- h. Option to reset unit at thermostat or disconnect.
- i. Automatic intelligent reset. Unit shall automatically reset the unit 5 minutes after trip if the fault has cleared. If a fault occurs 3 times sequentially without thermostat meeting temperature, then lockout requiring manual reset will occur.
- j. Ability to defeat time delays for servicing.
- k. Light-emitting diode (LED) on circuit board to indicate high-pressure, low-pressure, low-voltage, high-voltage, low-water/air-temperature cut-out, condensate-overflow, and control-voltage status.
- l. The low-pressure switch shall not be monitored for the first 120 seconds after a compressor start command to prevent nuisance safety trips.
- m. 24V output to cycle a motorized water valve or other device with compressor contactor.
- n. Unit Performance Sentinel (UPS). The UPS warns when the heat pump is running inefficiently.
- o. Water coil low-temperature sensing (selectable for water or antifreeze).
- p. Air coil low-temperature sensing.
- q. Removable thermostat connector.
- r. Night-setback control.
- s. Random start on return from night setback.
- t. Minimized reversing-valve operation (Unit control logic shall only switch the reversing valve when cooling is demanded for the first time. The reversing valve shall be held in this position until the first call for heating, ensuring quiet operation and increased valve life).
- u. Override temperature control with 2-hour timer for room occupant to override setback temperature at the thermostat.
- v. Dry-contact night-setback output for digital night-setback thermostats.
- w. Ability to work with heat pump (Y, O) or heat/cool (Y, W) type thermostats.
- x. Ability to work with heat-pump thermostats using O or B reversing-valve control.
- y. Emergency-shutdown contacts.
- z. Entering- and leaving-water temperature sensing.
 - aa. Leaving-air temperature sensing.
 - ab. Compressor-discharge temperature sensing.
 - ac. Boilerless system heat control at low loop water temperature.
 - ad. Ability to allow up to three units to be controlled by one thermostat.
 - ae. Relay to operate an external damper.
 - af. Relay to start system pump.
 - ag. 75VA control transformer. Control transformer shall have load side short circuit and overload protection via a built-in circuit breaker.

NOTE: Units not providing the eight safety protections of anti-short-cycle, low-voltage, high-voltage, high-refrigerant-pressure, low-pressure (loss of charge), air-coil low-temperature cut-out, water-coil low-temperature cut-out, and condensate-overflow protection will not be accepted.

NOTE: To achieve full benefit of the two-stage compressor and EC fan, a 2 Heat/2 Cool thermostat (or a 3 Heat/2 Cool thermostat when electric backup heat is required) should be employed.

When DXM2.5 is connected to either Wireless Service Tool or AWC Thermostat, the installer/service technician can; check and set CFM; check DIP switch S1, S2, and S3 settings; run operation modes manually; check all physical inputs from thermostat and refrigerant pressure switches status, (Y1, Y2, W, O, G, H, ESD, NSB, OR, HP switch, and LOC switch); current or at time of fault the following temperatures - water coil (LT1), air coil (LT2), compressor discharge, leaving air, leaving water, entering water, and control voltage; record last five faults, list possible reasons, and clear faults. When the AWC Thermostat is used, this same functionality can be viewed and adjusted remotely with the online portal or mobile app. **Systems not providing remote access, diagnosis, and adjustment functionality will not be accepted.**

DIGITAL NIGHT-SETBACK WITH PUMP RESTART (DXM2.5 W/ ATP32U03C/04C, AWC99U01)

The unit will be provided with a digital night-setback feature using an accessory relay on the DXM2.5 and an external, field-provided time clock. The external time clock will initiate and terminate the night-setback period. The thermostat will have a night-setback-override feature with a programmable override time period. An additional accessory relay on the unit DXM2.5 will energize the building-loop pump control for the duration of the override period.

NOTE: This feature requires additional low voltage wiring. Consult Application Drawings for details.

REMOTE SERVICE SENTINEL

Solid-state control system shall communicate with thermostat to display (at the thermostat) the unit status, fault status, and specific fault condition, as well as retrieve previously stored fault that caused unit shutdown. The Remote Service Sentinel allows building maintenance personnel or service personnel to diagnose units from the wall thermostat. The control board shall provide a signal to the thermostat fault light, indicating a lockout. Upon cycling the G (fan) input three times within a 60-second time period, the fault light shall display the specific code as indicated by a sequence of flashes. A detailed flashing code shall be provided at the thermostat LED to display unit status and specific fault status such as over/under-voltage fault, high-pressure fault, low-pressure fault, low-water-temperature fault, condensate-overflow fault, etc. **Units that do not provide this remote service sentinel shall not be acceptable.**

Option: MPC (Multiple Protocol Control) Interface System

Units shall have all the features listed above and the control board will be supplied with a Multiple Protocol interface board. Available protocols are BACnet MS/TP, Modbus, or Johnson Controls N2. The choice of protocol shall be field-selectable/changeable via the use of a simple selector switch. **Protocol selection shall not require any additional programming or special external hardware or software tools.** This will permit all units to be daisy chain connected by a 2-wire, twisted-pair, shielded cable. The following points must be available at a central or remote computer location:

- a. space temperature
- b. leaving-water temperature

- c. discharge-air temperature
- d. command-of-space temperature setpoint
- e. cooling status
- f. heating status
- g. low-temperature sensor alarm
- h. low-pressure sensor alarm
- i. high-pressure switch alarm
- j. condensate-overflow alarm
- k. high-/low-voltage alarm
- l. fan "ON/AUTO" position of space thermostat as specified above
- m. unoccupied/occupied command
- n. cooling command
- o. heating command
- p. fan "ON/AUTO" command
- q. fault-reset command
- r. itemized fault code revealing reason for specific shutdown fault (any one of seven)
- s. refrigerant-leak-detection communication path

WARRANTY

ClimateMaster shall warranty equipment for a period of 12 months from start up or 18 months from shipping (whichever occurs first).

Option: Extended 4-year compressor warranty covers compressor for a total of 5 years.

Option: Extended 4-year refrigeration circuit warranty covers coils, reversing valve, expansion valve and compressor for a total of 5 years.

Option: Extended 4-year control board warranty covers the DXM2.5 for a total of 5 years.

FIELD-INSTALLED OPTIONS

Hose Kits

All units shall be connected with hoses. The hoses shall be 2-feet-long (61-cm), braided, stainless-steel, fire-rated hoses complete with adapters. Only fire-rated hoses will be accepted.

Valves

The following valves are available and will be shipped loose:

- a. Ball valve; bronze material, standard port full-flow design, FPT connections.
- b. Ball valve with memory stop and PT port.
- c. "Y" strainer with blowdown valve; bronze material, FPT connections.
- d. Motorized water valve; slow acting, 24V, FPT connections.

Hose Kit Assemblies

The following assemblies ship with the valves already assembled to the hose described:

- a. Supply and return hoses having ball valve with PT port.
- b. Supply hose having ball valve with PT port; return hose having automatic flow-regulator valve with PT ports, and ball valve.
- c. Supply hose having "Y" strainer with blowdown valve, and ball valve with PT port; return hose having automatic flow regulator with PT ports, and ball valve.
- d. Supply hose having "Y" strainer with blowdown valve, and ball valve with PT port; return hose having ball valve with PT port.

THERMOSTATS

The thermostat shall be a ClimateMaster mechanical or electronic type thermostat as selected below with the described features:

a. iGate 2 Communicating (AWC) Thermostat (AWC99U01)

An electronic, communicating, web-enabled, touchscreen thermostat shall be provided. The thermostat shall offer three stages of heating and two stages of cooling with precise temperature control and have a four-wire connection to the unit. The thermostat shall be capable of manual or automatic change-over operation and shall operate in standard or programmable mode. An integrated humidity control feature shall be included to control a humidifier and/or a dehumidifier. The thermostat shall include a utility demand-reduction feature to be initiated by an independent time program or an external input. The thermostat shall provide access to via the web portal or mobile application to include temperature adjustment, schedule adjustment including occupied/unoccupied, entering-water temperature, leaving-water temperature, water-coil temperature, air-coil temperature, leaving-air temperature, and compressor-discharge temperature. A graphical system layout to be provided with real-time operating mode information of the temperature sensors for easy diagnostics. The thermostat shall display system faults with probable cause and troubleshooting guidance. The system shall provide—in clear language—last five faults, time of faults, operating temps at time of fault, and possible reasons for the fault. The thermostat shall provide access for immediate manual control of all outputs via the web portal/mobile application for rapid troubleshooting.

b. CM500 – Color Touchscreen Display, Multi-stage, Automatic or Manual Changeover, 7-day Programmable with Wi-Fi and Humidity Control (AVB32V03C/R)

The thermostat shall have color resistive touchscreen display with space temperature, relative humidity, setpoints, mode, status indication and local weather (if connected to Wi-Fi). Residential version shall be 7-day programmable with up to four setpoints per day. Commercial version shall be 7-day programmable with four occupied/unoccupied periods per day with up to 4-hour override. Multi-stage (3H/2C), automatic or manual changeover with HEAT-OFF-COOL-AUTO-EM HEAT system settings and fan ON-AUTO settings, Wi-Fi, pre-occupancy purge fan option, customizable screen saver and background displays, indicator on display indicates a heating or cooling demand, set-point lock, title 24 compliant, openADR2.0b certified with Skyport web portal. Compatible with condensate-overflow warning systems – lockout compressor with message on the display. Capable of being monitored by 3rd-party software. Compatible with AST014 Wi-Fi remote sensor. Configurator mobile app or web portal for easy setup. Separate dehumidification and humidification setpoints shall be configurable for discreet outputs to a dehumidification option and/or an external humidifier. The temperature indication shall be selectable for °F or °C. Time display shall be selectable for 12- or 24-hour clock. The thermostat shall provide permanent memory of setpoints without batteries. The thermostat shall provide heating-setpoint-range limit, cooling-setpoint-range limit, temperature display offset, dead-band range setting, and inter-stage differential settings. The thermostat shall provide progressive recovery to anticipate time required to bring space temperature to the next programmed event. The thermostat shall provide access to a web portal and mobile app for installer setup for configuring options. The thermostat shall have menu-driven selections for ease of use and programming.

c. CM300 – Multi-stage, Automatic or Manual Changeover, 7-day Programmable with Wi-Fi and Humidity Control (AVB32V02C/R)

Residential version shall be 7-day programmable with up to four setpoints per day. Commercial version shall be 7-day programmable with four occupied/unoccupied periods per day with up to 4-hour override. Multi-stage (3H/2C), automatic or manual changeover with HEAT-OFF-COOL-AUTO-EM HEAT system settings and fan ON-AUTO settings, Wi-Fi, pre-occupancy-purge fan option, night time control of display backlight, bi-color LED indicates a heating or cooling demand, keypad lock, title 24 compliant, openADR2.0b certified with Skyport web portal. Compatible with condensate-overflow warning systems – lockout compressor with message on

d. CM100 – Multi-stage Automatic or Manual Changeover digital thermostat (ATA32V01)

Multi-stage (3H/2C), automatic or manual changeover with HEAT-OFF-COOL-AUTO-EM HEAT system settings and fan ON-AUTO settings. The thermostat shall have a green backlit LED display with temperature, setpoints, mode, and status indication via a green (cooling) or red(heating) LED. The temperature indication shall be selectable for °F or °C. Time display shall be selectable for 12- or 24- hour clock. The thermostat shall provide permanent memory of setpoints without batteries. Thermostat shall provide heating-setpoint-range limit, cooling-setpoint-range limit, temperature display offset, keypad lockout, dead-band range setting, and inter-stage differential settings. The thermostat shall provide progressive recovery to anticipate time required to bring space temperature to the next programmed event. The thermostat shall provide an installer setup for configuring. The thermostat navigation shall be accomplished via four buttons (Mode/fan/down/up) with menu-driven selections for ease of use and programming.

e. Multi-stage Automatic or Manual Changeover Programmable 7-Day (ATP32U03C)

Thermostat shall be 7-day programmable (with up to 4 setpoints per day), multi-stage (3H/2C), automatic or manual changeover with HEAT-OFF-COOL-AUTO-EM HEAT system settings and fan ON-AUTO settings. Thermostat shall have a blue-backlit, dot-matrix LCD display with temperature, setpoints, mode, and status indication. The temperature indication shall be selectable for °F or °C. Time display shall be selectable for 12- or 24-hour clock. Fault identification shall be provided to simplify troubleshooting by providing specific unit fault at the thermostat with red-backlit LCD during unit lockout. The thermostat shall provide permanent memory of setpoints without batteries. Thermostat shall provide heating-setpoint-range limit, cooling-setpoint-range limit, temperature-display offset, keypad lockout, dead-band range setting, and inter-stage differential settings. Thermostat shall provide progressive recovery to anticipate time required to bring space temperature to the next programmed event. Thermostat shall provide an installer setup for configuring options and for setup of servicing-contractor name and contact information. Thermostat shall allow the use of an accessory remote and/or outdoor temperature sensor (AST008). Thermostat navigation shall be accomplished via five buttons (up/down/right/left/select) with menu-driven selections for ease of use and programming.

f. Multi-stage Digital Automatic Changeover (ATA22U01)

Thermostat shall be multi-stage (2H/2C), manual or automatic changeover with HEAT-OFF-COOL-AUTO-EM HEAT system settings and fan ON-AUTO settings. Thermostat shall have an LCD display with temperature, setpoint(s), mode, and status indication. The temperature indication shall be selectable for °F or °C. The thermostat shall provide permanent memory of setpoint(s) without batteries. A fault LED shall be provided to indicate specific fault condition(s). Thermostat shall provide temperature-display offset for custom applications. Thermostat shall allow unit to provide better dehumidification by automatically using lower fan speed on stage-one cooling (higher latent cooling) as main cooling mode, and automatically shifting to high-speed fan on stage-two cooling.

g. Multi-stage Automatic or Manual Changeover Programmable 7-Day with Humidity Control (ATP32U04C)

Thermostat shall be 7-day programmable (with up to 4 setpoints per day), multi-stage (3H/2C), automatic or manual changeover with HEAT-OFF-COOL-AUTO-EM HEAT system settings and fan ON-AUTO settings. Separate dehumidification and humidification setpoints shall be configurable for discreet outputs to a dehumidification option and/or an external humidifier. Installer configuration mode shall allow thermostat to operate with EC fan dehumidification mode via settings changes. Thermostat shall have a blue-backlit, dot-matrix LCD display with temperature, relative humidity, setpoints, mode, and status indication. The temperature indication shall be selectable for °F or °C. Time display shall be selectable for 12- or 24-hour clock. Fault identification shall be provided to simplify troubleshooting by providing specific unit fault at the thermostat with red-backlit LCD during unit lockout. The thermostat shall provide permanent memory of setpoints without batteries. Thermostat shall provide heating-setpoint-range limit, cooling-setpoint-range limit, temperature-display offset, keypad lockout, dead-band range setting, and inter-stage differential settings. Thermostat shall provide progressive recovery to anticipate time

required to bring space temperature to the next programmed event. Thermostat shall provide an installer setup for configuring options and for setup of servicing-contractor name and contact information. Thermostat shall allow the use of an accessory remote and/or outdoor temperature sensor (AST008). Thermostat navigation shall be accomplished via five buttons (up/down/right/left/select) with menu-driven selections for ease of use and programming.

DDC SENSORS

ClimateMaster wall mounted DDC sensor to monitor room temperature and interfaces with optional interface system described above. Several types as described below:

- Sensor only with no display (MPC).
- Sensor with setpoint adjustment and override (MPC only).
- Sensor with setpoint adjustment and override, LCD display, status/fault indication (MPC).

WIRELESS SERVICE TOOL

Allows installation and service personnel to access the configuration and service modes of the DXM2.5 without installing the AWC Thermostat:

- Configure the airflow, pump, or modulating valve operation etc.
- Diagnose by viewing fault history and operating conditions at the time of fault and manually operating the unit.

NOTICE

This product specification document is furnished as a means to copy and paste ClimateMaster product information into project specification. It is not intended to be a complete list of product requirements. This document is an excerpt from the product submittal and must not be used without consulting the complete product submittal. For complete product installation and application requirements, please consult the complete product submittal. ClimateMaster is not responsible for misuse of this document or a failure to adequately review specific requirements in the product catalog.

Revision History

Models:
SE
006-072

Date	Section	Description
02/21/25	Introduction	Updated introduction
	Performance Data	Added a note concerning Hot Water Generator Capacity calculation
	Blower Performance: CV EC Standard Unit	Corrected Stage 1 and Stage 2 columns
	Electrical Data	Updated RLA and LRA values for size 072
	Part Load Performance: Correction Tables	Updated correction data for Cooling, Entering Air Heating, and Airflow
	Full Load Performance: Correction Tables	Updated correction data for Cooling, Entering Air Heating, and Airflow
	Dimensional Data	Added shipping dimensions
	All	Added the Wireless Service Tool
12/11/24	All	Reorganized the document's sections
	Full Load Performance: Correction Tables	Updated correction data for Cooling, Entering Air Heating, and Airflow
10/23/24	Electrical Data	Updated electrical data for SE048-072
	Blower Performance: CV EC Standard Unit	Added note concerning maximum allowable altitude of installation
09/27/24	Physical Data	Updated the packaged weight for the SE024
	Engineering Specifications	Updated Unit Maximum Water Working Pressure
	Dimensional Data	Updated measurements for O
	Performance Data	Updated performance data
	Blower Performance	Updated blower performance data
08/08/24	Vertical Downflow Dimensional Data	Added section
	All	Added sizes 006-018
06/11/24	Physical Data	Updated Unit Maximum Water Working Pressure
	Performance Data	Updated all performance data
05/14/24	Minimum Installation Area	Data updated
03/06/24	All	Created



A **NIBE** GROUP MEMBER

7300 SW 44th St | Oklahoma City, OK 73179

Phone: 800.299.9747

www.climatemaster.com

ClimateMaster works continually to improve its products. As a result, the design and specifications of each product at the time of order may be changed without notice and may not be as described herein. Please contact ClimateMaster's Customer Service Department at 1-800-299-9747 for specific information on the current design and specifications. Statements and other information contained herein are not express warranties and do not form the basis of any bargain between the parties, but are merely ClimateMaster's opinion or commendation of its products. The latest version of this document is available at www.climatemaster.com. Engineered and assembled in the USA. © ClimateMaster, Inc. All Rights Reserved 2024