

Tranquility® 16 (TC) Compact Series

Submittal Data

Models TCH/V006 - 060 60Hz - HFC-410A



LC405

Rev.: August 15, 2023



ClimateMaster works continually to improve its products. As a result, the design and specifications of each product at the time of order may be changed without notice and may not be as described herein. Please contact ClimateMaster's Customer Service Department at 1-405-745-6000 for specific information on the current design and specifications. Statements and other information contained herein are not express warranties and do not form the basis of any bargain between the parties, but are merely ClimateMaster's opinion or commendation of its products. The latest version of this document is available at climatemaster.com. © ClimateMaster, Inc. All rights reserved 2009

Table of Contents

TC Series



	Introduction	4
	Features, Options, and Accessories	5
	iGate® 2 Communicating Controls Powered by CXM2	6
	iGate® 2 Communicating Controls Powered by DXM2.5	7
	iGate® 2 Communicating (AWC) Thermostat	8
	myUplink – Web and Mobile Interface	9
	Constant Volume (CV) ECM	10
	Constant Torque (CT) ECM	11
	Selection Procedure	12
	TC Series Nomenclature	14
	Performance Data – ASHRAE/AHRI/ISO 13256-1	15
	Performance Data – Selection Notes	16
	Performance Data – TC H/V 006 (PSC Blower)	17
	Performance Data – TC H/V 006 (ECM Blower)	18
	Performance Data – TC H/V 009 (PSC Blower)	19
	Performance Data – TC H/V 009 (ECM Blower)	20
	Performance Data – TC H/V 012 (PSC Blower)	21
	Performance Data – TC H/V 012 (ECM Blower)	22
	Performance Data – TC H/V 015 (PSC Blower)	23
	Performance Data – TC H/V 015 (ECM Blower)	24
	Performance Data – TC H/V 018 (PSC Blower)	25
	Performance Data – TC H/V 018 (ECM Blower)	26
	Performance Data – TC H/V 024 (PSC Blower)	27
	Performance Data – TC H/V 024 (ECM Blower)	28
	Performance Data – TC H/V 030 (PSC Blower)	29
	Performance Data – TC H/V 030 (ECM Blower)	30
	Performance Data – TC H/V 036 (PSC Blower)	31
	Performance Data – TC H/V 036 (ECM Blower)	32
	Performance Data – TC H/V 041 (PSC Blower)	33
	Performance Data – TC H/V 042 (PSC Blower)	34
	Performance Data – TC H/V 042 (ECM Blower)	35
	Performance Data – TC H/V 048 (PSC Blower)	36
	Performance Data – TC H/V 048 (ECM Blower)	37
	Performance Data – TC H/V 060 (PSC Blower)	38
	Performance Data – TC H/V 060 (ECM Blower)	39
	Performance Correction Tables for Units	40

Document page number is shown next to part number (e.g. LC405 - 3 = page 3). Since not all pages are typically used in the submittals process, the page number in the lower right corner can still be used (page ____ of ____).

ClimateMaster works continually to improve its products. As a result, the design and specifications of each product at the time of order may be changed without notice and may not be as described herein. Please contact ClimateMaster's Customer Service Department at 1-405-745-6000 for specific information on the current design and specifications. Statements and other information contained herein are not express warranties and do not form the basis of any bargain between the parties, but are merely ClimateMaster's opinion or commendation of its products. The latest version of this document is available at climatemaster.com. © ClimateMaster, Inc. All rights reserved 2009

Table of Contents

TC Series



Antifreeze Correction Table	41
Blower Performance Data – TC006	43
Blower Performance Data – TC009	44
Blower Performance Data – TC012	45
Blower Performance Data – TC015	46
Blower Performance Data – TC018	47
Blower Performance Data – TC024	48
Blower Performance Data – TC030	49
Blower Performance Data – TC036	50
Blower Performance Data – TC041	51
Blower Performance Data – TC042	52
Blower Performance Data – TC048	53
Blower Performance Data – TC060	54
Waterside Economizer Data	55
Airside PD	58
Waterside Economizer Correction Tables	59
Physical Data	60
TC: Horizontal – Dimensional Data	61
TCH with Waterside Economizer – Dimensional Data	63
TC: Horizontal Service Access	65
TC: Vertical Upflow – Dimensional Data	66
TC: Front Return Vertical Upflow – Dimensional Data	68
TCV with Waterside Economizer – Dimensional Data	69
TC: Vertical Service Access	71
Corner Weights for TCH Series Units	72
Electrical Data: Standard Unit	73
Electrical Data: High Static Blower	74
Electrical Data: Constant Torque (CT) ECM	75
Electrical Data: Constant Volume (CV) ECM	76
TC Series Wiring Diagram Matrix	77
Engineering Specifications	78
Performance Sheet	88
Revision History	90

THE TRANQUILITY® 16 (TC) COMPACT SERIES

The award winning Tranquility® 16 (TC) Compact Series raises the bar for water-source heat pump efficiencies, features and application flexibility. Not only does the Tranquility TC exceed ASHRAE 90.1 efficiencies, but it also uses EarthPure® HFC-410A zero ozone depletion refrigerant, making it an extremely environmentally-friendly option. Tranquility TC is eligible for LEED® (Leadership in Energy and Environmental Design) points because of the “green” technology design. With one of the smallest cabinets in the industry, the Tranquility TC will easily fit into tight spaces. Designed to be backward compatible with thousands of older water-source heat pumps, the Tranquility 16 (TC) Compact Series heat pump is packed full of the innovation you have come to expect from the experts at ClimateMaster.

Available in sizes from 1/2 ton (1.76 kW) through 5 tons (17.6 kW) with multiple cabinet options (vertical upflow and horizontal) the Tranquility TC offers a wide range of units for most any application. The Tranquility TC has an extended range refrigerant circuit, capable of geothermal ground loop applications (with optional extended range insulation) as well as boiler-tower water loop applications. Standard features include: scroll compressors (rotary for size 018 and below), microprocessor controls, galvanized steel cabinet, polymer drain pan and sound absorbing air handler insulation are just some of the features of the Tranquility TC.

ClimateMaster’s exclusive double isolation compressor mounting system makes the Tranquility TC one of the quietest units on the market. Compressors are mounted on specially engineered sound-tested EPDM grommets to a heavy gauge mounting plate, which is further isolated from the cabinet base with rubber grommets for maximized vibration/sound attenuation. The easy access control box and large access panels make installing and maintaining the unit easier than other water-source heat pumps currently in production, proving that a small unit can be easy to service.

Options such as tin-plated air coil, DDC controls, and high efficiency pleated MERV rated air filters allow customized design solutions. Optional high static fan motor expands the operating range and helps overcome some of the challenges associated with ductwork for retrofit installations. Two tiers of ECM fan motor options allow for premium efficiency at a budget price with a Constant Torque (CT) ECM or maximized airflow control with an intelligent Constant Volume (CV) ECM. Cupro-nickel water-coils and ClimateMaster’s industry leading sound attenuation UltraQuiet package are options that make a great unit even better.

Waterside Economizers (WSE) take advantage of cool loop water temperatures and can provide cooling without the use of power consuming compressor operation. In shoulder seasons, lower building loop temperatures can be leveraged when there is cooling demand by adding a factory installed hydronic coil. The WSE option meets IECC section C403.3.1 and is a requirement in many states.

iGate® 2 technology provides technicians an interface into the operation of the system in real time without the need for hard tooling. On board advanced controls communicate the key operating system temperatures enabling technicians to start-up, commission, and service the equipment remotely by smart phone or website via the cloud. Communication can also be done at the unit via a communicating thermostat or handheld service tool. Not only does iGate 2 monitor current performance, it also allows the functionality to make system adjustments and captures operating conditions at time of fault. All this information is displayed in an easy to read format maximizing the usability of the experience.

The Tranquility 16 (TC) Compact Series Water-Source Heat Pumps are designed to meet the challenges of today’s HVAC demands with one of the most innovative products available on the market.

Features, Options and Accessories

FEATURES

- Sizes 006 (1/2 ton, 1.76 kW) through 060 (5 tons, 17.6 kW)
- Environmentally-friendly EarthPure® (HFC-410A) zero ozone depletion refrigerant
- Exceeds ASHRAE 90.1 efficiencies
- Coaxial heat exchanger
- Galvanized steel construction
- Sound absorbing glass fiber insulation
- Unique double isolation compressor mounting for quiet operation
- Insulated divider and separate compressor/air handler compartments
- TXV metering device
- Microprocessor controls with on board fuse and emergency shutdown
- Field convertible discharge air arrangement for horizontal units
- PSC three-speed fan motor (2 speed for 575 volt)
- Unit Performance Sentinel performance monitoring system
- Eight Safeties Standard
- Non-corrosive polymer drain pan
- iGate® 2 Communicating Controls Powered by CXM2
 - Multiple communication pathways,
 - o Cloud-based connectivity via iGate 2 Wi-Fi communicating color touch screen thermostat for remote monitoring, access, and diagnosis. Including the new functionality for contractors/building engineers to monitor and make mass changes on multi-unit systems
 - o Connect directly to the system with use of a handheld service tool
 - Provides real-time unit operating conditions
 - Reduces start-up, commissioning, and service time by removing the need for hard tooling to take temperature measurements
 - Captures operating conditions in the event of a safety shutdown

OPTIONS

- iGate® 2 Communicating Controls Powered by DXM2.5
 - Includes all of the features listed above for CXM2 controls including cloud-based connectivity via iGate 2 WiFi communicating color touch screen thermostat for remote monitoring, access, and diagnosis
 - Provides direct control over intelligent Constant Volume (CV) ECM fan motor
- High Static PSC Fan Motors
- BACnet, Modbus and Johnson N2 compatibility options for DDC controls
- Corrosive resistant cupro-nickel water heat exchanger
- UltraQuiet sound attenuation package
- High efficient ECM fan motors
 - Intelligent Constant Volume (CV) ECM motors for ultimate airflow control
 - Entry level Constant Torque (CT) ECM motors that provide efficiency at a value
- Waterside Economizer (WSE)
- Easy to clean rust prohibitive stainless steel drain pans
- Electrical service disconnect
- Extended range insulation for geothermal applications
- Tin-plated air coils for added protection from formicary corrosion

ACCESSORIES

- Wi-Fi communicating color touch screen thermostat
- Wide variety of thermostat options to meet your application needs
- Various length braided hose kits with optional water valves, PT plugs, blowdown valve, flow limiting, and strainer options
- Externally mounted manual and motorized water valves
- 1" Merv 8 filter
- 2" Merv 8 or 13 filters
- Architecturally pleasing wall sensors for connection to DDC (MPC) controls
- Electric emergency duct heaters

iGate[®] 2 Communicating Controls Powered by CXM2

iGate[®] 2 Communication – Cloud connected, web-enabled information gateway to monitor, control, and diagnose your system

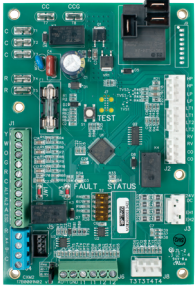

Tranquility[®] 16 (TC) Compact Series is equipped with industry-first, iGate[®] 2 communication information gateway that allows users to interact with their water-source system in easy to read clear language.

Monitor/Configure – Installers can configure from the myUplink PRO website, mobile app, iGate 2 Communicating (AWC) Thermostat, or diagnostic tool, including: Unit family, size, accessory configuration, and demand reduction (optional, to limit unit operation during peak times). Users can look up the current system status: temperature sensor readings and operational status of the blower.

Precise Control – The new CXM2 board enables intelligent, 2-way communication between the CXM2 board and smart components like the communicating thermostat and diagnostic tool. The advanced CXM2 board uses information received from the temperature sensors to precisely control operation to deliver high efficiency, reliability and increased comfort.

Diagnostics – iGate 2 takes diagnosing water source heat pump units to a next level of simplicity, by providing a dashboard of system and fault information, in clear language, on the AWC Communicating Thermostat, handheld service tool and the web portal/mobile app on the internet.

iGate 2 Thermostat Service Warnings notify the homeowner and contractor of a fault and displays fault descriptions by app notifications/email with possible causes. Additionally, the current system status can be viewed graphically on the web portal and mobile app.

In iGate 2 Service Mode, the service personnel can access fault description, possible causes and most importantly, the conditions (temp, flow, i/o conditions, configuration) at the time of the fault. Manual Operation mode allows the service personnel to manually command operation for any of the thermostat outputs, blower speed, to help troubleshoot specific components. This operation can either be conducted at the unit with a communicating thermostat/diagnostic tool or remotely with mobile app/website when the AWC Communicating Thermostat controls are used.

With an iGate 2 communicating system, users and contractors have a web-enabled gateway to system information never before available and exclusive to ClimateMaster products.

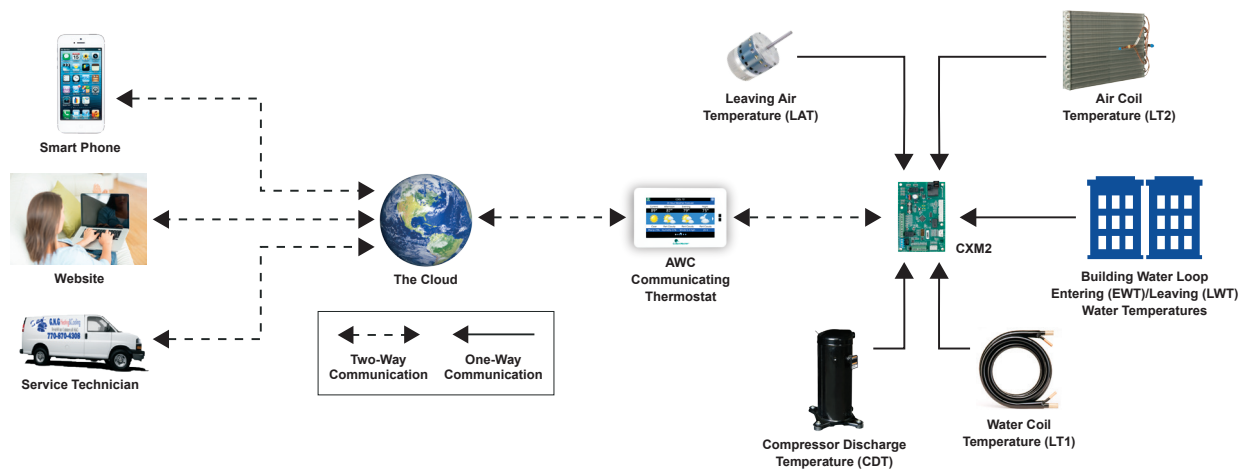

iGate® 2 Communicating Controls Powered by DXM2.5

iGate® 2 Communication – Cloud connected, web-enabled information gateway to monitor, control, and diagnose your system

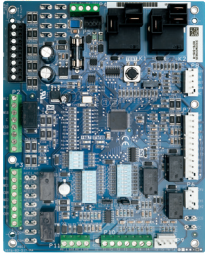

Tranquility® 16 (TC) Compact Series is equipped with industry-first, iGate® 2 communication information gateway that allows users to interact with their water-source system in easy to read clear language AND delivers improved reliability/efficiency by precisely controlling smart components.

Monitor/Configure – Installers can configure from the myUplink PRO website, mobile app, iGate 2 Communicating AWC Thermostat, or diagnostic tool, including: Airflow, unit family, size, accessory configuration, and demand reduction (optional, to limit unit operation during peak times). Users can look up the current system status: temperature sensor readings and operational status of the blower.

Precise Control – The new DXM2.5 board enables intelligent, 2-way communication between the DXM2.5 board and smart components like the communicating thermostat/diagnostic tool and constant volume (CV) EC fan motor. The advanced DXM2.5 board uses information received from the smart components and temperature sensors to precisely control operation of the variable speed CV EC fan motor to deliver higher efficiency, reliability and increased comfort.

Diagnostics – iGate 2 takes diagnosing water source heat pump units to a next level of simplicity, by providing a dashboard of system and fault information, in clear language, on the AWC Communicating Thermostat, handheld service tool and the web portal/mobile app on the internet.

iGate 2 Thermostat Service Warnings notify the homeowner and contractor of a fault and displays fault descriptions by app notifications/email with possible causes. Additionally, the current system status can be viewed graphically on the web portal and mobile app.

In iGate 2 Service Mode, the service personnel can access fault description, possible causes and most importantly, the conditions (temp, flow, i/o conditions, configuration) at the time of the fault. Manual Operation mode allows the service personnel to manually command operation for any of the thermostat outputs, blower speed, to help troubleshoot specific components. This operation can either be conducted at the unit with a communicating thermostat/diagnostic tool or remotely with mobile app/website when the AWC Communicating Thermostat controls are used.

With an iGate 2 communicating system, users and contractors have a web-enabled gateway to system information never before available and exclusive to ClimateMaster products.

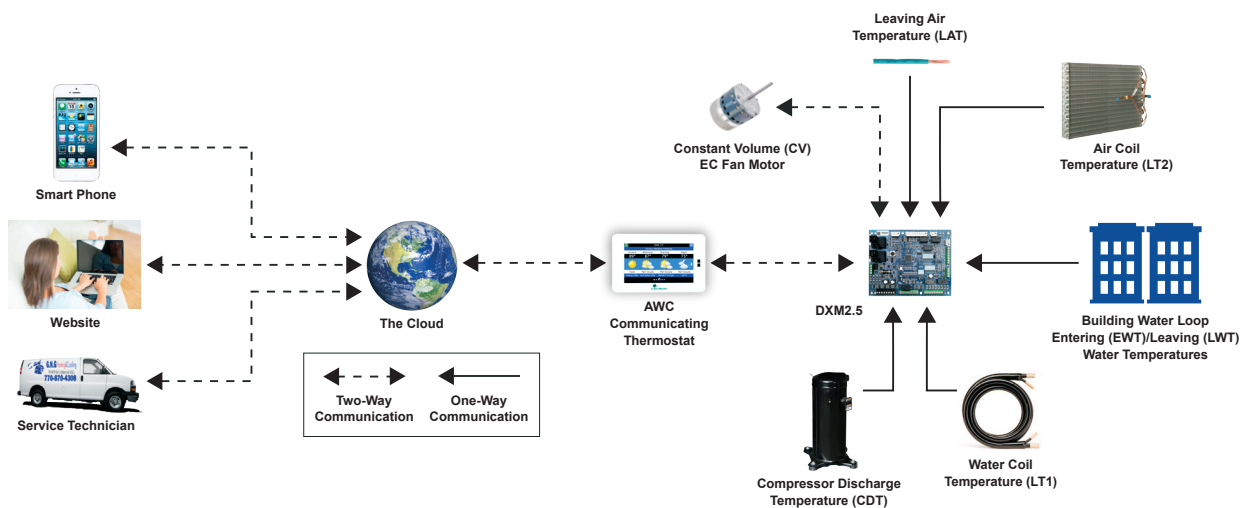

iGate® 2 Communicating (AWC) Thermostat

iGate® 2 Communication – Cloud connected, web-enabled information gateway to monitor, control, and diagnose your system

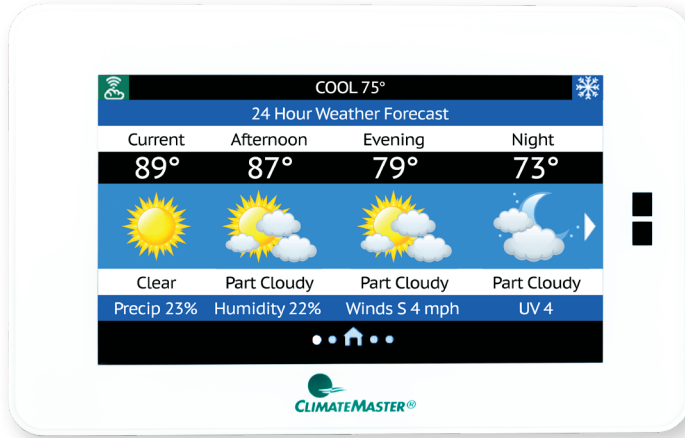

The iGate® 2 Communicating (AWC) Thermostat is innovating the future of comfort technology, one building at a time. The inspired design of the touch screen interface allows you to see real-time data for the efficiency and health of your system, with early warnings for potential system faults. The cloud based information gateway allows technicians to remotely diagnose system issues before occupants even know there is a problem. Control and monitor the system in your home or business from anywhere in the world with an easy to use app on your phone.

Features with Efficiency in Mind



Touch Screen Interface

A brilliantly customizable touch screen monitor for simple control.



Seamless Integration

Between your iGate® 2 Communicating (AWC) Thermostat and Tranquility comfort system.



(Mobile) Remote System Control

Control temperature and schedule from anywhere in the world.



Early Fault Warnings

Alerts you and your contractor of potential system faults in the future.



Remote Diagnostics

Enable the contractor to remotely diagnose system issues, adjust system settings, and reset faults.



Real-Time Operations Data & System Schematics

Access simply via the myUplink Pro Account and web portal to view system diagrams with current operating temperatures.



Revenue Stream

HVAC professionals can offer owners service contracts with remote monitoring and diagnosis capabilities without the large expense of a building management system.



HVAC Professional | User Experience

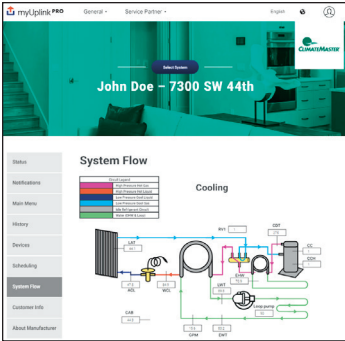

The iGate® 2 is more than just a smart thermostat for your residential or commercial customer, it's a business opportunity. Our new thermostat works with your customers' Tranquility comfort systems to provide the most efficient link between their system and

your services. The customization of monitoring from the myUplink PRO web portal or phone app account allows for continuous system monitoring, analysis, repair recognition, and early warnings for potential system faults that are sent to you and your customer.



Benefits

- Remote login from anywhere, anytime from any internet connected device
- View system fault history with possible root causes
- Information is available for contractors to troubleshoot and diagnosis systems remotely
- Secure internet connection keeps homeowner information private
- Access thermostat(s) through Android and iPhone mobile apps

Homeowner | User Experience

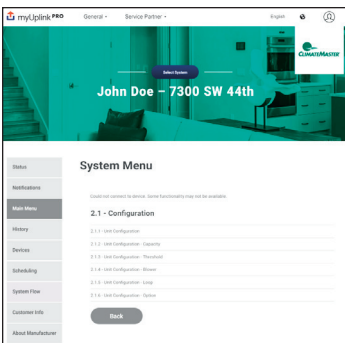

The iGate® 2 combines a Wi-Fi thermostat and advanced unit controls to communicate the systems operation information to the cloud. From any internet connected device or smart phone, homeowners can control and monitor their systems from anywhere in the

world. iGate 2 offers homeowners peace of mind their systems are operating at peak performance with advanced operational performance issue notifications. HVAC professionals get notifications when systems are operating out of range. They can log in remotely to check system faults, review current operating conditions, and diagnosis issues remotely. This gives the HVAC technician the upper hand when showing up to perform service, saving time which in turn saves money.



Benefits

- Communicates personal settings and reminders through the iGate 2 communication system
- Easy-to-use, full-color, high-resolution interface
- Sleek, intuitive button control
- Secure internet connection keeps your information private
- Contains unit model, serial number and your HVAC professionals contact information
- System monitoring automatically contacts HVAC system providers when service is needed

Constant Volume (CV) ECM

The Intelligent Constant Volume (CV) ECM blower motor provides unmatched functionality that saves installing and service technicians time while also providing increased comfort levels to occupants.

CV ECM's are programed to maintain a constant CFM across a wide range of external static pressures (ESP). This functionality differs from traditional PSC or even Constant Torque (CT) ECM's. With traditional PSC and CT ECM fan motors, as ESP is increased CFM is reduced. To increase or decrease the speed of the fan motor requires a fan motor switch or a technician to wire into a different motor tap. CT ECM's provide increased efficiency over PSC motors but with no additional functionality. With a CV ECM, as changes in ESP occur the fan motor will adjust its speed to deliver the desired CFM (within its operating range). This ensures the system is delivering the airflow and capacity it was designed for.

A major benefit of the CV ECM over other fan motor types its ability to adjust airflow remotely through the iGate® 2 web portal/mobile app or directly at the unit with a communicating diagnostic service tool or thermostat. Airflow levels can be adjusted in increments of 25 CFM from the units minimum and maximum CFM range (see CV ECM configuration table for details). This functionality allows technicians to dial in airflow during start-up and commissioning via an easy to use service tool. During operation occupants may have a desire for airflow adjustments. Reducing CFM can reduce airflow sound levels and increase cooling dehumidification (latent capacity). Technicians can easily make these adjustments without making wiring changes reducing service time with minimal disruption to the occupants.

The fan motor operating modes include:

- First Stage Cooling (Y1 & O)
- Second Stage Cooling (Y1, Y2, & O)
- First Stage Heating (Y1)
- Second Stage Heating (Y1 & Y2)
- Fan (G with no Y1, Y2, or W)

The CV ECM motor includes **“soft start”** and **“ramp down”** features. The soft start feature gently increases the motors rpm at blower start up resulting quieter blower start cycles. Likewise, the ramp down feature allows the blower to slowly decrease rpm to a full stop resulting in a quieter end to each blower cycle. The ramp down feature (also known as the heating or cooling “Off Delay”) also has the functionality to be field selected by the technician in the allowable range of 0 to 255 seconds.



Airflow Configuration Screen on Mobile App

Constant Torque (CT) ECM

The Constant Torque (CT) ECM blower motor

combines high efficient airflow movement with simplistic operation.

The CT ECM is designed to maintain a fixed RPM. The delivered unit airflow will depend on the total static applied on the system (ductwork, grilles, etc.). This is similar to the operation of a PSC motor and differs from the CV ECM motor which will adjust RPM to deliver a constant CFM. Also, like a traditional PSC blower motor, the CT ECM blower motor has 4-5 Speed Taps depending on unit size (see blower tables for details). The blower comes factory wired into two speed taps. To adjust speeds in the field a technician manually changes the electrical connection either at the fan motor or connecting wire harness (varies by size).

The blower offers a “soft start” feature. Soft start gently increases the blower motors rpm resulting in quieter operation during start up cycles. The blower does not include a “ramp down” feature like the CV ECM motor. When the fan call is removed the blower will immediately shut down. If the ramp down feature is required please select a CV ECM blower.

The CT ECM blower is not a communicating component and does not contain the high functionality like the CV ECM blower does. It offers an entry level ECM option for applications seeking high efficiency with simplistic functionality. Constant Volume (CV) and Constant Torque (CT) styles of ECM blower motors are both equally efficient in their operation. The difference between the two motors is in their operational functionality.



Speed Taps 1-5



Selection Procedure

Reference Calculations

HEATING	
$LWT = EWT - \frac{HE}{GPM \times Constant}$	
$LAT = EAT + \frac{HC}{CFM \times 1.08}$	

COOLING	
$LWT = EWT + \frac{HR}{GPM \times Constant}$	$LC = TC - SC$
$LAT (DB) = EAT (DB) - \frac{SC}{CFM \times 1.08}$	$S/T = \frac{SC}{TC}$

Constant = 500 for water, 485 for antifreeze

Conversion Table - to convert inch-pound (English) to S-I (Metric)

Airflow	Water Flow	Est Static Pressure	Water Pressure Drop
Airflow (L/s) = CFM x 0.472	Water Flow (L/s) = gpm x 0.0631	ESP (Pa) = ESP (in of wg) x 249	PD (kPa) = PD (ft of hd) x 2.99

Legend and Glossary of Abbreviations

Abbreviations	Descriptions
Btuh	Btu (British Thermal Unit) per hour
CDT	Compressor discharge temperature
CFM	Airflow, cubic feet per minute
COP	Coefficient of performance = Btuh output/Btuh input
CT ECM	Electronic commutated constant torque fan motor
CV ECM	Electronic commutated constant volume fan motor
DB	Dry bulb temperature, °F
EAT	Entering air temperature
EER	Energy efficient ratio = Btuh output/Watt input
ESP	External static pressure, inches w.g.
EWT	Entering water temperature
FPT	Female pipe thread
GPM	Water flow in U.S., gallons per minute
HC	Air heating capacity, Btuh
HE	Total heat of extraction, Btuh
HR	Total heat of rejection, Btuh
HWC	Hot water generator (desuperheater) capacity, MBtuh
kW	Total power unit input, kilowatts
LAT	Leaving air temperature, °F
LC	Latent cooling capacity, Btuh
LOC	Loss of charge
LWT	Leaving water temperature, °F
MBtuh	1,000 Btu per hour
MPT	Male pipe thread
MWV	Motorized water valve
PSC	Permanent split capacitor
RDS	Refrigerant Detection System
SC	Sensible cooling capacity, Btuh
S/T	Sensible to total cooling ratio
TC	Total cooling capacity, Btuh
TD or delta T	Temperature differential
VFD	Variable frequency drive
WB	Wet bulb temperature, °F
WPD	Waterside pressure drop, psi or feet of head
WSE	Waterside economizer

ClimateMaster works continually to improve its products. As a result, the design and specifications of each product at the time of order may be changed without notice and may not be as described herein. Please contact ClimateMaster's Customer Service Department at 1-405-745-6000 for specific information on the current design and specifications. Statements and other information contained herein are not express warranties and do not form the basis of any bargain between the parties, but are merely ClimateMaster's opinion or commendation of its products. The latest version of this document is available at climatemaster.com. © ClimateMaster, Inc. All rights reserved 2009

Selection Procedure

- Step 1** Determine the actual heating and cooling loads at the desired dry bulb and wet bulb conditions.
- Step 2** Obtain the following design parameters: Entering water temperature, water flow rate in GPM, air flow in CFM, water flow pressure drop and design wet and dry bulb temperatures. Air flow CFM should be between 300 and 450 CFM per ton. Unit water pressure drop should be kept as close as possible to each other to make water balancing easier. Go to the appropriate tables and find the proper indicated water flow and water temperature.
- Step 3** Select a unit based on total and sensible cooling conditions. Select a unit which is closest to, but no larger than, the actual cooling load.
- Step 4** Enter tables at the design water flow and water temperature. Read the total and sensible cooling capacities (**Note: interpolation is permissible, extrapolation is not**).
- Step 5** Read the heating capacity. If it exceeds the design criteria it is acceptable. It is quite normal for Water-Source Heat Pumps to be selected on cooling capacity only since the heating output is usually greater than the cooling capacity.
- Step 6** Determine the correction factors associated with the variable factors of dry bulb, wet bulb and air flow.

Corrected Total Cooling = tabulated total cooling x wet bulb correction x air flow correction

Corrected Sensible Cooling = tabulated sensible cooling x dry bulb correction x air flow correction.
- Step 7** Compare the corrected capacities to the load requirements. Normally if the capacities are within 10% of the loads, the equipment is acceptable. It is better to undersize than oversize, as undersizing improves humidity control, reduces sound levels and extends the life of the equipment.
- Step 8** When completed, calculate water temperature rise and assess the selection. If the units selected are not within 10% of the load calculations, then review what effect changing the GPM, water temperature and/or air flow and air temperature would have on the corrected capacities. If the desired capacity cannot be achieved, select the next larger or smaller unit and repeat the procedure. Remember, when in doubt, undersize slightly for best performance.

Example Equipment Selection For Cooling Step 1 Load Determination:

Assume we have determined that the appropriate cooling load at the desired dry bulb 80°F and wet bulb 65°F conditions is as follows:

Total Cooling.....	23,700 BTUH
Sensible Cooling.....	16,500 BTUH
Entering Air Temp.....	80°F Dry Bulb / 65°F Wet Bulb

Step 2 Design Conditions:

Similarly, we have also obtained the following design parameters:

Entering Water Temp.....	90°F
Water Flow (Based upon 10°F rise in temp.).....	6.0 GPM
Air Flow.....	800 CFM

Steps 3, 4 & 5 HP Selection:

After making our preliminary selection (TC024), we enter the tables at design water flow and water temperature and read Total Cooling, Sens. Cooling and Heat of Rej. capacities:

Total Cooling.....	23,400 BTUH
Sensible Cooling.....	17,500 BTUH
Heat of Rejection.....	30,200 BTUH

Steps 6 & 7 Entering Air and Airflow Corrections:

Next, we determine our correction factors.

	Table	Ent Air	Air Flow	Corrected
Corrected Total Cooling =	23,400	x 0.9681	x 1.0050	= 22,767
Corrected Sens Cooling =	17,500	x 1.1213	x 0.9820	= 19,270
Corrected Heat of Rej. =	30,200	x 0.9747	x 1.0434	= 30,713

Step 8 Water Temperature Rise Calculation and Assessment:

Actual Temperature Rise.....	10.2°F
------------------------------	--------

When we compare the Corrected Total Cooling and Corrected Sensible Cooling figures with our load requirements stated in Step 1, we discover that our selection is within +/- 10% of our sensible load requirement. Furthermore, we see that our Corrected Total Cooling figure is within 1,000 Btuh the actual indicated load.

TC Series Nomenclature

1 2 3 4 5 6 7 8 9 10 11 12 13 14 15

TC **H** **036** **A** **G** **C** **3** **0** **A** **P** **B** **S**

S = STANDARD

MODEL TYPE
TC = TRANQUILITY COMPACT R410A

CONFIGURATION
H = HORIZONTAL
V = VERTICAL

UNIT SIZE
006 - E,G
009 - E,G
012 - E,G
015 - E,G
018 - E,G
024 - E,F,GH
030 - E,FGH
036 - E,FGH
041 - F,G,H,N (TCV ONLY)
042 - F,G,H,N
048 - F,G,H,N
060 - F,G,H,N

AVAILABLE VOLTAGES

REVISION LEVEL
A = CURRENT REVISION FOR ALL SIZES

VOLTAGE
G = 208/230/60/1
E = 265/60/1
H = 208/230/60/3
F = 460/60/3
N = 575/60/3

CONTROLS
C = CXM2
D = DXM2.5
N = CXM2 w/MPC
P = DXM2.5 w/MPC

W/DISCONNECT
A = CXM2
B = DXM2.5
R = CXM2 w/MPC
S = DXM2.5 w/MPC

SUPPLY AIR OPTIONS

Option	Supply	Configuration	Motor
T	Top	TCV	PSC
B	Back	TCH	PSC
S	Straight	TCH	PSC
V ¹	Top	TCV	PSC Hi Static
Y ¹	Back	TCH	PSC Hi Static
Z ¹	Straight	TCH	PSC Hi Static
K ²	Top	TCV	CV ECM
P ²	Back	TCH	CV ECM
W ²	Straight	TCH	CV ECM
1 ²	Top	TCV	CT ECM
2 ²	Back	TCH	CT ECM
3 ²	Straight	TCH	CT ECM

¹ Not available for sizes 006, 009, 012, 041
² Not available for size 041
³ DXM2.5 Controls Required for CV ECM Fan Motors

RETURN AIR OPTIONS
P = LEFT RETURN
C = RIGHT RETURN
S = LEFT RETURN S.S. DRAIN PAN
T = RIGHT RETURN S.S. DRAIN PAN
Q = FRONT RETURN S.S. DRAIN PAN and VERTICAL 009-030 AND 041 ONLY

HEAT EXCHANGER OPTIONS

OPTION	COPPER WATER COIL	CUPRO-NICKEL WATER COIL	TIN PLATED AIR COIL	E-COATED ECON COIL	WATER SIDE ECONOMIZER
A	YES	NO	YES	N/A	
C	YES	NO	NO	N/A	NO
J	NO	YES	YES	N/A	
N	NO	YES	NO	N/A	
1	YES	NO	YES	YES	
2	YES	NO	NO	NO	YES
3	NO	YES	YES	YES	
4	NO	YES	NO	NO	

FUTURE USE
0 = NONE

CABINET INSULATION

OPTION	RANGE	ULTRA QUIET	1" FILTER RAIL	2" FILTER RAIL	1" FILTER FRAME	2" FILTER FRAME
1		YES				
A	EXTENDED RANGE	NO	NO	NO	NO	YES
J		NO	YES		NO	
K		NO		YES	NO	
2		YES		NO		
C	YES	NO	NO		YES	
L		NO	YES		NO	
M		NO		YES	NO	
3		YES		NO		
E	STANDARD RANGE	NO	NO	NO	YES	
N		NO	YES		NO	
P		NO		YES	NO	
4		YES		NO		
G	YES	NO	NO		YES	
R		NO	YES		NO	
S		NO		YES	NO	

Note: Above model nomenclature is a general reference. Not all configurations are available on all models. Consult selection software for detailed information.

Performance Data – ASHRAE/AHRI/ISO 13256-1

ASHRAE/AHRI/ISO 13256-1. English (I-P) Units

Model	Fan Motor	Water Loop Heat Pump				Ground Water Heat Pump				Ground Loop Heat Pump			
		Cooling 86°F		Heating 68°F		Cooling 59°F		Heating 50°F		Cooling 77°F		Heating 32°F	
		Capacity Btuh	EER Btuh/W	Capacity Btuh	COP	Capacity Btuh	EER Btuh/W	Capacity Btuh	COP	Capacity Btuh	EER Btuh/W	Capacity Btuh	COP
TC-006	PSC	5,800	13.2	7,500	4.7	7,000	21.1	6,300	4.0	6,200	15.4	4,900	3.1
	ECM	5,800	14.0	7,500	4.8	7,000	24.0	6,300	4.2	6,200	16.7	4,900	3.5
TC-009	PSC	8,600	13.4	11,600	4.3	10,000	21.1	9,700	3.9	9,100	15.7	7,800	3.4
	ECM	8,600	14.2	11,600	4.4	10,000	23.4	9,700	4.0	9,100	16.8	7,800	3.5
TC-012	PSC	11,100	12.5	14,700	4.3	13,500	19.2	12,100	3.7	12,000	14.3	10,000	3.2
	ECM	11,100	13.0	14,700	4.4	13,500	20.0	12,100	3.8	12,000	14.6	10,000	3.3
TC-015	PSC	14,300	14.5	17,100	5.0	16,500	24.0	14,100	4.3	14,800	17.0	11,000	3.5
	ECM	14,300	15.5	17,100	5.3	16,500	25.0	14,100	4.5	14,800	18.0	11,000	3.6
TC-018	PSC	18,700	14.0	21,800	5.0	21,500	22.0	17,800	4.2	19,500	16.1	14,100	3.4
	ECM	18,700	15.0	21,800	5.2	21,500	23.6	17,800	4.5	19,500	17.1	14,100	3.7
TC-024	PSC	23,600	13.0	27,500	4.6	27,000	20.5	23,500	4.1	24,500	15.0	18,600	3.3
	ECM	23,600	13.5	27,500	4.8	27,000	21.5	23,500	4.3	24,500	16.0	18,600	3.5
TC-030	PSC	28,600	13.0	37,000	4.7	32,000	19.6	30,500	4.1	29,500	14.7	24,000	3.4
	ECM	28,600	13.6	37,000	4.9	32,000	21.6	30,500	4.3	29,500	16.0	24,000	3.6
TC-036	PSC	34,500	13.2	45,200	4.4	38,700	20.0	37,000	3.9	35,300	14.5	28,700	3.3
	ECM	34,500	14.0	45,200	4.5	38,700	21.0	37,000	4.0	35,300	15.5	28,700	3.4
TCV-041	PSC	36,500	13.2	45,700	4.3	41,400	19.7	38,000	3.7	38,000	14.8	30,000	3.2
TC-042	PSC	41,000	13.2	52,700	4.3	46,400	19.6	42,400	3.8	42,500	14.5	33,900	3.2
	ECM	41,000	14.9	52,700	4.5	46,400	21.0	42,400	4.0	42,500	16.0	33,900	3.4
TC-048	PSC	48,000	13.3	53,600	4.7	54,200	20.5	45,300	4.1	50,400	14.7	36,500	3.4
	ECM	48,000	14.0	53,600	4.8	54,200	21.0	45,300	4.3	50,400	16.2	36,500	3.6
TC-060	PSC	59,500	13.0	72,000	4.3	66,500	18.7	61,000	3.9	61,500	14.5	49,200	3.3
	ECM	59,500	14.6	72,000	4.4	66,500	20.5	61,000	4.0	61,500	16.5	49,200	3.4

Cooling capacities based upon 80.6°F DB, 66.2°F WB entering air temperature
 Heating capacities based upon 68°F DB, 59°F WB entering air temperature
 All ratings based upon operation at lower voltage of dual voltage rated models

ASHRAE/AHRI/ISO 13256-1. Metric (S-I) Units

Model	Fan Motor	Water Loop Heat Pump				Ground Water Heat Pump				Ground Loop Heat Pump			
		Cooling 30°C		Heating 20°C		Cooling 15°C		Heating 10°C		Full Cooling 25°C		Full Heating 0°C	
		Capacity kW	EER W/W	Capacity kW	COP	Capacity kW	EER W/W	Capacity kW	COP	Capacity kW	EER W/W	Capacity kW	COP
TC-006	PSC	1.70	3.9	2.20	4.7	2.05	6.2	1.84	4.0	1.82	4.5	1.43	3.1
	ECM	1.70	4.1	2.20	4.8	2.05	7.0	1.84	4.2	1.82	4.9	1.43	3.5
TC-009	PSC	2.52	3.9	3.40	4.3	2.93	6.2	2.84	3.9	2.66	4.6	2.28	3.4
	ECM	2.52	4.2	3.40	4.4	2.93	6.9	2.84	4.0	2.66	4.9	2.28	3.5
TC-012	PSC	3.25	3.7	4.30	4.3	3.95	5.6	3.54	3.7	3.51	4.2	2.93	3.2
	ECM	3.25	3.8	4.30	4.4	3.95	5.9	3.54	3.8	3.51	4.3	2.93	3.3
TC-015	PSC	4.19	4.2	5.01	5.0	4.84	7.0	4.13	4.3	4.34	5.0	3.22	3.5
	ECM	4.19	4.5	5.01	5.3	4.84	7.3	4.13	4.5	4.34	5.3	3.22	3.5
TC-018	PSC	5.48	4.1	6.38	5.0	6.30	6.4	5.21	4.2	5.71	4.7	4.13	3.4
	ECM	5.48	4.4	6.38	5.2	6.30	6.9	5.21	4.5	5.71	5.0	4.13	3.7
TC-024	PSC	6.91	3.8	8.05	4.6	7.91	6.0	6.88	4.1	7.17	4.4	5.45	3.3
	ECM	6.91	4.0	8.05	4.8	7.91	6.3	6.88	4.3	7.17	4.7	5.45	3.5
TC-030	PSC	8.37	3.8	10.83	4.7	9.37	5.7	8.93	4.1	8.64	4.3	7.03	3.4
	ECM	8.37	4.0	10.83	4.9	9.37	6.3	8.93	4.3	8.64	4.7	7.03	3.6
TC-036	PSC	10.11	3.9	13.25	4.4	11.34	5.9	11.05	3.9	10.35	4.2	8.41	3.3
	ECM	10.11	4.1	13.25	4.5	11.34	6.2	11.05	4.0	10.35	4.5	8.41	3.4
TCV-041	PSC	10.69	3.9	13.38	4.3	12.12	5.8	11.13	3.7	11.13	4.3	8.78	3.2
TC-042	PSC	12.02	3.9	15.44	4.3	13.60	5.7	12.43	3.8	12.46	4.2	9.94	3.2
	ECM	12.02	4.4	15.44	4.5	13.60	6.2	12.43	4.0	12.46	4.5	9.94	3.4
TC-048	PSC	14.05	3.9	15.69	4.7	15.87	6.0	13.26	4.1	14.76	4.3	10.69	3.4
	ECM	14.05	4.1	15.69	4.8	15.87	6.1	13.26	4.3	14.76	4.7	10.69	3.6
TC-060	PSC	17.42	3.8	21.08	4.3	19.47	5.5	17.86	3.9	18.01	4.2	14.41	3.3
	ECM	17.42	4.3	21.08	4.4	19.47	6.0	17.86	4.0	18.01	4.8	14.41	3.4

Cooling capacities based upon 27°C DB, 19°C WB entering air temperature
 Heating capacities based upon 20°C DB, 15°C WB entering air temperature
 All ratings based upon operation at lower voltage of dual voltage rated models

ClimateMaster works continually to improve its products. As a result, the design and specifications of each product at the time of order may be changed without notice and may not be as described herein. Please contact ClimateMaster's Customer Service Department at 1-405-745-6000 for specific information on the current design and specifications. Statements and other information contained herein do not express warranties and do not form the basis of any bargain between the parties, but are merely ClimateMaster's opinion or commendation of its products. The latest version of this document is available at climatemaster.com. © ClimateMaster, Inc. All rights reserved 2009

Performance Data – Selection Notes

For operation in the shaded area when water is used in lieu of an antifreeze solution, the LWT (Leaving Water Temperature) must be calculated. Flow must be maintained to a level such that the LWT is maintained above 40°F [4.4°C] when the JW3 jumper is not clipped (see example below). Otherwise, appropriate levels of a proper antifreeze solution should be used in systems with leaving water temperatures of 40°F or below and the JW3 jumper should be clipped. This is due to the potential of the refrigerant temperature being as low as 32°F [0°C] with 40°F [4.4°C] LWT, which may lead to a nuisance cutout due to the activation of the Low Temperature Protection. JW3 should never be clipped for standard range equipment or systems without antifreeze.

Example:

At 50°F EWT (Entering Water Temperature) and 2.25 gpm/ton, a 3 ton unit has a HE of 27,300 Btuh. To calculate LWT, rearrange the formula for HE as follows:

HE = TD x GPM x 500, where HE = Heat of Extraction (Btuh); TD = temperature difference (EWT - LWT) and GPM = U.S. Gallons per Minute.

$$TD = HE / (GPM \times 500)$$

$$TD = 27,300 / (6.75 \times 500)$$

$$TD = 8^\circ\text{F}$$

$$\text{LWT} = \text{EWT} - \text{TD}$$

$$\text{LWT} = 50 - 8 = 42^\circ\text{F}$$

In this example, as long as the EWT does not fall below 50°F, the system will operate as designed. For EWTs below 50°F, higher flow rates will be required (open loop systems, for example, require at least 2 gpm/ton when EWT is below 50°F).

Heating - EAT 70°F						
	Airflow CFM	HC	kW	HE	LAT	COP
	860	22.6	2.67	14.1	94	2.49
	1150	23.2	2.39	15.1	89	2.84
23.8	860	25.6	2.80	16.6	98	2.68
23.8	1150	26.2	2.51	17.7	91	3.06
24.7	860	26.8	2.85	17.6	99	2.76
24.7	1150	27.5	2.56	18.8	92	3.15
25.0	860	27.5	2.88	18.2	100	2.80
25.0	1150	28.2	2.59	19.4	93	3.19
21.8	860	30.1	2.98	20.3	102	2.95
21.8	1150	30.8	2.68	21.7	95	3.37
23.3	860	31.6	3.05	21.6	104	3.04
23.3	1150	32.4	2.74	23.1	96	3.47
23.9	860	32.4	3.08	22.3	105	3.09
23.9	1150	33.2	2.77	23.8	97	3.52
19.2	860	34.5	3.16	24.1	107	3.20
19.2	1150	35.4	2.84	25.7	98	3.65
21.0	860	36.3	3.23	25.6	109	3.30
21.0	1150	37.2	2.90	27.3	100	3.76
21.9	860	37.3	3.27	26.4	110	3.35
21.9	1150	38.2	2.93	28.2	101	3.82
16.4	860	38.9	3.32	27.8	112	3.43
16.4	1150	39.8	2.99	29.7	102	3.91
	860	40.9	3.40	29.5	114	3.53
	1150	41.9	3.05	31.5	104	4.02
	860	42.0	3.44	30.4	115	3.58
	1150	43.0	3.09	32.5	105	4.08
		43.1	3.47	31.4	116	3.64
		44.1	3.12	33.5	106	4.14
			3.55	33.2	118	3.70

Performance Data – TC H/V 006 (PSC Blower)

225 CFM Airflow

Performance capacities shown in thousands of Btuh

EWT °F	WPD			Cooling - EAT 80/67°F					Heating - EAT 70°F				
	FLOW GPM	PSI	FT	TC	SC	Power kW	HR	EER	HC	Power kW	HE	LAT	COP
20	0.75	Operation Not Recommended											
	1.13												
	1.50	1.8	4.2						4.0	0.45	2.5	84.6	2.6
30	0.75	0.5	1.1	7.6	5.3	0.28	8.6	27.4	4.6	0.46	3.0	86.8	2.9
	1.13	1.0	2.3	7.8	5.4	0.25	8.6	31.0	4.8	0.47	3.2	87.8	3.0
	1.50	1.6	3.7	7.8	5.4	0.24	8.6	33.0	4.9	0.47	3.3	88.3	3.1
40	0.75	0.4	0.9	7.3	5.2	0.32	8.4	23.3	5.4	0.48	3.8	90.2	3.3
	1.13	0.9	2.0	7.6	5.3	0.29	8.5	26.3	5.7	0.49	4.0	91.4	3.4
	1.50	1.4	3.3	7.6	5.3	0.27	8.6	27.9	5.9	0.49	4.2	92.1	3.5
50	0.75	0.3	0.8	7.0	5.0	0.35	8.2	19.8	6.2	0.50	4.5	93.6	3.7
	1.13	0.8	1.8	7.3	5.1	0.33	8.4	22.3	6.6	0.50	4.9	95.0	3.8
	1.50	1.3	2.9	7.4	5.2	0.31	8.4	23.7	6.8	0.51	5.0	95.8	3.9
60	0.75	0.3	0.7	6.6	4.8	0.39	7.9	16.7	7.0	0.51	5.3	96.9	4.0
	1.13	0.7	1.6	6.9	5.0	0.37	8.1	18.8	7.4	0.52	5.6	98.5	4.2
	1.50	1.2	2.7	7.0	5.0	0.35	8.2	20.0	7.6	0.52	5.8	99.3	4.3
70	0.75	0.3	0.6	6.1	4.6	0.44	7.6	14.0	7.8	0.53	6.0	100.0	4.3
	1.13	0.7	1.5	6.5	4.8	0.41	7.9	15.8	8.2	0.53	6.4	101.7	4.5
	1.50	1.1	2.5	6.6	4.8	0.39	8.0	16.8	8.4	0.54	6.6	102.6	4.6
80	0.75	0.3	0.6	5.6	4.4	0.48	7.3	11.7	8.5	0.54	6.7	102.9	4.6
	1.13	0.6	1.4	6.0	4.5	0.45	7.5	13.2	8.9	0.55	7.0	104.6	4.8
	1.50	1.0	2.4	6.1	4.6	0.44	7.6	14.0	9.1	0.55	7.2	105.4	4.9
85	0.75	0.2	0.6	5.4	4.3	0.51	7.1	10.6	8.8	0.5	6.97	104.2	4.8
	1.13	0.6	1.4	5.7	4.4	0.48	7.3	12.0	9.2	0.6	7.33	105.8	4.9
	1.50	1.0	2.3	5.9	4.5	0.46	7.5	12.8	9.4	0.6	7.50	106.6	5.0
90	0.75	0.2	0.5	5.1	4.1	0.53	6.9	9.6	9.1	0.55	7.3	105.5	4.9
	1.13	0.6	1.3	5.4	4.3	0.50	7.2	10.9	9.5	0.56	7.6	107.0	5.0
	1.50	1.0	2.3	5.6	4.4	0.49	7.3	11.6	9.7	0.56	7.7	107.6	5.0
100	0.75	0.2	0.5	4.6	3.9	0.58	6.6	7.8	Operation Not Recommended				
	1.13	0.5	1.2	4.9	4.0	0.55	6.8	8.9					
	1.50	0.9	2.2	5.1	4.1	0.54	6.9	9.4					
110	0.75	0.2	0.5	4.0	3.6	0.64	6.2	6.2					
	1.13	0.5	1.2	4.3	3.7	0.61	6.4	7.1					
	1.50	0.9	2.0	4.5	3.8	0.59	6.5	7.6					
120	0.75	0.2	0.4	3.4	3.2	0.70	5.8	4.9					
	1.13	0.5	1.1	3.7	3.4	0.67	6.0	5.6					
	1.50	0.8	1.9	3.9	3.5	0.65	6.1	5.9					

Interpolation is permissible; extrapolation is not.
 All entering air conditions are 80°F DB and 67°F WB in cooling, and 70°F DB in heating.
 Table does not reflect fan or pump power corrections for AHR/ISO conditions.
 All performance is based upon the lower voltage of dual voltage rated units.
 Performance stated is at the rated power supply; performance may vary as the power supply varies from the rated.
 Operation below 40°F EWT is based upon a 15% methanol antifreeze solution.
 Operation below 60°F EWT requires optional insulated water/refrigerant circuit.
 See performance correction tables for operating conditions other than those listed above.
 See Performance Data Selection Notes for operation in the shaded areas.

Performance Data – TC H/V 006 (ECM Blower)

225 CFM Airflow

Performance capacities shown in thousands of Btuh

EWT °F	WPD			Cooling - EAT 80/67°F					Heating - EAT 70°F				
	FLOW GPM	PSI	FT	TC	SC	Power kW	HR	EER	HC	Power kW	HE	LAT	COP
20	0.75	Operation Not Recommended											
	1.13												
	1.50	1.8	4.2						3.9	0.42	2.5	84.1	2.8
30	0.75	0.5	1.1	7.6	5.3	0.24	8.4	31.3	4.5	0.43	3.0	86.3	3.0
	1.13	1.0	2.3	7.8	5.4	0.22	8.5	36.0	4.7	0.43	3.2	87.3	3.2
	1.50	1.6	3.7	7.8	5.4	0.20	8.5	38.7	4.8	0.44	3.3	87.8	3.2
40	0.75	0.4	0.9	7.3	5.2	0.28	8.3	26.2	5.3	0.45	3.8	89.7	3.5
	1.13	0.9	2.0	7.6	5.3	0.25	8.4	29.9	5.6	0.45	4.0	90.9	3.6
	1.50	1.4	3.3	7.6	5.3	0.24	8.5	32.0	5.7	0.46	4.2	91.6	3.7
50	0.75	0.3	0.8	7.0	5.0	0.32	8.1	21.9	6.1	0.46	4.5	93.1	3.9
	1.13	0.8	1.8	7.3	5.1	0.29	8.3	25.0	6.5	0.47	4.9	94.5	4.0
	1.50	1.3	2.9	7.4	5.2	0.28	8.3	26.7	6.7	0.47	5.0	95.3	4.1
60	0.75	0.3	0.7	6.6	4.8	0.36	7.8	18.3	6.9	0.48	5.3	96.4	4.2
	1.13	0.7	1.6	6.9	5.0	0.33	8.0	20.8	7.3	0.48	5.6	98.0	4.4
	1.50	1.2	2.7	7.0	5.0	0.32	8.1	22.2	7.5	0.49	5.8	98.8	4.5
70	0.75	0.3	0.6	6.1	4.6	0.40	7.5	15.2	7.7	0.49	6.0	99.5	4.6
	1.13	0.7	1.5	6.5	4.8	0.37	7.7	17.3	8.1	0.50	6.4	101.2	4.8
	1.50	1.1	2.5	6.6	4.8	0.36	7.8	18.5	8.3	0.50	6.6	102.1	4.9
80	0.75	0.3	0.6	5.6	4.4	0.45	7.2	12.6	8.4	0.50	6.7	102.4	4.9
	1.13	0.6	1.4	6.0	4.5	0.42	7.4	14.3	8.8	0.51	7.0	104.1	5.0
	1.50	1.0	2.4	6.1	4.6	0.40	7.5	15.3	9.0	0.51	7.2	104.9	5.1
85	0.75	0.2	0.6	5.4	4.3	0.47	7.0	11.4	8.7	0.5	7.0	103.8	5.0
	1.13	0.6	1.4	5.7	4.4	0.44	7.2	12.9	9.1	0.5	7.3	105.3	5.2
	1.50	1.0	2.3	5.9	4.5	0.43	7.3	13.8	9.3	0.5	7.5	106.1	5.2
90	0.75	0.2	0.5	5.1	4.1	0.50	6.8	10.3	9.0	0.51	7.3	105.0	5.1
	1.13	0.6	1.3	5.4	4.3	0.47	7.0	11.7	9.4	0.52	7.6	106.5	5.2
	1.50	1.0	2.3	5.6	4.4	0.45	7.2	12.5	9.5	0.53	7.7	107.2	5.3
100	0.75	0.2	0.5	4.6	3.9	0.55	6.4	8.3	Operation Not Recommended				
	1.13	0.5	1.2	4.9	4.0	0.52	6.7	9.5					
	1.50	0.9	2.2	5.1	4.1	0.50	6.8	10.1					
110	0.75	0.2	0.5	4.0	3.6	0.60	6.1	6.6					
	1.13	0.5	1.2	4.3	3.7	0.57	6.3	7.5					
	1.50	0.9	2.0	4.5	3.8	0.56	6.4	8.0					
120	0.75	0.2	0.4	3.4	3.2	0.67	5.7	5.1					
	1.13	0.5	1.1	3.7	3.4	0.63	5.9	5.9					
	1.50	0.8	1.9	3.9	3.5	0.62	6.0	6.3					

Interpolation is permissible; extrapolation is not.
 All entering air conditions are 80°F DB and 67°F WB in cooling, and 70°F DB in heating.
 Table does not reflect fan or pump power corrections for AHRI/ISO conditions.
 All performance is based upon the lower voltage of dual voltage rated units.
 Performance stated is at the rated power supply; performance may vary as the power supply varies from the rated.
 Operation below 40°F EWT is based upon a 15% methanol antifreeze solution.
 Operation below 60°F EWT requires optional insulated water/refrigerant circuit.
 See performance correction tables for operating conditions other than those listed above.
 See Performance Data Selection Notes for operation in the shaded areas.

Performance Data – TC H/V 009 (PSC Blower)

325 CFM Airflow

Performance capacities shown in thousands of Btuh

EWT °F	WPD			Cooling - EAT 80/67°F					Heating - EAT 70°F				
	FLOW GPM	PSI	FT	TC	SC	Power kW	HR	EER	HC	Power kW	HE	LAT	COP
20	1.13	Operation Not Recommended											
	1.69												
	2.25	4.3	10.0						6.5	0.71	4.1	86.6	2.7
30	1.13	1.3	3.0	10.6	7.2	0.41	12.0	25.9	7.2	0.73	4.7	88.4	2.9
	1.69	2.5	5.8	10.7	7.2	0.37	12.0	28.8	7.5	0.74	5.0	89.3	3.0
	2.25	3.8	8.8	10.7	7.2	0.35	11.9	30.5	7.7	0.74	5.1	89.8	3.0
40	1.13	1.2	2.7	10.3	7.0	0.47	11.9	22.2	8.2	0.76	5.6	91.3	3.2
	1.69	2.2	5.2	10.5	7.1	0.43	12.0	24.8	8.6	0.76	5.9	92.3	3.3
	2.25	3.4	7.9	10.6	7.2	0.41	12.0	26.2	8.8	0.77	6.1	92.9	3.3
50	1.13	1.0	2.3	9.9	6.8	0.52	11.7	19.1	9.2	0.78	6.5	94.1	3.4
	1.69	2.0	4.6	10.2	7.0	0.48	11.9	21.3	9.6	0.79	6.9	95.3	3.6
	2.25	3.1	7.1	10.4	7.0	0.46	11.9	22.5	9.8	0.80	7.1	95.9	3.6
60	1.13	0.9	2.1	9.4	6.6	0.58	11.4	16.3	10.2	0.81	7.4	96.9	3.7
	1.69	1.8	4.2	9.8	6.8	0.54	11.6	18.2	10.6	0.82	7.8	98.2	3.8
	2.25	2.9	6.6	10.0	6.8	0.52	11.7	19.2	10.9	0.83	8.1	98.9	3.8
70	1.13	0.8	1.9	8.9	6.3	0.64	11.0	13.8	11.2	0.84	8.3	99.7	3.9
	1.69	1.7	3.9	9.3	6.5	0.60	11.3	15.4	11.7	0.86	8.7	101.1	4.0
	2.25	2.7	6.1	9.5	6.6	0.58	11.4	16.3	11.9	0.87	9.0	101.9	4.0
80	1.13	0.8	1.8	8.2	6.0	0.71	10.6	11.6	12.1	0.87	9.1	102.5	4.1
	1.69	1.6	3.6	8.6	6.2	0.67	10.9	13.0	12.7	0.90	9.6	104.0	4.1
	2.25	2.5	5.8	8.8	6.3	0.64	11.0	13.8	13.0	0.91	9.9	104.9	4.2
85	1.13	0.7	1.7	7.9	5.8	0.74	10.4	10.6	12.6	0.9	9.55	103.8	4.1
	1.69	1.5	3.5	8.3	6.0	0.70	10.7	11.9	13.2	0.9	10.04	105.5	4.2
	2.25	2.4	5.6	8.5	6.1	0.68	10.8	12.6	13.5	0.9	10.29	106.4	4.2
90	1.13	0.7	1.7	7.5	5.6	0.78	10.2	9.6	13.1	0.92	10.0	105.2	4.2
	1.69	1.4	3.3	7.9	5.8	0.73	10.4	10.8	13.7	0.95	10.4	106.9	4.2
	2.25	2.4	5.5	8.2	6.0	0.71	10.6	11.5	14.0	0.97	10.7	107.8	4.2
100	1.13	0.7	1.6	6.7	5.2	0.86	9.7	7.9	Operation Not Recommended				
	1.69	1.4	3.1	7.2	5.4	0.81	10.0	8.9					
	2.25	2.3	5.2	7.4	5.6	0.79	10.1	9.4					
110	1.13	0.6	1.4	6.0	4.7	0.94	9.2	6.4					
	1.69	1.3	3.0	6.4	5.0	0.89	9.4	7.2					
	2.25	2.1	4.9	6.6	5.1	0.87	9.6	7.7					
120	1.13	0.6	1.3	5.2	4.3	1.03	8.7	5.0					
	1.69	1.2	2.8	5.6	4.5	0.98	8.9	5.7					
	2.25	1.9	4.5	5.8	4.7	0.95	9.1	6.1					

Interpolation is permissible; extrapolation is not.
 All entering air conditions are 80°F DB and 67°F WB in cooling, and 70°F DB in heating.
 Table does not reflect fan or pump power corrections for AHRI/ISO conditions.
 All performance is based upon the lower voltage of dual voltage rated units.
 Performance stated is at the rated power supply; performance may vary as the power supply varies from the rated.
 Operation below 40°F EWT is based upon a 15% methanol antifreeze solution.
 Operation below 60°F EWT requires optional insulated water/refrigerant circuit.
 See performance correction tables for operating conditions other than those listed above.
 See Performance Data Selection Notes for operation in the shaded areas.

Performance Data – TC H/V 009 (ECM Blower)

325 CFM Airflow

Performance capacities shown in thousands of Btuh

EWT °F	WPD			Cooling - EAT 80/67°F					Heating - EAT 70°F				
	FLOW GPM	PSI	FT	TC	SC	Power kW	HR	EER	HC	Power kW	HE	LAT	COP
20	1.13	Operation Not Recommended											
	1.69												
	2.25	4.3	10.0						6.5	0.68	4.1	86.3	2.8
30	1.13	1.3	3.0	10.6	7.2	0.38	11.9	27.6	7.1	0.70	4.7	88.2	3.0
	1.69	2.5	5.8	10.7	7.2	0.34	11.9	31.0	7.4	0.71	5.0	89.0	3.1
	2.25	3.8	8.8	10.7	7.2	0.33	11.8	32.9	7.6	0.71	5.1	89.5	3.1
40	1.13	1.2	2.7	10.3	7.0	0.44	11.8	23.5	8.1	0.73	5.6	91.1	3.3
	1.69	2.2	5.2	10.5	7.1	0.40	11.9	26.4	8.5	0.74	5.9	92.1	3.4
	2.25	3.4	7.9	10.6	7.2	0.38	11.9	28.0	8.7	0.74	6.1	92.6	3.4
50	1.13	1.0	2.3	9.9	6.8	0.50	11.6	20.1	9.1	0.76	6.5	93.9	3.5
	1.69	2.0	4.6	10.2	7.0	0.46	11.8	22.5	9.5	0.77	6.9	95.1	3.6
	2.25	3.1	7.1	10.4	7.0	0.44	11.8	23.8	9.7	0.77	7.1	95.7	3.7
60	1.13	0.9	2.1	9.4	6.6	0.55	11.3	17.0	10.1	0.78	7.4	96.7	3.8
	1.69	1.8	4.2	9.8	6.8	0.51	11.5	19.1	10.6	0.80	7.8	98.0	3.9
	2.25	2.9	6.6	10.0	6.8	0.49	11.6	20.2	10.8	0.80	8.1	98.7	3.9
70	1.13	0.8	1.9	8.9	6.3	0.62	11.0	14.4	11.1	0.81	8.3	99.5	4.0
	1.69	1.7	3.9	9.3	6.5	0.57	11.2	16.1	11.6	0.83	8.7	100.9	4.1
	2.25	2.7	6.1	9.5	6.6	0.55	11.3	17.1	11.8	0.84	9.0	101.7	4.1
80	1.13	0.8	1.8	8.2	6.0	0.68	10.5	12.0	12.0	0.85	9.1	102.2	4.2
	1.69	1.6	3.6	8.6	6.2	0.64	10.8	13.5	12.6	0.87	9.6	103.8	4.2
	2.25	2.5	5.8	8.8	6.3	0.62	11.0	14.3	12.9	0.89	9.9	104.6	4.3
85	1.13	0.7	1.7	7.9	5.8	0.72	10.3	10.9	12.5	0.9	9.6	103.6	4.2
	1.69	1.5	3.5	8.3	6.0	0.67	10.6	12.3	13.1	0.9	10.0	105.2	4.3
	2.25	2.4	5.6	8.5	6.1	0.65	10.7	13.1	13.4	0.9	10.3	106.1	4.3
90	1.13	0.7	1.7	7.5	5.6	0.75	10.1	9.9	13.0	0.89	10.0	104.9	4.3
	1.69	1.4	3.3	7.9	5.8	0.71	10.4	11.2	13.6	0.93	10.4	106.7	4.3
	2.25	2.4	5.5	8.2	6.0	0.69	10.5	11.9	13.9	0.94	10.7	107.6	4.3
100	1.13	0.7	1.6	6.7	5.2	0.83	9.6	8.1	Operation Not Recommended				
	1.69	1.4	3.1	7.2	5.4	0.78	9.9	9.2					
	2.25	2.3	5.2	7.4	5.6	0.76	10.0	9.8					
110	1.13	0.6	1.4	6.0	4.7	0.91	9.1	6.5	Operation Not Recommended				
	1.69	1.3	3.0	6.4	5.0	0.86	9.4	7.4					
	2.25	2.1	4.9	6.6	5.1	0.84	9.5	7.9					
120	1.13	0.6	1.3	5.2	4.3	1.00	8.6	5.2	Operation Not Recommended				
	1.69	1.2	2.8	5.6	4.5	0.95	8.9	5.9					
	2.25	1.9	4.5	5.8	4.7	0.93	9.0	6.3					

Interpolation is permissible; extrapolation is not.
 All entering air conditions are 80°F DB and 67°F WB in cooling, and 70°F DB in heating.
 Table does not reflect fan or pump power corrections for AHR/ISO conditions.
 All performance is based upon the lower voltage of dual voltage rated units.
 Performance stated is at the rated power supply; performance may vary as the power supply varies from the rated.
 Operation below 40°F EWT is based upon a 15% methanol antifreeze solution.
 Operation below 60°F EWT requires optional insulated water/refrigerant circuit.
 See performance correction tables for operating conditions other than those listed above.
 See Performance Data Selection Notes for operation in the shaded areas.

Performance Data – TC H/V 012 (PSC Blower)

375 CFM Airflow

Performance capacities shown in thousands of Btuh

EWT °F	WPD			Cooling - EAT 80/67°F					Heating - EAT 70°F				
	FLOW GPM	PSI	FT	TC	SC	Power kW	HR	EER	HC	Power kW	HE	LAT	COP
20	3.00	8.5	19.6	Operation Not Recommended					Operation Not Recommended				
30	1.50	1.9	4.4	14.8	9.3	0.57	16.8	25.8	9.5	0.90	6.40	91.9	3.1
	2.25	3.6	8.3	14.9	9.3	0.53	16.7	27.9	9.9	0.91	6.80	92.8	3.2
	3.00	6.7	15.5	14.9	9.3	0.52	16.6	28.8	10.1	0.92	7.00	93.3	3.2
40	1.50	1.4	3.2	14.5	9.2	0.63	16.7	22.9	10.8	0.93	7.60	95.0	3.4
	2.25	3.0	6.9	14.8	9.3	0.59	16.8	25.1	11.3	0.94	8.10	96.2	3.5
	3.00	5.7	13.2	14.8	9.3	0.57	16.8	26.2	11.6	0.95	8.30	96.8	3.6
50	1.50	1.1	2.5	14.1	8.9	0.70	16.5	20.1	12.2	0.97	8.90	98.2	3.7
	2.25	2.6	6.0	14.4	9.1	0.65	16.7	22.2	12.8	0.98	9.50	99.6	3.8
	3.00	5.0	11.6	14.6	9.2	0.63	16.7	23.3	13.1	0.99	9.80	100.4	3.9
60	1.50	0.9	2.1	13.5	8.6	0.77	16.1	17.4	13.6	1.00	10.2	101.5	4.0
	2.25	2.3	5.3	13.9	8.8	0.72	16.4	19.3	14.3	1.02	10.8	103.1	4.1
	3.00	4.5	10.4	14.1	8.9	0.69	16.5	20.4	14.7	1.03	11.2	104.0	4.2
70	1.50	0.8	1.8	12.7	8.3	0.85	15.6	14.9	15.0	1.04	11.5	104.8	4.2
	2.25	2.1	4.9	13.1	8.4	0.80	15.8	16.3	15.8	1.06	12.2	106.5	4.4
	3.00	4.1	9.5	13.3	8.5	0.78	15.9	17.0	16.2	1.07	12.5	107.5	4.4
80	1.50	0.7	1.6	11.9	7.9	0.94	15.1	12.7	16.4	1.08	12.7	108.0	4.5
	2.25	1.9	4.4	12.3	8.0	0.88	15.3	13.9	17.2	1.10	13.4	109.8	4.6
	3.00	3.8	8.8	12.5	8.1	0.86	15.4	14.5	17.6	1.11	13.8	110.7	4.6
85	1.50	0.6	1.4	11.4	7.7	0.98	14.7	11.7	17.0	1.10	13.3	109.4	4.6
	2.25	1.8	4.2	11.9	7.9	0.93	15.0	12.8	17.8	1.10	14.0	111.2	4.6
	3.00	3.7	8.5	12.1	7.9	0.90	15.1	13.4	18.2	1.10	14.3	112.1	4.7
90	1.50	0.6	1.4	10.9	7.5	1.03	14.4	10.7	17.7	1.12	13.9	110.9	4.6
	2.25	1.8	4.2	11.4	7.7	0.97	14.7	11.7	18.4	1.15	14.5	112.6	4.7
	3.00	3.6	8.3	11.6	7.7	0.95	14.8	12.3	18.8	1.16	14.8	113.5	4.7
100	1.50	0.5	1.2	9.9	7.2	1.12	13.8	8.9	Operation Not Recommended				
	2.25	1.7	3.9	10.5	7.3	1.06	14.1	9.8					
	3.00	3.3	7.6	10.8	7.5	1.04	14.3	10.4					
110	1.50	0.5	1.2	8.9	6.8	1.22	13.1	7.3					
	2.25	1.6	3.7	9.4	7.0	1.16	13.4	8.1					
	3.00	3.2	7.4	9.8	7.1	1.14	13.7	8.6					
120	1.50	0.4	0.9	7.8	6.4	1.32	12.3	5.9					
	2.25	1.5	3.5	8.3	6.6	1.27	12.7	6.6					
	3.00	3.0	6.9	8.7	6.7	1.24	12.9	7.0					

Interpolation is permissible; extrapolation is not.
 All entering air conditions are 80°F DB and 67°F WB in cooling, and 70°F DB in heating.
 Table does not reflect fan or pump power corrections for AHR/ISO conditions.
 All performance is based upon the lower voltage of dual voltage rated units.
 Performance stated is at the rated power supply; performance may vary as the power supply varies from the rated.
 Operation below 40°F EWT is based upon a 15% methanol antifreeze solution.
 Operation below 60°F EWT requires optional insulated water/refrigerant circuit.
 See performance correction tables for operating conditions other than those listed above.
 See Performance Data Selection Notes for operation in the shaded areas.

Performance Data – TC H/V 012 (ECM Blower)

375 CFM Airflow

Performance capacities shown in thousands of Btuh

EWT °F	WPD			Cooling - EAT 80/67°F					Heating - EAT 70°F				
	FLOW GPM	PSI	FT	TC	SC	Power kW	HR	EER	HC	Power kW	HE	LAT	COP
20	3.00	8.5	19.6	Operation Not Recommended					8.7	0.85	5.7	90.2	3.0
30	1.50	1.9	4.4	14.8	9.3	0.54	16.6	27.4	9.5	0.87	6.4	91.9	3.2
	2.25	3.6	8.3	14.9	9.3	0.50	16.6	29.8	9.9	0.88	6.8	92.8	3.3
	3.00	6.7	15.5	14.9	9.3	0.49	16.6	30.4	10.1	0.89	7.0	93.3	3.3
40	1.50	1.4	3.2	14.5	9.2	0.60	16.5	24.2	10.8	0.90	7.6	95.0	3.5
	2.25	3.0	6.9	14.8	9.3	0.56	16.7	26.4	11.3	0.91	8.1	96.2	3.6
	3.00	5.7	13.2	14.8	9.3	0.54	16.6	27.4	11.6	0.92	8.3	96.8	3.7
50	1.50	1.1	2.5	14.1	8.9	0.67	16.4	21.0	12.2	0.94	8.9	98.2	3.8
	2.25	2.6	6.0	14.4	9.1	0.62	16.5	23.2	12.8	0.95	9.5	99.6	3.9
	3.00	5.0	11.6	14.6	9.2	0.60	16.6	24.3	13.1	0.96	9.8	100.4	4.0
60	1.50	0.9	2.1	13.5	8.6	0.74	16.0	18.2	13.6	0.97	10.2	101.5	4.1
	2.25	2.3	5.3	13.9	8.8	0.69	16.3	20.1	14.3	0.99	10.8	103.1	4.2
	3.00	4.5	10.4	14.1	8.9	0.66	16.4	21.4	14.7	1.00	11.2	104.0	4.3
70	1.50	0.8	1.8	12.7	8.3	0.82	15.5	15.5	15.0	1.01	11.5	104.8	4.4
	2.25	2.1	4.9	13.1	8.4	0.77	15.7	17.0	15.8	1.03	12.2	106.5	4.5
	3.00	4.1	9.5	13.3	8.5	0.75	15.9	17.7	16.2	1.04	12.5	107.5	4.6
80	1.50	0.7	1.6	11.9	7.9	0.91	15.0	13.1	16.4	1.05	12.7	108.0	4.6
	2.25	1.9	4.4	12.3	8.0	0.85	15.2	14.5	17.2	1.07	13.4	109.8	4.7
	3.00	3.8	8.8	12.5	8.1	0.83	15.3	15.1	17.6	1.08	13.8	110.7	4.8
85	1.50	0.6	1.4	11.4	7.7	0.95	14.6	12.0	17.1	1.07	13.3	109.5	4.7
	2.25	1.8	4.2	11.9	7.9	0.90	15.0	13.2	17.8	1.10	14.0	111.2	4.8
	3.00	3.7	8.5	12.1	7.9	0.87	15.1	13.9	18.2	1.11	14.3	112.1	4.9
90	1.50	0.6	1.4	10.9	7.5	1.00	14.3	10.9	17.7	1.09	13.9	110.9	4.8
	2.25	1.8	4.2	11.4	7.7	0.94	14.6	12.1	18.4	1.12	14.5	112.6	4.8
	3.00	3.6	8.3	11.6	7.7	0.92	14.7	12.6	18.8	1.13	14.8	113.5	4.9
100	1.50	0.5	1.2	9.9	7.2	1.09	13.6	9.1	Operation Not Recommended				
	2.25	1.7	3.9	10.5	7.3	1.03	14.0	10.2					
	3.00	3.3	7.6	10.8	7.5	1.01	14.2	10.7					
110	1.50	0.5	1.2	8.9	6.8	1.19	13.0	7.5					
	2.25	1.6	3.7	9.4	7.0	1.13	13.3	8.3					
	3.00	3.2	7.4	9.8	7.1	1.11	13.6	8.8					
120	1.50	0.4	0.9	7.8	6.4	1.29	12.2	6.0					
	2.25	1.5	3.5	8.3	6.6	1.24	12.5	6.7					
	3.00	3.0	6.9	8.7	6.7	1.21	12.8	7.2					

Interpolation is permissible; extrapolation is not.

All entering air conditions are 80°F DB and 67°F WB in cooling, and 70°F DB in heating.

Table does not reflect fan or pump power corrections for AHR/ISO conditions.

All performance is based upon the lower voltage of dual voltage rated units.

Performance stated is at the rated power supply; performance may vary as the power supply varies from the rated.

Operation below 40°F EWT is based upon a 15% methanol antifreeze solution.

Operation below 60°F EWT requires optional insulated water/refrigerant circuit.

See performance correction tables for operating conditions other than those listed above.

See Performance Data Selection Notes for operation in the shaded areas.

Performance Data – TC H/V 015 (PSC Blower)

525 CFM Airflow

Performance capacities shown in thousands of Btuh

EWT °F	WPD			Cooling - EAT 80/67°F					Heating - EAT 70°F				
	FLOW GPM	PSI	FT	TC	SC	Power kW	HR	EER	HC	Power kW	HE	LAT	COP
20	3.75	4.4	10.2	Operation Not Recommended					9.2	0.96	6.1	84.2	2.9
30	1.88	0.5	1.3	16.7	12.3	0.68	19.0	24.3	10.1	0.98	6.9	85.7	3.1
	2.81	1.3	3.1	16.7	12.2	0.61	18.8	27.2	10.6	0.99	7.3	86.6	3.2
	3.75	2.3	5.4	16.7	12.0	0.58	18.6	28.6	10.8	0.99	7.5	87.0	3.3
40	1.88	0.5	1.2	16.3	12.1	0.77	18.9	21.1	11.5	1.01	8.2	88.3	3.5
	2.81	1.3	2.9	16.6	12.3	0.70	19.0	23.9	12.1	1.02	8.8	89.3	3.6
	3.75	2.1	4.9	16.7	12.3	0.66	19.0	25.3	12.5	1.03	9.1	89.9	3.7
50	1.88	0.5	1.1	15.7	11.8	0.86	18.7	18.2	13.0	1.04	9.6	91.0	3.8
	2.81	1.2	2.7	16.2	12.1	0.78	18.9	20.7	13.7	1.05	10.3	92.2	4.0
	3.75	2.0	4.6	16.4	12.2	0.74	19.0	22.1	14.1	1.06	10.6	92.9	4.1
60	1.88	0.5	1.0	15.0	11.4	0.96	18.3	15.6	14.6	1.07	11.1	93.6	4.1
	2.81	1.1	2.5	15.6	11.8	0.88	18.6	17.8	15.4	1.08	11.8	95.1	4.3
	3.75	1.9	4.3	15.9	11.9	0.84	18.8	19.0	15.8	1.09	12.2	95.8	4.4
70	1.88	0.4	1.0	14.1	10.9	1.07	17.8	13.3	16.1	1.09	12.5	96.3	4.5
	2.81	1.0	2.3	14.8	11.3	0.98	18.2	15.1	17.0	1.11	13.3	97.9	4.7
	3.75	1.7	4.0	15.2	11.5	0.94	18.4	16.2	17.5	1.12	13.8	98.8	4.8
80	1.88	0.4	0.9	13.2	10.5	1.17	17.2	11.2	17.6	1.12	13.9	99.0	4.8
	2.81	0.9	2.1	13.9	10.9	1.09	17.7	12.8	18.6	1.13	14.8	100.7	5.0
	3.75	1.6	3.7	14.3	11.0	1.04	17.9	13.7	19.1	1.14	15.4	101.6	5.1
85	1.88	0.4	0.8	12.7	10.3	1.23	16.9	10.3	18.3	1.13	14.6	100.3	4.9
	2.81	0.9	2.0	13.5	10.6	1.14	17.3	11.8	19.3	1.14	15.6	102.0	5.1
	3.75	1.5	3.6	13.8	10.8	1.10	17.6	12.6	19.9	1.15	16.1	103.0	5.2
90	1.88	0.4	0.8	12.2	10.1	1.28	16.6	9.5	19.1	1.14	15.3	101.6	5.1
	2.81	0.9	2.0	13.0	10.4	1.20	17.0	10.8	20.1	1.16	16.3	103.4	5.3
	3.75	1.5	3.4	13.4	10.6	1.15	17.3	11.6	20.7	1.16	16.8	104.4	5.4
100	1.88	0.3	0.8	11.2	9.7	1.40	16.0	8.0	Operation Not Recommended				
	2.81	0.8	1.9	11.9	9.9	1.31	16.4	9.1					
	3.75	1.4	3.2	12.3	10.1	1.27	16.6	9.7					
110	1.88	0.3	0.8	10.2	9.4	1.51	15.4	6.7					
	2.81	0.8	1.7	10.9	9.6	1.43	15.8	7.6					
	3.75	1.3	3.0	11.3	9.7	1.39	16.0	8.1					
120	1.88	0.3	0.7	9.3	9.2	1.63	14.8	5.7					
	2.81	0.7	1.6	9.9	9.3	1.55	15.2	6.4					
	3.75	1.2	2.9	10.2	9.4	1.51	15.4	6.8					

Interpolation is permissible; extrapolation is not.
 All entering air conditions are 80°F DB and 67°F WB in cooling, and 70°F DB in heating.
 Table does not reflect fan or pump power corrections for AHR/ISO conditions.
 All performance is based upon the lower voltage of dual voltage rated units.
 Performance stated is at the rated power supply; performance may vary as the power supply varies from the rated.
 Operation below 40°F EWT is based upon a 15% methanol antifreeze solution.
 Operation below 60°F EWT requires optional insulated water/refrigerant circuit.
 See performance correction tables for operating conditions other than those listed above.
 See Performance Data Selection Notes for operation in the shaded areas.

Performance Data – TC H/V 015 (ECM Blower)

525 CFM Airflow

Performance capacities shown in thousands of Btuh

EWT °F	WPD			Cooling - EAT 80/67°F					Heating - EAT 70°F				
	FLOW GPM	PSI	FT	TC	SC	Power kW	HR	EER	HC	Power kW	HE	LAT	COP
20	3.75	4.4	10.2	Operation Not Recommended					9.2	0.92	6.1	84.2	2.9
30	1.88	0.5	1.3	16.7	12.3	0.65	18.9	25.8	10.1	0.94	6.9	85.7	3.1
	2.81	1.3	3.1	16.7	12.2	0.58	18.7	29.0	10.6	0.95	7.3	86.6	3.2
	3.75	2.3	5.4	16.7	12.0	0.54	18.5	30.6	10.8	0.96	7.5	87.0	3.3
40	1.88	0.5	1.2	16.3	12.1	0.73	18.8	22.2	11.5	0.97	8.2	88.3	3.5
	2.81	1.3	2.9	16.6	12.3	0.66	18.9	25.3	12.1	0.98	8.8	89.3	3.6
	3.75	2.1	4.9	16.7	12.3	0.62	18.8	26.9	12.5	0.99	9.1	89.9	3.7
50	1.88	0.5	1.1	15.7	11.8	0.83	18.5	19.0	13.0	1.00	9.6	91.0	3.8
	2.81	1.2	2.7	16.2	12.1	0.75	18.8	21.8	13.7	1.02	10.3	92.2	4.0
	3.75	2.0	4.6	16.4	12.2	0.71	18.8	23.3	14.1	1.02	10.6	92.9	4.1
60	1.88	0.5	1.0	15.0	11.4	0.92	18.1	16.2	14.6	1.03	11.1	93.6	4.1
	2.81	1.1	2.5	15.6	11.8	0.84	18.5	18.6	15.4	1.04	11.8	95.1	4.3
	3.75	1.9	4.3	15.9	11.9	0.80	18.6	19.9	15.8	1.05	12.2	95.8	4.4
70	1.88	0.4	1.0	14.1	10.9	1.03	17.6	13.7	16.1	1.06	12.5	96.3	4.5
	2.81	1.0	2.3	14.8	11.3	0.94	18.1	15.8	17.0	1.07	13.3	97.9	4.7
	3.75	1.7	4.0	15.2	11.5	0.90	18.3	16.9	17.5	1.08	13.8	98.8	4.8
80	1.88	0.4	0.9	13.2	10.5	1.13	17.0	11.6	17.6	1.08	13.9	99.0	4.8
	2.81	0.9	2.1	13.9	10.9	1.05	17.5	13.3	18.6	1.10	14.8	100.7	5.0
	3.75	1.6	3.7	14.3	11.0	1.00	17.7	14.3	19.1	1.10	15.4	101.6	5.1
85	1.88	0.4	0.8	12.7	10.3	1.19	16.7	10.7	18.3	1.09	14.6	100.3	4.9
	2.81	0.9	2.0	13.5	10.6	1.10	17.2	12.2	19.3	1.11	15.6	102.0	5.1
	3.75	1.5	3.6	13.8	10.8	1.06	17.5	13.1	19.9	1.12	16.1	103.0	5.2
90	1.88	0.4	0.8	12.2	10.1	1.24	16.4	9.8	19.1	1.10	15.3	101.6	5.1
	2.81	0.9	2.0	13.0	10.4	1.16	16.9	11.2	20.1	1.12	16.3	103.4	5.3
	3.75	1.5	3.4	13.4	10.6	1.11	17.2	12.0	20.7	1.13	16.8	104.4	5.4
100	1.88	0.3	0.8	11.2	9.7	1.36	15.8	8.2	Operation Not Recommended				
	2.81	0.8	1.9	11.9	9.9	1.27	16.3	9.4					
	3.75	1.4	3.2	12.3	10.1	1.23	16.5	10.0					
110	1.88	0.3	0.8	10.2	9.4	1.47	15.2	6.9					
	2.81	0.8	1.7	10.9	9.6	1.39	15.6	7.8					
	3.75	1.3	3.0	11.3	9.7	1.35	15.9	8.4					
120	1.88	0.3	0.7	9.3	9.2	1.59	14.7	5.8					
	2.81	0.7	1.6	9.9	9.3	1.51	15.1	6.6					
	3.75	1.2	2.9	10.2	9.4	1.47	15.3	7.0					

Interpolation is permissible; extrapolation is not.
 All entering air conditions are 80°F DB and 67°F WB in cooling, and 70°F DB in heating.
 Table does not reflect fan or pump power corrections for AHR/ISO conditions.
 All performance is based upon the lower voltage of dual voltage rated units.
 Performance stated is at the rated power supply; performance may vary as the power supply varies from the rated.
 Operation below 40°F EWT is based upon a 15% methanol antifreeze solution.
 Operation below 60°F EWT requires optional insulated water/refrigerant circuit.
 See performance correction tables for operating conditions other than those listed above.
 See Performance Data Selection Notes for operation in the shaded areas.

Performance Data – TC H/V 018 (PSC Blower)

600 CFM Airflow

Performance capacities shown in thousands of Btuh

EWT °F	WPD			Cooling - EAT 80/67°F					Heating - EAT 70°F				
	FLOW GPM	PSI	FT	TC	SC	Power kW	HR	EER	HC	Power kW	HE	LAT	COP
20	2.25	Operation Not Recommended							Operation Not Recommended				
	3.38	Operation Not Recommended							Operation Not Recommended				
	4.50	9.2	21.3						12.6	1.21	8.6	87.3	3.0
30	2.25	2.7	6.2	21.8	14.8	0.84	24.7	26.0	13.6	1.23	9.5	88.9	3.2
	3.38	5.0	11.5	21.6	14.6	0.79	24.3	27.2	14.1	1.24	10.0	89.7	3.3
	4.50	7.3	16.8	21.4	14.4	0.77	24.0	27.9	14.4	1.25	10.3	90.1	3.4
40	2.25	2.0	4.7	21.7	15.0	0.94	24.9	23.2	15.3	1.27	11.1	91.6	3.5
	3.38	3.9	9.1	21.8	14.9	0.88	24.8	24.9	16.0	1.28	11.8	92.6	3.7
	4.50	6.3	14.5	21.8	14.8	0.85	24.7	25.8	16.4	1.29	12.1	93.2	3.7
50	2.25	1.8	4.1	21.2	14.9	1.05	24.8	20.2	17.2	1.30	12.9	94.5	3.9
	3.38	3.4	7.9	21.6	15.0	0.97	24.9	22.3	18.0	1.32	13.6	95.7	4.0
	4.50	5.5	12.7	21.7	15.0	0.94	24.9	23.2	18.4	1.33	14.0	96.3	4.1
60	2.25	1.6	3.6	20.3	14.5	1.17	24.3	17.4	19.1	1.34	14.6	97.3	4.2
	3.38	3.0	7.0	21.0	14.8	1.08	24.7	19.5	19.9	1.35	15.4	98.7	4.3
	4.50	4.9	11.3	21.3	14.9	1.04	24.8	20.5	20.4	1.36	15.9	99.4	4.4
70	2.25	1.4	3.2	19.3	14.1	1.29	23.7	14.9	20.9	1.37	16.4	100.2	4.5
	3.38	2.8	6.4	20.1	14.5	1.19	24.2	16.9	21.8	1.38	17.2	101.5	4.6
	4.50	4.5	10.3	20.5	14.6	1.15	24.4	17.8	22.2	1.39	17.6	102.2	4.7
80	2.25	1.3	3.0	18.1	13.6	1.43	23.0	12.7	22.6	1.39	18.0	102.8	4.8
	3.38	2.6	6.0	19.1	14.0	1.31	23.6	14.5	23.4	1.40	18.8	104.1	4.9
	4.50	4.2	9.7	19.4	14.2	1.27	23.8	15.3	23.9	1.41	19.2	104.8	5.0
85	2.25	1.3	3.0	17.5	13.3	1.49	22.6	11.8	23.4	1.40	18.7	104.0	4.9
	3.38	2.6	5.9	18.5	13.8	1.38	23.2	13.4	24.2	1.41	19.5	105.2	5.0
	4.50	4.2	9.6	18.9	13.9	1.34	23.4	14.1	24.6	1.42	19.9	105.9	5.1
90	2.25	1.3	3.0	16.9	13.1	1.56	22.2	10.8	24.1	1.41	19.4	105.1	5.0
	3.38	2.6	5.9	17.9	13.5	1.45	22.8	12.4	24.9	1.42	20.1	106.3	5.1
	4.50	4.2	9.6	18.3	13.7	1.40	23.1	13.0	25.2	1.43	20.5	106.8	5.2
100	2.25	1.1	2.6	15.7	12.5	1.71	21.5	9.2	Operation Not Recommended				
	3.38	2.4	5.4	16.7	12.9	1.59	22.1	10.5					
	4.50	3.8	8.7	17.0	13.1	1.55	22.3	11.0					
110	2.25	1.2	2.7	14.6	12.1	1.86	20.9	7.8					
	3.38	2.5	5.7	15.4	12.4	1.74	21.4	8.9					
	4.50	3.8	8.8	15.8	12.6	1.70	21.6	9.3					
120	2.25	1.2	2.9	13.6	11.8	2.02	20.5	6.7					
	3.38	2.7	6.1	14.3	12.0	1.90	20.8	7.5					
	4.50	4.0	9.3	14.6	12.1	1.85	21.0	7.9					

Interpolation is permissible; extrapolation is not.
 All entering air conditions are 80°F DB and 67°F WB in cooling, and 70°F DB in heating.
 Table does not reflect fan or pump power corrections for AHR/ISO conditions.
 All performance is based upon the lower voltage of dual voltage rated units.
 Performance stated is at the rated power supply; performance may vary as the power supply varies from the rated.
 Operation below 40°F EWT is based upon a 15% methanol antifreeze solution.
 Operation below 60°F EWT requires optional insulated water/refrigerant circuit.
 See performance correction tables for operating conditions other than those listed above.
 See Performance Data Selection Notes for operation in the shaded areas.

Performance Data – TC H/V 018 (ECM Blower)

600 CFM Airflow

Performance capacities shown in thousands of Btuh

EWT °F	WPD			Cooling - EAT 80/67°F					Heating - EAT 70°F				
	FLOW GPM	PSI	FT	TC	SC	Power kW	HR	EER	HC	Power kW	HE	LAT	COP
20	2.25	Operation Not Recommended							Operation Not Recommended				
	3.38	Operation Not Recommended							Operation Not Recommended				
	4.50	9.2	21.3						12.6	1.17	8.6	87.3	3.2
30	2.25	2.7	6.2	21.8	14.8	0.80	24.5	27.2	13.6	1.2	9.5	88.9	3.3
	3.38	5.0	11.5	21.6	14.6	0.76	24.2	28.5	14.1	1.2	10.0	89.7	3.4
	4.50	7.3	16.8	21.4	14.4	0.73	23.9	29.3	14.4	1.2	10.3	90.1	3.5
40	2.25	2.0	4.7	21.7	15.0	0.90	24.8	24.1	15.3	1.2	11.1	91.6	3.7
	3.38	3.9	9.1	21.8	14.9	0.84	24.7	26.0	16.0	1.2	11.8	92.6	3.8
	4.50	6.3	14.5	21.8	14.8	0.81	24.6	27.0	16.4	1.2	12.1	93.2	3.8
50	2.25	1.8	4.1	21.2	14.9	1.01	24.6	21.0	17.2	1.3	12.9	94.5	4.0
	3.38	3.4	7.9	21.6	15.0	0.93	24.8	23.1	18.0	1.3	13.6	95.7	4.1
	4.50	5.5	12.7	21.7	15.0	0.90	24.8	24.2	18.4	1.3	14.0	96.3	4.2
60	2.25	1.6	3.6	20.3	14.5	1.13	24.2	18.0	19.1	1.30	14.6	97.3	4.3
	3.38	3.0	7.0	21.0	14.8	1.04	24.5	20.2	19.9	1.31	15.4	98.7	4.5
	4.50	4.9	11.3	21.3	14.9	1.00	24.7	21.2	20.4	1.32	15.9	99.4	4.5
70	2.25	1.4	3.2	19.3	14.1	1.26	23.6	15.3	20.9	1.33	16.4	100.2	4.6
	3.38	2.8	6.4	20.1	14.5	1.15	24.1	17.5	21.8	1.34	17.2	101.5	4.8
	4.50	4.5	10.3	20.5	14.6	1.11	24.3	18.4	22.2	1.35	17.6	102.2	4.8
80	2.25	1.3	3.0	18.1	13.6	1.39	22.8	13.0	22.6	1.35	18.0	102.8	4.9
	3.38	2.6	6.0	19.1	14.0	1.28	23.4	14.9	23.4	1.36	18.8	104.1	5.0
	4.50	4.2	9.7	19.4	14.2	1.24	23.7	15.7	23.9	1.37	19.2	104.8	5.1
85	2.25	1.3	3.0	17.5	13.3	1.45	22.5	12.1	23.4	1.36	18.7	104.0	5.0
	3.38	2.6	5.9	18.5	13.8	1.34	23.1	13.8	24.2	1.37	19.5	105.2	5.2
	4.50	4.2	9.6	18.9	13.9	1.30	23.3	14.5	24.6	1.38	19.9	105.9	5.2
90	2.25	1.3	3.0	16.9	13.1	1.52	22.1	11.1	24.1	1.37	19.4	105.1	5.1
	3.38	2.6	5.9	17.9	13.5	1.41	22.7	12.7	24.9	1.38	20.1	106.3	5.3
	4.50	4.2	9.6	18.3	13.7	1.37	23.0	13.4	25.2	1.39	20.5	106.8	5.3
100	2.25	1.1	2.6	15.7	12.5	1.67	21.4	9.4	Operation Not Recommended				
	3.38	2.4	5.4	16.7	12.9	1.55	22.0	10.7					
	4.50	3.8	8.7	17.0	13.1	1.51	22.2	11.3					
110	2.25	1.2	2.7	14.6	12.1	1.83	20.8	8.0					
	3.38	2.5	5.7	15.4	12.4	1.70	21.3	9.1					
	4.50	3.8	8.8	15.8	12.6	1.66	21.5	9.5					
120	2.25	1.2	2.9	13.6	11.8	1.98	20.4	6.9					
	3.38	2.7	6.1	14.3	12.0	1.86	20.7	7.7					
	4.50	4.0	9.3	14.6	12.1	1.82	20.8	8.1					

Interpolation is permissible; extrapolation is not.
 All entering air conditions are 80°F DB and 67°F WB in cooling, and 70°F DB in heating.
 Table does not reflect fan or pump power corrections for AHR/ISO conditions.
 All performance is based upon the lower voltage of dual voltage rated units.
 Performance stated is at the rated power supply; performance may vary as the power supply varies from the rated.
 Operation below 40°F EWT is based upon a 15% methanol antifreeze solution.
 Operation below 60°F EWT requires optional insulated water/refrigerant circuit.
 See performance correction tables for operating conditions other than those listed above.
 See Performance Data Selection Notes for operation in the shaded areas.

Performance Data – TC H/V 024 (PSC Blower)

825 CFM Airflow

Performance capacities shown in thousands of Btuh

EWT °F	WPD			Cooling - EAT 80/67°F					Heating - EAT 70°F				
	FLOW GPM	PSI	FT	TC	SC	Power kW	HR	EER	HC	Power kW	HE	LAT	COP
20	4.50	8.5	19.6	Operation Not Recommended					15.5	1.91	9.5	92.0	2.4
	6.00	8.5	19.6						15.9	1.71	10.1	87.0	2.7
30	3.00	2.2	5.1	28.9	19.7	1.16	32.8	24.8	17.6	1.74	11.8	89.0	3.0
	4.50	4.0	9.2	29.4	19.8	1.09	33.1	26.9	18.4	1.75	12.5	90.0	3.1
	6.00	7.2	16.6	29.6	19.8	1.06	33.2	28.0	18.8	1.76	12.9	91.0	3.1
40	3.00	1.9	4.4	28.0	19.4	1.28	32.4	21.9	20.4	1.78	14.4	92.0	3.4
	4.50	3.6	8.3	28.7	19.6	1.19	32.7	24.0	21.3	1.79	15.3	93.0	3.5
	6.00	6.4	14.8	28.9	19.7	1.16	32.8	25.1	21.9	1.80	15.7	94.0	3.6
50	3.00	1.7	3.9	27.3	19.1	1.42	32.1	19.3	23.2	1.82	17.0	95.0	3.7
	4.50	3.2	7.4	27.8	19.3	1.32	32.2	21.1	24.3	1.84	18.0	96.0	3.9
	6.00	5.9	13.6	28.1	19.4	1.27	32.4	22.1	24.9	1.85	18.6	97.0	3.9
60	3.00	1.5	3.5	26.3	18.8	1.58	31.7	16.7	25.9	1.87	19.6	98.0	4.1
	4.50	3.0	6.9	26.8	18.9	1.46	31.7	18.3	27.2	1.89	20.7	100.0	4.2
	6.00	5.5	12.7	27.1	19.0	1.41	31.9	19.3	27.9	1.90	21.4	100.0	4.3
70	3.00	1.4	3.2	25.1	18.3	1.77	31.1	14.2	28.6	1.91	22.1	101.0	4.4
	4.50	2.8	6.5	25.6	18.4	1.63	31.2	15.7	29.9	1.94	23.3	103.0	4.5
	6.00	5.2	12.0	26.0	18.6	1.57	31.4	16.6	30.6	1.95	24.0	103.0	4.6
80	3.00	1.3	3.0	23.8	17.8	1.99	30.6	12.0	31.1	1.96	24.4	104.0	4.7
	4.50	2.6	6.0	24.4	17.9	1.84	30.7	13.3	32.5	1.99	25.7	105.0	4.8
	6.00	4.9	11.3	24.8	18.1	1.77	30.8	14.1	33.1	2.00	26.3	106.0	4.9
85	3.00	1.3	3.0	23.1	17.5	2.12	30.4	11.0	32.3	1.98	25.5	105.0	4.8
	4.50	2.6	6.0	23.7	17.6	1.95	30.4	12.2	33.5	2.01	26.7	107.0	4.9
	6.00	4.8	11.1	24.1	17.8	1.88	30.5	12.9	34.2	2.02	27.2	107.0	5.0
90	3.00	1.2	2.8	22.4	17.3	2.25	30.1	10.0	33.4	2.01	26.5	106.0	4.9
	4.50	2.5	5.8	23.1	17.4	2.07	30.1	11.1	34.6	2.03	27.6	108.0	5.0
	6.00	4.7	10.9	23.4	17.5	1.99	30.2	11.8	35.2	2.05	28.2	108.0	5.0
100	3.00	1.2	2.8	21.0	16.8	2.54	29.7	8.3	Operation Not Recommended				
	4.50	2.4	5.5	21.6	16.9	2.34	29.7	9.2					
	6.00	4.5	10.4	22.0	17.0	2.25	29.7	9.8					
110	3.00	1.1	2.5	19.5	16.3	2.88	29.4	6.8					
	4.50	2.3	5.3	20.1	16.3	2.66	29.2	7.6					
	6.00	4.3	9.9	20.5	16.4	2.55	29.3	8.0					
120	3.00	1.0	2.3	17.8	15.7	3.26	29.0	5.5					
	4.50	2.2	5.1	18.6	15.8	3.01	28.9	6.2					
	6.00	4.2	9.7	19.1	16.0	2.89	29.0	6.6					

Interpolation is permissible; extrapolation is not.

All entering air conditions are 80°F DB and 67°F WB in cooling, and 70°F DB in heating.

Table does not reflect fan or pump power corrections for AHR/ISO conditions.

All performance is based upon the lower voltage of dual voltage rated units.

Performance stated is at the rated power supply; performance may vary as the power supply varies from the rated.

Operation below 40°F EWT is based upon a 15% methanol antifreeze solution.

Operation below 60°F EWT requires optional insulated water/refrigerant circuit.

See performance correction tables for operating conditions other than those listed above.

See Performance Data Selection Notes for operation in the shaded areas.

Performance Data – TC H/V 024 (ECM Blower)

825 CFM Airflow

Performance capacities shown in thousands of Btuh

EWT °F	WPD			Cooling - EAT 80/67°F					Heating - EAT 70°F				
	FLOW GPM	PSI	FT	TC	SC	Power kW	HR	EER	HC	Power kW	HE	LAT	COP
20	4.50	8.5	19.6	Operation Not Recommended					15.9	1.87	9.5	92.0	2.5
	6.00	8.5	19.6						15.8	1.67	10.1	87.0	2.8
30	3.00	2.2	5.1	28.9	19.7	1.12	32.7	25.8	17.6	1.70	11.8	89.0	3.0
	4.50	4.0	9.2	29.4	19.8	1.05	33.0	28.0	18.3	1.71	12.5	90.0	3.1
	6.00	7.2	16.6	29.6	19.8	1.02	33.1	29.0	18.8	1.72	12.9	90.0	3.2
40	3.00	1.9	4.4	28.0	19.4	1.24	32.2	22.6	20.3	1.74	14.4	92.0	3.4
	4.50	3.6	8.3	28.7	19.6	1.15	32.6	24.9	21.3	1.75	15.3	93.0	3.6
	6.00	6.4	14.8	28.9	19.7	1.12	32.7	25.8	21.7	1.76	15.7	94.0	3.6
50	3.00	1.7	3.9	27.3	19.1	1.38	32.0	19.8	23.1	1.78	17.0	95.0	3.8
	4.50	3.2	7.4	27.8	19.3	1.28	32.2	21.7	24.1	1.80	18.0	96.0	3.9
	6.00	5.9	13.6	28.1	19.4	1.23	32.3	22.8	24.8	1.81	18.6	97.0	4.0
60	3.00	1.5	3.5	26.3	18.8	1.54	31.6	17.1	25.8	1.83	19.6	98.0	4.1
	4.50	3.0	6.9	26.8	18.9	1.42	31.6	18.9	27.0	1.85	20.7	99.0	4.3
	6.00	5.5	12.7	27.1	19.0	1.37	31.8	19.8	27.8	1.86	21.4	100.0	4.4
70	3.00	1.4	3.2	25.1	18.3	1.73	31.0	14.5	28.5	1.87	22.1	101.0	4.5
	4.50	2.8	6.5	25.6	18.4	1.59	31.0	16.1	29.8	1.90	23.3	102.0	4.6
	6.00	5.2	12.0	26.0	18.6	1.53	31.2	17.0	30.5	1.91	24.0	103.0	4.7
80	3.00	1.3	3.0	23.8	17.8	1.95	30.5	12.2	31.0	1.92	24.4	104.0	4.7
	4.50	2.6	6.0	24.4	17.9	1.80	30.5	13.5	32.4	1.95	25.7	105.0	4.9
	6.00	4.9	11.3	24.8	18.1	1.73	30.7	14.3	33.0	1.96	26.3	106.0	4.9
85	3.00	1.3	3.0	23.1	17.5	2.08	30.2	11.1	32.1	1.94	25.5	105.0	4.8
	4.50	2.6	6.0	23.7	17.6	1.91	30.2	12.4	33.4	1.97	26.7	107.0	5.0
	6.00	4.8	11.1	24.1	17.8	1.84	30.4	13.1	34.0	1.98	27.2	108.0	5.0
90	3.00	1.2	2.8	22.4	17.3	2.21	29.9	10.1	33.2	1.97	26.5	107.0	4.9
	4.50	2.5	5.8	23.1	17.4	2.03	30.0	11.4	34.4	1.99	27.6	108.0	5.1
	6.00	4.7	10.9	23.4	17.5	1.95	30.1	12.0	35.1	2.01	28.2	109.0	5.1
100	3.00	1.2	2.8	21.0	16.8	2.50	29.5	8.4	Operation Not Recommended				
	4.50	2.4	5.5	21.6	16.9	2.30	29.5	9.4					
	6.00	4.5	10.4	22.0	17.0	2.21	29.5	9.9					
110	3.00	1.1	2.5	19.5	16.3	2.84	29.2	6.9					
	4.50	2.3	5.3	20.1	16.3	2.62	29.0	7.7					
	6.00	4.3	9.9	20.5	16.4	2.51	29.1	8.2					
120	3.00	1.0	2.3	17.8	15.7	3.22	28.8	5.5					
	4.50	2.2	5.1	18.6	15.8	2.97	28.7	6.3					
	6.00	4.2	9.7	19.1	16.0	2.85	28.8	6.7					

Interpolation is permissible; extrapolation is not.

All entering air conditions are 80°F DB and 67°F WB in cooling, and 70°F DB in heating.

Table does not reflect fan or pump power corrections for AHR/ISO conditions.

All performance is based upon the lower voltage of dual voltage rated units.

Performance stated is at the rated power supply; performance may vary as the power supply varies from the rated.

Operation below 40°F EWT is based upon a 15% methanol antifreeze solution.

Operation below 60°F EWT requires optional insulated water/refrigerant circuit.

See performance correction tables for operating conditions other than those listed above.

See Performance Data Selection Notes for operation in the shaded areas.

Performance Data – TC H/V 030 (PSC Blower)

1,000 CFM Airflow

Performance capacities shown in thousands of Btuh

EWT °F	WPD			Cooling - EAT 80/67°F					Heating - EAT 70°F				
	FLOW GPM	PSI	FT	TC	SC	Power kW	HR	EER	HC	Power kW	HE	LAT	COP
20	5.63	5.0	11.6	Operation Not Recommended					20.0	2.31	12.6	95.0	2.5
	7.50	5.0	11.6						20.4	2.08	13.4	89.0	2.9
30	3.75	1.3	3.0	34.7	22.9	1.44	39.5	24.0	22.1	2.13	14.9	90.0	3.0
	5.63	2.3	5.3	34.9	22.8	1.36	39.5	25.7	23.0	2.15	15.7	91.0	3.1
	7.50	4.2	9.7	35.0	22.7	1.32	39.4	26.5	23.5	2.16	16.2	92.0	3.2
40	3.75	1.0	2.3	34.0	22.8	1.57	39.3	21.6	25.3	2.20	17.8	93.0	3.4
	5.63	2.0	4.6	34.5	22.9	1.48	39.5	23.3	26.4	2.23	18.8	94.0	3.5
	7.50	3.7	8.5	35.1	23.2	1.44	39.9	24.4	26.9	2.24	19.4	95.0	3.5
50	3.75	0.9	2.1	32.9	22.5	1.72	38.8	19.2	28.5	2.26	20.8	96.0	3.7
	5.63	1.8	4.2	33.7	22.8	1.61	39.1	20.9	29.8	2.29	22.0	98.0	3.8
	7.50	3.4	7.9	34.0	22.9	1.57	39.3	21.7	30.5	2.30	22.7	98.0	3.9
60	3.75	0.8	1.8	31.7	21.9	1.89	38.1	16.8	31.8	2.32	23.9	99.0	4.0
	5.63	1.7	3.9	32.4	22.2	1.77	38.4	18.3	33.3	2.34	25.3	101.0	4.2
	7.50	3.1	7.2	32.7	22.3	1.71	38.5	19.1	34.1	2.36	26.0	102.0	4.2
70	3.75	0.7	1.6	30.2	21.2	2.08	37.3	14.5	35.1	2.37	26.9	102.0	4.3
	5.63	1.5	3.5	31.2	21.7	1.95	37.8	16.0	36.7	2.40	28.5	104.0	4.5
	7.50	2.9	6.7	31.7	21.9	1.89	38.1	16.8	37.6	2.42	29.3	105.0	4.6
80	3.75	0.7	1.6	28.8	20.7	2.30	36.7	12.5	38.2	2.43	29.9	105.0	4.6
	5.63	1.4	3.2	29.6	21.0	2.16	37.0	13.7	40.0	2.47	31.5	107.0	4.7
	7.50	2.7	6.2	30.2	21.2	2.08	37.3	14.5	41.2	2.50	32.6	108.0	4.8
85	3.75	0.6	1.4	27.8	20.1	2.43	36.1	11.5	39.8	2.50	31.3	107.0	4.7
	5.63	1.4	3.2	28.8	20.6	2.27	36.5	12.7	41.5	2.50	32.9	108.0	4.8
	7.50	2.7	6.2	29.3	20.8	2.20	36.8	13.4	42.6	2.50	33.9	109.0	4.9
90	3.75	0.6	1.4	26.8	19.6	2.56	35.5	10.5	41.3	2.51	32.7	108.0	4.8
	5.63	1.4	3.2	27.9	20.1	2.39	36.1	11.7	43.0	2.56	34.3	110.0	4.9
	7.50	2.6	6.0	28.5	20.4	2.31	36.4	12.3	44.0	2.59	35.1	111.0	5.0
100	3.75	0.6	1.4	24.9	18.8	2.85	34.7	8.7	Operation Not Recommended				
	5.63	1.3	3.0	26.1	19.3	2.67	35.2	9.8					
	7.50	2.5	5.8	26.7	19.6	2.58	35.5	10.3					
110	3.75	0.5	1.2	23.5	18.2	3.19	34.4	7.4					
	5.63	1.2	2.8	24.2	18.4	2.98	34.4	8.1					
	7.50	2.4	5.5	24.8	18.7	2.88	34.6	8.6					
120	3.75	0.5	1.2	21.2	17.2	3.58	33.5	5.9					
	5.63	1.2	2.8	22.3	17.6	3.34	33.8	6.7					
	7.50	2.3	5.3	22.9	17.8	3.23	33.9	7.1					

Interpolation is permissible; extrapolation is not.

All entering air conditions are 80°F DB and 67°F WB in cooling, and 70°F DB in heating.

Table does not reflect fan or pump power corrections for AHRI/ISO conditions.

All performance is based upon the lower voltage of dual voltage rated units.

Performance stated is at the rated power supply; performance may vary as the power supply varies from the rated.

Operation below 40°F EWT is based upon a 15% methanol antifreeze solution.

Operation below 60°F EWT requires optional insulated water/refrigerant circuit.

See performance correction tables for operating conditions other than those listed above.

See Performance Data Selection Notes for operation in the shaded areas.

Performance Data – TC H/V 030 (ECM Blower)

1,000 CFM Airflow

Performance capacities shown in thousands of Btuh

EWT °F	WPD			Cooling - EAT 80/67°F					Heating - EAT 70°F				
	FLOW GPM	PSI	FT	TC	SC	Power kW	HR	EER	HC	Power kW	HE	LAT	COP
20	5.63	5.0	11.6	Operation Not Recommended					20.3	2.25	12.6	92.0	2.6
	7.50	5.0	11.6						20.3	2.02	13.4	87.0	2.9
30	3.75	1.3	3.0	34.7	22.9	1.44	39.5	24.0	22.0	2.07	14.9	89.0	3.1
	5.63	2.3	5.3	34.9	22.8	1.36	39.5	25.7	22.8	2.09	15.7	90.0	3.2
	7.50	4.2	9.7	35.0	22.7	1.32	39.4	26.5	23.4	2.10	16.2	90.0	3.3
40	3.75	1.0	2.3	34.0	22.8	1.57	39.3	21.6	25.1	2.14	17.8	92.0	3.4
	5.63	2.0	4.6	34.5	22.9	1.48	39.5	23.3	26.2	2.17	18.8	93.0	3.5
	7.50	3.7	8.5	35.1	23.2	1.44	39.9	24.4	26.8	2.18	19.4	94.0	3.6
50	3.75	0.9	2.1	32.9	22.5	1.72	38.8	19.2	28.3	2.20	20.8	95.0	3.8
	5.63	1.8	4.2	33.7	22.8	1.61	39.1	20.9	29.6	2.23	22.0	96.0	3.9
	7.50	3.4	7.9	34.0	22.9	1.57	39.3	21.7	30.3	2.24	22.7	97.0	4.0
60	3.75	0.8	1.8	31.7	21.9	1.89	38.1	16.8	31.6	2.26	23.9	98.0	4.1
	5.63	1.7	3.9	32.4	22.2	1.77	38.4	18.3	33.1	2.28	25.3	99.0	4.2
	7.50	3.1	7.2	32.7	22.3	1.71	38.5	19.1	33.9	2.30	26.0	100.0	4.3
70	3.75	0.7	1.6	30.2	21.2	2.08	37.3	14.5	34.8	2.31	26.9	101.0	4.4
	5.63	1.5	3.5	31.2	21.7	1.95	37.8	16.0	36.5	2.34	28.5	102.0	4.6
	7.50	2.9	6.7	31.7	21.9	1.89	38.1	16.8	37.4	2.36	29.3	103.0	4.6
80	3.75	0.7	1.6	28.8	20.7	2.30	36.7	12.5	38.0	2.37	29.9	104.0	4.7
	5.63	1.4	3.2	29.6	21.0	2.16	37.0	13.7	39.7	2.41	31.5	105.0	4.8
	7.50	2.7	6.2	30.2	21.2	2.08	37.3	14.5	40.9	2.44	32.6	106.0	4.9
85	3.75	0.6	1.4	27.8	20.1	2.43	36.1	11.5	39.6	2.44	31.3	105.0	4.8
	5.63	1.4	3.2	28.8	20.6	2.27	36.5	12.7	41.2	2.44	32.9	107.0	4.9
	7.50	2.7	6.2	29.3	20.8	2.20	36.8	13.4	42.2	2.44	33.9	108.0	5.1
90	3.75	0.6	1.4	26.8	19.6	2.56	35.5	10.5	41.1	2.45	32.7	107.0	4.9
	5.63	1.4	3.2	27.9	20.1	2.39	36.1	11.7	42.8	2.50	34.3	108.0	5.0
	7.50	2.6	6.0	28.5	20.4	2.31	36.4	12.3	43.7	2.53	35.1	109.0	5.1
100	3.75	0.6	1.4	24.9	18.8	2.85	34.7	8.7	Operation Not Recommended				
	5.63	1.3	3.0	26.1	19.3	2.67	35.2	9.8					
	7.50	2.5	5.8	26.7	19.6	2.58	35.5	10.3					
110	3.75	0.5	1.2	23.5	18.2	3.19	34.4	7.4					
	5.63	1.2	2.8	24.2	18.4	2.98	34.4	8.1					
	7.50	2.4	5.5	24.8	18.7	2.88	34.6	8.6					
120	3.75	0.5	1.2	21.2	17.2	3.58	33.5	5.9					
	5.63	1.2	2.8	22.3	17.6	3.34	33.8	6.7					
	7.50	2.3	5.3	22.9	17.8	3.23	33.9	7.1					

Interpolation is permissible; extrapolation is not.

All entering air conditions are 80°F DB and 67°F WB in cooling, and 70°F DB in heating.

Table does not reflect fan or pump power corrections for AHR/ISO conditions.

All performance is based upon the lower voltage of dual voltage rated units.

Performance stated is at the rated power supply; performance may vary as the power supply varies from the rated.

Operation below 40°F EWT is based upon a 15% methanol antifreeze solution.

Operation below 60°F EWT requires optional insulated water/refrigerant circuit.

See performance correction tables for operating conditions other than those listed above.

See Performance Data Selection Notes for operation in the shaded areas.

Performance Data – TC H/V 036 (PSC Blower)

1,150 CFM Airflow

Performance capacities shown in thousands of Btuh

EWT °F	WPD			Cooling - EAT 80/67°F					Heating - EAT 70°F				
	FLOW GPM	PSI	FT	TC	SC	Power kW	HR	EER	HC	Power kW	HE	LAT	COP
20	6.75	6.4	14.8	Operation Not Recommended					22.6	2.67	14.1	94.0	2.5
	9.00	6.4	14.8						23.2	2.39	15.1	89.0	2.8
30	4.50	1.8	4.2	41.5	27.4	1.74	47.4	23.8	26.2	2.51	17.7	91.0	3.1
	6.75	3.1	7.2	41.7	27.5	1.69	47.4	24.7	27.5	2.56	18.8	92.0	3.2
	9.00	5.4	12.5	41.7	27.5	1.67	47.3	25.0	28.2	2.59	19.4	93.0	3.2
40	4.50	1.6	3.7	40.8	27.2	1.87	47.1	21.8	30.8	2.68	21.7	95.0	3.4
	6.75	2.7	6.2	41.4	27.4	1.78	47.4	23.3	32.4	2.74	23.1	96.0	3.5
	9.00	4.8	11.1	41.6	27.4	1.74	47.4	23.9	33.2	2.77	23.8	97.0	3.5
50	4.50	1.4	3.2	39.5	26.7	2.06	46.5	19.2	35.4	2.84	25.7	98.0	3.7
	6.75	2.4	5.5	40.4	27.0	1.92	47.0	21.0	37.2	2.90	27.3	100.0	3.8
	9.00	4.4	10.2	40.8	27.2	1.87	47.2	21.9	38.2	2.93	28.2	101.0	3.8
60	4.50	1.3	3.0	37.6	25.9	2.29	45.4	16.4	39.8	2.99	29.7	102.0	3.9
	6.75	2.3	5.3	39.1	26.5	2.13	46.3	18.4	41.9	3.05	31.5	104.0	4.0
	9.00	4.0	9.2	39.6	26.7	2.05	46.5	19.3	43.0	3.09	32.5	105.0	4.1
70	4.50	1.2	2.8	36.0	25.5	2.56	44.7	14.0	44.1	3.12	33.5	106.0	4.2
	6.75	2.1	4.9	37.3	25.9	2.38	45.4	15.7	46.3	3.19	35.4	107.0	4.3
	9.00	3.8	8.8	37.9	26.1	2.29	45.7	16.6	47.5	3.22	36.5	108.0	4.3
80	4.50	1.1	2.5	33.8	24.7	2.88	43.7	11.8	48.2	3.24	37.1	109.0	4.4
	6.75	2.0	4.6	35.3	25.2	2.67	44.4	13.2	50.4	3.30	39.1	111.0	4.5
	9.00	3.6	8.3	35.9	25.5	2.57	44.7	14.0	51.5	3.34	40.1	111.0	4.5
85	4.50	1.0	2.3	32.8	24.4	3.05	43.3	10.8	50.0	3.29	38.8	110.0	4.5
	6.75	1.9	4.4	34.1	24.8	2.84	43.8	12.1	52.2	3.35	40.7	112.0	4.6
	9.00	3.5	8.1	34.7	25.0	2.73	44.1	12.8	53.2	3.38	41.7	113.0	4.6
90	4.50	1.0	2.3	31.8	24.0	3.23	42.8	9.8	51.9	3.34	40.4	112.0	4.5
	6.75	1.9	4.4	33.0	24.4	3.00	43.3	11.0	54.0	3.40	42.3	113.0	4.7
	9.00	3.4	7.9	33.5	24.5	2.89	43.4	11.6	55.0	3.43	43.2	114.0	4.7
100	4.50	0.9	2.1	29.5	23.1	3.62	41.9	8.2	Operation Not Recommended				
	6.75	1.8	4.2	30.7	23.5	3.37	42.2	9.1					
	9.00	3.3	7.6	31.3	23.7	3.25	42.5	9.6					
110	4.50	0.9	2.1	27.3	22.4	4.04	41.1	6.8					
	6.75	1.7	3.9	28.4	22.6	3.78	41.3	7.5					
	9.00	3.1	7.2	28.8	22.7	3.65	41.3	7.9					
120	4.50	0.9	2.1	25.1	21.4	4.49	40.4	5.6					
	6.75	1.6	3.7	26.1	21.8	4.21	40.6	6.2					
	9.00	3.0	6.9	26.5	21.8	4.08	40.5	6.5					

Interpolation is permissible; extrapolation is not.

All entering air conditions are 80°F DB and 67°F WB in cooling, and 70°F DB in heating.

Table does not reflect fan or pump power corrections for AHR/ISO conditions.

All performance is based upon the lower voltage of dual voltage rated units.

Performance stated is at the rated power supply; performance may vary as the power supply varies from the rated.

Operation below 40°F EWT is based upon a 15% methanol antifreeze solution.

Operation below 60°F EWT requires optional insulated water/refrigerant circuit.

See performance correction tables for operating conditions other than those listed above.

See Performance Data Selection Notes for operation in the shaded areas.

Performance Data – TC H/V 036 (ECM Blower)

1,150 CFM Airflow

Performance capacities shown in thousands of Btuh

EWT °F	WPD			Cooling - EAT 80/67°F					Heating - EAT 70°F				
	FLOW GPM	PSI	FT	TC	SC	Power kW	HR	EER	HC	Power kW	HE	LAT	COP
20	6.75	6.4	14.8	Operation Not Recommended					20.0	2.31	12.6	95.0	2.5
	9.00	6.4	14.8						20.4	2.08	13.4	89.0	2.9
30	4.50	1.8	4.2	41.5	27.4	1.70	47.3	24.4	26.1	2.47	17.7	89.0	3.1
	6.75	3.1	7.2	41.7	27.5	1.65	47.3	25.2	27.4	2.52	18.8	90.0	3.2
	9.00	5.4	12.5	41.7	27.5	1.63	47.3	25.5	28.1	2.55	19.4	90.0	3.2
40	4.50	1.6	3.7	40.8	27.2	1.83	47.1	22.3	30.7	2.64	21.7	92.0	3.4
	6.75	2.7	6.2	41.4	27.4	1.74	47.3	23.8	32.3	2.70	23.1	93.0	3.5
	9.00	4.8	11.1	41.6	27.4	1.70	47.4	24.4	33.1	2.73	23.8	94.0	3.6
50	4.50	1.4	3.2	39.5	26.7	2.02	46.4	19.5	35.3	2.80	25.7	95.0	3.7
	6.75	2.4	5.5	40.4	27.0	1.88	46.8	21.5	37.1	2.86	27.3	96.0	3.8
	9.00	4.4	10.2	40.8	27.2	1.83	47.1	22.3	38.1	2.89	28.2	97.0	3.9
60	4.50	1.3	3.0	37.6	25.9	2.25	45.3	16.7	39.8	2.95	29.7	98.0	3.9
	6.75	2.3	5.3	39.1	26.5	2.09	46.2	18.7	41.8	3.01	31.5	99.0	4.1
	9.00	4.0	9.2	39.6	26.7	2.01	46.5	19.7	42.9	3.05	32.5	100.0	4.1
70	4.50	1.2	2.8	36.0	25.5	2.52	44.6	14.3	44.0	3.08	33.5	101.0	4.2
	6.75	2.1	4.9	37.3	25.9	2.34	45.3	15.9	46.2	3.15	35.4	102.0	4.3
	9.00	3.8	8.8	37.9	26.1	2.25	45.6	16.8	47.4	3.18	36.5	103.0	4.4
80	4.50	1.1	2.5	33.8	24.7	2.84	43.5	11.9	48.0	3.20	37.1	104.0	4.4
	6.75	2.0	4.6	35.3	25.2	2.63	44.3	13.4	50.2	3.26	39.1	105.0	4.5
	9.00	3.6	8.3	35.9	25.5	2.53	44.5	14.2	51.4	3.30	40.1	106.0	4.6
85	4.50	1.0	2.3	32.8	24.4	3.01	43.1	10.9	49.9	3.25	38.8	105.0	4.5
	6.75	1.9	4.4	34.1	24.8	2.80	43.7	12.2	52.0	3.31	40.7	107.0	4.6
	9.00	3.5	8.1	34.7	25.0	2.69	43.9	12.9	53.1	3.34	41.7	108.0	4.7
90	4.50	1.0	2.3	31.8	24.0	3.19	42.7	10.0	51.7	3.30	40.4	107.0	4.6
	6.75	1.9	4.4	33.0	24.4	2.96	43.1	11.1	53.8	3.36	42.3	108.0	4.7
	9.00	3.4	7.9	33.5	24.5	2.85	43.2	11.7	54.8	3.39	43.2	109.0	4.7
100	4.50	0.9	2.1	29.5	23.1	3.58	41.7	8.2	Operation Not Recommended				
	6.75	1.8	4.2	30.7	23.5	3.33	42.1	9.2					
	9.00	3.3	7.6	31.3	23.7	3.21	42.3	9.7					
110	4.50	0.9	2.1	27.3	22.4	4.00	41.0	6.8					
	6.75	1.7	3.9	28.4	22.6	3.74	41.2	7.6					
	9.00	3.1	7.2	28.8	22.7	3.61	41.1	8.0					
120	4.50	0.9	2.1	25.1	21.4	4.45	40.3	5.6					
	6.75	1.6	3.7	26.1	21.8	4.17	40.3	6.3					
	9.00	3.0	6.9	26.5	21.8	4.04	40.3	6.6					

Interpolation is permissible; extrapolation is not.

All entering air conditions are 80°F DB and 67°F WB in cooling, and 70°F DB in heating.

Table does not reflect fan or pump power corrections for AHR/ISO conditions.

All performance is based upon the lower voltage of dual voltage rated units.

Performance stated is at the rated power supply; performance may vary as the power supply varies from the rated.

Operation below 40°F EWT is based upon a 15% methanol antifreeze solution.

Operation below 60°F EWT requires optional insulated water/refrigerant circuit.

See performance correction tables for operating conditions other than those listed above.

See Performance Data Selection Notes for operation in the shaded areas.

Performance Data – TCV 041 (PSC Blower)

1,125 CFM Airflow

Performance capacities shown in thousands of Btuh

EWT °F	WPD			Cooling - EAT 80/67°F					Heating - EAT 70°F				
	FLOW GPM	PSI	FT	TC	SC	Power kW	HR	EER	HC	Power kW	HE	LAT	COP
20	10.00	8.8	20.3	Operation Not Recommended					27.2	2.85	17.6	92.4	2.8
30	5.00	2.2	5.0	46.8	28.5	1.71	52.6	27.4	29.5	2.90	19.7	94.3	3.0
	7.50	4.6	10.7	47.6	28.6	1.57	52.9	30.4	30.7	2.93	20.7	95.2	3.1
	10.00	7.7	17.9	48.0	28.6	1.50	53.0	32.1	31.3	2.94	21.3	95.7	3.1
40	5.00	1.9	4.3	45.6	28.1	1.89	52.0	24.2	33.2	2.99	23.1	97.4	3.3
	7.50	4.0	9.3	46.1	28.3	1.82	52.3	25.3	34.6	3.02	24.3	98.5	3.4
	10.00	6.9	19.9	46.5	28.4	1.77	52.4	26.2	35.3	3.04	25.0	99.1	3.4
50	5.00	1.6	3.6	44.2	27.6	2.07	51.2	21.3	37.0	3.08	26.5	100.4	3.5
	7.50	3.5	8.0	45.3	28.0	1.93	51.8	23.4	38.5	3.12	27.9	101.7	3.6
	10.00	6.1	14.2	45.8	28.2	1.86	52.1	24.6	39.4	3.14	28.7	102.4	3.7
60	5.00	1.3	3.0	42.6	27.0	2.27	50.3	18.8	40.7	3.17	29.9	103.5	3.8
	7.50	3.0	7.0	43.8	27.4	2.12	51.0	20.6	42.5	3.22	31.5	104.9	3.9
	10.00	5.5	12.8	44.4	27.7	2.05	51.3	21.7	43.4	3.24	32.4	105.7	3.9
70	5.00	1.1	2.6	40.8	26.2	2.49	49.3	16.4	44.4	3.27	33.3	106.6	4.0
	7.50	2.6	6.1	42.1	26.8	2.33	50.0	18.1	46.4	3.32	35.1	108.2	4.1
	10.00	5.1	11.7	42.8	27.0	2.25	50.4	19.0	47.4	3.35	36.0	109.0	4.2
80	5.00	0.9	2.2	38.9	25.4	2.74	48.3	14.2	48.1	3.37	36.7	109.6	4.2
	7.50	2.3	5.4	40.3	26.0	2.56	49.0	15.8	50.3	3.43	38.6	111.4	4.3
	10.00	4.7	11.0	41.0	26.3	2.47	49.4	16.6	51.4	3.46	39.6	112.3	4.4
85	5.00	0.9	2.0	37.9	25.0	2.88	47.8	13.2	50.0	3.40	38.3	111.1	4.3
	7.50	2.2	5.1	39.3	25.6	2.69	48.5	14.7	52.2	3.50	40.3	113.0	4.4
	10.00	4.6	10.7	40.0	25.9	2.60	48.9	15.5	53.4	3.50	41.4	114.0	4.4
90	5.00	0.8	1.9	36.9	24.6	3.03	47.3	12.2	51.8	3.47	40.0	112.7	4.4
	7.50	2.1	4.4	38.3	25.2	2.82	48.0	13.6	54.1	3.54	42.0	114.6	4.5
	10.00	4.6	10.6	39.0	25.5	2.72	48.3	14.3	55.4	3.58	43.2	115.6	4.5
100	5.00	0.7	1.7	32.7	23.0	3.76	45.5	8.7	Operation Not Recommended				
	7.50	2.0	4.5	34.1	23.6	3.49	46.1	9.8					
	10.00	4.5	10.5	34.9	23.8	3.36	46.4	10.4					
110	5.00	0.7	1.5	30.5	22.3	4.22	44.9	7.2					
	7.50	1.9	4.4	31.9	22.8	3.91	45.3	8.2					
	10.00	4.6	10.7	32.7	23.0	3.76	45.5	8.7					
120	5.00	0.7	1.5	28.7	21.7	4.63	44.6	6.2					
	7.50	1.9	4.4	30.2	22.2	4.28	44.9	7.1					
	10.00	4.8	11.2	30.9	22.4	4.12	45.0	7.5					

Interpolation is permissible; extrapolation is not.
 All entering air conditions are 80°F DB and 67°F WB in cooling, and 70°F DB in heating.
 Table does not reflect fan or pump power corrections for AHRI/ISO conditions.
 All performance is based upon the lower voltage of dual voltage rated units.
 Performance stated is at the rated power supply; performance may vary as the power supply varies from the rated.
 Operation below 40°F EWT is based upon a 15% methanol antifreeze solution.
 Operation below 60°F EWT requires optional insulated water/refrigerant circuit.
 See performance correction tables for operating conditions other than those listed above.
 See Performance Data Selection Notes for operation in the shaded areas.

Performance Data – TC H/V 042 (PSC Blower)

1,400 CFM Airflow

Performance capacities shown in thousands of Btuh

EWT °F	WPD			Cooling - EAT 80/67°F					Heating - EAT 70°F				
	FLOW GPM	PSI	FT	TC	SC	Power kW	HR	EER	HC	Power kW	HE	LAT	COP
20	7.88	9.2	21.3	Operation Not Recommended					28.8	3.37	18.1	95.0	2.5
	10.50	9.2	21.3						29.5	3.03	19.3	90.0	2.9
30	5.25	2.3	5.3	49.3	34.7	1.95	55.9	25.4	32.4	3.10	21.9	91.0	3.1
	7.88	4.3	9.9	50.4	35.2	1.83	56.6	27.5	33.7	3.14	23.1	92.0	3.2
	10.50	7.9	18.2	50.9	35.5	1.78	57.0	28.6	34.5	3.16	23.8	93.0	3.2
40	5.25	2.0	4.6	47.8	33.9	2.13	55.0	22.4	37.0	3.23	26.1	94.0	3.4
	7.88	3.9	9.0	48.9	34.4	2.00	55.6	24.5	38.7	3.27	27.6	96.0	3.5
	10.50	7.1	16.4	49.4	34.7	1.94	56.0	25.5	39.6	3.30	28.4	96.0	3.5
50	5.25	1.8	4.2	46.2	33.1	2.35	54.2	19.6	41.8	3.36	30.4	98.0	3.7
	7.88	3.5	8.1	47.3	33.6	2.20	54.8	21.5	43.8	3.41	32.2	99.0	3.8
	10.50	6.5	15.0	47.9	33.9	2.12	55.1	22.5	44.9	3.44	33.2	100.0	3.8
60	5.25	1.6	3.7	44.9	32.6	2.61	53.8	17.2	46.7	3.49	34.8	101.0	3.9
	7.88	3.3	7.6	45.7	32.8	2.43	53.9	18.8	49.0	3.56	36.9	102.0	4.0
	10.50	6.1	14.1	46.2	33.1	2.35	54.2	19.7	50.2	3.59	38.0	103.0	4.1
70	5.25	1.5	3.5	43.0	31.8	2.91	52.9	14.8	51.5	3.63	39.2	104.0	4.2
	7.88	3.1	7.2	43.9	32.0	2.71	53.1	16.2	54.1	3.70	41.5	106.0	4.3
	10.50	5.7	13.2	44.5	32.3	2.61	53.4	17.1	55.4	3.73	42.7	107.0	4.4
80	5.25	1.4	3.2	41.1	31.0	3.26	52.2	12.6	56.3	3.76	43.4	107.0	4.4
	7.88	2.9	6.7	42.1	31.3	3.03	52.4	13.9	59.0	3.83	45.9	109.0	4.5
	10.50	5.4	12.5	42.7	31.5	2.92	52.6	14.6	60.4	3.87	47.2	110.0	4.6
85	5.25	1.3	3.0	40.0	30.7	3.46	51.8	11.6	58.6	3.82	45.5	109.0	4.5
	7.88	2.8	6.5	41.1	30.9	3.21	52.0	12.9	61.3	3.89	48.0	111.0	4.6
	10.50	5.3	12.2	41.7	31.2	3.09	52.3	13.6	62.7	3.93	49.3	111.0	4.7
90	5.25	1.3	3.0	39.0	30.3	3.65	51.5	10.7	60.8	3.88	47.6	110.0	4.6
	7.88	2.8	6.5	40.1	30.6	3.39	51.6	11.8	63.6	3.96	50.1	112.0	4.7
	10.50	5.2	12.0	40.7	30.8	3.27	51.9	12.5	65.1	3.99	51.4	113.0	4.8
100	5.25	1.2	2.8	36.7	29.6	4.10	50.7	8.9	Operation Not Recommended				
	7.88	2.7	6.2	37.9	29.9	3.81	50.9	9.9					
	10.50	5.0	11.6	38.6	30.1	3.67	51.1	10.5					
110	5.25	1.2	2.8	34.2	28.9	4.60	49.9	7.4					
	7.88	2.6	6.0	35.5	29.1	4.28	50.1	8.3					
	10.50	4.8	11.1	36.2	29.4	4.12	50.4	8.8					
120	5.25	1.1	2.5	31.4	28.0	5.15	49.1	6.1					
	7.88	2.5	5.8	32.8	28.3	4.80	49.3	6.8					
	10.50	4.7	10.9	33.7	28.6	4.63	49.5	7.3					

Interpolation is permissible; extrapolation is not.

All entering air conditions are 80°F DB and 67°F WB in cooling, and 70°F DB in heating.

Table does not reflect fan or pump power corrections for AHR/ISO conditions.

All performance is based upon the lower voltage of dual voltage rated units.

Performance stated is at the rated power supply; performance may vary as the power supply varies from the rated.

Operation below 40°F EWT is based upon a 15% methanol antifreeze solution.

Operation below 60°F EWT requires optional insulated water/refrigerant circuit.

See performance correction tables for operating conditions other than those listed above.

See Performance Data Selection Notes for operation in the shaded areas.

Performance Data – TC H/V 042 (ECM Blower)

1,400 CFM Airflow

Performance capacities shown in thousands of Btuh

EWT °F	WPD			Cooling - EAT 80/67°F					Heating - EAT 70°F				
	FLOW GPM	PSI	FT	TC	SC	Power kW	HR	EER	HC	Power kW	HE	LAT	COP
20	7.88	9.2	21.3	Operation Not Recommended					Operation Not Recommended				
	10.50	9.2	21.3										
30	5.25	2.3	5.3	49.3	34.7	1.79	55.4	27.5	31.9	2.94	21.9	89.0	3.2
	7.88	4.3	9.9	50.4	35.2	1.67	56.1	30.2	33.3	2.98	23.1	90.0	3.3
	10.50	7.9	18.2	50.9	35.5	1.62	56.4	31.4	34.0	3.00	23.8	90.0	3.3
40	5.25	2.0	4.6	47.8	33.9	1.97	54.5	24.3	36.6	3.07	26.1	92.0	3.5
	7.88	3.9	9.0	48.9	34.4	1.84	55.2	26.6	38.2	3.11	27.6	93.0	3.6
	10.50	7.1	16.4	49.4	34.7	1.78	55.5	27.8	39.1	3.14	28.4	94.0	3.7
50	5.25	1.8	4.2	46.2	33.1	2.19	53.7	21.1	41.3	3.20	30.4	95.0	3.8
	7.88	3.5	8.1	47.3	33.6	2.04	54.3	23.2	43.3	3.25	32.2	96.0	3.9
	10.50	6.5	15.0	47.9	33.9	1.96	54.6	24.4	44.4	3.28	33.2	97.0	4.0
60	5.25	1.6	3.7	44.9	32.6	2.45	53.3	18.3	46.2	3.33	34.8	98.0	4.1
	7.88	3.3	7.6	45.7	32.8	2.27	53.4	20.1	48.5	3.40	36.9	99.0	4.2
	10.50	6.1	14.1	46.2	33.1	2.19	53.7	21.1	49.7	3.43	38.0	100.0	4.2
70	5.25	1.5	3.5	43.0	31.8	2.75	52.4	15.6	51.0	3.47	39.2	101.0	4.3
	7.88	3.1	7.2	43.9	32.0	2.55	52.6	17.2	53.6	3.54	41.5	102.0	4.4
	10.50	5.7	13.2	44.5	32.3	2.45	52.9	18.2	54.9	3.57	42.7	103.0	4.5
80	5.25	1.4	3.2	41.1	31.0	3.10	51.7	13.3	55.7	3.60	43.4	104.0	4.5
	7.88	2.9	6.7	42.1	31.3	2.87	51.9	14.7	58.4	3.67	45.9	105.0	4.7
	10.50	5.4	12.5	42.7	31.5	2.76	52.1	15.5	59.9	3.71	47.2	106.0	4.7
85	5.25	1.3	3.0	40.0	30.7	3.30	51.3	12.1	58.0	3.66	45.5	105.0	4.6
	7.88	2.8	6.5	41.1	30.9	3.05	51.5	13.5	60.7	3.73	48.0	107.0	4.8
	10.50	5.3	12.2	41.7	31.2	2.93	51.7	14.2	62.2	3.77	49.3	108.0	4.8
90	5.25	1.3	3.0	39.0	30.3	3.49	50.9	11.2	60.3	3.72	47.6	107.0	4.8
	7.88	2.8	6.5	40.1	30.6	3.23	51.1	12.4	63.1	3.80	50.1	108.0	4.9
	10.50	5.2	12.0	40.7	30.8	3.11	51.3	13.1	64.5	3.83	51.4	109.0	4.9
100	5.25	1.2	2.8	36.7	29.6	3.94	50.1	9.3	Operation Not Recommended				
	7.88	2.7	6.2	37.9	29.9	3.65	50.4	10.4					
	10.50	5.0	11.6	38.6	30.1	3.51	50.6	11.0					
110	5.25	1.2	2.8	34.2	28.9	4.44	49.4	7.7					
	7.88	2.6	6.0	35.5	29.1	4.12	49.6	8.6					
	10.50	4.8	11.1	36.2	29.4	3.96	49.7	9.1					
120	5.25	1.1	2.5	31.4	28.0	4.99	48.4	6.3					
	7.88	2.5	5.8	32.8	28.3	4.64	48.6	7.1					
	10.50	4.7	10.9	33.7	28.6	4.47	49.0	7.5					

Interpolation is permissible; extrapolation is not.

All entering air conditions are 80°F DB and 67°F WB in cooling, and 70°F DB in heating.

Table does not reflect fan or pump power corrections for AHR/ISO conditions.

All performance is based upon the lower voltage of dual voltage rated units.

Performance stated is at the rated power supply; performance may vary as the power supply varies from the rated.

Operation below 40°F EWT is based upon a 15% methanol antifreeze solution.

Operation below 60°F EWT requires optional insulated water/refrigerant circuit.

See performance correction tables for operating conditions other than those listed above.

See Performance Data Selection Notes for operation in the shaded areas.

Performance Data – TC H/V 048 (PSC Blower)

1,550 CFM Airflow

Performance capacities shown in thousands of Btuh

EWT °F	WPD			Cooling - EAT 80/67°F					Heating - EAT 70°F				
	FLOW GPM	PSI	FT	TC	SC	Power kW	HR	EER	HC	Power kW	HE	LAT	COP
20	9.00	6.8	15.7	Operation Not Recommended					30.9	3.54	19.6	94.0	2.6
	12.00	6.8	15.7						31.6	3.18	20.9	88.0	2.9
30	6.00	1.8	4.2	58.8	39.0	2.34	66.7	25.1	34.7	3.24	23.8	90.0	3.1
	9.00	3.4	7.9	59.8	39.1	2.20	67.2	27.2	35.3	3.26	24.2	90.0	3.2
	12.00	6.2	14.3	60.3	39.1	2.14	67.5	28.2	36.0	3.27	24.9	91.0	3.2
40	6.00	1.6	3.7	57.1	38.5	2.57	65.8	22.2	38.8	3.33	27.5	92.0	3.4
	9.00	3.1	7.2	58.3	38.9	2.40	66.4	24.3	40.5	3.36	29.1	93.0	3.5
	12.00	5.8	13.4	58.9	39.0	2.32	66.8	25.4	41.7	3.37	30.2	94.0	3.6
50	6.00	1.5	3.5	55.1	37.7	2.83	64.7	19.4	44.7	3.42	33.0	96.0	3.8
	9.00	3.0	6.9	56.5	38.3	2.64	65.5	21.4	46.0	3.46	34.3	97.0	3.9
	12.00	5.5	12.7	57.2	38.5	2.55	65.8	22.5	47.1	3.48	35.3	97.0	4.0
60	6.00	1.4	3.2	52.8	36.8	3.15	63.5	16.8	49.3	3.51	37.4	99.0	4.1
	9.00	2.8	6.5	54.5	37.5	2.92	64.4	18.6	51.8	3.56	39.6	100.0	4.3
	12.00	5.3	12.2	55.2	37.8	2.81	64.8	19.6	53.1	3.58	40.9	101.0	4.3
70	6.00	1.3	3.0	50.3	35.7	3.52	62.3	14.3	54.8	3.61	42.4	102.0	4.4
	9.00	2.7	6.2	52.1	36.4	3.25	63.2	16.0	57.5	3.67	45.0	103.0	4.6
	12.00	5.1	11.8	53.0	36.8	3.13	63.6	16.9	59.0	3.70	46.4	104.0	4.7
80	6.00	1.3	3.0	47.6	34.5	3.94	61.0	12.1	60.2	3.72	47.5	105.0	4.7
	9.00	2.6	6.0	49.5	35.3	3.64	61.9	13.6	63.2	3.78	50.2	107.0	4.9
	12.00	4.9	11.3	50.4	35.7	3.50	62.4	14.4	64.8	3.82	51.7	107.0	5.0
85	6.00	1.2	2.8	46.1	33.8	4.19	60.4	11.1	62.8	3.78	49.9	106.0	4.9
	9.00	2.6	6.0	48.1	34.7	3.87	61.3	12.5	65.9	3.84	52.7	108.0	5.0
	12.00	4.9	11.3	49.0	35.1	3.72	61.7	13.2	67.5	3.88	54.1	109.0	5.1
90	6.00	1.2	2.8	44.6	33.2	4.43	59.8	10.1	65.5	3.83	52.3	108.0	5.0
	9.00	2.6	6.0	46.6	34.1	4.10	60.6	11.4	68.6	3.91	55.1	110.0	5.1
	12.00	4.8	11.1	47.6	34.5	3.94	61.1	12.1	70.2	3.95	56.6	111.0	5.2
100	6.00	1.2	2.8	41.4	31.9	4.99	58.5	8.3	Operation Not Recommended				
	9.00	2.5	5.8	43.5	32.7	4.62	59.3	9.4					
	12.00	4.7	10.9	44.6	33.2	4.44	59.7	10.0					
110	6.00	1.1	2.5	38.0	30.4	5.62	57.3	6.8					
	9.00	2.4	5.5	40.2	31.4	5.21	58.0	7.7					
	12.00	4.6	10.6	41.3	31.8	5.01	58.5	8.2					
120	6.00	1.1	2.5	34.4	28.9	6.34	56.1	5.4					
	9.00	2.4	5.5	36.7	29.9	5.88	56.8	6.2					
	12.00	4.5	10.4	37.8	30.3	5.66	57.2	6.7					

Interpolation is permissible; extrapolation is not.

All entering air conditions are 80°F DB and 67°F WB in cooling, and 70°F DB in heating.

Table does not reflect fan or pump power corrections for AHR/ISO conditions.

All performance is based upon the lower voltage of dual voltage rated units.

Performance stated is at the rated power supply; performance may vary as the power supply varies from the rated.

Operation below 40°F EWT is based upon a 15% methanol antifreeze solution.

Operation below 60°F EWT requires optional insulated water/refrigerant circuit.

See performance correction tables for operating conditions other than those listed above.

See Performance Data Selection Notes for operation in the shaded areas.

Performance Data – TC H/V 048 (ECM Blower)

1,550 CFM Airflow

Performance capacities shown in thousands of Btuh

EWT °F	WPD			Cooling - EAT 80/67°F					Heating - EAT 70°F				
	FLOW GPM	PSI	FT	TC	SC	Power kW	HR	EER	HC	Power kW	HE	LAT	COP
20	9.00	6.8	15.7	Operation Not Recommended					31.4	3.45	19.6	92.0	2.7
	12.00	6.8	15.7						31.5	3.09	20.9	87.0	3.0
30	6.00	1.8	4.2	58.8	39.0	2.25	66.5	26.1	34.6	3.15	23.8	89.0	3.2
	9.00	3.4	7.9	59.8	39.1	2.11	67.0	28.3	35.0	3.17	24.2	90.0	3.2
	12.00	6.2	14.3	60.3	39.1	2.05	67.3	29.4	35.8	3.18	24.9	90.0	3.3
40	6.00	1.6	3.7	57.1	38.5	2.48	65.6	23.0	38.6	3.24	27.5	92.0	3.5
	9.00	3.1	7.2	58.3	38.9	2.31	66.2	25.2	40.3	3.27	29.1	93.0	3.6
	12.00	5.8	13.4	58.9	39.0	2.23	66.5	26.4	41.4	3.28	30.2	94.0	3.7
50	6.00	1.5	3.5	55.1	37.7	2.74	64.5	20.1	44.4	3.33	33.0	95.0	3.9
	9.00	3.0	6.9	56.5	38.3	2.55	65.2	22.1	45.8	3.37	34.3	96.0	4.0
	12.00	5.5	12.7	57.2	38.5	2.46	65.6	23.2	46.9	3.39	35.3	97.0	4.0
60	6.00	1.4	3.2	52.8	36.8	3.06	63.3	17.2	49.1	3.42	37.4	98.0	4.2
	9.00	2.8	6.5	54.5	37.5	2.83	64.2	19.2	51.5	3.47	39.6	99.0	4.3
	12.00	5.3	12.2	55.2	37.8	2.72	64.5	20.3	52.8	3.49	40.9	100.0	4.4
70	6.00	1.3	3.0	50.3	35.7	3.43	62.0	14.6	54.4	3.52	42.4	101.0	4.5
	9.00	2.7	6.2	52.1	36.4	3.16	62.9	16.5	57.2	3.58	45.0	102.0	4.7
	12.00	5.1	11.8	53.0	36.8	3.04	63.4	17.4	58.7	3.61	46.4	103.0	4.8
80	6.00	1.3	3.0	47.6	34.5	3.85	60.8	12.3	59.9	3.63	47.5	104.0	4.8
	9.00	2.6	6.0	49.5	35.3	3.55	61.6	13.9	62.8	3.69	50.2	105.0	5.0
	12.00	4.9	11.3	50.4	35.7	3.41	62.1	14.8	64.4	3.73	51.7	106.0	5.1
85	6.00	1.2	2.8	46.1	33.8	4.10	60.1	11.2	62.5	3.69	49.9	105.0	5.0
	9.00	2.6	6.0	48.1	34.7	3.78	61.0	12.7	65.5	3.75	52.7	107.0	5.1
	12.00	4.9	11.3	49.0	35.1	3.63	61.4	13.5	67.0	3.79	54.1	108.0	5.2
90	6.00	1.2	2.8	44.6	33.2	4.34	59.4	10.3	65.1	3.74	52.3	107.0	5.1
	9.00	2.6	6.0	46.6	34.1	4.01	60.3	11.6	68.1	3.82	55.1	108.0	5.2
	12.00	4.8	11.1	47.6	34.5	3.85	60.8	12.3	69.8	3.86	56.6	109.0	5.3
100	6.00	1.2	2.8	41.4	31.9	4.90	58.1	8.4	Operation Not Recommended				
	9.00	2.5	5.8	43.5	32.7	4.53	59.0	9.6					
	12.00	4.7	10.9	44.6	33.2	4.35	59.5	10.2					
110	6.00	1.1	2.5	38.0	30.4	5.53	56.9	6.9					
	9.00	2.4	5.5	40.2	31.4	5.12	57.7	7.8					
	12.00	4.6	10.6	41.3	31.8	4.92	58.1	8.4					
120	6.00	1.1	2.5	34.4	28.9	6.25	55.7	5.5					
	9.00	2.4	5.5	36.7	29.9	5.79	56.5	6.3					
	12.00	4.5	10.4	37.8	30.3	5.57	56.8	6.8					

Interpolation is permissible; extrapolation is not.

All entering air conditions are 80°F DB and 67°F WB in cooling, and 70°F DB in heating.

Table does not reflect fan or pump power corrections for AHR/ISO conditions.

All performance is based upon the lower voltage of dual voltage rated units.

Performance stated is at the rated power supply; performance may vary as the power supply varies from the rated.

Operation below 40°F EWT is based upon a 15% methanol antifreeze solution.

Operation below 60°F EWT requires optional insulated water/refrigerant circuit.

See performance correction tables for operating conditions other than those listed above.

See Performance Data Selection Notes for operation in the shaded areas.

Performance Data – TC H/V 060 (PSC Blower)

1,950 CFM Airflow

Performance capacities shown in thousands of Btuh

EWT °F	WPD			Cooling - EAT 80/67°F					Heating - EAT 70°F				
	FLOW GPM	PSI	FT	TC	SC	Power kW	HR	EER	HC	Power kW	HE	LAT	COP
20	15.00	14.0	32.3	Operation Not Recommended					42.6	4.48	27.5	90.0	2.8
30	7.50	3.4	7.9	71.0	47.0	3.12	81.6	22.8	46.6	4.56	31.1	92.0	3.0
	11.25	6.8	15.7	71.8	47.0	2.99	82.0	24.0	48.6	4.61	33.0	93.0	3.1
	15.00	12.6	29.1	72.1	46.8	2.94	82.1	24.6	49.7	4.64	34.0	94.0	3.1
40	7.50	3.1	7.2	69.3	46.5	3.34	80.6	20.8	53.5	4.73	37.5	95.0	3.3
	11.25	6.3	14.6	70.6	47.0	3.18	81.3	22.2	56.1	4.80	39.8	97.0	3.4
	15.00	11.8	27.3	71.1	47.0	3.10	81.6	22.9	57.5	4.83	41.1	97.0	3.5
50	7.50	2.8	6.5	67.3	45.6	3.61	79.6	18.7	60.9	4.92	44.2	99.0	3.6
	11.25	5.9	13.6	68.7	46.3	3.41	80.3	20.1	64.1	5.01	47.1	100.0	3.8
	15.00	11.1	25.6	69.4	46.6	3.32	80.7	20.9	65.9	5.05	48.7	101.0	3.8
60	7.50	2.6	6.0	65.0	44.5	3.93	78.4	16.5	68.5	5.12	51.0	103.0	3.9
	11.25	5.6	12.9	66.3	45.1	3.70	78.9	17.9	72.1	5.22	54.4	104.0	4.1
	15.00	10.7	24.7	66.8	45.3	3.59	79.0	18.6	74.1	5.28	56.2	105.0	4.1
70	7.50	2.4	5.5	62.0	43.0	4.32	76.7	14.3	75.9	5.33	57.8	106.0	4.2
	11.25	5.4	12.5	63.6	43.7	4.05	77.4	15.7	79.9	5.44	61.4	108.0	4.3
	15.00	10.3	23.8	64.2	43.9	3.92	77.5	16.3	82.0	5.50	63.2	109.0	4.4
80	7.50	2.3	5.3	58.8	41.5	4.78	75.1	12.3	83.0	5.52	64.2	109.0	4.4
	11.25	5.2	12.0	60.4	42.2	4.47	75.7	13.5	87.0	5.63	67.7	111.0	4.5
	15.00	9.9	22.9	61.1	42.4	4.32	75.8	14.1	89.0	5.69	69.5	112.0	4.6
85	7.50	2.3	5.3	57.0	40.8	5.04	74.2	11.4	86.2	5.60	67.0	111.0	4.5
	11.25	5.1	11.8	58.7	41.4	4.71	74.8	12.5	89.9	5.70	70.4	113.0	4.6
	15.00	9.8	22.6	59.5	41.6	4.55	75.0	13.1	91.8	5.80	72.0	114.0	4.7
90	7.50	2.2	5.1	55.3	40.1	5.30	73.4	10.4	89.3	5.70	69.9	112.0	4.6
	11.25	5.0	11.6	57.1	40.7	4.95	74.0	11.5	92.9	5.80	73.1	114.0	4.7
	15.00	9.6	22.2	57.8	40.9	4.78	74.1	12.1	94.5	5.84	74.5	115.0	4.7
100	7.50	2.1	4.9	51.7	38.9	5.90	71.9	8.8	Operation Not Recommended				
	11.25	4.9	11.3	53.5	39.3	5.51	72.3	9.7					
	15.00	9.4	21.7	54.2	39.4	5.32	72.4	10.2					
110	7.50	2.0	4.6	48.5	38.2	6.59	71.0	7.4					
	11.25	4.8	11.1	49.8	38.1	6.15	70.8	8.1					
	15.00	9.2	21.3	50.6	38.2	5.94	71.0	8.5					
120	7.50	2.0	4.6	44.7	37.5	7.36	70.0	6.1					
	11.25	4.7	10.9	46.0	37.1	6.88	69.6	6.7					
	15.00	9.0	20.8	46.8	37.0	6.64	69.5	7.0					

Interpolation is permissible; extrapolation is not.

All entering air conditions are 80°F DB and 67°F WB in cooling, and 70°F DB in heating.

Table does not reflect fan or pump power corrections for AHR/ISO conditions.

All performance is based upon the lower voltage of dual voltage rated units.

Performance stated is at the rated power supply; performance may vary as the power supply varies from the rated.

Operation below 40°F EWT is based upon a 15% methanol antifreeze solution.

Operation below 60°F EWT requires optional insulated water/refrigerant circuit.

See performance correction tables for operating conditions other than those listed above.

See Performance Data Selection Notes for operation in the shaded areas.

Performance Data – TC H/V 060 (ECM Blower)

1,950 CFM Airflow

Performance capacities shown in thousands of Btuh

EWT °F	WPD			Cooling - EAT 80/67°F					Heating - EAT 70°F				
	FLOW GPM	PSI	FT	TC	SC	Power kW	HR	EER	HC	Power kW	HE	LAT	COP
20	15.00	14.0	32.3	Operation Not Recommended					42.0	4.2	27.5	87.0	2.9
30	7.50	3.4	7.9	71.0	47.0	2.9	80.8	24.7	45.8	4.3	31.1	89.0	3.1
	11.25	6.8	15.7	71.8	47.0	2.7	81.2	26.2	47.9	4.4	33.0	90.0	3.2
	15.00	12.6	29.1	72.1	46.8	2.7	81.3	26.7	49.0	4.4	34.0	90.0	3.3
40	7.50	3.1	7.2	69.3	46.5	3.1	79.9	22.4	52.8	4.5	37.5	92.0	3.5
	11.25	6.3	14.6	70.6	47.0	2.9	80.6	24.1	55.3	4.6	39.8	93.0	3.6
	15.00	11.8	27.3	71.1	47.0	2.9	80.8	24.9	56.7	4.6	41.1	94.0	3.6
50	7.50	2.8	6.5	67.3	45.6	3.4	78.8	20.0	60.2	4.7	44.2	95.0	3.8
	11.25	5.9	13.6	68.7	46.3	3.2	79.5	21.7	63.4	4.8	47.1	96.0	3.9
	15.00	11.1	25.6	69.4	46.6	3.1	79.9	22.6	65.1	4.8	48.7	97.0	4.0
60	7.50	2.6	6.0	65.0	44.5	3.7	77.6	17.6	67.6	4.9	51.0	98.0	4.1
	11.25	5.6	12.9	66.3	45.1	3.5	78.1	19.2	71.4	5.0	54.4	99.0	4.2
	15.00	10.7	24.7	66.8	45.3	3.3	78.2	20.0	73.4	5.0	56.2	100.0	4.3
70	7.50	2.4	5.5	62.0	43.0	4.1	75.9	15.2	75.2	5.1	57.8	101.0	4.3
	11.25	5.4	12.5	63.6	43.7	3.8	76.6	16.7	79.1	5.2	61.4	102.0	4.5
	15.00	10.3	23.8	64.2	43.9	3.7	76.7	17.5	81.1	5.3	63.2	103.0	4.5
80	7.50	2.3	5.3	58.8	41.5	4.5	74.3	13.0	82.2	5.3	64.2	104.0	4.6
	11.25	5.2	12.0	60.4	42.2	4.2	74.8	14.3	86.1	5.4	67.7	105.0	4.7
	15.00	9.9	22.9	61.1	42.4	4.1	75.0	15.0	88.1	5.4	69.5	106.0	4.7
85	7.50	2.3	5.3	57.0	40.8	4.8	73.4	11.9	85.3	5.4	67.0	105.0	4.7
	11.25	5.1	11.8	58.7	41.4	4.5	73.9	13.1	89.0	5.5	70.4	107.0	4.8
	15.00	9.8	22.6	59.5	41.6	4.3	74.2	13.8	91.0	5.6	72.0	108.0	4.8
90	7.50	2.2	5.1	55.3	40.1	5.1	72.5	10.9	88.5	5.5	69.9	107.0	4.8
	11.25	5.0	11.6	57.1	40.7	4.7	73.2	12.1	92.1	5.6	73.1	108.0	4.9
	15.00	9.6	22.2	57.8	40.9	4.5	73.3	12.7	93.6	5.6	74.5	109.0	4.9
100	7.50	2.1	4.9	51.7	38.9	5.7	71.0	9.1	Operation Not Recommended				
	11.25	4.9	11.3	53.5	39.3	5.3	71.5	10.2					
	15.00	9.4	21.7	54.2	39.4	5.1	71.5	10.7					
110	7.50	2.0	4.6	48.5	38.2	6.3	70.2	7.6					
	11.25	4.8	11.1	49.8	38.1	5.9	69.9	8.4					
	15.00	9.2	21.3	50.6	38.2	5.7	70.0	8.9					
120	7.50	2.0	4.6	44.7	37.5	7.1	69.0	6.3					
	11.25	4.7	10.9	46.0	37.1	6.6	68.6	6.9					
	15.00	9.0	20.8	46.8	37.0	6.4	68.6	7.3					

Interpolation is permissible; extrapolation is not.
 All entering air conditions are 80°F DB and 67°F WB in cooling, and 70°F DB in heating.
 Table does not reflect fan or pump power corrections for AHR/ISO conditions.
 All performance is based upon the lower voltage of dual voltage rated units.
 Performance stated is at the rated power supply; performance may vary as the power supply varies from the rated.
 Operation below 40°F EWT is based upon a 15% methanol antifreeze solution.
 Operation below 60°F EWT requires optional insulated water/refrigerant circuit.
 See performance correction tables for operating conditions other than those listed above.
 See Performance Data Selection Notes for operation in the shaded areas.

Performance Correction Tables for Units

Entering Air Correction Table – Cooling

Cooling Corrections												
Ent Air WB F	Total Clg Cap	Sens Clg Cap Multipliers- Entering DB °F									Power	Heat of Rejection
		60	65	70	75	80	80.6	85	90	95		
50	0.78	0.86	0.98	*	*	*	*	*	*	*	1.00	0.82
55	0.83	0.77	0.90	1.06	*	*	*	*	*	*	1.00	0.87
60	0.90		0.75	0.92	1.11	*	*	*	*	*	1.00	0.92
65	0.97			0.68	0.90	1.12	1.15	1.34	*	*	1.00	0.97
66.2	0.99			0.61	0.84	1.07	1.10	1.29	*	*	1.00	0.99
67	1.00			0.55	0.78	1.00	1.03	1.22	1.43	*	1.00	1.00
70	1.05				0.64	0.89	0.91	1.11	1.31	1.49	1.00	1.04
75	1.14					0.61	0.64	0.86	1.07	1.24	1.00	1.11

* Sensible capacity equals total capacity.
 AHR/ISO/ASHRAE 13256-1 uses entering air conditions of Cooling - 80.6 °F DB/ 66.2 °F WB, and Heating - 68 °F DB/ 59 °F WB entering air temperature.

Entering Air Correction Table – Heating

Heating Corrections			
Ent Air DB °F	Heating Capacity	Heating Power	Heat of Extraction
45	1.05	0.78	1.13
50	1.03	0.82	1.10
55	1.02	0.87	1.06
60	1.01	0.92	1.04
65	1.00	0.97	1.01
68	1.00	1.00	1.00
70	1.00	1.02	0.99
75	0.99	1.08	0.97
80	0.99	1.14	0.94

Airflow Correction Table

Airflow % of Rating	Heating			Cooling				
	Heating Capacity	Heating Power	Heat of Extraction	Total Capacity	Sensible Capacity	Sens/Total Ratio	Power	Heat of Rejection
75	0.98	1.11	0.94	0.96	0.88	0.92	0.96	0.96
81.25	0.98	1.08	0.96	0.97	0.91	0.94	0.97	0.97
87.5	0.99	1.05	0.97	0.98	0.94	0.95	0.98	0.98
93.75	0.99	1.02	0.99	0.99	0.97	0.97	0.99	0.99
100	1.00	1.00	1.00	1.00	1.00	1.00	1.00	1.00
106.25	1.00	0.98	1.01	1.01	1.04	1.04	1.01	1.01
112.5	1.01	0.97	1.02	1.01	1.10	1.09	1.03	1.01
118.75	1.01	0.96	1.03	1.01	1.18	1.17	1.04	1.02
125	1.02	0.95	1.04	1.01	1.28	1.27	1.05	1.02

Antifreeze Correction Table

EWT	Antifreeze Type	Antifreeze %	Cooling			Heating		WPD
			Total Cap	Sensible Cap	Watts	Total Cap	Watts	
90	Water	0%	1.000	1.000	1.000	1.000	1.000	1.000
	Ethanol	5%	0.998	0.998	1.002	0.996	0.999	1.025
		10%	0.996	0.996	1.003	0.991	0.997	1.048
		15%	0.994	0.994	1.005	0.987	0.996	1.098
		20%	0.991	0.991	1.006	0.982	0.994	1.142
		25%	0.986	0.986	1.009	0.972	0.991	1.207
		30%	0.981	0.981	1.012	0.962	0.988	1.265
		35%	0.977	0.977	1.015	0.953	0.985	1.312
		40%	0.972	0.972	1.018	0.943	0.982	1.370
		45%	0.966	0.966	1.023	0.931	0.978	1.431
		50%	0.959	0.959	1.027	0.918	0.974	1.494
	Ethylene Glycol	5%	0.998	0.998	1.002	0.996	0.999	1.021
		10%	0.996	0.996	1.003	0.991	0.997	1.040
		15%	0.994	0.994	1.004	0.987	0.996	1.079
		20%	0.991	0.991	1.005	0.982	0.995	1.114
		25%	0.988	0.988	1.008	0.976	0.993	1.146
		30%	0.985	0.985	1.010	0.969	0.990	1.175
		35%	0.982	0.982	1.012	0.963	0.988	1.208
		40%	0.979	0.979	1.014	0.956	0.986	1.243
		45%	0.976	0.976	1.016	0.950	0.984	1.278
		50%	0.972	0.972	1.018	0.943	0.982	1.314
	Methanol	5%	0.997	0.997	1.002	0.993	0.998	1.039
		10%	0.993	0.993	1.004	0.986	0.996	1.075
		15%	0.990	0.990	1.007	0.979	0.994	1.116
		20%	0.986	0.986	1.009	0.972	0.991	1.154
		25%	0.982	0.982	1.012	0.964	0.989	1.189
		30%	0.978	0.978	1.014	0.955	0.986	1.221
		35%	0.974	0.974	1.017	0.947	0.984	1.267
		40%	0.970	0.970	1.020	0.939	0.981	1.310
		45%	0.966	0.966	1.023	0.930	0.978	1.353
		50%	0.961	0.961	1.026	0.920	0.975	1.398
	Propylene Glycol	5%	0.995	0.995	1.003	0.990	0.997	1.065
		10%	0.990	0.990	1.006	0.980	0.994	1.119
		15%	0.986	0.986	1.009	0.971	0.991	1.152
		20%	0.981	0.981	1.012	0.962	0.988	1.182
		25%	0.978	0.978	1.014	0.956	0.986	1.227
		30%	0.975	0.975	1.016	0.950	0.984	1.267
		35%	0.972	0.972	1.018	0.944	0.982	1.312
		40%	0.969	0.969	1.020	0.938	0.980	1.356
		45%	0.965	0.965	1.023	0.929	0.977	1.402
		50%	0.960	0.960	1.026	0.919	0.974	1.450

Table Continued on Next Page

ClimateMaster works continually to improve its products. As a result, the design and specifications of each product at the time of order may be changed without notice and may not be as described herein. Please contact ClimateMaster's Customer Service Department at 1-405-745-6000 for specific information on the current design and specifications. Statements and other information contained herein are not express warranties and do not form the basis of any bargain between the parties, but are merely ClimateMaster's opinion or commendation of its products. The latest version of this document is available at climatemaster.com. © ClimateMaster, Inc. All rights reserved 2009

Antifreeze Correction Table

Table Continued from Previous Page

EWT	Antifreeze Type	Antifreeze %	Cooling			Heating		WPD
			Total Cap	Sensible Cap	Watts	Total Cap	Watts	
30	Water	0%	1.000	1.000	1.000	1.000	1.000	1.000
	Ethanol	5%	0.991	0.991	1.006	0.981	0.994	1.140
		10%	0.981	0.981	1.012	0.961	0.988	1.242
		15%	0.973	0.973	1.018	0.944	0.983	1.295
		20%	0.964	0.964	1.024	0.927	0.977	1.343
		25%	0.959	0.959	1.028	0.917	0.974	1.363
		30%	0.954	0.954	1.031	0.907	0.970	1.383
		35%	0.949	0.949	1.035	0.897	0.967	1.468
		40%	0.944	0.944	1.038	0.887	0.964	1.523
		45%	0.940	0.940	1.041	0.880	0.962	1.580
		50%	0.936	0.936	1.043	0.872	0.959	1.639
	Ethylene Glycol	5%	0.997	0.997	1.002	0.993	0.998	1.040
		10%	0.993	0.993	1.004	0.986	0.996	1.075
		15%	0.990	0.990	1.006	0.980	0.994	1.122
		20%	0.987	0.987	1.008	0.973	0.992	1.163
		25%	0.983	0.983	1.011	0.966	0.990	1.195
		30%	0.979	0.979	1.013	0.958	0.987	1.225
		35%	0.976	0.976	1.016	0.951	0.985	1.279
		40%	0.972	0.972	1.018	0.943	0.982	1.324
		45%	0.969	0.969	1.021	0.937	0.980	1.371
		50%	0.966	0.966	1.023	0.930	0.978	1.419
	Methanol	5%	0.995	0.995	1.004	0.989	0.997	1.069
		10%	0.989	0.989	1.007	0.978	0.993	1.127
		15%	0.984	0.984	1.011	0.968	0.990	1.164
		20%	0.979	0.979	1.014	0.957	0.986	1.197
		25%	0.975	0.975	1.017	0.949	0.984	1.216
		30%	0.971	0.971	1.019	0.941	0.981	1.235
		35%	0.967	0.967	1.022	0.933	0.979	1.286
		40%	0.963	0.963	1.025	0.924	0.976	1.323
		45%	0.959	0.959	1.028	0.917	0.974	1.360
		50%	0.955	0.955	1.030	0.910	0.971	1.399
	Propylene Glycol	5%	0.995	0.995	1.004	0.989	0.997	1.071
		10%	0.989	0.989	1.007	0.978	0.993	1.130
		15%	0.985	0.985	1.010	0.968	0.990	1.206
		20%	0.980	0.980	1.013	0.958	0.987	1.270
		25%	0.974	0.974	1.017	0.947	0.983	1.359
		30%	0.968	0.968	1.021	0.935	0.979	1.433
		35%	0.963	0.963	1.025	0.924	0.976	1.522
		40%	0.957	0.957	1.029	0.913	0.972	1.614
		45%	0.949	0.949	1.034	0.898	0.967	1.712
		50%	0.941	0.941	1.039	0.882	0.962	1.816

ClimateMaster works continually to improve its products. As a result, the design and specifications of each product at the time of order may be changed without notice and may not be as described herein. Please contact ClimateMaster's Customer Service Department at 1-405-745-6000 for specific information on the current design and specifications. Statements and other information contained herein are not express warranties and do not form the basis of any bargain between the parties, but are merely ClimateMaster's opinion or commendation of its products. The latest version of this document is available at climatemaster.com. © ClimateMaster, Inc. All rights reserved 2009

Blower Performance Data – TC006

Rated CFM	Min CFM	Motor Type	Motor Speed Setting	External Static Pressure (in. wg)																
				0.1	0.2	0.3	0.4	0.5	0.6	0.7	0.8	0.9	1.0							
225	150	PSC	Low	CFM	210	190	160													
			Medium	CFM	260	240	210							190						
			High	CFM	310	290	270							230	180					
225	150	Constant Torque ECM	1	RPM	944	1028	1114	1206	1297											
				Power (W)	22	24	25	28	30											
				CFM	225	207	187	169	150											
			2	RPM				1201	1280						1362	1441	1523	1608	1694	
				Power (W)				34	37						39	42	44	48	51	
				CFM				233	217						201	185	173	164	150	
			3	RPM				1324	1400						1476	1551	1628	1709	1786	
				Power (W)				43	45						48	51	54	58	61	
				CFM				241	227						212	200	188	179	168	
			4	RPM											1516	1588	1658	1730	1799	
				Power (W)											55	58	61	65	67	
				CFM											240	227	216	205	193	
225	150	Constant Volume ECM	Minimum CFM	RPM	763	933	1078	1201	1314	1417	1519	1615	1712							
				Power (W)	16	21	27	40	36	41	46	52	59							
				CFM	150	150	150	150	150	150	150	150	150							
			Default CFM	RPM	983	1102	1211	1319	1419	1516	1610	1708	1783	1817						
				Power (W)	29	35	41	47	53	60	67	76	81	77						
				CFM	225	225	225	225	225	225	225	225	225	255						
			Maximum CFM	RPM	1053	1162	1265	1366	1462	1553	1648	1733	1802	1817						
				Power (W)	35	41	47	53	60	67	76	84	88	78						
				CFM	250	250	250	250	250	250	250	250	250	250						

See ECM control section for details on setting airflow.
 Airflow is controlled within 5% up to the Max ESP shown with wet coil.
 Do not select Dehumidification mode if HP CFM is on setting 1.
 Black areas denote ESP where operation is not recommended.
 PSC: Units factory shipped on medium speed. Other speeds require field selection.
 CT ECM: Units factory shipped on Speed Tap 2 for Fan-Only and Speed Tap 3 for Heating/Cooling.
 All airflow is rated and shown above at the lower voltage if unit is dual voltage rated, e.g. 208V for 208-230V units.
 Only two speed PSC fan (H & M) available on 575V units.
 Performance stated is at the rated power supply. Performance may vary as the power supply varies from the rated.
 All data is shown wet coil with clean 1" filter.
 All data is ran at 80 °F DB and 67 °F WB.
 CFM Tolerance is 7%.
 RPM/Watt Tolerance 10%.

Blower Performance Data – TC009

Rated CFM	Min CFM	Motor Type	Motor Speed Setting	External Static Pressure (in. wg)													
				0.1	0.2	0.3	0.4	0.5	0.6	0.7	0.8	0.9	1.0				
325	225	PSC	Low	CFM	340	322	300	260									
			Medium	CFM	390	360	320	290							260		
			High	CFM	410	380	350	320							280		
325	225	Constant Torque ECM	1	RPM	1137	1203	1266	1344	1413								
				Power (W)	40	42	44	47	49								
				CFM	294	278	259	245	230								
			2	RPM	1361	1413	1464	1503	1577	1640	1700	1751	1803	1831			
				Power (W)	67	70	73	74	79	82	85	88	90	85			
				CFM	370	357	343	326	318	302	291	278	265	235			
			3	RPM				1538	1589	1642	1695	1749	1812	1829	1847		
				Power (W)				86	88	91	95	98	101	96	90		
				CFM				370	358	346	334	322	307	280	247		
			4	RPM							1835	1853	1869	1875			
				Power (W)							120	113	107	102			
				CFM							340	309	276	234			
325	225	Constant Volume ECM	Minimum CFM	RPM	929	1083	1210	1324	1432	1529	1595	1723	1792				
				Power (W)	25	32	39	45	53	60	66	78	83				
				CFM	225	225	225	225	225	225	225	225	225				
			Default CFM	RPM	1209	1326	1430	1535	1635	1732	1792	1801	1811				
				Power (W)	49	58	67	77	88	100	105	95	88				
				CFM	325	325	325	325	325	325	325	325	325				
			Maximum CFM	RPM	1691	1753	1765	1769	1778	1784	1793	1803	1813				
				Power (W)	126	134	131	125	119	118	105	98	90				
				CFM	375	375	375	375	375	375	375	375	375				

See ECM control section for details on setting airflow.
 Airflow is controlled within 5% up to the Max ESP shown with wet coil.
 Do not select Dehumidification mode if HP CFM is on setting 1.
 Black areas denote ESP where operation is not recommended.
 PSC: Units factory shipped on medium speed. Other speeds require field selection.
 CT ECM: Units factory shipped on Speed Tap 2 for Fan-Only and Speed Tap 3 for Heating/Cooling.
 All airflow is rated and shown above at the lower voltage if unit is dual voltage rated, e.g. 208V for 208-230V units.
 Only two speed PSC fan (H & M) available on 575V units.
 Performance stated is at the rated power supply. Performance may vary as the power supply varies from the rated.
 All data is shown wet coil with clean 1" filter.
 All data is ran at 80 °F DB and 67 °F WB.
 CFM Tolerance is 7%.
 RPM/Watt Tolerance 10%.

Blower Performance Data – TC012

Rated CFM	Min CFM	Motor Type	Motor Speed Setting	External Static Pressure (in. wg)											
				0.1	0.2	0.3	0.4	0.5	0.6	0.7	0.8	0.9	1.0		
380	300	PSC	Low	CFM	360	350	320	310							
			Medium	CFM	420	400	380	360							340
			High	CFM	470	450	430	400							380
380	300	Constant Torque ECM	1	RPM	1338	1385	1436	1491	1551						
				Power (W)	64	66	69	71	75						
				CFM	358	345	332	319	305						
			2	RPM	1477	1517	1561	1612	1660	1711	1769	1819			
				Power (W)	86	88	91	94	97	100	103	104			
				CFM	400	388	377	365	354	342	328	309			
			3	RPM	1632	1672	1709	1747	1785	1820	1835	1856			
				Power (W)	116	119	122	124	126	126	121	114			
				CFM	449	437	427	414	401	385	359	327			
			4	RPM	1698	1729	1765	1798	1821	1836	1842	1843			
				Power (W)	131	133	135	137	135	130	123	110			
				CFM	467	456	444	433	414	390	361	318			
380	300	Constant Volume ECM	Minimum CFM	RPM	1258	1368	1464	1555	1635	1718	1793	1830			
				Power (W)	55	64	73	81	90	99	107	106			
				CFM	300	300	300	300	300	300	300	300			
			Default CFM	RPM	1598	1672	1743	1813	1831	1845	1859	1875			
				Power (W)	105	115	125	135	132	127	123	118			
				CFM	380	380	380	380	380	380	380	380			
			Maximum CFM	RPM	1798	1823	1834	1844	1858	1872	1886	1901	1920		
				Power (W)	147	149	146	143	139	134	130	126	120		
				CFM	415	415	415	415	415	415	415	415	415		

See ECM control section for details on setting airflow.
 Airflow is controlled within 5% up to the Max ESP shown with wet coil.
 Do not select Dehumidification mode if HP CFM is on setting 1.
 Black areas denote ESP where operation is not recommended.
 PSC: Units factory shipped on medium speed. Other speeds require field selection.
 CT ECM: Units factory shipped on Speed Tap 2 for Fan-Only and Speed Tap 3 for Heating/Cooling.
 All airflow is rated and shown above at the lower voltage if unit is dual voltage rated, e.g. 208V for 208-230V units.
 Only two speed PSC fan (H & M) available on 575V units.
 Performance stated is at the rated power supply. Performance may vary as the power supply varies from the rated.
 All data is shown wet coil with clean 1" filter.
 All data is ran at 80 °F DB and 67 °F WB.
 CFM Tolerance is 7%.
 RPM/Watt Tolerance 10%.

Blower Performance Data – TC015

Rated CFM	Min CFM	Motor Type	Motor Speed Setting	External Static Pressure (in. wg)												
				0.1	0.2	0.3	0.4	0.5	0.6	0.7	0.8	0.9	1.0			
525	375	PSC	Low	CFM	503	490	479	439								
			Medium	CFM	595	575	562	510	451							
			High	CFM					581	510	386					
525	375	PSC - High Static	Low	CFM	462	456	443	425	385							
			Medium	CFM	546	539	531	513	481	414						
			High	CFM						547	426					
525	375	Constant Torque ECM	1	RPM	655	614	701	770	851	937						
				Power (W)	67	55	62	68	75	82						
				CFM	648	588	542	493	441	378						
			2	RPM	655	720	799	863	946	1021	1078					
				Power (W)	67	74	81	87	95	102	108					
				CFM	648	608	557	514	460	402	354					
			3	RPM	687	744	822	883	950	1032	1098	1150				
				Power (W)	79	86	94	101	107	117	124	130				
				CFM	695	659	611	570	526	475	422	377				
			4	RPM	716	771	844	906	965	1037	1110	1170	1219			
				Power (W)	92	98	107	114	121	129	138	145	151			
				CFM	737	705	661	622	582	534	482	438	396			
			5	RPM	763	790	851	924	978	1039	1113	1175	1233	1281		
				Power (W)	106	110	117	126	133	141	151	159	165	172		
				CFM	745	745	708	662	626	585	535	488	444	402		
525	375	Constant Volume ECM	Minimum CFM	RPM			617	741	848	945	1028	1103	1171			
				Power (W)			36	52	68	84	99	114	129			
				CFM			375	375	375	375	375	375	375			
			Default CFM	RPM			661	767	859	944	1028	1107	1179	1247		
				Power (W)			55	74	90	108	127	147	166	186		
				CFM			525	525	525	525	525	525	525	525		
			Maximum CFM	RPM			586	695	795	882	963	1038	1111	1180	1248	1312
				Power (W)			54	73	93	112	132	152	173	194	216	238
				CFM			625	625	625	625	625	625	625	625	625	625

See ECM control section for details on setting airflow.
 Airflow is controlled within 5% up to the Max ESP shown with wet coil.
 Do not select Dehumidification mode if HP CFM is on setting 1.
 Black areas denote ESP where operation is not recommended.
 PSC: Units factory shipped on medium speed. Other speeds require field selection.
 CT ECM: Units factory shipped on Speed Tap 2 for Fan-Only and Speed Tap 3 for Heating/Cooling.
 All airflow is rated and shown above at the lower voltage if unit is dual voltage rated, e.g. 208V for 208-230V units.
 Only two speed PSC fan (H & M) available on 575V units.
 Performance stated is at the rated power supply. Performance may vary as the power supply varies from the rated.
 All data is shown wet coil with clean 1" filter.
 All data is ran at 80 °F DB and 67 °F WB.
 CFM Tolerance is 7%.
 RPM/Watt Tolerance 10%.

Blower Performance Data – TC018

Rated CFM	Min CFM	Motor Type	Motor Speed Setting	External Static Pressure (in. wg)											
				0.1	0.2	0.3	0.4	0.5	0.6	0.7	0.8	0.9	1.0		
600	450	PSC	Low	CFM	524	509	493	451							
			Medium	CFM	611	588	564	514							
			High	CFM	704	668	643	617	504						
600	450	PSC - High Static	Low	CFM	461										
			Medium	CFM	553	543	533	506	468						
			High	CFM	670	661	645	628	587	534					
600	450	Constant Torque ECM	1	RPM	693	763	837	882							
				Power (W)	73	78	85	90							
				CFM	600	558	518	491							
			2	RPM	745	801	873	904	966	1031	1098				
				Power (W)	92	99	107	109	116	123	131				
				CFM	676	641	599	570	536	498	452				
			3	RPM	782	831	890	958	992	1048	1106	1171	1223		
				Power (W)	112	118	126	135	140	147	155	163	170		
				CFM	741	713	677	640	619	586	554	512	471		
			4	RPM	833	875	924	986	1046	1072	1124	1177	1236	1290	
				Power (W)	138	144	152	161	170	174	181	190	199	207	
				CFM	802	780	751	714	680	662	633	603	567	529	
			5	RPM	895	924	968	1016	1078	1133	1151	1199	1249	1302	
				Power (W)	170	175	182	190	201	210	214	222	231	240	
				CFM	854	848	820	791	754	724	711	683	655	625	
600	450	Constant Volume ECM	Minimum CFM	RPM					1096	1179	1275	1361			
				Power (W)					111	132	157	180			
				CFM					450	450	450	450			
			Default CFM	RPM	847	918	971	1095	1208	1297	1360	1418	1467		
				Power (W)	85	101	113	145	178	206	228	248	266		
				CFM	600	600	600	600	600	600	600	600	600		
			Maximum CFM	RPM	1036	1080	1131	1172	1213	1317	1406	1494			
				Power (W)	157	171	186	200	214	251	286	323			
				CFM	750	750	750	750	750	750	750	750			

See ECM control section for details on setting airflow.
 Airflow is controlled within 5% up to the Max ESP shown with wet coil.
 Do not select Dehumidification mode if HP CFM is on setting 1.
 Black areas denote ESP where operation is not recommended.
 PSC: Units factory shipped on medium speed. Other speeds require field selection.
 CT ECM: Units factory shipped on Speed Tap 2 for Fan-Only and Speed Tap 3 for Heating/Cooling.
 All airflow is rated and shown above at the lower voltage if unit is dual voltage rated, e.g. 208V for 208-230V units.
 Only two speed PSC fan (H & M) available on 575V units.
 Performance stated is at the rated power supply. Performance may vary as the power supply varies from the rated.
 All data is shown wet coil with clean 1" filter.
 All data is ran at 80 °F DB and 67 °F WB.
 CFM Tolerance is 7%.
 RPM/Watt Tolerance 10%.

Blower Performance Data – TC024

Rated CFM	Min CFM	Motor Type	Motor Speed Setting	External Static Pressure (in. wg)												
				0.1	0.2	0.3	0.4	0.5	0.6	0.7	0.8	0.9	1.0			
850	600	PSC	Low	CFM	760	741	722	694	665	618						
			Medium	CFM	941	912	874	836	789	732						665
			High	CFM					950	884						827
850	600	PSC - High Static	Low	CFM									979	931	884	827
			Medium	CFM									988	922	846	713
			High	CFM									979	903	798	665
800	600	Constant Torque ECM	1	RPM	817	865	915	973								
				Power (W)	116	122	128	135								
				CFM	755	728	695	653								
			2	RPM	877	920	966	1012	1070	1142	1198					
				Power (W)	146	152	159	166	174	185	193					
				CFM	836	810	782	750	708	657	616					
			3	RPM	938	974	1017	1057	1102	1158	1227	1283	1323	1355		
				Power (W)	181	187	194	201	209	218	230	239	246	252		
				CFM	910	887	861	834	804	762	714	674	642	619		
			4	RPM	1015	1048	1084	1121	1159	1199	1244	1309	1369	1412		
				Power (W)	232	240	247	254	262	270	278	291	303	312		
				CFM	996	975	952	929	904	876	845	798	755	725		
			5	RPM						1219	1255	1293	1331	1384	1446	
				Power (W)						323	331	340	348	361	374	
				CFM						999	975	951	923	884	840	
800	600	Constant Volume ECM	Minimum CFM	RPM	706	788	867	941	1013	1080	1143	1203	1259	1311		
				Power (W)	71	89	107	124	141	159	177	195	213	230		
				CFM	600	600	600	600	600	600	600	600	600	600		
			Default CFM	RPM	882	943	1002	1059	1114	1168	1220	1271	1319	1366		
				Power (W)	145	165	185	205	225	245	266	285	306	326		
				CFM	800	800	800	800	800	800	800	800	800	800		
			Maximum CFM	RPM	1077	1122	1162	1200	1233	1263	1288	1310	1329	1343		
				Power (W)	284	300	315	332	351	364	379	396	412	428		
				CFM	1000	1000	1000	1000	1000	1000	1000	1000	1000	1000		

See ECM control section for details on setting airflow.
 Airflow is controlled within 5% up to the Max ESP shown with wet coil.
 Do not select Dehumidification mode if HP CFM is on setting 1.
 Black areas denote ESP where operation is not recommended.
 PSC: Units factory shipped on medium speed. Other speeds require field selection.
 CT ECM: Units factory shipped on Speed Tap 2 for Fan-Only and Speed Tap 3 for Heating/Cooling.
 All airflow is rated and shown above at the lower voltage if unit is dual voltage rated, e.g. 208V for 208-230V units.
 Only two speed PSC fan (H & M) available on 575V units.
 Performance stated is at the rated power supply. Performance may vary as the power supply varies from the rated.
 All data is shown wet coil with clean 1" filter.
 All data is ran at 80 °F DB and 67 °F WB.
 CFM Tolerance is 7%.
 RPM/Watt Tolerance 10%.

Blower Performance Data – TC030

Rated CFM	Min CFM	Motor Type	Motor Speed Setting	External Static Pressure (in. wg)													
				0.1	0.2	0.3	0.4	0.5	0.6	0.7	0.8	0.9	1.0				
1000	750	PSC	Low	CFM	1017	979	931	884	827	751							
			Medium	CFM	1140	1093	1036	988	922	846							
			High	CFM			1102	1045	979	903						798	
Low	CFM	979	941	912			865	798									
1000	750	PSC - High Static	Medium	CFM				1074						979	884	779	
			High	CFM										1102	988	874	760
			1000	750	Constant Torque ECM	1	RPM				880	925	994	1049	1101		
Power (W)	158	165					176	184	192								
CFM	904	873					832	796	763								
2	RPM	956				998	1038	1105	1156	1203	1248	1295	1344				
	Power (W)	211				219	227	240	250	258	267	276	285				
	CFM	1020				992	965	927	894	864	835	805	771				
3	RPM	1034				1072	1110	1145	1209	1250	1303	1346	1387	1422			
	Power (W)	280				289	298	306	321	330	342	351	361	368			
	CFM	1139				1113	1089	1064	1027	999	966	937	910	879			
4	RPM	1095				1130	1166	1201	1237	1299	1337	1387	1428	1465			
	Power (W)	336				346	355	364	374	389	399	413	423	430			
	CFM	1216				1193	1168	1146	1123	1086	1062	1028	1002	975			
5	RPM					1268	1301	1333	1394	1426	1473	1491					
	Power (W)					452	462	471	490	499	508	478					
	CFM					1250	1229	1208	1173	1151	1112	1036					
1000	750	Constant Volume ECM	Minimum CFM	RPM	872	928	990	1046	1096	1143	1192	1238	1282	1327			
				Power (W)	71	89	108	127	145	162	181	199	217	235			
				CFM	750	750	750	750	750	750	750	750	750	750			
			Default CFM	RPM	1131	1177	1218	1252	1295	1337	1381	1415					
				Power (W)	251	274	296	315	337	362	387	407					
				CFM	1000	1000	1000	1000	1000	1000	1000	1000					
			Maximum CFM	RPM	1260	1299	1334	1373	1403								
				Power (W)	388	410	431	453	471								
				CFM	1150	1150	1150	1150	1150								

See ECM control section for details on setting airflow.
 Airflow is controlled within 5% up to the Max ESP shown with wet coil.
 Do not select Dehumidification mode if HP CFM is on setting 1.
 Black areas denote ESP where operation is not recommended.
 PSC: Units factory shipped on medium speed. Other speeds require field selection.
 CT ECM: Units factory shipped on Speed Tap 2 for Fan-Only and Speed Tap 3 for Heating/Cooling.
 All airflow is rated and shown above at the lower voltage if unit is dual voltage rated, e.g. 208V for 208-230V units.
 Only two speed PSC fan (H & M) available on 575V units.
 Performance stated is at the rated power supply. Performance may vary as the power supply varies from the rated.
 All data is shown wet coil with clean 1" filter.
 All data is ran at 80 °F DB and 67 °F WB.
 CFM Tolerance is 7%.
 RPM/Watt Tolerance 10%.

Blower Performance Data – TC036

Rated CFM	Min CFM	Motor Type	Motor Speed Setting	External Static Pressure (in. wg)													
				0.1	0.2	0.3	0.4	0.5	0.6	0.7	0.8	0.9	1.0				
1150	900	PSC	Low	CFM	970	960	951	941	902								
			Medium	CFM	1106	1096	1086	1067	1009							912	
			High	CFM	1436	1387	1329	1280	1174							1077	931
1150	900	PSC - High Static	Low	CFM	980	970	960	931	902								
			Medium	CFM	1300	1280	1261	1222	1193							1116	1038
			High	CFM				1484	1426							1358	1251
1150	900	Constant Torque ECM	1	RPM	842	891	945										
				Power (W)	166	175	184										
				CFM	974	941	904										
			2	RPM	936	983	1028	1075	1125	1167	1203	1241					
				Power (W)	241	251	261	272	282	292	299	307					
				CFM	1132	1103	1074	1041	1005	973	944	916					
			3	RPM	988	1032	1076	1117	1160	1205	1246	1282	1315	1354			
				Power (W)	294	304	316	326	337	349	359	367	375	385			
				CFM	1271	1242	1214	1185	1153	1118	1083	1056	1029	999			
			4	RPM	1056	1090	1130	1170	1208	1250	1292	1332	1370	1403			
				Power (W)	376	387	399	409	421	433	446	457	468	478			
				CFM	1403	1377	1351	1324	1295	1268	1233	1201	1169	1143			
			5	RPM			1193	1228	1265	1295	1323	1358	1392	1419			
				Power (W)			499	510	523	524	521	519	516	514			
				CFM			1485	1460	1434	1396	1347	1295	1240	1194			
1150	900	Constant Volume ECM	Minimum CFM	RPM	682	788	898	976	1043	1107	1170	1230	1297	1371			
				Power (W)	105	132	164	188	211	233	257	280	307	339			
				CFM	900	900	900	900	900	900	900	900	900	900			
			Default CFM	RPM	830	895	961	1054	1145	1209	1267	1321	1371	1419			
				Power (W)	205	232	261	303	349	382	415	446	475	505			
				CFM	1150	1150	1150	1150	1150	1150	1150	1150	1150	1150			
			Maximum CFM	RPM	1042	1040	1095	1149	1199	1273	1355	1420	1459	1493			
				Power (W)	406	403	438	474	511	564	629	680	692	691			
				CFM	1500	1500	1500	1500	1500	1500	1500	1500	1500	1500			

See ECM control section for details on setting airflow.
 Airflow is controlled within 5% up to the Max ESP shown with wet coil.
 Do not select Dehumidification mode if HP CFM is on setting 1.
 Black areas denote ESP where operation is not recommended.
 PSC: Units factory shipped on medium speed. Other speeds require field selection.
 CT ECM: Units factory shipped on Speed Tap 2 for Fan-Only and Speed Tap 3 for Heating/Cooling.
 All airflow is rated and shown above at the lower voltage if unit is dual voltage rated, e.g. 208V for 208-230V units.
 Only two speed PSC fan (H & M) available on 575V units.
 Performance stated is at the rated power supply. Performance may vary as the power supply varies from the rated.
 All data is shown wet coil with clean 1" filter.
 All data is ran at 80 °F DB and 67 °F WB.
 CFM Tolerance is 7%.
 RPM/Watt Tolerance 10%.

Blower Performance Data – TC041

Rated CFM	Min CFM	Motor Type	Motor Speed Setting	External Static Pressure (in. wg)											
				0.1	0.2	0.3	0.4	0.5	0.6	0.7	0.8	0.9	1.0		
1125	845	PSC	Low	CFM	1008	971									
			Medium	CFM	1142	1090									1023
			High	CFM	1269	1198									1114

Airflow is controlled within 5% up to the Max ESP shown with wet coil.
 Do not select Dehumidification mode if HP CFM is on setting 1.
 Black areas denote ESP where operation is not recommended.
 Units factory shipped on medium speed. Other speeds require field selection.
 All airflow is rated and shown above at the lower voltage if unit is dual voltage rated, e.g. 208V for 208-230V units.
 Only two speed fan (H & M) available on 575V units.
 Performance stated is at the rated power supply. Performance may vary as the power supply varies from the rated.
 All data is shown wet coil with clean 1" filter.
 All data is ran at 80 °F DB and 67 °F WB.
 CFM Tolerance is 7%.
 RPM/Watt Tolerance 10%.

Blower Performance Data – TC042

Rated CFM	Min CFM	Motor Type	Motor Speed Setting	External Static Pressure (in. wg)																
				0.1	0.2	0.3	0.4	0.5	0.6	0.7	0.8	0.9	1.0							
1400	1050	PSC	Low	CFM	1074	1064														
			Medium	CFM	1368	1321											1273	1207	1131	1064
			High	CFM	1501	1444											1378	1302	1226	1131
1400	1050	PSC - High Static	Low	CFM																
			Medium	CFM											1302	1283	1254	1235	1188	1121
			High	CFM												1473	1444	1397	1378	1311
1400	1050	Constant Torque ECM	1	RPM	916	957	1004	1065												
				Power (W)	238	248	259	272												
				CFM	1186	1152	1113	1056												
			2	RPM	1013	1050	1084	1128	1179	1227	1279	1317	1356	1400						
				Power (W)	331	369	352	365	381	396	411	423	437	446						
				CFM	1345	1317	1283	1251	1215	1181	1150	1124	1094	1050						
			3	RPM	1108	1142	1178	1207	1247	1293	1336	1382	1426	1462						
				Power (W)	448	461	474	486	501	518	534	551	568	581						
				CFM	1507	1482	1455	1427	1396	1365	1331	1296	1276	1246						
			4	RPM	1200	1231	1263	1292	1321	1356	1397	1440	1479	1505						
				Power (W)	582	595	609	622	635	651	669	688	706	681						
				CFM	1641	1623	1601	1577	1548	1519	1488	1455	1423	1355						
			5	RPM			1317	1372	1392	1412	1436	1469	1500	1504						
				Power (W)			756	775	776	774	772	768	765	679						
				CFM			1743	1717	1688	1645	1596	1541	1490	1352						
1400	1050	Constant Volume ECM	Minimum CFM	RPM	786	855	920	985	1059	1125	1186	1240	1292	1346						
				Power (W)	154	177	200	224	252	280	306	331	355	383						
				CFM	1050	1050	1050	1050	1050	1050	1050	1050	1050	1050	1050					
			Default CFM	RPM	997	1042	1094	1145	1193	1241	1292	1345	1400	1451						
				Power (W)	334	359	390	421	453	484	517	555	595	636						
				CFM	1400	1400	1400	1400	1400	1400	1400	1400	1400	1400	1400					
			Maximum CFM	RPM	1224	1245	1282	1305	1327											
				Power (W)	658	674	703	700	697											
				CFM	1750	1750	1750	1750	1750											

See ECM control section for details on setting airflow.
 Airflow is controlled within 5% up to the Max ESP shown with wet coil.
 Do not select Dehumidification mode if HP CFM is on setting 1.
 Black areas denote ESP where operation is not recommended.
 PSC: Units factory shipped on medium speed. Other speeds require field selection.
 CT ECM: Units factory shipped on Speed Tap 2 for Fan-Only and Speed Tap 3 for Heating/Cooling.
 All airflow is rated and shown above at the lower voltage if unit is dual voltage rated, e.g. 208V for 208-230V units.
 Only two speed PSC fan (H & M) available on 575V units.
 Performance stated is at the rated power supply. Performance may vary as the power supply varies from the rated.
 All data is shown wet coil with clean 1" filter.
 All data is ran at 80 °F DB and 67 °F WB.
 CFM Tolerance is 7%.
 RPM/Watt Tolerance 10%.

Blower Performance Data – TC048

Rated CFM	Min CFM	Motor Type	Motor Speed Setting	External Static Pressure (in. wg)												
				0.1	0.2	0.3	0.4	0.5	0.6	0.7	0.8	0.9	1.0			
1600	1200	PSC	Low	CFM	1644	1606	1568	1492	1378	1264						
			Medium	CFM	1805	1767	1682	1625	1520	1340						
			High	CFM		1881	1815	1710	1596	1416	1216	1216				
1600	1200	PSC - High Static	Low	CFM	1748	1720	1691	1644	1587	1520	1435	1311				
			Medium	CFM	1938	1891	1843	1796	1739	1691	1625	1539	1416	1254		
			High	CFM				1957	1910	1862	1786	1701	1577	1435		
1500	1200	Constant Torque ECM	1	RPM	767	811	848	886	935							
				Power (W)	225	237	247	257	270							
				CFM	1397	1349	1304	1259	1202							
			2	RPM	826	869	905	940	979	1026	1073					
				Power (W)	287	300	312	322	334	349	363					
				CFM	1527	1484	1441	1398	1351	1294	1240					
			3	RPM	881	925	960	993	1027	1064	1108	1150	1214			
				Power (W)	358	374	387	398	410	423	439	454	473			
				CFM	1660	1619	1577	1537	1494	1452	1399	1349	1254			
			4	RPM	959	997	1034	1064	1093	1124	1157	1195	1206			
				Power (W)	474	491	507	521	533	546	560	576	511			
				CFM	1837	1795	1760	1722	1685	1647	1608	1560	1382			
			5	RPM			1078	1113	1145	1174	1200	1213	1200			
				Power (W)			649	667	684	698	714	695	588			
				CFM			1993	1956	1919	1886	1854	1784	1588			
1500	1200	Constant Volume ECM	Minimum CFM	RPM	703	766	827	886	943	998	1051	1102	1150	1196		
				Power (W)	174	205	237	269	302	336	371	407	444	482		
				CFM	1200	1200	1200	1200	1200	1200	1200	1200	1200	1200	1200	
			Default CFM	RPM	833	884	932	986	1043	1089	1137	1191	1242	1293		
				Power (W)	287	329	369	412	455	495	536	578	620	662		
				CFM	1500	1500	1500	1500	1500	1500	1500	1500	1500	1500	1500	1500
			Maximum CFM	RPM	993	1038	1082	1129	1178	1220	1264	1311	1357	1402		
				Power (W)	562	616	669	724	781	832	885	940	994	1048		
				CFM	1900	1900	1900	1900	1900	1900	1900	1900	1900	1900	1900	1900

See ECM control section for details on setting airflow.
 Airflow is controlled within 5% up to the Max ESP shown with wet coil.
 Do not select Dehumidification mode if HP CFM is on setting 1.
 Black areas denote ESP where operation is not recommended.
 PSC: Units factory shipped on medium speed. Other speeds require field selection.
 CT ECM: Units factory shipped on Speed Tap 2 for Fan-Only and Speed Tap 3 for Heating/Cooling.
 All airflow is rated and shown above at the lower voltage if unit is dual voltage rated, e.g. 208V for 208-230V units.
 Only two speed PSC fan (H & M) available on 575V units.
 Performance stated is at the rated power supply. Performance may vary as the power supply varies from the rated.
 All data is shown wet coil with clean 1" filter.
 All data is ran at 80 °F DB and 67 °F WB.
 CFM Tolerance is 7%.
 RPM/Watt Tolerance 10%.

Blower Performance Data – TC060

Rated CFM	Min CFM	Motor Type	Motor Speed Setting		External Static Pressure (in. wg)										
					0.1	0.2	0.3	0.4	0.5	0.6	0.7	0.8	0.9	1.0	
1950	1500	PSC	Low	CFM	1803	1774	1744	1695	1637	1568					
			Medium	CFM	1999	1950	1901	1852	1793	1744	1676	1588			
			High	CFM		1881	1815	1710	1596	1416	1216	1216			
1950	1500	PSC - High Static	Low	CFM	1882	1872	1852	1842	1813	1793	1764	1715	1666	1588	
			Medium	CFM	2107	2097	2038	1999	1980	1940	1891	1842	1460	1715	
			High	CFM	2342	2323	2293	2254	2195	2156	2087	2019	1940	1852	
1950	1500	Constant Torque ECM	1	RPM	768	797	830	863							
				Power (W)	342	354	366	380							
				CFM	1685	1640	1593	1545							
			2	RPM	836	867	895	922	955	989	1020	1048	1081		
				Power (W)	460	476	489	501	518	533	548	561	577		
				CFM	1879	1833	1795	1754	1705	1657	1608	1563	1514		
			3	RPM	923	953	974	1000	1025	1052	1079	1109	1137		
				Power (W)	648	666	678	694	708	724	740	757	773		
				CFM	2113	2069	2039	1998	1963	1925	1885	1840	1795		
			4	RPM	972	994	1020	1041	1066	1090	1114	1144	1170		
				Power (W)	771	785	803	817	832	848	864	883	900		
				CFM	2235	2198	2163	2130	2094	2061	2019	1977	1939		
			5	RPM	1003	1025	1050	1074	1099	1122	1147	1166	1194	1209	
				Power (W)	866	881	899	916	934	951	970	977	973	969	
				CFM	2322	2290	2253	2219	2188	2152	2120	2083	2013	1940	
1950	1500	Constant Volume ECM	Minimum CFM	RPM	705	773	836	894	949	998	1044	1085	1121	1153	
				Power (W)	246	301	354	405	453	500	544	587	627	665	
				CFM	1500	1500	1500	1500	1500	1500	1500	1500	1500	1500	1500
			Default CFM	RPM	852	899	949	992	1031	1085	1136	1179	1225	1272	
				Power (W)	501	562	629	683	731	804	871	926	986	1047	
				CFM	1950	1950	1950	1950	1950	1950	1950	1950	1950	1950	1950
			Maximum CFM	RPM	995	1020	1044	1069	1094						
				Power (W)	885	896	901	916	937						
				CFM	2200	2200	2200	2200	2200						

See ECM control section for details on setting airflow.
 Airflow is controlled within 5% up to the Max ESP shown with wet coil.
 Do not select Dehumidification mode if HP CFM is on setting 1.
 Black areas denote ESP where operation is not recommended.
 PSC: Units factory shipped on medium speed. Other speeds require field selection.
 CT ECM: Units factory shipped on Speed Tap 2 for Fan-Only and Speed Tap 3 for Heating/Cooling.
 All airflow is rated and shown above at the lower voltage if unit is dual voltage rated, e.g. 208V for 208-230V units.
 Only two speed PSC fan (H & M) available on 575V units.
 Performance stated is at the rated power supply. Performance may vary as the power supply varies from the rated.
 All data is shown wet coil with clean 1" filter.
 All data is ran at 80 °F DB and 67 °F WB.
 CFM Tolerance is 7%.
 RPM/Watt Tolerance 10%.

Waterside Economizer Data

WSE Cooling Performance Data

Model		Water Side			Airside		Capacity	
		FLOW (gpm)	PD (psi)	PD (ft)	CFM	PD (in. wg.)	TC	SC
Vertical	006	1.5	1.9	4.4	225	0.05	6.641	4.922
	009	2.3	3.2	7.3	300	0.07	8.288	6.631
	012	3.0	1.9	4.3	400	0.11	8.485	7.569
	015	3.8	2.6	5.9	500	0.06	15.467	12.181
	018	4.5	3.5	8.2	600	0.09	17.123	14.375
	024	6.0	2.1	4.8	800	0.07	18.828	16.091
	030	7.5	3.0	7.0	1000	0.11	21.711	19.242
	036	9.0	1.6	3.8	1200	0.09	24.105	21.108
	042	10.5	2.3	5.2	1400	0.11	26.739	23.785
	048	12.0	1.8	4.2	1600	0.08	34.790	30.193
060	15.0	2.5	5.8	2000	0.14	39.031	35.758	
Horizontal	006	1.5	1.9	4.4	225	0.05	6.641	4.922
	009	2.3	3.2	7.3	300	0.07	8.288	6.631
	012	3.0	1.9	4.3	400	0.11	8.485	7.569
	015	3.8	2.9	6.6	500	0.05	15.118	11.905
	018	4.5	4.0	9.2	600	0.07	16.740	14.039
	024	6.0	1.2	2.8	800	0.08	19.110	16.294
	030	7.5	1.8	4.1	1000	0.12	22.209	19.672
	036	9.0	1.7	4.0	1200	0.11	25.142	21.717
	042	10.5	2.4	5.6	1400	0.14	27.879	24.488
	048	12.0	2.1	4.9	1600	0.10	37.671	31.675
060	15.0	3.0	6.9	2000	0.15	42.388	37.813	

Entering water 45 °F, Entering air DB 80 °F/WB 67 °F.

Physical Data Unit with WSE Option

TC Series	006	009	012	015	018	024	030	036	042	048	060
Water Connection Size FTP	1/2"	1/2"	1/2"	1/2"	1/2"	3/4"	3/4"	3/4"	3/4"	1"	1"
Vertical											
WSE Coil Dimensions (H x W)	10x15	10x15	10x15	20x17.25	20x17.25	20x17.25	20x17.25	24x21.75	24x21.76	24x28.25	24x28.25
WSE Coil Volume (Gal)	0.150	0.150	0.144	0.348	0.348	0.357	0.357	0.746	0.746	1.001	1.001
Weight - Operating (lbs.)	138	140	149	219	224	259	267	289	303	353	368
Weight - Packaged (lbs.)	148	150	159	224	229	264	272	295	310	360	375
Horizontal											
WSE Coil Dimensions (H x W)	10x15	10x15	10x15	16x22	16x22	16x22	16x22	20x25	20x25	20x35	20x35
WSE Coil Volume (Gal)	0.150	0.150	0.139	0.341	0.341	0.382	0.382	0.735	0.735	1.041	1.041
Weight - Operating (lbs.)	145	147	156	220	225	257	265	311	326	372	387
Weight - Packaged (lbs.)	155	157	166	225	230	262	270	317	332	379	394

ClimateMaster works continually to improve its products. As a result, the design and specifications of each product at the time of order may be changed without notice and may not be as described herein. Please contact ClimateMaster's Customer Service Department at 1-405-745-6000 for specific information on the current design and specifications. Statements and other information contained herein are not express warranties and do not form the basis of any bargain between the parties, but are merely ClimateMaster's opinion or commendation of its products. The latest version of this document is available at climatemaster.com. © ClimateMaster, Inc. All rights reserved 2009

Waterside Economizer Data

225 CFM Nominal Airflow – TC-006

EWT °F	Waterside			Capacity		
	FLOW (gpm)	PD (psi)	PD (ft)	TC	SC	LWT
45	0.8	1.0	2.4	5.051	4.125	58.5
45	1.1	1.4	3.3	5.965	4.627	55.6
45	1.5	1.9	4.4	6.641	4.922	53.9
50	0.8	1.0	2.4	4.297	3.578	61.5
50	1.1	1.4	3.2	4.956	4.064	58.8
50	1.5	1.9	4.3	5.420	4.345	57.2
55	0.8	1.0	2.4	3.640	2.950	64.7
55	1.1	1.4	3.2	4.112	3.418	62.3
55	1.5	1.9	4.3	4.425	3.682	60.9
60	0.8	1.0	2.4	3.045	2.230	68.1
60	1.1	1.4	3.2	3.400	2.676	66.0
60	1.5	1.9	4.3	3.619	2.926	64.8

300 CFM Nominal Airflow – TC-009

EWT °F	Waterside			Capacity		
	FLOW (gpm)	PD (psi)	PD (ft)	TC	SC	LWT
45	1.1	1.4	3.3	6.442	5.757	56.5
45	1.7	2.2	5.0	7.518	6.312	53.9
45	2.3	3.2	7.3	8.288	6.631	52.4
50	1.1	1.4	3.2	5.394	5.041	59.6
50	1.7	2.2	5.0	6.140	5.572	57.3
50	2.3	3.1	7.3	6.652	5.878	55.9
55	1.1	1.4	3.2	4.507	4.219	63.0
55	1.7	2.1	4.9	5.016	4.721	60.9
55	2.3	3.1	7.2	5.346	5.002	59.8
60	1.1	1.4	3.2	3.742	3.274	66.7
60	1.7	2.1	4.9	4.103	3.750	64.9
60	2.3	3.1	7.2	4.321	4.011	63.8

400 CFM Nominal Airflow – TC-012

EWT °F	Waterside			Capacity		
	FLOW (gpm)	PD (psi)	PD (ft)	TC	SC	LWT
45	1.5	0.7	1.5	6.898	6.590	54.2
45	2.3	1.2	2.8	7.820	7.189	52.0
45	3.0	1.9	4.3	8.485	7.569	50.7
50	1.5	0.6	1.5	5.843	5.771	57.8
50	2.3	1.2	2.7	6.410	6.232	55.7
50	3.0	1.9	4.3	6.784	6.509	54.5
55	1.5	0.6	1.4	4.937	4.927	61.6
55	2.3	1.2	2.7	5.369	5.344	59.8
55	3.0	1.8	4.3	5.611	5.568	58.7
60	1.5	0.6	1.4	3.892	3.874	65.2
60	2.3	1.2	2.7	4.326	4.314	63.8
60	3.0	1.8	4.2	4.558	4.548	63.0

500 CFM Nominal Airflow – TC-015

EWT °F	Waterside			Capacity		
	FLOW (gpm)	PD (psi)	PD (ft)	TC	SC	LWT
45	1.9	0.8	1.9	11.606	10.149	57.4
45	2.8	1.7	3.9	13.603	11.282	54.7
45	3.8	2.9	6.6	15.118	11.905	53.1
50	1.9	0.8	2.0	9.883	8.861	60.5
50	2.8	1.7	3.9	11.233	9.896	58.0
50	3.8	2.8	6.5	12.189	10.519	56.5
55	1.9	0.8	2.0	8.377	7.518	63.9
55	2.8	1.7	3.9	9.367	8.419	61.7
55	3.8	2.8	6.5	9.986	8.946	60.3
60	1.9	0.8	2.0	6.822	6.075	67.3
60	2.8	1.7	3.8	7.696	6.883	65.5
60	3.8	2.8	6.4	8.189	7.343	64.4

600 CFM Nominal Airflow – TC-018

EWT °F	Waterside			Capacity		
	FLOW (gpm)	PD (psi)	PD (ft)	TC	SC	LWT
45	2.3	1.1	2.7	12.933	12.189	56.5
45	3.4	2.4	5.4	15.110	13.404	54.0
45	4.5	4.0	9.2	16.740	14.039	52.4
50	2.3	1.1	2.7	10.918	10.653	59.7
50	3.4	2.3	5.4	12.351	11.788	57.3
50	4.5	3.9	9.1	13.359	12.462	55.9
55	2.3	1.1	2.6	9.223	9.052	63.2
55	3.4	2.3	5.4	10.225	10.028	61.1
55	4.5	3.9	9.0	10.854	10.597	59.8
60	2.3	1.1	2.6	7.543	7.346	66.7
60	3.4	2.3	5.3	8.400	8.216	65.0
60	4.5	3.8	8.9	8.880	8.705	63.9

800 CFM Nominal Airflow – TC-024

EWT °F	Waterside			Capacity		
	FLOW (gpm)	PD (psi)	PD (ft)	TC	SC	LWT
45	3.0	0.4	0.8	13.625	12.035	54.1
45	4.5	0.7	1.6	16.786	14.548	52.5
45	6.0	1.2	2.8	19.110	16.294	51.4
50	3.0	0.4	0.8	11.758	10.732	57.8
50	4.5	0.7	1.6	14.407	12.993	56.4
50	6.0	1.2	2.7	16.265	14.484	55.4
55	3.0	0.4	0.8	10.064	9.250	61.7
55	4.5	0.7	1.6	12.225	11.250	60.4
55	6.0	1.2	2.7	13.632	12.481	59.5
60	3.0	0.4	0.8	8.560	7.569	65.7
60	4.5	0.7	1.6	10.254	9.307	64.6
60	6.0	1.2	2.7	11.223	10.277	63.7

Interpolation is permissible, extrapolation is not. All entering air conditions are 80 °F DB and 67 °F WB. See performance correction tables for operating conditions other than those listed above.

Waterside Economizer Data

1000 CFM Nominal Airflow – TC-030

EWT °F	Waterside			Capacity		
	FLOW (gpm)	PD (psi)	PD (ft)	TC	SC	LWT
45	3.8	0.5	1.2	16.369	15.150	53.7
45	5.6	1.1	2.4	19.937	18.055	52.1
45	7.5	1.8	4.1	22.209	19.672	50.9
50	3.8	0.5	1.2	14.115	13.516	57.5
50	5.6	1.1	2.4	17.032	16.062	56.1
50	7.5	1.8	4.1	18.697	17.317	55.0
55	3.8	0.5	1.2	12.056	11.674	61.4
55	5.6	1.1	2.4	14.344	13.853	60.1
55	7.5	1.8	4.1	15.418	14.742	59.1
60	3.8	0.5	1.2	10.208	9.604	65.4
60	5.6	1.0	2.4	11.889	11.414	64.2
60	7.5	1.8	4.1	12.383	11.935	63.3

1200 CFM Nominal Airflow – TC-036

EWT °F	Waterside			Capacity		
	FLOW (gpm)	PD (psi)	PD (ft)	TC	SC	LWT
45	4.5	0.3	0.7	18.768	17.626	53.3
45	6.8	0.9	2.1	22.404	20.058	51.6
45	9.0	1.7	4.0	25.142	21.717	50.6
50	4.5	0.3	0.6	16.318	15.344	57.3
50	6.8	0.9	2.0	19.284	17.552	55.7
50	9.0	1.7	4.0	21.383	19.009	54.8
55	4.5	0.3	0.6	13.912	12.951	61.2
55	6.8	0.9	2.1	16.212	14.929	59.8
55	9.0	1.8	4.1	17.675	16.181	58.9
60	4.5	0.4	0.8	11.549	10.445	65.1
60	6.8	1.0	2.3	13.190	12.188	63.9
60	9.0	1.9	4.5	14.020	13.232	63.1

1400 CFM Nominal Airflow – TC-042

EWT °F	Waterside			Capacity		
	FLOW (gpm)	PD (psi)	PD (ft)	TC	SC	LWT
45	5.3	0.5	1.1	21.057	20.113	53.0
45	7.9	1.3	3.0	25.064	22.800	51.4
45	10.5	2.4	5.6	27.879	24.488	50.3
50	5.3	0.4	1.0	18.254	17.544	57.0
50	7.9	1.3	2.9	21.453	19.959	55.4
50	10.5	2.4	5.6	23.492	21.398	54.5
55	5.3	0.5	1.1	15.497	14.853	60.9
55	7.9	1.3	3.0	17.895	16.990	59.5
55	10.5	2.5	5.8	19.160	18.176	58.6
60	5.3	0.6	1.3	12.787	12.039	64.9
60	7.9	1.4	3.3	14.389	13.893	63.7
60	10.5	2.7	6.2	14.884	14.823	62.8

1600 CFM Nominal Airflow – TC-048

EWT °F	Waterside			Capacity		
	FLOW (gpm)	PD (psi)	PD (ft)	TC	SC	LWT
45	6.0	0.9	2.2	29.364	26.323	54.8
45	9.0	1.5	3.4	34.188	29.606	52.6
45	12.0	2.1	4.9	37.671	31.675	51.3
50	6.0	1.0	2.2	25.063	22.810	58.4
50	9.0	1.5	3.4	28.940	25.807	56.4
50	12.0	2.2	5.0	31.653	27.659	55.3
55	6.0	1.0	2.2	21.061	19.070	62.0
55	9.0	1.5	3.4	24.060	21.779	60.3
55	12.0	2.2	5.0	26.048	23.413	59.3
60	6.0	0.9	2.2	17.384	15.081	65.8
60	9.0	1.5	3.4	19.572	17.506	64.3
60	12.0	2.2	5.0	20.879	18.924	63.5

2000 CFM Nominal Airflow – TC-060

EWT °F	Waterside			Capacity		
	FLOW (gpm)	PD (psi)	PD (ft)	TC	SC	LWT
45	7.5	1.2	2.7	33.525	32.134	53.9
45	11.3	1.9	4.5	38.794	35.768	51.9
45	15.0	3.0	6.9	42.388	37.813	50.7
50	7.5	1.2	2.8	28.521	27.934	57.6
50	11.3	2.0	4.6	32.687	31.220	55.8
50	15.0	3.0	6.9	35.360	32.993	54.7
55	7.5	1.2	2.8	23.862	23.471	61.4
55	11.3	2.0	4.6	26.996	26.408	59.8
55	15.0	3.0	7.0	28.793	27.909	58.8
60	7.5	1.2	2.7	19.574	18.723	65.2
60	11.3	2.0	4.6	21.744	21.316	63.9
60	15.0	3.0	7.0	22.709	22.548	63.0

PD Table for WSE 3 Way Valve

Model	Econ - On	Econ -Off
	CV	
006	5.6	4.9
009	5.6	4.9
012	5.6	4.9
015	11.7	5.8
018	11.7	5.8
024	11.7	5.8
030	11.7	5.8
036	11.7	5.8
042	11.7	5.8
048	18.7	9.3
060	18.7	9.3

Interpolation is permissible, extrapolation is not. All entering air conditions are 80 °F DB and 67 °F WB. See performance correction tables for operating conditions other than those listed above.

Airside PD

		AirSide PD Adder (in. wg) at CFM				
Model	Rated Airflow	150	175	200	225	250
TC*006	225	0.03	0.03	0.04	0.05	0.06
Model	Rated Airflow	225	260	300	340	375
TC*009	300	0.05	0.06	0.07	0.09	0.10
Model	Rated Airflow	300	350	400	450	500
TC*012	400	0.07	0.09	0.11	0.13	0.15
Model	Rated Airflow	375	437.5	500	562.5	625
TC*015	500	0.03	0.04	0.05	0.06	0.07
Model	Rated Airflow	450	525	600	675	750
TC*018	600	0.04	0.06	0.07	0.08	0.10
Model	Rated Airflow	600	700	800	900	1000
TC*024	800	0.05	0.07	0.08	0.10	0.12
Model	Rated Airflow	750	875	1000	1125	1250
TC*030	1000	0.08	0.10	0.12	0.14	0.16
Model	Rated Airflow	900	1050	1200	1350	1500
TC*036	1200	0.07	0.09	0.11	0.13	0.16
Model	Rated Airflow	1050	1225	1400	1575	1750
TC*042	1400	0.09	0.12	0.14	0.17	0.21
Model	Rated Airflow	1200	1400	1600	1800	2000
TC*048	1600	0.06	0.08	0.10	0.12	0.15
Model	Rated Airflow	1500	1750	2000	2250	2500
TC*060	2000	0.09	0.12	0.15	0.17	0.20

Add WSE to your duct static to get total ESP. Check blower performance table to be sure you meet CFM requirement and are within operational range.

Waterside Economizer Correction Tables

Entering Air Correction Table for WSE

Full Load Cooling Corrections 400 CFM per Ton										
Ent Air WB °F	Total Clg Cap	Sens Clg Cap Multipliers - Entering DB °F								
		65	70	75	80	80.6	85	90	95	100
50	0.352	*	*	*	*	*	*	*	*	*
55	0.507	0.615	0.766	*	*	*	*	*	*	*
60	0.693	0.542	0.740	0.912	*	*	*	*	*	*
65	0.906		0.623	0.842	1.035	1.057	*	*	*	*
66.2	0.962		0.582	0.811	1.016	1.039	1.195	*	*	*
67	1.000		0.551	0.788	1.000	1.024	1.187	*	*	*
70	1.148			0.681	0.920	0.947	1.135	1.324	*	*
75	1.420				0.715	0.748	0.976	1.211	1.421	1.421

* Sensible capacity equals total capacity.
 AHRI/ISO/ASHRAE 13256-1 uses entering air conditions of Cooling - 80.6°F DB/ 66.2°F WB, and Heating - 68°F DB/ 59°F WB entering air temperature.

Airflow Correction Table

Airflow	Cooling Corrections	
% Normal Capacity	Sensible Capacity	Sens/ Total Ratio
75	0.834	0.940
81.25	0.878	0.957
87.5	0.921	0.972
93.75	0.962	0.987
100	1.000	1.000
106.25	1.036	1.012
112.5	1.071	1.023
118.75	1.103	1.033
125	1.133	1.042

Physical Data

TC Series	006	009	012	015	018	024	030	036	041	042	048	060
Compressor (1 Each)	Rotary					Scroll						
Factory Charge HFC-410A (oz)	19	20	23	35	43	40	48	50	70	70	74	82
ECM Fan Motor & Blower												
Blower Wheel Size (Dia x w)	6x5	6x5	6x5	9x7	9x7	9x7	9x7	9x8	N/A	9x8	10x10	12x10
PSC Fan Motor & Blower												
Fan Motor Type/Speeds	PSC/3	PSC/3	PSC-3	PSC/3	PSC/3	PSC/3	PSC/3	PSC/3	PSC/3	PSC/3	PSC/3	PSC/3
Blower Wheel Size (Dia x w)	5x5	5x5	6x5	8x7	8x7	9x7	9x7	9x8	9x8	9x8	10x10	12x10
Water Connection Size												
FPT	1/2"	1/2"	1/2"	1/2"	1/2"	3/4"	3/4"	3/4"	3/4"	3/4"	1"	1"
Coax Volume (gallons)	0.123	0.143	0.167	0.286	0.450	0.286	0.323	0.323	0.890	0.890	0.738	0.939
Vertical												
Air Coil Dimensions (H x W)	10x15	10x15	10x15	20x17.25	20x17.25	20x17.25	20x17.25	24x21.75	20x17.25	24x21.76	24x28.25	24x28.25
Filter Standard - 1" Throwaway	10x18	10x18	10x18	20x20	20x20	20x20	20x20	24x24	20x20	24x24	1-14x24, 1-18x24	1-14x24, 1-18x24
Weight - Operating (lbs.)	103	105	114	153	158	189	197	203	210	218	263	278
Weight - Packaged (lbs.)	113	115	124	158	163	194	202	209	217	224	270	285
Horizontal												
Air Coil Dimensions (H x W)	10x15	10x15	10x15	16x22	16x22	16x22	16x22	20x25	N/A	20x25	20x35	20x35
Filter Standard - 1" Throwaway	10x18	10x18	10x18	16x25	16x25	18x25	18x25	20x28 or 2-20x14	N/A	20x28 or 2-20x14	1-20x24, 1-20x14	1-20x24, 1-20x14
Weight - Operating (lbs.)	103	105	114	153	158	174	182	203	N/A	218	263	278
Weight - Packaged (lbs.)	113	115	124	158	163	179	187	209	N/A	224	270	285

Notes:

All units have TXV expansion device, and 1/2" & 3/4" electrical knockouts.

FPT = Female Pipe Thread

Condensate Drain Connection is rubber coupling that couples to 3/4" schedule 40/80 PVC.

575 volt fan motors are two speed.

Unit Maximum Water Working Pressure	Max Pressure PSIG [kPa]
Base Unit	500 [3447]
WSE Option	300 [2068]

Use the lowest maximum pressure rating that applies to your unit.

TC: Horizontal – Dimensional Data

Horizontal Model		Overall Cabinet		
		A Width	B Length	C Height
006 - 012	in cm	19.1 48.5	34.1 86.6	11.1 28.2
015 - 018	in cm	20.1 51.1	43.1 109.5	17.0 43.2
024 - 030	in cm	20.1 51.1	43.1 109.5	18.3 46.5
036 - 042	in cm	20.1 51.1	47.1 119.6	21.0 53.3
048 - 060	in cm	24.1 61.2	54.1 137.4	21.0 53.3

Horizontal Model		Electrical Knockouts	
		J 1/2"	K 3/4"
		Low Voltage	Power Supply
006 - 012	in cm	5.1 13.0	2.1 5.4
015 - 018	in cm	9.9 25.2	6.9 17.5
024 - 030	in cm	11.1 28.2	8.1 20.6
036 - 060	in cm	13.9 35.3	10.9 27.7

Horizontal Model		Water Connections						Loop In/Out FPT
		①		②		③		
		Loop In D	Loop In E	Loop Out F	Loop Out G	AA	BB	
006 - 012	in cm	5.6 14.2	1.1 2.7	1.6 4.1	1.1 2.7	3.3 8.4	0.7 1.8	1/2"
015	in cm	15.1 38.4	1.4 3.4	3.2 8.1	1.4 3.5	3.3 8.4	0.7 1.8	1/2"
018	in cm	15.1 38.4	1.4 3.4	4.1 10.4	1.4 3.5	3.3 8.4	0.7 1.8	1/2"
024	in cm	16.4 41.7	1.4 3.4	4.4 11.3	1.4 3.5	3.3 8.4	0.7 1.8	3/4"
030	in cm	16.4 41.7	1.4 3.4	3.1 7.8	1.4 3.5	3.3 8.4	0.7 1.8	3/4"
036	in cm	19.1 48.5	1.4 3.4	5.3 13.4	1.4 3.5	3.3 8.4	0.7 1.8	3/4"
042	in cm	19.1 48.5	1.4 3.4	4.4 11.3	1.4 3.5	3.3 8.4	0.7 1.8	3/4"
048	in cm	19.1 48.5	1.4 3.4	4.4 11.1	1.4 3.5	3.3 8.4	0.7 1.8	1"
060	in cm	19.1 48.5	1.4 3.4	3.8 9.7	1.4 3.5	3.3 8.4	0.7 1.8	1"

Horizontal Model		Discharge Connection Duct Flange Installed (+/- 0.10 in, +/- 2.5mm)					Return Connection Using Return Air Opening			
		L	M Supply Height	N Supply Width	O	P	Q Return Width	R Return Height	S	T
006 - 012	in cm	0.8 1.9	8.9 22.7	6.7 17.0	6.0 15.2	1.3 3.3	16.1 41.0	9.8 25.0	1.1 2.7	0.6 1.5
015 - 018	in cm	2.6 6.6	13.3 33.8	9.9 25.1	4.1 10.5	1.3 3.3	23.0 58.4	15.0 38.1	1.1 2.8	1.0 2.5
024 - 030	in cm	2.6 6.6	13.3 33.8	9.9 25.1	4.1 10.5	1.3 3.3	23.0 58.4	16.3 41.4	1.1 2.8	1.0 2.5
036 - 042	in cm	2.5 6.3	16.1 40.9	11.0 27.9	3.0 7.7	2.5 6.4	25.9 65.8	19.0 48.3	1.1 2.8	1.0 2.5
048	in cm	3.7 9.5	16.1 41.0	13.7 34.8	4.1 10.3	1.3 3.2	35.9 91.2	19.0 48.3	1.1 2.8	1.0 2.5
060	in cm	1.7 4.4	18.1 46.0	13.7 34.8	4.1 10.3	1.3 3.2	35.9 91.2	19.0 48.3	1.1 2.8	1.0 2.5

ClimateMaster works continually to improve its products. As a result, the design and specifications of each product at the time of order may be changed without notice and may not be as described herein. Please contact ClimateMaster's Customer Service Department at 1-405-745-6000 for specific information on the current design and specifications. Statements and other information contained herein are not express warranties and do not form the basis of any bargain between the parties, but are merely ClimateMaster's opinion or commendation of its products. The latest version of this document is available at climatemaster.com. © ClimateMaster, Inc. All rights reserved 2009

TC: Horizontal – Dimensional Data

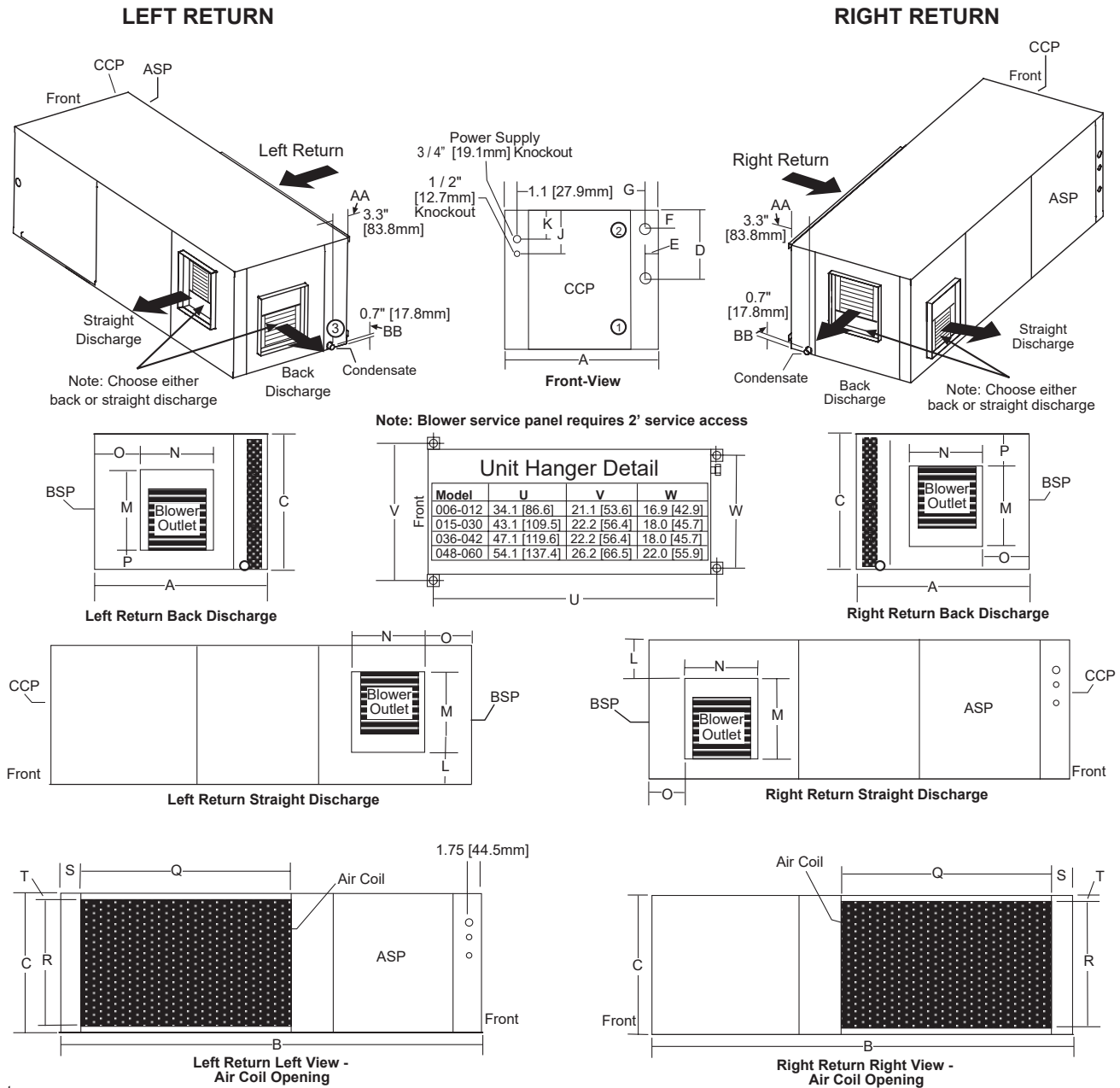

Notes:

1. While clear access to all removable panels is not required, installer should take care to comply with all building codes and allow adequate clearance for future field service.
2. Units are shipped with either filter rails or filter frames depending on unit model. Air filter rails are not suitable for supporting return air duct. Air filter frames are provided with a duct mounting collar for connection to return air duct.
3. Discharge flange and hanger brackets are factory installed.
4. Condensate fitting on Polymer drain pan is rubber coupling that couples to 3/4" schedule 40/80 PVC, S.S. drain pan is 3/4" MPT.
5. Blower service panel requires 2' service access.
6. Blower service access is through back panel on straight discharge units or through panel opposite air coil on back discharge units.

Legend:

CCP = Control/Compressor Access Panel.

BSP = Blower Service Panel.

*ASP = Additional Service Panel (not required).

Note:

*ASP are removable panels that provide additional access to the units interior.

Clear access to ASP panels is not required and they are not to be used in place of the mandatory CCP and BSP panels.

TCH with Left Hand Waterside Economizer – Dimensional Data

Horizontal Model		Overall Cabinet			WSE	Left WSE Connections							Return Connection Using Return Air Opening				
		A Width	B Length	C Height		H Width	In		Out		Cond. 3/4" MPT		Water In/Out FPT	Q Return Width	R Return Height	S	T
							D	E	F	G	AA	BB					
006-012	in	26.1	34.1	11.0	7.1	4.7	3.5	8.0	3.5	3.5	0.8	1/2"	16.1	10.0	1.5	0.3	
	cm	66.3	86.6	27.9	18.0	11.9	8.9	20.3	8.9	8.9	2.0		40.9	25.4	3.8	0.8	
015-018	in	27.2	43.1	17.0	7.1	5.3	3.5	11.5	3.5	3.5	0.8	1/2"	23.0	16.0	1.5	0.3	
	cm	69.1	109.5	43.2	18.0	13.5	8.9	29.2	8.9	8.9	2.0		58.4	40.6	3.8	0.8	
024-030	in	27.2	43.1	18.2	7.1	5.1	3.5	21.1	3.5	3.5	0.8	3/4"	22.9	16.0	1.5	0.3	
	cm	69.1	109.5	46.2	18.0	13.0	8.9	53.6	8.9	8.9	2.0		58.2	40.6	3.8	0.8	
036-042	in	27.2	47.1	21.0	7.1	6.5	3.5	14.0	3.5	3.5	0.8	3/4"	26.0	20.0	1.5	0.3	
	cm	69.1	119.6	53.3	18.0	16.5	8.9	35.6	8.9	8.9	2.0		66.0	50.8	3.8	0.8	
048-060	in	31.6	54.1	21.0	7.5	5.0	1.3	15.9	1.3	3.5	0.8	3/4"	36.0	20.0	1.5	0.3	
	cm	80.3	137.4	53.3	19.1	12.7	3.3	40.4	3.3	8.9	2.0		91.4	50.8	3.8	0.8	

Left Return with WSE

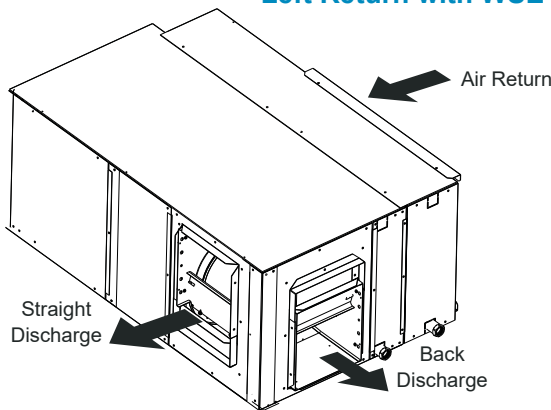

Unit Hanger Detail

Model	U	V	W
006-012	34.1 [86.6]	21.1 [53.6]	16.9 [42.9]
015-030	43.1 [109.5]	22.2 [56.4]	18.0 [45.7]
036-042	47.1 [119.6]	22.2 [56.4]	18.0 [45.7]
048-060	54.1 [137.4]	26.2 [66.5]	22.0 [55.9]

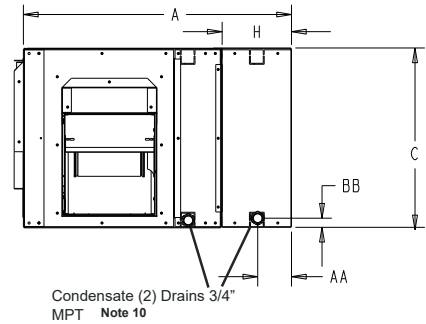
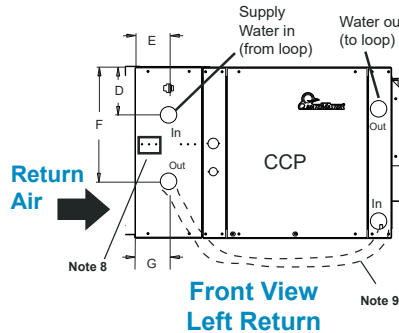
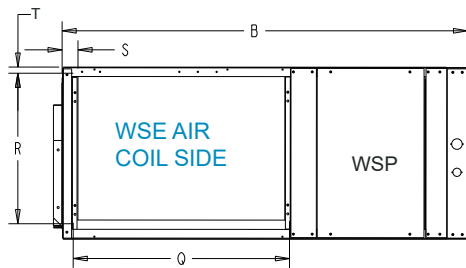

Back View

Notes:

- While clear access to all removable panels is not required, installer should take care to comply with all building codes and allow adequate clearance for future field service.
- Units are shipped with either filter rails or filter frames depending on unit model. Air filter rails are not suitable for supporting return air duct. Air filter frames are provided with a duct mounting collar for connection to return air duct.
- Discharge flange and hanger brackets are factory installed.
- Condensate drains are 3/4" MPT.
- Blower service panel requires 2' service access.
- Blower service access is through back panel on straight discharge units or through panel opposite air coil on back discharge units.
- Filters same size as standard unit.
- Factory supplied controller (aquastat) is shipped inside unit. Open waterside economizer panel (WSP), remove, slide onto dinrail, and connect moxex.
- WSE to unit piping to be field fabricated, Run below or in front. Must leave room to remove front access panel (CCP) to service unit.
- External trap and vent both drains before joining.
- Refer to Discharge Air connection dimensions.

TCH with Right Hand Waterside Economizer – Dimensional Data

Horizontal Model		Overall Cabinet			WSE	Left WSE Connections							Return Connection Using Return Air Opening				
		A Width	B Length	C Height		H Width	In		Out		Cond. 3/4" MPT		Water In/Out FPT	Q Return Width	R Return Height	S	T
							D	E	F	G	AA	BB					
006-012	in	26.1	34.1	11.0	7.1	8.0	3.5	4.7	3.5	3.5	0.8	1/2"	16.1	10.0	1.5	0.3	
	cm	66.3	86.6	27.9	18.0	20.3	8.9	11.9	8.9	8.9	2.0		40.9	25.4	3.8	0.8	
015-018	in	27.2	43.1	17.0	7.1	11.5	3.5	5.3	3.5	3.5	0.8	1/2"	23.0	16.0	1.5	0.3	
	cm	69.1	109.5	43.2	18.0	29.2	8.9	13.5	8.9	8.9	2.0		58.4	40.6	3.8	0.8	
024-030	in	27.2	43.1	18.2	7.1	21.1	3.5	5.1	3.5	3.5	0.8	3/4"	22.9	16.0	1.5	0.3	
	cm	69.1	109.5	46.2	18.0	53.6	8.9	13.0	8.9	8.9	2.0		58.2	40.6	3.8	0.8	
036-042	in	27.2	47.1	21.0	7.1	14.0	3.5	6.5	3.5	3.5	0.8	3/4"	26.0	20.0	1.5	0.3	
	cm	69.1	119.6	53.3	18.0	35.6	8.9	16.5	8.9	8.9	2.0		66.0	50.8	3.8	0.8	
048-060	in	31.6	54.1	21.0	7.5	15.9	1.3	5.0	1.3	3.5	0.8	3/4"	36.0	20.0	1.5	0.3	
	cm	80.3	137.4	53.3	19.1	40.4	3.3	12.7	3.3	8.9	2.0		91.4	50.8	3.8	0.8	

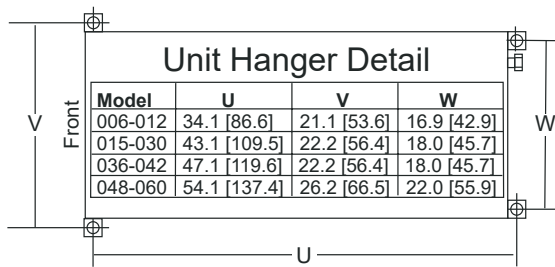

Right Return with WSE

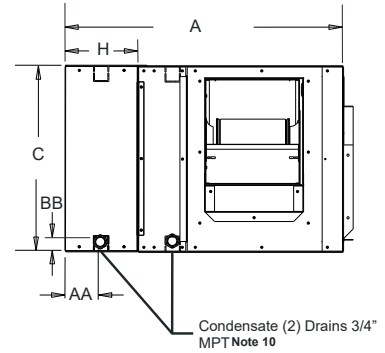
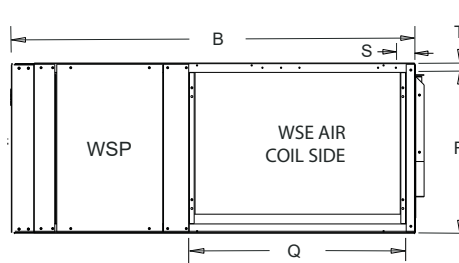
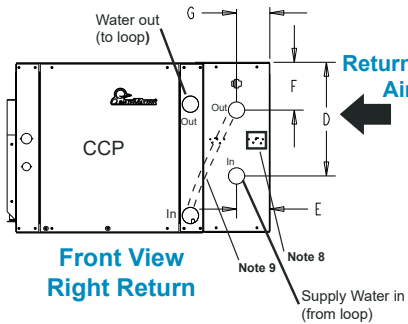
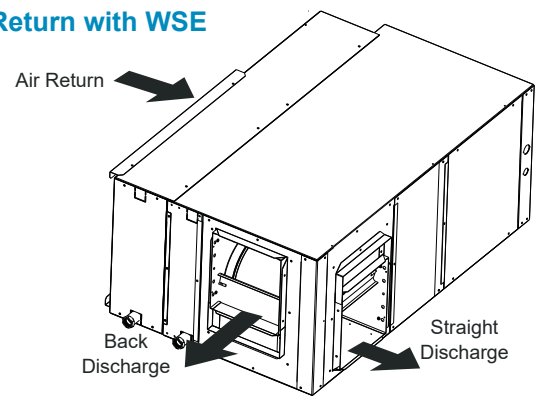

Back View

Notes:

- While clear access to all removable panels is not required, installer should take care to comply with all building codes and allow adequate clearance for future field service.
- Units are shipped with either filter rails or filter frames depending on unit model. Air filter rails are not suitable for supporting return air duct. Air filter frames are provided with a duct mounting collar for connection to return air duct.
- Discharge flange and hanger brackets are factory installed.
- Condensate drains are 3/4" MPT.
- Blower service panel requires 2' service access.
- Blower service access is through back panel on straight discharge units or through panel opposite air coil on back discharge units.
- Filters same size as standard unit.
- Factory supplied controller (aquastat) is shipped inside unit. Open waterside economizer panel (WSP), remove, slide onto dinrail, and connect molex.
- WSE to unit piping to be field fabricated. Run below or in front. Must leave room to remove front access panel (CCP) to service unit.
- External trap and vent both drains before joining.
- Refer to Discharge Air connection dimensions.

TC: Horizontal Service Access

Left Return Back Discharge

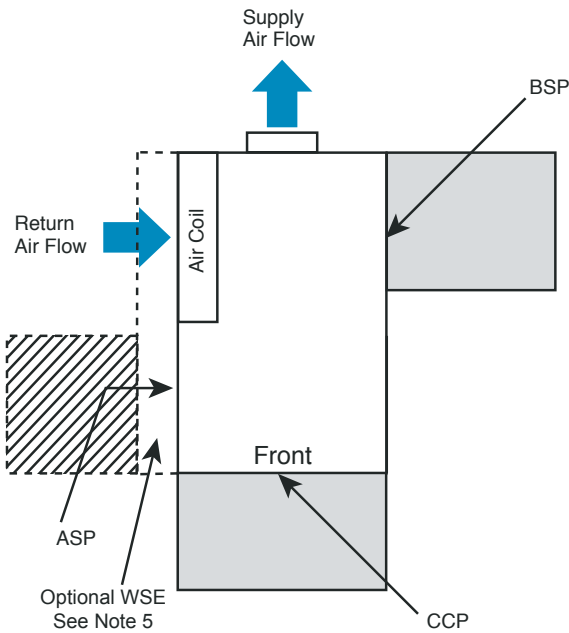

Right Return Back Discharge

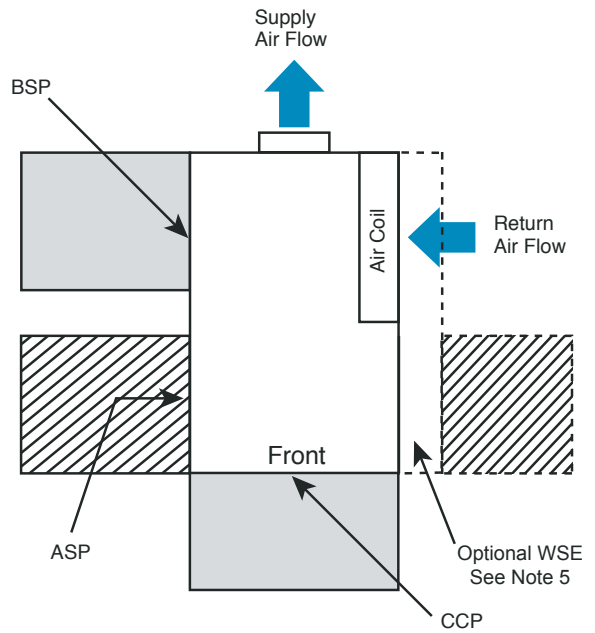

Left Return Straight Discharge

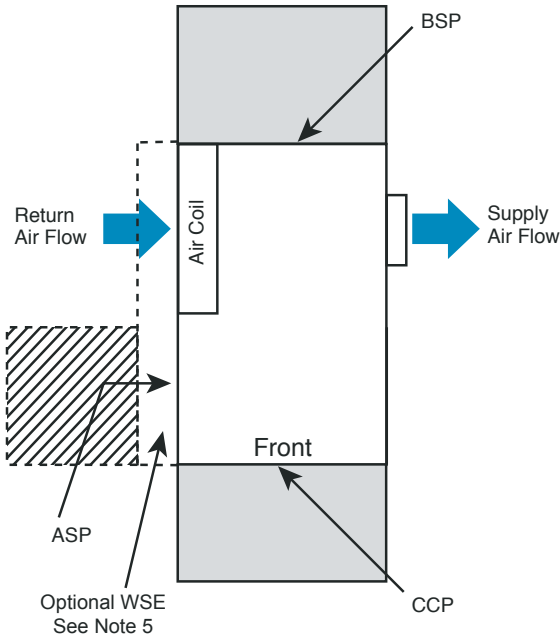

Right Return Straight Discharge

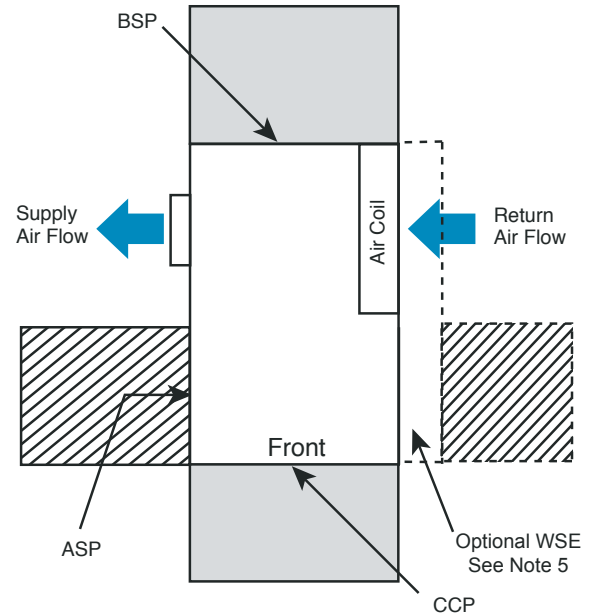

Notes:

1. While clear access to all removable panels is not required, installer should take care to comply with all building codes and allow adequate clearance for future field service.
2. CCP and BSP requires 2' service access.
3. Blower service access is through back panel on straight discharge units or through panel opposite air coil on back discharge units.
4. ASP are removable panels that provide additional access to the units interior. Clear access to ASP panels is not required and they are not to be used in place of the mandatory CCP and BSP panels.
5. Units with WSE must have access to water valve through side access panel.

■ = mandatory 2' service access

▨ = (optional) additional 2' service access

Legend:

CCP = Control/Compressor Access Panel
 BSP = Blower Service Panel
 ASP = Additional Service Panel (not required)
 WSE = Waterside Economizer

ClimateMaster works continually to improve its products. As a result, the design and specifications of each product at the time of order may be changed without notice and may not be as described herein. Please contact ClimateMaster's Customer Service Department at 1-405-745-6000 for specific information on the current design and specifications. Statements and other information contained herein are not express warranties and do not form the basis of any bargain between the parties, but are merely ClimateMaster's opinion or commendation of its products. The latest version of this document is available at climatemaster.com. © ClimateMaster, Inc. All rights reserved 2009

TC: Vertical Upflow – Dimensional Data

Vertical Upflow Model		Overall Cabinet		
		A Width	B Depth	C Height
006 - 012	in cm	19.1 48.5	19.1 48.5	22.0 55.9
015 - 030, 041	in cm	21.5 54.6	21.5 54.6	40.0 101.6
036 - 042	in cm	21.5 54.6	26.0 66.0	45.0 114.3
048 - 060	in cm	24.0 61.0	32.5 82.6	46.0 116.8

Vertical Model		Electrical Knockouts	
		J 1/2"	K 3/4"
		Low Voltage	Power Supply
006 - 012	in cm	5.9 14.9	8.9 22.5
015 - 060	in cm	7.1 18.1	10.1 25.7
041	in cm	7.1 18.0	11.1 28.2

Vertical Upflow Model		Water Connections - Standard Units						
		①		②		③		Loop In/Out FPT
		Loop In D	Loop In E	Loop Out F	Loop Out G	H	I	
006 - 012	in cm	1.5 3.8	1.5 3.8	9.5 24.1	1.5 3.8	11.7 29.7	1.4 3.6	1/2"
015	in cm	1.9 4.8	1.4 3.6	13.8 35.1	1.4 3.6	19.7 50.0	1.4 3.6	1/2"
018	in cm	1.9 4.8	1.4 3.6	13.8 35.1	1.4 3.6	19.7 50.0	1.4 3.6	1/2"
024	in cm	1.9 4.8	1.4 3.6	13.8 35.1	1.4 3.6	19.7 50.0	1.4 3.6	3/4"
030	in cm	1.9 4.8	1.4 3.6	15.2 38.6	1.4 3.6	19.7 50.0	1.4 3.6	3/4"
036	in cm	1.9 4.8	1.4 3.6	15.2 38.6	1.4 3.6	20.6 52.3	1.4 3.6	3/4"
041	in cm	3.6 4.8	2.3 5.8	14.0 35.6	2.3 5.8	18.3 46.5	2.3 5.8	3/4"
042	in cm	1.9 4.8	1.4 3.6	16.6 42.0	1.4 3.6	20.6 52.3	1.4 3.6	3/4"
048	in cm	2.0 5.1	1.4 3.6	16.9 42.9	1.4 3.6	21.6 54.9	1.4 3.6	1"
060	in cm	2.0 5.1	1.4 3.6	17.4 44.2	1.4 3.6	21.6 54.9	1.4 3.6	1"

Notes:

- While clear access to all removable panels is not required, installer should take care to comply with all building codes and allow adequate clearance for future field service.
- Front & Side access is preferred for service access. However, all components may be serviced from the front access panel if side access is not available. (Except on TCV 009-030 and 041 with front return) Units with the front return require left side access for the fan.
- Discharge flange is field installed.
- Condensate fitting on Polymer drain pan is rubber coupling that couples to 3/4" schedule 40/80 PVC, S.S. drain pan is 3/4" MPT.
- Units are shipped with air filter rails that are not suitable for supporting return air ductwork. An air filter frame with duct mounting collar is available as an accessory, see the ClimateMaster Accessory Submittal set for further information on this frame.

Legend:

- CCP = Control/Compressor Access Panel
- BSP = Blower Service Panel
- ASP = Alternative Service Panel

Recommended Minimum Installation Clearances for Vertical Units*	
1"	Back of unit
	Side opposite return air
6"	Front if hard piped
Return Air Side	
1"	Ducted return
	- ± *Add for duct width
	- † Add 2" for 1" filter frame/rail or 3" for 2" filter frame/rail
	Free (open) return - calculate required dimension for a maximum velocity of 600 fpm

* Field installed accessories (hoses, air cleaners, etc.) and factory WSE option will require additional space. Top supply air is shown, the same clearances apply to bottom supply air units.

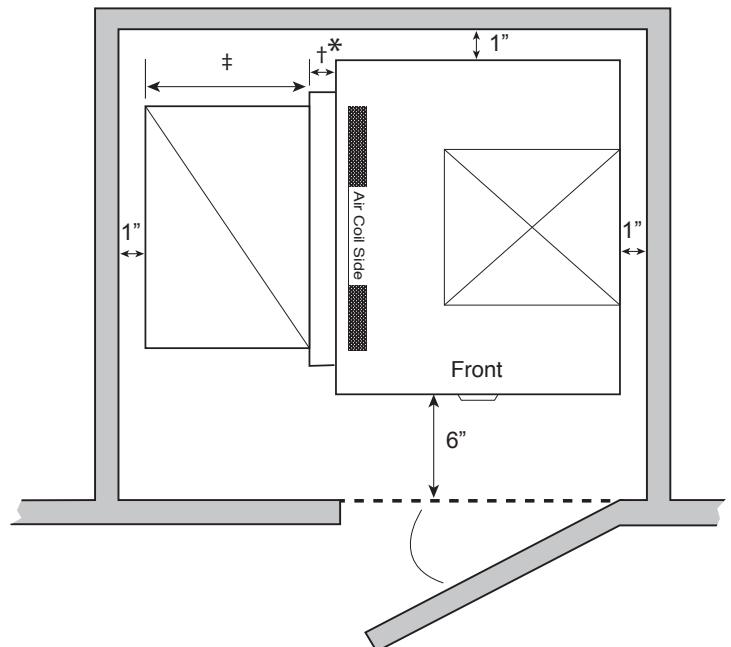

TC: Vertical Upflow – Dimensional Data

Vertical Model		Discharge Connection Duct Flange Installed (+/- 0.10 in, +/- 2.5mm)				Return Connection Using Return Air Opening				
		M	N	O Supply Width	P Supply Depth	Q	R	S Return Depth	T Return Height	U
006 - 012	in	8.9	5.1	9.0	9.0	5.5	2.1	16.2	9.9	0.7
	cm	22.7	12.9	22.9	22.9	14.0	5.3	41.1	25.1	1.9
015 - 018	in	6.4	3.8	14.0	14.0	5.3	2.3	18.3	20.9	0.7
	cm	16.1	9.5	35.6	35.6	13.6	5.8	46.5	53.1	1.9
024 - 030	in	6.4	5.0	14.0	14.0	5.8	2.0	18.5	19.3	0.9
	cm	16.3	12.7	35.6	35.6	14.7	5.1	47.0	49.0	2.3
036 - 042	in	6.4	3.8	14.0	14.0	5.1	2.3	22.8	23.9	0.7
	cm	16.1	9.5	35.6	35.6	13.1	5.8	57.9	60.7	1.9
048 - 060	in	6.9	7.3	16.0	18.0	5.1	2.3	29.3	22.5	0.7
	cm	17.4	18.4	40.6	45.7	13.1	5.8	74.4	57.0	1.9

Front Return - N = 4.8 in (12.2 cm), Q = 6.4 in (16.3 cm).
 Right Return - N = 3.8 in (9.7 cm), Q = 5.5 in (14.0 cm).
 Left Return - M = 6.4 in (16.3 cm), N = 2.8 in (7.1 cm).

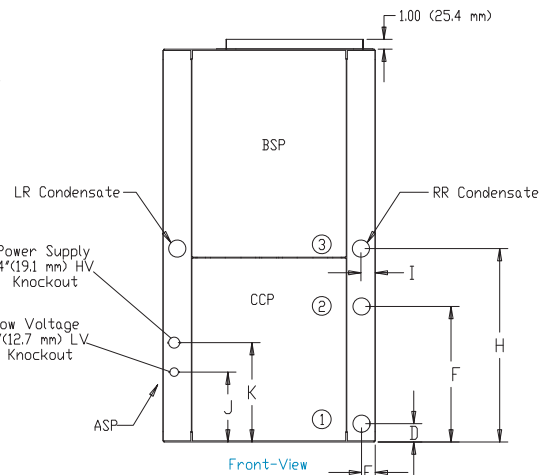
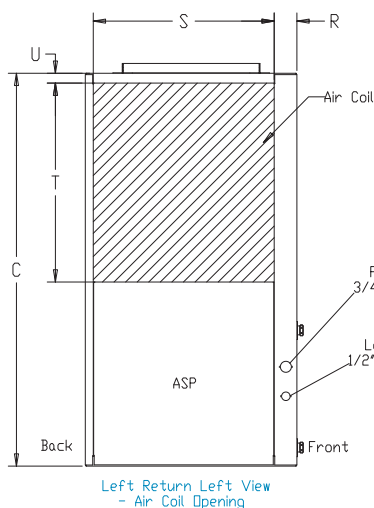
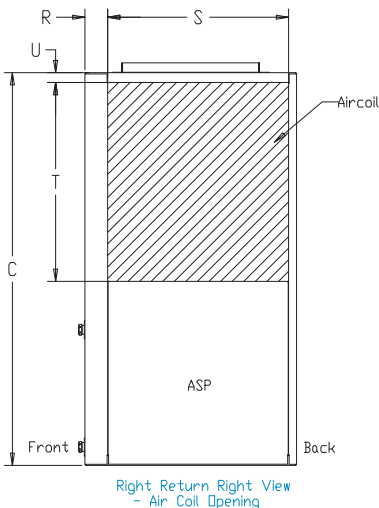
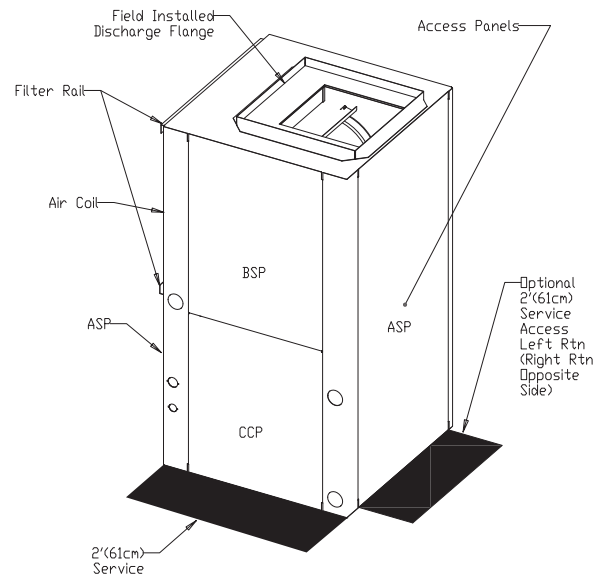
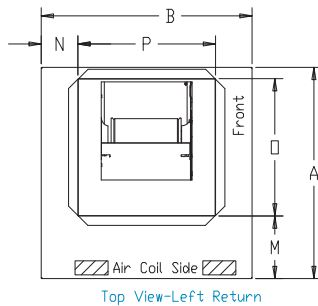
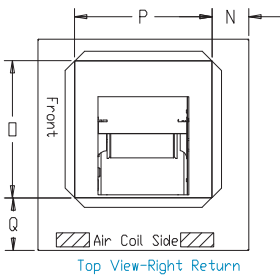
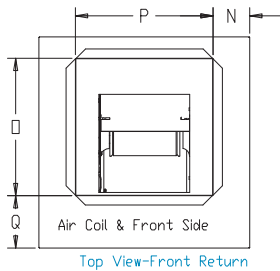

Units are shipped with either filter rails or filter frames depending on unit model. Air filter rails are not suitable for supporting return air duct. Air filter frames are provided with a duct mounting collar for connection to return air duct.

TC: Front Return Vertical Upflow – Dimensional Data

Vertical Model	Overall Cabinet			Water Connection - Front Return Units			Top Discharge Connection Duct Flange Installed (+/- 0.10 in, +/- 2.5mm)				
	A Width	B Depth	C Height	D Water In	F Water Out	H Cond. Drain	N	O Supply Width	P Supply Depth	Q	
009 - 012	in	19.1	19.0	22.0	1.6	9.6	11.5	5.1	9.0	9.0	6.0
	cm	48.5	48.3	55.9	4.1	24.4	29.2	12.9	22.9	22.9	15.2
015 - 018	in	21.6	21.5	40.0	1.9	13.8	19.7	3.8	14.0	14.0	5.4
	cm	54.9	54.6	101.6	4.8	35.1	50.0	9.5	35.6	35.6	13.7
024	in	21.6	21.5	40.0	1.9	13.8	19.7	3.8	14.0	14.0	5.4
	cm	54.9	54.6	101.6	4.8	35.1	50.0	12.7	35.6	35.6	14.7
030	in	21.6	21.5	40.0	1.9	15.2	19.7	3.8	14.0	14.0	5.4
	cm	54.9	54.6	101.6	4.8	38.6	50.0	12.7	35.6	35.6	14.7
041	in	21.6	21.6	39.0	3.6	14.0	18.3	4.8	14.0	14.0	6.4
	cm	54.9	54.9	99.1	9.1	35.6	46.5	9.5	35.6	35.6	13.0

* For Air Coil and Filter Dimensions see the physical data table.
See electrical knockout table for details on low and high voltage power connection dimensions.

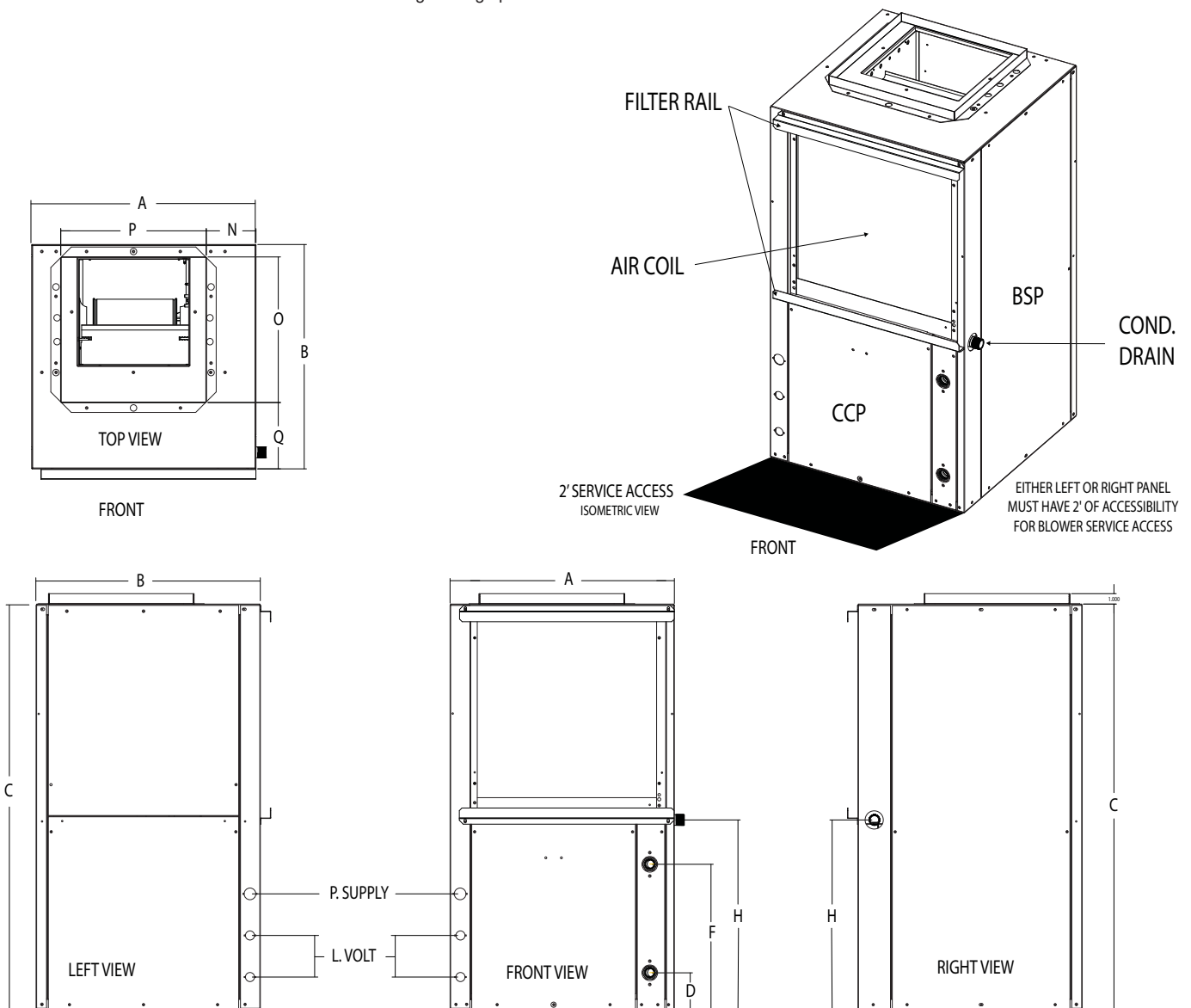

Units are shipped with either filter rails or filter frames depending on unit model. Air filter rails are not suitable for supporting return air duct. Air filter frames are provided with a duct mounting collar for connection to return air duct.

TCV with Left Hand Waterside Economizer – Dimensional Data

Vertical Model		Overall Cabinet			WSE	WSE Connections							Return Connection Using Return Air Opening				
		A Width	B Length	C Height		H Width	In		Out		Cond. 3/4" MPT		Water In/Out FPT	Q Return Width	R Return Height	S	T
							D	E	F	G	AA	BB					
006-012	in	26.1	21.2	22.0	7.1	8.1	5.5	2.1	5.5	5.1	5.5	1/2"	16.1	10.0	4.2	0.4	
	cm	66.3	53.8	55.9	18.0	20.6	14.0	5.3	14.0	13.0	14.0		40.9	25.4	10.7	1.0	
015-030	in	29.0	24.7	40.0	7.4	11.6	6.0	2.6	6.0	7.1	6.0	3/4"	18.1	20.0	3.8	0.3	
	cm	73.7	62.7	101.6	18.8	29.5	15.2	6.6	15.2	18.0	15.2		46.0	50.8	9.7	0.8	
036-042	in	29.0	28.7	45.0	7.4	12.1	6.0	2.6	6.0	7.1	6.0	3/4"	22.7	24.0	4.6	0.1	
	cm	73.7	72.9	114.3	18.8	29.5	15.2	6.6	15.2	18.0	15.2		57.7	61.0	11.7	0.3	
048-060	in	31.2	37.2	46.0	7.0	12.1	5.8	3.1	5.8	7.1	5.8	3/4"	29.3	24.0	5.0	0.1	
	cm	79.2	94.5	116.8	17.8	30.7	14.7	7.9	14.7	18.0	14.7		74.4	61.0	12.7	0.3	

Left Return with WSE

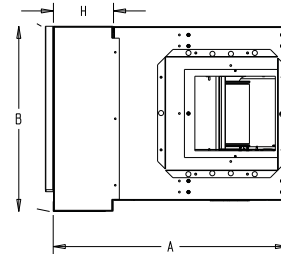
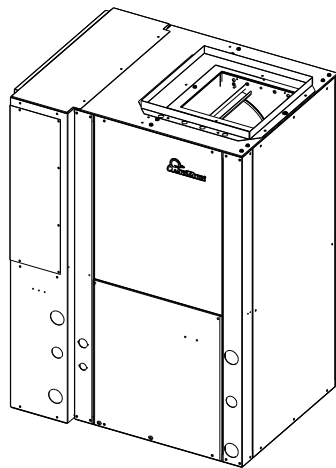

Top View

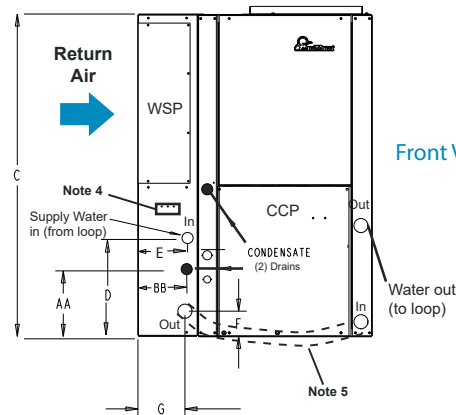
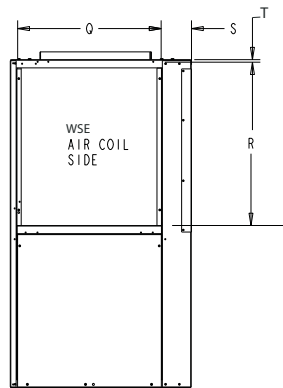

Front View Left Return

Notes:

- Units are shipped with either filter rails or filter frames depending on unit model. Air filter rails are not suitable for supporting return air duct. Air filter frames are provided with a duct mounting collar for connection to return air duct.
- WSE condensate drain is 3/4" FPT, Unit condensate drain is 3/4" MPT. Externally trap and vent both drains before joining.
- Filters same size as standard unit.
- Factory supplied controller (aquastat) is shipped inside unit. Open waterside economizer panel (WSP), remove, slide onto dinrail, and connect molex.
- WSE to unit piping to be field fabricated, run below or in front. Must leave room to remove front access panel (CCP) to service unit.
- Refer to Discharge Air connection dimensions.

TCV with Right Hand Waterside Economizer – Dimensional Data

Vertical Model		Overall Cabinet			WSE	WSE Connections						Return Connection Using Return Air Opening				
		A Width	B Length	C Height	H Width	In		Out		Cond. 3/4" MPT		Water In/Out FPT	Q Return Width	R Return Height	S	T
						D	E	F	G	AA	BB					
006-012	in	26.1	21.2	22.0	7.1	2.1	5.5	8.1	5.5	5.1	5.5	1/2"	16.1	10.0	4.2	0.4
	cm	66.3	53.8	55.9	18.0	5.3	14.0	20.6	14.0	13.0	14.0		40.9	25.4	10.7	1.0
015-030	in	29.0	24.7	40.0	7.4	2.6	6.0	11.6	6.0	7.1	6.0	3/4"	18.1	20.0	3.8	0.3
	cm	73.7	62.7	101.6	18.8	6.6	15.2	29.5	15.2	18.0	15.2		46.0	50.8	9.7	0.8
036-042	in	29.0	28.7	45.0	7.4	2.6	6.0	12.1	6.0	7.1	6.0	3/4"	22.7	24.0	4.6	0.1
	cm	73.7	72.9	114.3	18.8	6.6	15.2	29.5	15.2	18.0	15.2		57.7	61.0	11.7	0.3
048-060	in	31.2	37.2	46.0	7.0	3.1	5.8	12.1	5.8	7.1	5.8	3/4"	29.3	24.0	5.0	0.1
	cm	79.2	94.5	116.8	17.8	7.9	14.7	30.7	14.7	18.0	14.7		74.4	61.0	12.7	0.3

Right Return with WSE

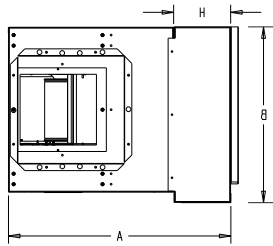

Top View

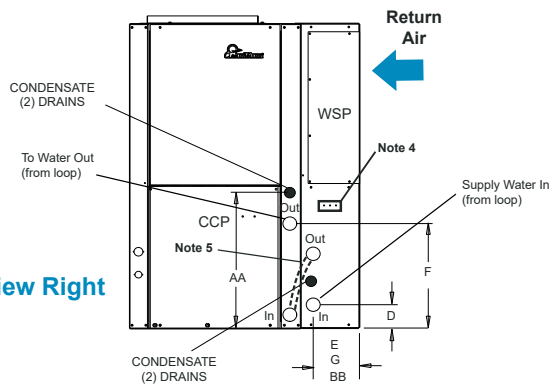
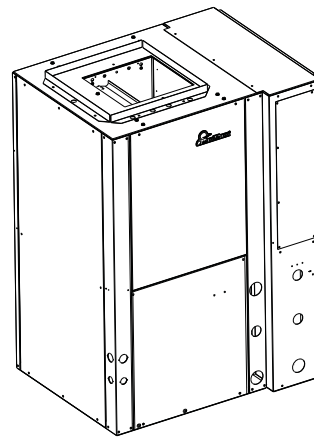

Front View Right Return

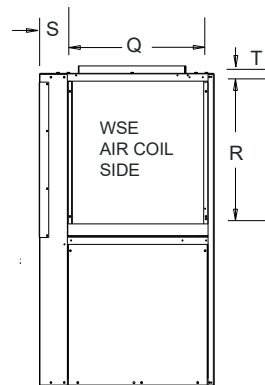

Notes:

- Units are shipped with either filter rails or filter frames depending on unit model. Air filter rails are not suitable for supporting return air duct. Air filter frames are provided with a duct mounting collar for connection to return air duct.
- WSE condensate drain is 3/4" FPT, Unit condensate drain is 3/4" MPT. Externally trap and vent both drains before joining.
- Filters same size as standard unit.
- Factory supplied controller (aquastat) is shipped inside unit. Open waterside economizer panel (WSP), remove, slide onto dinrail, and connect moxex.
- WSE to unit piping to be field fabricated below or in front. Must leave room to remove front access panel (CCP) to service unit.
- Refer to Discharge Air connection dimensions.

Vertical Units

Left Return

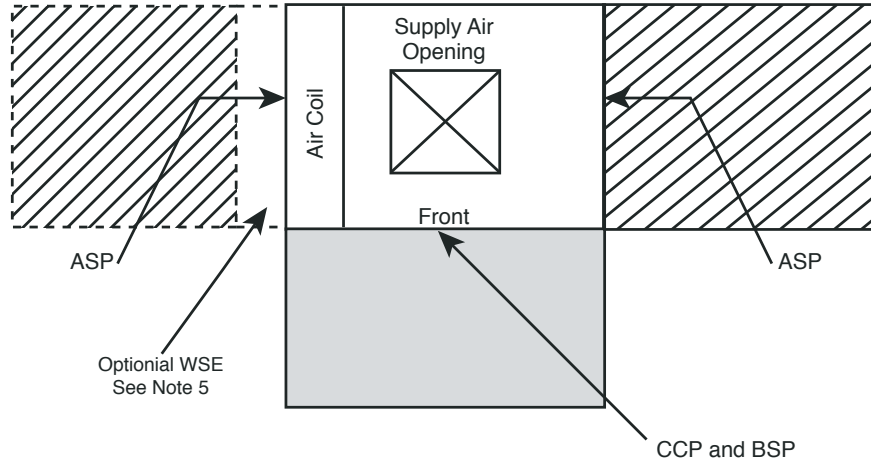

Right Return

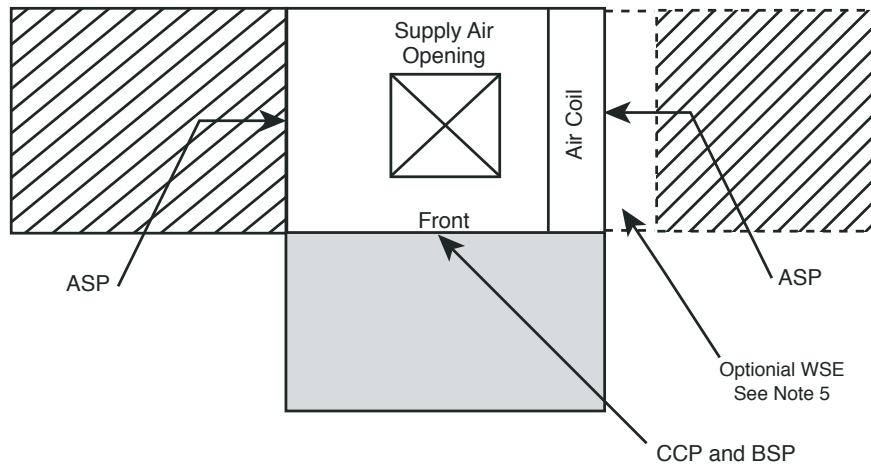

Notes:

1. While clear access to all removable panels is not required, installer should take care to comply with all building codes and allow adequate clearance for future field service.
2. Front & Side access is preferred for service access. However, units without WSE option may be serviced from the front access panel if side access is not available.
3. ASP are removable panels that provide additional access to the units interior. Clear access to ASP panels is not required and they are not to be used in place of the mandatory CCP and BSP panels.
4. Front return units (not shown) require front access for controls/compressor and left side access for blower.
5. Units with WSE Must have access to water valve through side access panel.

- = mandatory 2' service access
- = (optional) additional 2' service access

Legend:

- CCP = Control/Compressor Access Panel
- BSP = Blower Service Panel
- ASP = Additional Service Panel (not required)
- WSE = Waterside Economizer

Corner Weights for TCH Series Units

Model		Total	Left-Front*	Right-Front*	Left-Back*	Right-Back*
TCH006	Lbs	103	37	24	23	19
	kg	46.72	16.78	10.89	10.43	8.62
TCH009	Lbs	105	38	24	23	20
	kg	47.63	17.24	10.89	10.43	9.07
TCH012	Lbs	114	42	26	25	21
	kg	51.71	19.05	11.79	11.34	9.53
TCH015	Lbs	153	53	36	34	30
	kg	69	24	16	15	14
TCH018	Lbs	158	55	37	35	31
	kg	72	25	17	16	14
TCH024	Lbs	174	62	40	39	33
	kg	79	28	18	18	15
TCH030	Lbs	182	67	41	40	34
	kg	83	30	19	18	15
TCH036	Lbs	203	75	47	44	37
	kg	92	34	21	20	17
TCH042	Lbs	218	81	50	48	39
	kg	99	37	23	22	18
TCH048	Lbs.	263	98	60	58	47
	kg	119	44	27	26	21
TCH060	Lbs.	278	94	59	56	69
	kg	126	43	27	25	31

*Front is control box end.

Electrical Data: Standard Unit

MODEL	VOLTAGE CODE	RATED VOLTAGE	VOLTAGE MIN/ MAX	COMPRESSOR			FAN MOTOR FLA	TOTAL UNIT FLA	MIN CIRCUIT AMP	MAX FUSE/ HACR	SCCR kA rms symetrical	SCCR Volts Maximum
				QTY	RLA	LRA						
006	G	208-230 / 60 / 1	187.2 / 253	1	2.6	17.7	0.3	2.9	3.6	15	5	600
	E	265 / 60 / 1	238.5 / 291.5	1	2.6	13.5	0.4	3.0	3.6	15	5	600
009	G	208-230 / 60 / 1	187.2 / 253	1	3.7	22	0.8	4.5	5.5	15	5	600
	E	265 / 60 / 1	238.5 / 291.5	1	3.4	17.5	0.8	4.2	5.1	15	5	600
012	G	208-230 / 60 / 1	187.2 / 253	1	5.6	32.5	0.8	6.4	7.8	15	5	600
	E	265 / 60 / 1	238.5 / 291.5	1	4.2	31.5	0.8	5.0	6.1	15	5	600
015	G	208-230 / 60 / 1	187.2 / 253	1	5.6	29.0	0.9	6.5	7.9	15	5	600
	E	265 / 60 / 1	238.5 / 291.5	1	5.0	28.0	0.7	5.7	7.0	15	5	600
018	G	208-230 / 60 / 1	187.2 / 253	1	7.4	33.0	0.9	8.3	10.2	15	5	600
	E	265 / 60 / 1	238.5 / 291.5	1	6.0	28.0	0.7	6.7	8.2	15	5	600
024	G	208-230 / 60 / 1	187.2 / 253	1	12.8	58.3	1.5	14.3	17.5	30	5	600
	E	265 / 60 / 1	238.5 / 291.5	1	9.6	54.0	1.2	10.8	13.2	20	5	600
	F	460 / 60 / 3	414 / 506	1	3.6	28.0	1.4	5.0	5.9	15	5	600
	H	208-230 / 60 / 3	187.2 / 253	1	7.7	55.4	1.5	9.2	11.1	15	5	600
030	G	208-230 / 60 / 1	187.2 / 253	1	14.1	73.0	2.7	16.8	20.3	30	5	600
	E	265 / 60 / 1	238.5 / 291.5	1	11.2	60.0	2.9	14.1	16.9	25	5	600
	F	460 / 60 / 3	414 / 506	1	4.2	28.0	1.6	5.8	6.9	15	5	600
	H	208-230 / 60 / 3	187.2 / 253	1	8.9	58.0	2.7	11.6	13.8	20	5	600
036	G	208-230 / 60 / 1	187.2 / 253	1	16.7	79.0	2.7	19.4	23.5	40	5	600
	E	265 / 60 / 1	238.5 / 291.5	1	13.5	72.0	2.0	15.5	18.9	30	5	600
	F	460 / 60 / 3	414 / 506	1	5.8	38.0	1.2	7.0	8.5	15	5	600
	H	208-230 / 60 / 3	187.2 / 253	1	10.4	73.0	2.7	13.1	15.7	25	5	600
041*	G	208-230 / 60 / 1	187.2 / 253	1	17.9	112.0	2.7	20.6	25.1	40	5	600
	F	460 / 60 / 3	414 / 506	1	6.0	44.0	1.6	7.6	9.1	15	5	600
	H	208-230 / 60 / 3	187.2 / 253	1	13.2	88.0	2.7	15.9	19.2	30	5	600
	N	575 / 60 / 3	517.5 / 632.5	1	4.2	30.0	1.4	5.6	6.7	15	5	600
042	G	208-230 / 60 / 1	187.2 / 253	1	17.9	112.0	2.7	20.6	25.1	40	5	600
	F	460 / 60 / 3	414 / 506	1	6.0	44.0	1.6	7.6	9.1	15	5	600
	H	208-230 / 60 / 3	187.2 / 253	1	13.5	88.0	2.7	16.2	19.6	30	5	600
	N	575 / 60 / 3	517.5 / 632.5	1	4.9	34.0	1.4	6.3	7.5	15	5	600
048	G	208-230 / 60 / 1	187.2 / 253	1	21.8	117.0	3.3	25.1	30.6	50	5	600
	F	460 / 60 / 3	414 / 506	1	6.2	41.0	1.7	7.9	9.5	15	5	600
	H	208-230 / 60 / 3	187.2 / 253	1	13.7	83.1	3.3	17.0	20.4	30	5	600
	N	575 / 60 / 3	517.5 / 632.5	1	4.8	33.0	1.4	6.2	7.4	15	5	600
060	G	208-230 / 60 / 1	187.2 / 253	1	26.3	134.0	4.8	31.1	37.7	60	5	600
	F	460 / 60 / 3	414 / 506	1	7.8	52.0	2.4	10.2	12.2	15	5	600
	H	208-230 / 60 / 3	187.2 / 253	1	15.6	110.0	4.8	20.4	24.3	40	5	600
	N	575 / 60 / 3	517.5 / 632.5	1	5.8	38.9	1.8	7.6	9.1	15	5	600

* 460 volt units require a neutral connection.
 All "F" voltage units with Constant Volume (CV) ECM require a four wire power supply with neutral.
 Motors are 265 volt and are wired between one hot leg and neutral.
 All fuses Class RK-5

Electrical Data: High Static Blower

MODEL	VOLTAGE CODE	RATED VOLTAGE	VOLTAGE MIN/MAX	COMPRESSOR			FAN MOTOR FLA	TOTAL UNIT FLA	MIN CIRCUIT AMP	MAX FUSE/HACR	SCCR kA rms symmetrical	SCCR Volts Maximum
				QTY	RLA	LRA						
015	G	208-230 / 60 / 1	187.2 / 253	1	5.6	29.0	0.9	6.5	7.9	15	5	600
	E	265 / 60 / 1	238.5 / 291.5	1	5.0	28.0	0.7	5.7	7.0	15	5	600
018	G	208-230 / 60 / 1	187.2 / 253	1	7.4	33.0	0.9	8.3	10.2	15	5	600
	E	265 / 60 / 1	238.5 / 291.5	1	6.0	28.0	0.7	6.7	8.2	15	5	600
024	G	208-230 / 60 / 1	187.2 / 253	1	12.8	58.3	2.7	15.5	18.7	30	5	600
	E	265 / 60 / 1	238.5 / 291.5	1	9.6	54.0	2.9	12.5	14.9	20	5	600
	F	460 / 60 / 3	414 / 506	1	3.6	28.0	1.6	5.2	6.1	15	5	600
	H	208-230 / 60 / 3	187.2 / 253	1	7.7	55.4	2.7	10.4	12.3	20	5	600
030	G	208-230 / 60 / 1	187.2 / 253	1	14.1	73.0	2.7	16.8	20.3	30	5	600
	E	265 / 60 / 1	238.5 / 291.5	1	11.2	60.0	2.9	14.1	16.9	25	5	600
	F	460 / 60 / 3	414 / 506	1	4.2	28.0	1.6	5.8	6.9	15	5	600
	H	208-230 / 60 / 3	187.2 / 253	1	8.9	58.0	2.7	11.6	13.8	20	5	600
036	G	208-230 / 60 / 1	187.2 / 253	1	16.7	79.0	2.7	19.4	23.6	40	5	600
	E	265 / 60 / 1	238.5 / 291.5	1	13.5	72.0	2.9	16.4	19.8	30	5	600
	F	460 / 60 / 3	414 / 506	1	5.8	38.0	1.6	7.4	8.9	15	5	600
	H	208-230 / 60 / 3	187.2 / 253	1	10.4	73.0	2.7	13.1	15.7	25	5	600
042	G	208-230 / 60 / 1	187.2 / 253	1	17.9	112.0	2.7	20.6	25.1	40	5	600
	F	460 / 60 / 3	414 / 506	1	6.0	44.0	1.6	7.6	9.1	15	5	600
	H	208-230 / 60 / 3	187.2 / 253	1	13.5	88.0	2.7	16.2	19.6	30	5	600
	N	575 / 60 / 3	517.5 / 632.5	1	4.9	34.0	1.4	6.3	7.5	15	5	600
048	G	208-230 / 60 / 1	187.2 / 253	1	21.8	117.0	4.8	26.6	32.1	50	5	600
	F	460 / 60 / 3	414 / 506	1	6.2	41.0	2.4	8.6	10.2	15	5	600
	H	208-230 / 60 / 3	187.2 / 253	1	13.7	83.1	4.8	18.5	21.9	35	5	600
	N	575 / 60 / 3	517.5 / 632.5	1	4.8	33.0	1.8	6.6	7.8	15	5	600
060	G	208-230 / 60 / 1	187.2 / 253	1	26.3	134.0	5.7	32.0	38.6	60	5	600
	F	460 / 60 / 3	414 / 506	1	7.8	52.0	2.5	10.3	12.3	20	5	600
	H	208-230 / 60 / 3	187.2 / 253	1	15.6	110.0	5.7	21.3	25.2	40	5	600
	N	575 / 60 / 3	517.5 / 632.5	1	5.8	38.9	1.9	7.7	9.2	15	5	600

* 460 volt units require a neutral connection.
 All "F" voltage units with Constant Volume (CV) ECM require a four wire power supply with neutral.
 Motors are 265 volt and are wired between one hot leg and neutral.
 All fuses Class RK-5

Electrical Data: Constant Torque (CT) ECM

MODEL	VOLTAGE CODE	RATED VOLTAGE	VOLTAGE MIN/MAX	COMPRESSOR			FAN MOTOR FLA	TOTAL UNIT FLA	MIN CIRCUIT AMP	MAX FUSE/HACR	SCCR kA rms symmetrical	SCCR Volts Maximum
				QTY	RLA	LRA						
006	G	208-230 / 60 / 1	187.2 / 253	1	2.6	17.7	2.3	4.9	5.6	15	5	600
	E	265 / 60 / 1	238.5 / 291.5	1	2.6	13.5	2.3	4.9	5.6	15	5	600
009	G	208-230 / 60 / 1	187.2 / 253	1	3.7	22.2	2.3	6.0	6.9	15	5	600
	E	265 / 60 / 1	238.5 / 291.5	1	3.4	18.8	2.3	5.7	6.6	15	5	600
012	G	208-230 / 60 / 1	187.2 / 253	1	5.6	32.5	2.3	7.9	9.3	15	5	600
	E	265 / 60 / 1	238.5 / 291.5	1	4.2	31.5	2.3	6.5	7.6	15	5	600
015	G	208-230 / 60 / 1	187.2 / 253	1	5.6	29.0	2.6	8.2	9.6	15	5	600
	E	265 / 60 / 1	238.5 / 291.5	1	5.0	28.0	1.9	6.9	8.2	15	5	600
018	G	208-230 / 60 / 1	187.2 / 253	1	7.4	33.0	2.6	10.0	11.9	15	5	600
	E	265 / 60 / 1	238.5 / 291.5	1	6.0	28.0	1.9	7.9	9.4	15	5	600
024	G	208-230 / 60 / 1	187.2 / 253	1	12.8	58.3	3.9	16.7	19.9	30	5	600
	E	265 / 60 / 1	238.5 / 291.5	1	9.6	54.0	3.2	12.8	15.2	20	5	600
	F	460 / 60 / 3	414 / 506	1	3.6	28.0	1.1	4.7	5.6	15	5	600
	H	208-230 / 60 / 3	187.2 / 253	1	7.7	55.4	3.9	11.6	13.5	20	5	600
030	G	208-230 / 60 / 1	187.2 / 253	1	14.1	73.0	3.9	18.0	21.5	35	5	600
	E	265 / 60 / 1	238.5 / 291.5	1	11.2	60.0	3.2	14.4	17.2	25	5	600
	F	460 / 60 / 3	414 / 506	1	4.2	28.0	1.1	5.3	6.4	15	5	600
	H	208-230 / 60 / 3	187.2 / 253	1	8.9	58.0	3.9	12.8	15.0	20	5	600
036	G	208-230 / 60 / 1	187.2 / 253	1	16.7	79.0	6.0	22.7	26.9	40	5	600
	E	265 / 60 / 1	238.5 / 291.5	1	13.5	72.0	3.9	17.4	20.8	30	5	600
	F	460 / 60 / 3	414 / 506	1	5.8	38.0	1.5	7.3	8.8	15	5	600
	H	208-230 / 60 / 3	187.2 / 253	1	10.4	73.0	6.0	16.4	19.0	25	5	600
042	G	208-230 / 60 / 1	187.2 / 253	1	17.9	112.0	6.0	23.9	28.4	45	5	600
	F	460 / 60 / 3	414 / 506	1	6.0	44.0	1.5	7.5	9.0	15	5	600
	H	208-230 / 60 / 3	187.2 / 253	1	13.5	88.0	6.0	19.5	22.9	35	5	600
048	G	208-230 / 60 / 1	187.2 / 253	1	21.8	117.0	7.5	29.3	34.8	50	5	600
	F	460 / 60 / 3	414 / 506	1	6.2	41.0	2.1	8.3	9.9	15	5	600
	H	208-230 / 60 / 3	187.2 / 253	1	13.7	83.1	7.5	21.2	24.6	35	5	600
060	G	208-230 / 60 / 1	187.2 / 253	1	26.3	134.0	7.5	33.8	40.4	60	5	600
	F	460 / 60 / 3	414 / 506	1	7.8	52.0	2.1	9.9	11.9	15	5	600
	H	208-230 / 60 / 3	187.2 / 253	1	15.6	110.0	7.5	23.1	27.0	40	5	600

* 460 volt units require a neutral connection.
 All "F" voltage units with Constant Volume (CV) ECM require a four wire power supply with neutral.
 Motors are 265 volt and are wired between one hot leg and neutral.
 All fuses Class RK-5

Electrical Data: Constant Volume (CV) ECM

MODEL	VOLTAGE CODE	RATED VOLTAGE	VOLTAGE MIN/MAX	COMPRESSOR			FAN MOTOR FLA	TOTAL UNIT FLA	MIN CIRCUIT AMP	MAX FUSE/HACR	SCCR kA rms symmetrical	SCCR Volts Maximum
				QTY	RLA	LRA						
006	G	208-230 / 60 / 1	187.2 / 253	1	2.6	17.7	1.5	4.1	4.8	15	5	600
	E	265 / 60 / 1	238.5 / 291.5	1	2.6	13.5	1.4	4.0	4.7	15	5	600
009	G	208-230 / 60 / 1	187.2 / 253	1	3.7	22.2	1.5	5.2	6.1	15	5	600
	E	265 / 60 / 1	238.5 / 291.5	1	3.4	18.8	1.4	4.8	5.7	15	5	600
012	G	208-230 / 60 / 1	187.2 / 253	1	5.6	32.5	2.6	8.2	9.6	15	5	600
	E	265 / 60 / 1	238.5 / 291.5	1	4.2	31.5	2.5	6.7	7.8	15	5	600
015	G	208-230 / 60 / 1	187.2 / 253	1	5.6	29.0	2.6	8.2	9.6	15	5	600
	E	265 / 60 / 1	238.5 / 291.5	1	5.0	28.0	2.4	7.4	8.7	15	5	600
018	G	208-230 / 60 / 1	187.2 / 253	1	7.4	33.0	2.6	10.0	11.9	15	5	600
	E	265 / 60 / 1	238.5 / 291.5	1	6.0	28.0	2.4	8.4	9.9	15	5	600
024	G	208-230 / 60 / 1	187.2 / 253	1	12.8	58.3	3.9	16.7	19.9	30	5	600
	E	265 / 60 / 1	238.5 / 291.5	1	9.6	54.0	3.2	12.8	15.2	20	5	600
	*F	460 / 60 / 3	414 / 506	1	3.6	28.0	3.2	6.8	7.7	15	5	600
	H	208-230 / 60 / 3	187.2 / 253	1	7.7	55.4	3.9	11.6	13.5	20	5	600
030	G	208-230 / 60 / 1	187.2 / 253	1	14.1	73.0	3.9	18.0	21.5	35	5	600
	E	265 / 60 / 1	238.5 / 291.5	1	11.2	60.0	3.2	14.4	17.2	25	5	600
	*F	460 / 60 / 3	414 / 506	1	4.2	28.0	3.2	7.4	8.5	15	5	600
	H	208-230 / 60 / 3	187.2 / 253	1	8.9	58.0	3.9	12.8	15.0	20	5	600
036	G	208-230 / 60 / 1	187.2 / 253	1	16.7	79.0	6.0	22.7	26.9	40	5	600
	E	265 / 60 / 1	238.5 / 291.5	1	13.5	72.0	4.8	18.3	21.7	35	5	600
	*F	460 / 60 / 3	414 / 506	1	5.8	38.0	4.8	10.6	12.1	15	5	600
	H	208-230 / 60 / 3	187.2 / 253	1	10.4	73.0	6.0	16.4	19.0	25	5	600
042	G	208-230 / 60 / 1	187.2 / 253	1	17.9	112.0	6.0	23.9	28.4	45	5	600
	F	460 / 60 / 3	414 / 506	1	6.0	44.0	4.8	10.8	12.3	15	5	600
	H	208-230 / 60 / 3	187.2 / 253	1	13.5	88.0	6.0	19.5	22.9	35	5	600
048	G	208-230 / 60 / 1	187.2 / 253	1	21.8	117.0	7.5	29.3	34.8	50	5	600
	*F	460 / 60 / 3	414 / 506	1	6.2	41.0	6.2	12.4	14.0	15	5	600
	H	208-230 / 60 / 3	187.2 / 253	1	13.7	83.1	7.5	21.2	24.6	35	5	600
060	G	208-230 / 60 / 1	187.2 / 253	1	26.3	134.0	7.5	33.8	40.4	60	5	600
	*F	460 / 60 / 3	414 / 506	1	7.8	52.0	6.0	13.8	15.8	20	5	600
	H	208-230 / 60 / 3	187.2 / 253	1	15.6	110.0	7.5	23.1	27.0	40	5	600

* 460 volt units require a neutral connection.

All "F" voltage units with Constant Volume (CV) ECM require a four wire power supply with neutral.

Motors are 265 volt and are wired between one hot leg and neutral.

All fuses Class RK-5

TC Series Wiring Diagram Matrix

All current diagrams can be located online at climatemaster.com. Click 'Commercial Professional'.

1. Click 'Products' in the main navigation
2. Select 'Small Packaged Units'
3. Select the TC product series
4. Click the Wire Diagrams tab in the middle of the page
5. Select your voltage and controls

Unit Controller	Fan Motor	Water Side Economizer	208v/1 - 265v/1		208v/3	460v/3	575v/3	
			006-012	015-060	024-060	024-060	041-060	
CXM2	PSC	None	96B0514N11		96B0514N21	96B0514N31		
		WSE	96B0515N11		96B0515N21	96B0515N31		
	CT ECM	None	96B0514N12		96B0514N22	96B0514N32		
		WSE	96B0515N12		96B0515N22	96B0515N32		
DXM2.5	PSC	None	96B0521N11		96B0521N21	96B0521N31		
		WSE	96B0476N11		96B0476N21	96B0476N31		
	CT ECM	None	96B0527N11		96B0527N21	96B0527N31		
		WSE	96B0478N11		96B0478N21	96B0478N31		
	CV ECM	None	96B0523N01	96B0523N11	96B0523N21	96B0523N31		
		WSE	96B0477N01	96B0477N11	96B0477N21	96B0477N31		
Auxiliary WD for MPC			96B0147N14					

Tranquility® 16 (TC) Series 60 Hz Engineering Specifications – Page 1

General:

Furnish and install ClimateMaster Tranquility® “TC” Water Source Heat Pumps, as indicated on the plans. Equipment shall be completely assembled, piped and internally wired. Capacities and characteristics as listed in the schedule and the specifications that follow.

Units shall be supplied completely factory built capable of operating over an entering water temperature range from 20° to 120°F (-6.7° to 48.9°C) as standard. Equivalent units from other manufacturers may be proposed provided approval to bid is given 10 days prior to bid closing. All equipment listed in this section must be rated and certified in accordance with Air-Conditioning, Heating and Refrigeration Institute/International Standards Organization (AHRI/ISO 13256-1). All equipment must be tested, investigated, and determined to comply with the requirements of the standards for Heating and Cooling Equipment UL-1995 for the United States and CAN/CSA-C22.2 NO.236 for Canada, by Intertek Testing Laboratories (ETL). The units shall have AHRI/ISO and ETL-US-C labels.

All units shall pass a factory acceptance test. The quality control system shall automatically perform the factory acceptance test via computer. A detailed report card from the factory acceptance test shall ship with each unit. **Note: If unit fails the factory acceptance test it shall not be allowed to ship. Unit serial number will be recorded by factory acceptance test and furnished on report card for ease of unit warranty status.**

Basic Construction:

Horizontal units shall have one of the following air flow arrangements: Left Inlet/Straight (Right) Discharge; Right Inlet/Straight (Left) Discharge; Left Inlet/Back Discharge; or Right Inlet/Back Discharge as shown on the plans. Units must have the ability to be field convertible from straight to back or back to straight discharge with no additional parts or unit structure modification. Horizontal units will have factory installed hanger brackets with rubber isolation grommets packaged separately.

Vertical units shall have one of the following airflow arrangements: Left Return/Top Discharge, Right Return/Top Discharge, as shown on the plans.

If units with these arrangements are not used, the contractor is responsible for any extra costs incurred by other trades. All units (horizontal and vertical) must have a minimum of two access panels for serviceability of compressor compartment. **Units having only one access panel to compressor/heat exchangers/expansion device/refrigerant piping shall not be acceptable.**

Compressor section interior surfaces shall be lined with 1/2 inch (12.7mm) thick, 1-1/2 lb/ft³ (24 kg/m³) acoustic type glass fiber insulation. Air handling section interior surfaces shall be lined with 1/2 in (12.7mm) thick, 1-1/2 lb/ft³ (24 kg/m³) **foil-faced** fiber insulation for ease of cleaning. Insulation placement shall be designed in a manner that will eliminate any exposed edges to prevent the introduction of glass fibers into the air stream. **Units without foil-faced insulation in the air handling section will not be accepted.**

The heat pumps shall be fabricated from heavy gauge galvanized steel.

Standard insulation must meet NFPA Fire Hazard Classification requirements 25/50 per ASTM E84, UL 723, CAN/ULC S102-M88 and NFPA 90A requirements; air erosion and mold growth limits of UL-181; stringent fungal resistance test per ASTM-C1071 and ASTM G21; and shall meet zero level bacteria growth per ASTM G22. **Unit insulation must meet these stringent requirements or unit(s) will not be accepted.**

All horizontal units to have factory installed 1 inch (25.4 mm) discharge air duct collars, 1 inch (25.4 mm) filter rails with 1 inch (25.4 mm) filters factory installed, and factory installed unit-mounting brackets. Vertical units to have field installed discharge air duct collar, shipped loose and 1 inch (25.4 mm) filter rails with 1 inch (25.4 mm) filters factory installed. **If units with these factory installed provisions are not used, the contractor is responsible for any extra costs to field install these provisions, and/or the extra costs for their sub-contractor to install these provisions.**

Tranquility® 16 (TC) Series 60 Hz Engineering Specifications – Page 2

All units must have an insulated panel separating the fan compartment from the compressor compartment. **Units with the compressor in the air stream are not acceptable.** Units shall have factory installed 1 inch (25.4 mm) wide filter rails for filter removal from either side. Units shall have a 1 inch (25.4 mm) thick throwaway type glass fiber filter. The contractor shall purchase one spare set of filters and replace factory shipped filters on completion of start-up. Filters shall be standard sizes. If units utilize non-standard filter sizes then the contractor shall provide 12 spare filters for each unit.

Cabinets shall have separate holes and knockouts for entrance of line voltage and low voltage control wiring. All factory-installed wiring passing through factory knockouts and openings shall be protected from sheet metal edges at openings by plastic ferrules. Supply and return water connections shall be copper FPT fittings. All water connections and electrical knockouts must be in the compressor compartment corner post as to not interfere with the serviceability of unit. Contractor shall be responsible for any extra costs involved in the installation of units that do not have this feature. Contractor must ensure that units can be easily removed for servicing and coordinate locations of electrical conduit and lights with the electrical contractor.

Option: 2 inch (50.8 mm) filter frame with removable access door and 2 inch (50.8 mm) Glass Fiber throwaway filters on all units.

Option: UltraQuiet package shall consist of additional sound insulation applied to the base pan, removable panels and blower housing. A discharge muffler is included on sizes 015 through 060.

Option: The unit shall be supplied with extended range insulation option, which adds closed cell insulation to internal water lines, and provides insulation on suction side refrigeration tubing including refrigerant to water heat exchanger.

Option: The unit shall be supplied with Waterside Economizer (WSE). The WSE will consist of hydronic coil, 3 way valve, and aquastat. Aquastat will be adjustable type and factory set at 45° F (72° C). Units with WSE will require heat pump thermostat with 2 stages of cooling and S.S. drain pan.

Fan and Motor Assembly:

Blower shall have inlet rings to allow removal of wheel and motor from one side without removing housing. Units shall have a direct-drive centrifugal fan. The fan motor shall be 3-speed (2-speed for 575V), permanently lubricated, PSC type, with internal thermal overload protection. Units supplied without permanently lubricated motors must provide external oilers for easy service. The fan motor on small and medium size units (006-042) shall be isolated from the fan housing by a torsionally flexible motor mounting system with rubber type grommets to inhibit vibration induced high noise levels associated with “hard wire belly band” motor mounting. The fan motor on larger units (048 & 060) shall be isolated with flexible rubber type isolation grommets only. The fan and motor assembly must be capable of overcoming the external static pressures as shown on the schedule. Airflow/Static pressure rating of the unit shall be based on a wet coil and a clean filter in place. **Ratings based on a dry coil, and/or no air filter shall NOT be acceptable.**

Option: High static motors (Sizes 015-060).

Option: Constant Torque (CT) ECM motors (sizes 006 to 060 except 041): The CT ECM fan maximizes motor efficiency over its static operating range and provides airflow adjustment with 4 or 5 speed taps. The fan motor shall be isolated from the housing by rubber grommets. The motor shall be permanently lubricated and have thermal overload protection.

Option: Constant Volume (CV) ECM motors (sizes 006 to 060 except 041): CV ECM variable speed ball bearing type motor. The CV ECM fan motor shall provide a soft low noise fan start by ramping fan

Tranquility® 16 (TC) Series 60 Hz Engineering Specifications – Page 3

up to full selected speed over a 30 second period, and slowly ramp down fan at the end of each blower cycle, maintain constant CFM, maximize motor efficiency over its static operating range, and provide airflow adjustment in multiple CFM increments. The fan motor shall be isolated from the housing by rubber grommets. The motor shall be permanently lubricated and have thermal overload protection. A special dehumidification mode shall be provided to allow lower airflows in cooling for better dehumidification. The dehumidification mode may be constant or automatic (humidistat controlled). **Constant CFM ECM motors without controlled ramp up and ramp down features, with constant CFM speed taps, or with no microprocessor controller are not acceptable.**

Refrigerant Circuit:

All units shall contain an EarthPure® (HFC-410A) sealed refrigerant circuit including a high efficiency scroll or rotary compressor designed for heat pump operation, a thermostatic expansion valve for refrigerant metering, an enhanced corrugated aluminum lanced fin and rifled copper tube refrigerant to air heat exchanger, reversing valve, coaxial (tube in tube) refrigerant to water heat exchanger, and safety controls including a high pressure switch, low pressure (loss of charge) switch, water coil low temperature sensor, and air coil low temperature sensor. Access fittings shall be factory installed on high and low pressure refrigerant lines to facilitate field service. Activation of any safety device shall prevent compressor operation via a microprocessor lockout circuit. The lockout circuit shall be reset at the thermostat or at the contractor supplied disconnect switch. **Units that cannot be reset at the thermostat shall not be acceptable.**

The compressor shall have a dual level vibration isolation system. The compressor will be mounted on specially engineered sound-tested EPDM vibration isolation grommets or springs to a large heavy gauge compressor mounting plate, which is then isolated from the cabinet base with rubber grommets for maximized vibration attenuation. Compressor shall have thermal overload protection. Compressor shall be located in an insulated compartment away from air stream to minimize sound transmission.

Refrigerant to air heat exchangers shall utilize enhanced corrugated lanced aluminum fins and rifled copper tube construction rated to withstand 625 PSIG (4309 kPa) working refrigerant pressure. Refrigerant to water heat exchangers shall be of copper inner water tube and steel refrigerant outer tube design, rated to withstand 625 PSIG (4309 kPa) working refrigerant pressure and 500 PSIG (3445 kPa) working water pressure. The refrigerant to water heat exchanger shall be “electro-coated” with a low cure cathodic epoxy material a minimum of 0.4 mils thick (0.4 – 1.5 mils range) on all surfaces. The black colored coating shall provide a minimum of 1000 hours salt spray protection per ASTM B117-97 on all external steel and copper tubing. The material shall be formulated without the inclusion of any heavy metals and shall exhibit a pencil hardness of 2H (ASTM D3363-92A), crosshatch adhesion of 4B-5B (ASTM D3359-95), and impact resistance of 160 in-lbs (184 kg-cm) direct (ASTM D2794-93).

Refrigerant metering shall be accomplished by thermostatic expansion valve only. Expansion valves shall be dual port balanced type with external equalizer for optimum refrigerant metering. Units shall be designed and tested for operating ranges of entering water temperatures from 20° to 120°F (-6.7° to 48.9°C). Reversing valve shall be four-way solenoid activated refrigerant valve, which shall default to heating mode should the solenoid fail to function. If the reversing valve solenoid defaults to cooling mode, an additional low temperature thermostat must be provided to prevent over-cooling an already cold room.

Option: The unit will be supplied with cupro-nickel coaxial water to refrigerant heat exchanger.

Drain Pan:

The drain pan shall be constructed of a polymer material that inhibits corrosion. Drain outlet shall be connected from pan using provided polymer coupling and clamps that meet UL 2043 as required for discrete products by the IMC and UMC when located in a plenum. If galvanized steel drain pan is used, it shall be fully insulated on both sides and must meet the stringent 1,000 hour salt spray test per ASTM B117. Drain outlet shall be located at pan as to allow unobstructed drainage of condensate. Drain outlet shall be

Tranquility® 16 (TC) Series 60 Hz Engineering Specifications – Page 4

connected from pan directly to a rubber coupling. **No hidden internal tubing extensions from pan outlet extending to unit casing (that can create drainage problems) will be accepted.** The unit as standard will be supplied with solid-state electronic condensate overflow protection. **Mechanical float switches will NOT be accepted.**

Option: The unit shall be supplied with stainless steel drain pan with 3/4" MPT plumbing connection. The stainless steel drain pan shall be fully insulated on all sides.

Electrical:

A control box shall be located within the unit compressor compartment and shall contain a 50VA transformer, 24 volt activated, 2 or 3 pole compressor contactor, terminal block for thermostat wiring and solid-state controller for complete unit operation. The control box on sizes 015 through 060 shall have a door to protect the internal components. The entire control box shall be capable of rotating out of the unit to allow access to the components behind the control box. Low voltage wires shall enter the box through a hole in the lower left side and high voltage wires shall enter the box through a hole in the upper left side. Reversing valve and fan motor wiring shall be routed through this electronic controller. Units shall be name-plated for use with time delay fuses or HACR circuit breakers. Unit controls shall be 24 Volt and provide heating or cooling as required by the remote thermostat/sensor.

Option: Disconnect Switch, Non-Fused, classified as motor disconnect.

Enhanced Solid State Control System (CXM2):

Units shall have a solid-state control system. Units utilizing electro-mechanical control shall not be acceptable. The control system microprocessor board shall be specifically designed to protect against building electrical system noise contamination, EMI, and RFI interference. The control system shall interface with a heat pump type thermostat. The control system shall have the following features:

- a. Anti-short cycle time delay on compressor operation.
- b. Random start on power up mode.
- c. Low voltage protection.
- d. High voltage protection.
- e. Unit shutdown on high or low refrigerant pressures.
- f. Unit shutdown on low water temperature.
- g. Condensate overflow electronic protection.
- h. Option to reset unit at thermostat or disconnect.
- i. Automatic intelligent reset. Unit shall automatically reset the unit 5 minutes after trip if the fault has cleared. If a fault occurs 3 times sequentially without thermostat meeting temperature, then lockout requiring manual reset will occur.
- j. Ability to defeat time delays for servicing.
- k. The low-pressure switch shall not be monitored for the first 120 seconds after a compressor start command to prevent nuisance safety trips.
- l. 24V output to cycle a motorized water valve or other device with compressor contactor.
- m. Unit Performance Sentinel (UPS). The UPS warns when the heat pump is running inefficiently.
- n. Water coil low temperature sensing (selectable for water or anti-freeze).
- o. Air coil low temperature sensing.
- p. Minimized reversing valve operation (Unit control logic shall only switch the reversing valve when cooling is demanded for the first time. The reversing valve shall be held in this position until the first call for heating, ensuring quiet operation and increased valve life).
- q. Emergency shutdown contacts.
- r. Entering and leaving water temperature sensing.
- s. Leaving air temperature sensing.
- t. Compressor discharge temperature sensing.

Tranquility® 16 (TC) Series 60 Hz Engineering Specifications – Page 5

NOTE: Units not providing the 8 safety protections of anti-short cycle, low voltage, high voltage, high refrigerant pressure, low pressure (loss of charge), air coil low temperature cut-out, water coil low temperature cut-out, and condensate overflow protections will not be accepted.

When CXM2 is connected to AWC99U01 thermostat or handheld service tool, the installer/service technician can; check DIP switch S2 settings; run operation modes manually; check all physical inputs from thermostat and refrigerant pressure switches status, (Y1, Y2, W, O, G, H, ESD, NSB, OR, HP switch, and LOC switch); current or at time of fault the following temperatures - water coil (LT1), air coil (LT2), compressor discharge, leaving air, leaving water, entering water and control voltage; record last five faults, list possible reasons, and clear faults. When the AWC99U01 communicating thermostat is used this same functionality can be viewed and adjusted remotely in the web portal or mobile app. **Systems not providing remote access, diagnosis, and adjustment functionality will not be accepted.**

Option: Enhanced Solid State Control System (DXM2.5)

This control system is a communicating controller.

Control shall have the above-mentioned features of the CXM2 control system along with the following expanded features:

- a. Removable thermostat connector.
- b. Night setback control.
- c. Random start on return from night setback.
- d. Override temperature control with 2-hour timer for room occupant to override setback temperature at the thermostat.
- e. Dry contact night setback output for digital night setback thermostats.
- f. Ability to work with heat pump or heat/cool (Y, W) type thermostats.
- g. Ability to work with heat pump thermostats using O or B reversing valve control.
- h. Boilerless system heat control at low loop water temperature.
- i. Ability to allow up to 3 units to be controlled by one thermostat.
- j. Relay to operate an external damper.
- k. Relay to start system pump.
- l. 75 VA control transformer. Control transformer shall have load side short circuit and overload protection via a built-in circuit breaker.

NOTE: Units not providing the 8 safety protections of anti-short cycle, low voltage, high voltage, high refrigerant pressure, low pressure (loss of charge), air coil low temperature cut-out, water coil low temperature cut-out, and condensate overflow protection for both drain pans will not be accepted.

When DXM2.5 is connected to AWC99U01 communicating thermostat or handheld service tool, the installer/service technician can; check and set CFM; check DIP switch S1, S2, and S3 settings; run operation modes manually; check all physical inputs from thermostat and refrigerant pressure switches status, (Y1, Y2, W, O, G, H, ESD, NSB, OR, HP switch, and LOC switch); current or at time of fault the following temperatures - water coil (LT1), air coil (LT2), compressor discharge, leaving air, leaving water, entering water and control voltage; record last five faults, list possible reasons, and clear faults. When the AWC99U01 communicating thermostat is used this same functionality can be viewed and adjusted remotely with the only portal or mobile app. **Systems not providing remote access, diagnosis, and adjustment functionality will not be accepted.**

Digital Night Setback with Pump Restart (DXM2.5 w/ ATP32U03C/04C, AWC99U01):

The unit will be provided with a Digital Night Setback feature using an accessory relay on the DXM2.5 controller with an ATP32U03C/04C or AWC99U01 thermostat and an external, field-provided time clock. The external time clock will initiate and terminate the night setback period. The thermostat will have a night setback override feature with a programmable override time period. An additional accessory relay on the unit DXM2.5 controller will energize the building loop pump control for the duration of the override period. **(Note: This feature requires additional low voltage wiring. Consult Application Drawings for details.)**

ClimateMaster works continually to improve its products. As a result, the design and specifications of each product at the time of order may be changed without notice and may not be as described herein. Please contact ClimateMaster's Customer Service Department at 1-405-745-6000 for specific information on the current design and specifications. Statements and other information contained herein are not express warranties and do not form the basis of any bargain between the parties, but are merely ClimateMaster's opinion or commendation of its products. The latest version of this document is available at climatemaster.com. © ClimateMaster, Inc. All rights reserved 2009

Tranquility® 16 (TC) Series 60 Hz Engineering Specifications – Page 6

Remote Service Sentinel (CXM2/DXM2.5):

Solid state control system shall communicate with applicable thermostats to display (at the thermostat) the unit status, fault status, and specific fault condition, as well as retrieve previously stored fault that caused unit shutdown. The Remote Service Sentinel allows building maintenance personnel or service personnel to diagnose unit from the wall thermostat. The control board shall provide a signal to the thermostat, indicating a lockout. A detailed message shall be provided at the communicating thermostat or service tool and specific fault status such as over/under voltage fault, high pressure fault, low pressure fault, low water temperature fault, condensate overflow fault, etc. **Units that do not provide this remote service sentinel shall not be acceptable.**

Option: MPC (Multiple Protocol Control) Interface System

Units shall have all the features listed above (either CXM2 or DXM2.5) and the control board will be supplied with a Multiple Protocol interface board. Available protocols are BACnet MS/TP, Modbus, or Johnson Controls N2. The choice of protocol shall be field selectable/changeable via the use of a simple selector switch. **Protocol selection shall not require any additional programming or special external hardware or software tools.** This will permit all units to be daisy chain connected by a 2-wire twisted pair shielded cable. The following points must be available at a central or remote computer location:

- a. Space temperature.
- b. Leaving water temperature.
- c. Discharge air temperature.
- d. Command of space temperature setpoint.
- e. Cooling status.
- f. Heating status.
- g. Low temperature sensor alarm.
- h. Low pressure sensor alarm.
- i. High pressure switch alarm.
- j. Condensate overflow alarm.
- k. Hi/low voltage alarm.
- l. Fan "ON/AUTO" position of space thermostat as specified above.
- m. Unoccupied/occupied command.
- n. Cooling command.
- o. Heating command.
- p. Fan "ON/AUTO" command.
- q. Fault reset command.
- r. Itemized fault code revealing reason for specific shutdown fault (any one of 7).

This option also provides the upgraded 75VA control transformer with load side short circuit and overload protection via a built in circuit breaker.

Warranty:

ClimateMaster shall warranty equipment for a period of 12 months from start up or 18 months from shipping (which ever occurs first).

Option: Extended 4-year compressor warranty covers compressor for a total of 5 years.

Option: Extended 4-year refrigeration circuit warranty covers coils, reversing valve, expansion valve and compressor for a total of 5 years.

Option: Extended 4-year control board warranty covers the CXM2/DXM2.5 control board for a total of 5 years.

Tranquility® 16 (TC) Series 60 Hz Engineering Specifications – Page 7

FIELD INSTALLED OPTIONS

Hose Kits:

All units shall be connected with hoses. The hoses shall be braided stainless steel; fire rated hoses complete with adapters. Only fire rated hoses will be accepted.

Valves:

The following valves are available and will be shipped loose:

- a. Ball valve; bronze material, standard port full flow design, FPT connections.
- b. Ball valve with memory stop and PT port.
- c. “Y” strainer with blowdown valve; bronze material, FPT connections.
- d. Motorized water valve; slow acting, 24v, FPT connections.

Hose Kit Assemblies:

The following assemblies ship with the valves already assembled to the hose described:

- a. Supply and return hoses having ball valve with PT port.
- b. Supply hose having ball valve with PT port; return hose having automatic flow regulator valve with PT ports, and ball valve.
- c. Supply hose having “Y” strainer with blowdown valve, and ball valve with PT port; return hose having automatic flow regulator with PT ports, and ball valve.
- d. Supply hose having “Y” strainer with blowdown valve, and ball valve with PT port; return hose having ball valve with PT port.

Thermostats:

The thermostat shall be a ClimateMaster mechanical or electronic type thermostat as selected below with the described features:

a. Thermostat (Communicating) (AWC99U01)

An electronic communicating web-enabled touchscreen thermostat shall be provided. The thermostat shall offer three stages of heating and two stages of cooling with precise temperature control and have a four-wire connection to the unit. The thermostat shall be capable of manual or automatic change-over operation and shall operate in standard or programmable mode. An integrated humidity control feature shall be included to control a humidifier and/or a dehumidifier. The thermostat shall include a utility demand reduction feature to be initiated by an independent time program or an external input.

The thermostat shall provide access to via the web portal or mobile application to include temperature adjustment, schedule adjustment including occupied/unoccupied, entering water temperature, leaving water temperature, water coil temperature, air coil temperature, leaving air temperature, and compressor discharge temperature. A graphical system layout to be provided with real-time operating mode information of the temperature sensors for easy diagnostics.

The thermostat shall display system faults with probable cause and troubleshooting guidance. The system shall provide in clear language last five faults, time of faults, operating temps at time of fault, and possible reasons for the fault. The thermostat shall provide access for immediate manual control of all outputs via the web portal/mobile application for rapid troubleshooting.

Tranquility® 16 (TC) Series 60 Hz Engineering Specifications – Page 8

b. Single-Stage Digital Auto or Manual Changeover (ATA11U01)

Thermostat shall be a single-stage, digital, auto or manual changeover with HEAT-OFF-COOL-AUTO system switch and fan ON-AUTO switch. Thermostat shall have an LCD display with temperature and setpoint(s) in °F or °C. The Thermostat shall provide permanent memory of setpoint(s) without batteries. A fault LED shall be provided to display specific fault condition. Thermostat shall provide temperature display offset for custom applications.

c. Multi-stage Manual Changeover Programmable 5/2 Day (ATP21W02)

Thermostat shall be 5 day/2 day programmable (with up to 4 setpoints per day), multi-stage (2H/1C), manual changeover with HEAT-OFF-COOL-EM HEAT system settings and fan ON-AUTO settings. Thermostat shall have an LCD display with temperature, setpoint(s), mode, and status indication. The temperature indication shall be selectable for °F or °C. The thermostat shall provide permanent memory of setpoint(s) without batteries. Thermostat shall provide convenient override feature to temporarily change setpoint.

d. Multi-stage Automatic or Manual Changeover Programmable 7 Day (ATP32U03C)

Thermostat shall be 7 day programmable (with up to 4 setpoints per day), multi-stage (3H/2C), automatic or manual changeover with HEAT-OFF-COOL-AUTO-EM HEAT system settings and fan ON-AUTO settings. Thermostat shall have a blue backlit dot matrix LCD display with temperature, setpoints, mode, and status indication. The temperature indication shall be selectable for °F or °C. Time display shall be selectable for 12 or 24 hour clock. Fault identification shall be provided (when used with ClimateMaster CXM2 or DXM2.5 controls) to simplify troubleshooting by providing specific unit fault at the thermostat with red backlit LCD during unit lockout. The thermostat shall provide permanent memory of setpoints without batteries. Thermostat shall provide heating setpoint range limit, cooling setpoint range limit, temperature display offset, keypad lockout, dead-band range setting, and inter-stage differential settings. Thermostat shall provide progressive recovery to anticipate time required to bring space temperature to the next programmed event. Thermostat shall provide an installer setup for configuring options and for setup of servicing contractor name and contact information. Thermostat shall allow the use of an accessory remote and/or outdoor temperature sensor (AST008). Thermostat navigation shall be accomplished via five buttons (up/down/right/left/select) with menu-driven selections for ease of use and programming.

e. Multistage Automatic or Manual Changeover Programmable 7 Day with Humidity Control (ATP32U04C)

Thermostat shall be 7 day programmable (with up to 4 setpoints per day), multi-stage (3H/2C), automatic or manual changeover with HEAT-OFF-COOL-AUTO-EM HEAT system settings and fan ON-AUTO settings. Separate dehumidification and humidification setpoints shall be configurable for discreet outputs to a dehumidification option and/or an external humidifier. Installer configuration mode shall allow thermostat dehumidification mode to operate with ClimaDry® II reheat or with ECM fan dehumidification mode via settings changes. Thermostat shall have a blue backlit dot matrix LCD display with temperature, relative humidity, setpoints, mode, and status indication. The temperature indication shall be selectable for °F or °C. Time display shall be selectable for 12 or 24 hour clock. Fault identification shall be provided (when used with ClimateMaster CXM2 or DXM2.5 controls) to simplify troubleshooting by providing specific unit fault at the thermostat with red backlit LCD during unit lockout. The thermostat shall provide permanent memory of setpoints without batteries. Thermostat shall provide heating setpoint range limit, cooling setpoint range limit, temperature display offset, keypad lockout, dead-band range setting, and inter-stage differential settings. Thermostat shall provide progressive recovery to anticipate time required to bring space temperature to the next programmed event. Thermostat shall provide an installer setup for configuring options and for setup of servicing contractor name and contact information. Thermostat shall allow the use of an accessory remote and/or outdoor temperature sensor (AST008). Thermostat navigation shall be accomplished via five buttons (up/down/right/left/select) with menu-driven selections for ease of use and programming.

Tranquility® 16 (TC) Series 60 Hz Engineering Specifications – Page 9

f. CM100 - Multi-stage Automatic or Manual Changeover digital thermostat (ATA32V01)

Multi-stage (3H/2C), automatic or manual changeover with HEAT-OFF-COOL-AUTO-EM HEAT system settings and fan ON-AUTO settings. Thermostat shall have a green backlit LED display with temperature, setpoints, mode, and status indication via a green (cooling) or red(heating) LED. The temperature indication shall be selectable for °F or °C. Time display shall be selectable for 12 or 24 hour clock. The thermostat shall provide permanent memory of setpoints without batteries. Thermostat shall provide heating setpoint range limit, cooling setpoint range limit, temperature display offset, keypad lockout, dead-band range setting, and inter-stage differential settings. Thermostat shall provide progressive recovery to anticipate time required to bring space temperature to the next programmed event. Thermostat shall provide an installer setup for configuring. Thermostat navigation shall be accomplished via four buttons (Mode/fan/down/up) with menu-driven selections for ease of use and programming.

g. CM300 – Multi-stage, Automatic or Manual Changeover, 7-day Programmable with Wi-Fi and Humidity Control (AVB32V02C)

Residential version shall be 7 day programmable with up to 4 setpoints per day. Commercial version shall be 7 day programmable with 4 occupied/unoccupied periods per day with up to 4-hour override. Multi-stage (3H/2C), automatic or manual changeover with HEAT-OFF-COOL-AUTO-EM HEAT system settings and fan ON-AUTO settings, Wi-Fi, pre-occupancy purge fan option, night time control of display backlight, bi-color LED indicates a heating or cooling demand, keypad lock, title 24 compliant, openADR2.0b certified with Skyport web portal. Compatible with condensate overflow warning systems – lockout compressor with message on.

h. CM500 – Color Touchscreen Display, Multi-stage, Automatic or Manual Changeover, 7-day Programmable with Wi-Fi and Humidity Control (AVB32V03C)

Thermostat shall have color resistive touchscreen display with space temperature, relative humidity, setpoints, mode, status indication and local weather (if connected to Wi-Fi). Residential version shall be 7 day programmable with up to 4 setpoints per day. Commercial version shall be 7 day programmable with 4 occupied/unoccupied periods per day with up to 4-hour override. Multi-stage (3H/2C), automatic or manual changeover with HEAT-OFF-COOL-AUTO-EM HEAT system settings and fan ON-AUTO settings, Wi-Fi, pre-occupancy purge fan option, customizable screen saver and background displays, indicator on display indicates a heating or cooling demand, set-point lock, title 24 compliant, openADR2.0b certified with Skyport web portal. Compatible with condensate overflow warning systems – lockout compressor with message on the display. Capable of being monitored by 3rd party software. Compatible with AST014 Wi-Fi remote sensor. Configurator mobile app or web portal for easy setup. Separate dehumidification and humidification setpoints shall be configurable for discreet outputs to a dehumidification option and/or an external humidifier. The temperature indication shall be selectable for °F or °C. Time display shall be selectable for 12- or 24-hour clock. The thermostat shall provide permanent memory of setpoints without batteries. Thermostat shall provide heating setpoint range limit, cooling setpoint range limit, temperature display offset, dead-band range setting, and inter-stage differential settings. Thermostat shall provide progressive recovery to anticipate time required to bring space temperature to the next programmed event. Thermostat shall provide access to a web portal and mobile app for installer setup for configuring options. Thermostat shall have menu-driven selections for ease of use and programming.

DDC Sensors:

ClimateMaster wall mounted DDC sensor to monitor room temperature and interfaces with optional interface system described above. Several types as described below:

- a. Sensor only with no display (MPC).
- b. Sensor with setpoint adjustment and override (MPC only).
- c. Sensor with setpoint adjustment and override, LCD display, status/fault indication (MPC).

Tranquility® 16 (TC) Series 60 Hz Engineering Specifications – Page 10

NOTICE! This product specification document is furnished as a means to copy and paste ClimateMaster product information into project specification. It is not intended to be a complete list of product requirements. This document is an excerpt from the product submittal and must not be used without consulting the complete product submittal. For complete product installation and application requirements, please consult the complete product submittal. ClimateMaster is not responsible for misuse of this document or a failure to adequately review specific requirements in the product submittal.

Performance Sheet

SUBMITTAL DATA - I-P UNITS

Unit Designation: _____

Job Name: _____

Architect: _____

Engineer: _____

Contractor: _____

PERFORMANCE DATA

Cooling Capacity: _____ Btuh

EER: _____

Heating Capacity: _____ Btuh

COP: _____

Ambient Air Temp: _____ °F

Entering Water Temp (Clg): _____ °F

Entering Air Temp (Clg): _____ °F

Entering Water Temp (Htg): _____ °F

Entering Air Temp (Htg): _____ °F

Airflow: _____ CFM

Fan Speed or Motor/RPM/Turns: _____

Operating Weight: _____ (lb)

ELECTRICAL DATA

Power Supply: _____ Volts

_____ Phase _____ Hz

Minimum Circuit Ampacity: _____

Maximum Overcurrent Protection: _____

SUBMITTAL DATA - S-I UNITS

Unit Designation: _____

Job Name: _____

Architect: _____

Engineer: _____

Contractor: _____

PERFORMANCE DATA

Cooling Capacity: _____ kW

EER: _____

Heating Capacity: _____ kW

COP: _____

Ambient Air Temp: _____ °C

Entering Water Temp (Clg): _____ °C

Entering Air Temp (Clg): _____ °C

Entering Water Temp (Htg): _____ °C

Entering Air Temp (Htg): _____ °C

Airflow: _____ l/s

Fan Speed or Motor/RPM/Turns: _____

Operating Weight: _____ (kg)

ELECTRICAL DATA

Power Supply: _____ Volts

_____ Phase _____ Hz

Minimum Circuit Ampacity: _____

Maximum Overcurrent Protection: _____

Revision History

Date:	Item:	Action:
8/25/23	Pages 17-21	Updated catalog data performance for sizes 06-09
1/24/23	All	Transitioned CXM to CXM2 and DXM2 to DXM2.5 unit controls. Introduced AWC Wi-Fi communicating color touchscreen thermostat
8/12/22	Pages 5 and 73	Updated communicating controls description page. Updated wire diagram part # matrix.
7/20/22	Pages 8 and 62	Added page to describe the CT ECM blower motor functionality. Added dimensional drawings for front return units
09/27/21	All	Removed LON Controls
08/25/21	Engineering Specifications	Added drain pan insulation text
07/08/21	Introduced Polymer Drain Pans. Discontinued Painted Galvanized Pans. Increased the height of vertical sizes 015 and 018.	Updated
01/22/21	Page 5, 66-69	Updated Legend/Glossary of Abbreviations and Electrical Data with SCCR columns
11/18/20	Page 8	Updated ASHRAE performance data
11/6/20	Page 72-81	Updated Engineering Specs
7/8/20	Page 73	Updated Engineering Spec
7/7/20	Pages 18-19, 57-58, 62-63, 70	Updated Performance Tables for size 018, Added note to WSE Dimensional Data, Updated Wiring Diagram Matrix
5/13/20	ALL	Converted from DXM to DXM2, Updated all data tables
4/17/20	Pages 36-47	Updated Blower Performance Tables
4/14/20	Pages 10-32	Updated Performance Tables
3/25/20	Page 4	Added two ECM bullet Points to "Available Options"
	Page 50	New Section Added
	Page 83	Updated Engineering Specs Under "Fan & Motor Assembly" with two ECM Options
3/9/20	Page 8	Updated ASHRAE Tables
2/14/20	Page 65-68	Updated Electrical Data Tables
2/10/20	ALL	Updated fonts
09/19/19	Page 8	Text updates
7/25/19	Page 8	Updated Performance Data Tables
6/11/19	All	Updated with ECM constant torque
11/27/18	Electrical service disconnect	Added
	Page 8	Updated TC006
4/2/18	Unit photos	Changed unit photos from black to steel color
03/8/18	Page 71	Update Text
11/14/17	Page 43	Updated dimensions D, F, O
11/2/17	Page 58	Added WSE DIP setting table
10/6/17	Page 54	Edit size 015 'E' FLA, MCA
06/14/17	Page 41	Update drawing
1/30/17	Page 48,49,52	Update WSE Notes
11/4/16	Page 7	Updated 018 awhp rating
11/1/16	Update Document Design	Updated
07/1/16	Page 20,22,25,27,29	Updated Nominal Airflow
06/23/16	All	Updated cabinet photo and description
05/16/16	Table Updates	Updated
10/6/16	Pages 14,18,22,25,27,69	Update Airflow, Heat of rejection, ECM option text
9/27/16	Pages 44,45,48	Corrected TCH Left Hand WSE 048-060 Dim Q
9/7/16	Page 53, cover	updated size 041 voltage codes and cabinet photo
4/20/16	All	Msc. text and wiring diagram updates
4/8/16	Page 8	Update performance data tc009 COP

Revision History

Date:	Item:	Action:
02/25/16	Page 65 and 66	Updated run test and ECM blower description
02/18/16	Pages 39 and 40	Update Text
11/30/15	Various	Adding WSE to TCH and TCV
10/22/15	Page 25	Updated heating data
08/31/15	Page 7	Revision Level Corrected
07/31/15	Engineering Specifications and Unit Features	Updated, ECM Options Text, Edited Compressors Mount Text
04/29/15	Page 41	Updated Notes
03/03/15	Page 16	Updated 018 ECM Performance Data
02/06/15	Page 7	Changed E-Coated to Tin-Plated
02/03/15	All	Updated Rated Airflows ECM
01/21/15	Engineering Specifications	Added ECM Option Text
01/15/15	Pages 39 and 43	Updated Diagram; Added Text
01/05/15	ECM Blower Option	Added
09/30/14	Page 47	Updated
07/15/14	Page 18	Added WPD
06/16/14	Pages 4, 8 & 46	Updated Text & Table
05/29/14	Physical Data Table	Removed Fan Motor (hp)
05/12/14	Physical Data Table	Updated Ref. Charge 024 and Unit Maximum Working Water Pressure
02/11/13	Unit Features	Updated
02/06/13	TCV041 M, N, Q Dimensions page 30	Updated
02/04/13	TCV Right Return Electrical Tables	Updated Blower Orientation Miscellaneous Edits
09/27/12	TCH060 Corner Weights Recommended Minimum Installation Clearances for Vertical Units *	Corrected Added
05/02/12	Size 041	ISO Table Updated
04/30/12	Horizontal Dimensional Data Table	Updated
02/20/12	Engineering Specifications	Updated
01/23/12	Size 041	Added
09/19/11	Size 024	Added "H" and "F" Voltage
08/09/11	Unit Maximum Working Water Pressure	Updated to Reflect New Safeties
08/03/11	Engineering Specifications	Added Digital Night Setback with Pump Restart (DXM w/ ATP32U03/04)
06/17/11	Coated Air Coil Option	Changed Description
04/07/11	Engineering Specification NOTICE	Updated
02/11/11	Performance Data Selection Notes	Updated
01/03/11	Format - All Pages	Updated
09/28/10	Engineering Specifications	Updated
09/28/10	Physical Data Table	Updated-Added Coax Volume Data
09/01/10	012 'E' Airflow Correction Table	Added/Corrected
07/26/10	Wiring Diagrams	Updated
07/26/10	Compressor Mounting Information and Graphics Engineering Specifications	Updated to Reflect Spring/Grommet Change
06/11/10	Format - All Pages	Updated
06/11/10	Engineering Specifications	Updated
04/23/10	Updated (Page 1) of Engineering Specifications	Paragraph edit to update ARI to AHRI
04/22/10	LEED®, Tranquility® 16, EarthPure®	Updated format (®™ etc)
09/25/09	Performance Data Selection Notes	Example Updated
09/09/09	Engineering Specification - Fan 2 Motor Assembly	Changed 'dry' to 'wet'
09/09/09	Engineering Specification - Thermostat	Changed ATP32U01, 02 to 03, 04
09/03/09	Fan and Motor Assembly Engineering Spec.	Changed 'dry' to 'wet'

Revision History

Date:	Item:	Action:
09/03/09	Thermostat Engineering Spec.	Removed ATP11N01, Changed ATP32U01, 02 to 03, 04
05/27/09	Stand-Alone and Big Book Submittals	Consolidated
05/06/09	Dimensional Data Tables	Condensate Column Added to Water Connections Table, Rows Consolidated in Cabinet, Knockout and Discharge Tables
04/14/09	006-012 unit data added	
02/25/09	First Published	



A **NIBE** GROUP MEMBER

7300 S.W. 44th Street
 Oklahoma City, OK 73179
 Phone: 405-745-6000
 climatemaster.com

ClimateMaster works continually to improve its products. As a result, the design and specifications of each product at the time of order may be changed without notice and may not be as described herein. Please contact ClimateMaster's Customer Service Department at 1-405-745-6000 for specific information on the current design and specifications. Statements and other information contained herein are not express warranties and do not form the basis of any bargain between the parties, but are merely ClimateMaster's opinion or commendation of its products. The latest version of this document is available at climatemaster.com. © ClimateMaster, Inc. All rights reserved 2009