

# Tranquility® Ducted Vertical Stack (TSL) Series

## Submittal Data

Models TSL09-36, 60Hz - HFC-410A



LC1007

Rev.: March 8, 2023



A NIBE GROUP MEMBER

ClimateMaster works continually to improve its products. As a result, the design and specifications of each product at the time of order may be changed without notice and may not be as described herein. Please contact ClimateMaster's Customer Service Department at 1-405-745-6000 for specific information on the current design and specifications. Statements and other information contained herein are not express warranties and do not form the basis of any bargain between the parties, but are merely ClimateMaster's opinion or commendation of its products. The latest version of this document is available at [climatemaster.com](http://climatemaster.com). © ClimateMaster, Inc. All rights reserved 2014



# TSL Vertical Stack Series

	Introduction	5
	Features, Options and Accessories	6
	iGate® 2 Communicating Controls Powered by CXM2	8
	iGate® 2 Communicating Controls Powered by DXM2.5	9
	iGate® 2 Communicating (AWC) Thermostat	10
	myUplink – Web and Mobile Interface	11
	Constant Volume (CV) – ECM	12
	Constant Torque (CT) – ECM	13
	vFlow® Modulating Water Valve	14
	Selection Procedure	15
	TSL Series Nomenclature – D Cabinet	17
	TSL Hybrid Series Nomenclature – E Cabinet	19
	TSL Series Nomenclature – Chassis	22
	TSL Series Accessory Nomenclature	24
	Performance Data – AHRI/ASHRAE/ISO 13256-1. English (I-P) Units	27
	Performance Data – AHRI/ASHRAE/ISO 13256-1. Metric (S-I) Units	28
	Performance Data – Selection Notes	29
	Performance Data – TSL09 with PSC Motor	30
	Performance Data – TSL12 with PSC Motor	31
	Performance Data – TSL15 with PSC Motor	32
	Performance Data – TSL18 with PSC Motor	33
	Performance Data – TSL24 with PSC Motor	34
	Performance Data – TSL30 with PSC Motor	35
	Performance Data – TSL36 with PSC Motor	36
	Performance Data – TSL09 with ECM Motor	37
	Performance Data – TSL12 with ECM Motor	38
	Performance Data – TSL15 with ECM Motor	39
	Performance Data – TSL18 with ECM Motor	40
	Performance Data – TSL24 with ECM Motor	41
	Performance Data – TSL30 with ECM Motor	42
	Performance Data – TSL36 with ECM Motor	43
	Performance Data – TSL09 Hybrid	44
	Performance Data – TSL12 Hybrid	45
	Performance Data – TSL15 Hybrid	46
	Performance Data – TSL18 Hybrid	47



# TSL Vertical Stack Series



Performance Data – TSL24 Hybrid	48
Performance Data – TSL30 Hybrid	49
Performance Data – TSL36 Hybrid	50
Performance Data – Correction Tables	51
Antifreeze Correction Table	52
Hybrid Performance Data – Correction Tables	54
Blower Performance Data – TSL09 (PSC/ CT ECM/CV ECM)	55
Blower Performance Data – TSL12 (PSC/ CT ECM/CV ECM)	56
Blower Performance Data – TSL15 (PSC/ CT ECM/CV ECM)	57
Blower Performance Data – TSL18 (PSC/ CT ECM/CV ECM)	58
Blower Performance Data – TSL24 (PSC/ CT ECM/CV ECM)	59
Blower Performance Data – TSL30 (PSC/ CT ECM/CV ECM)	60
Blower Performance Data – TSL36 (PSC/ CT ECM/CV ECM)	61
Performance Data – Ducted CV ECM	62
Physical Data	63
Hybrid Physical Data	64
Electrical Data – PSC Motor (208/230V) and (265V)	65
Electrical Data – CV ECM Motor (208/230V) and (265V)	66
Electrical Data – CT ECM Motor (208/230V) and (265V)	67
TSL Series Wiring Diagram Matrix	68
Standard Unit - Exploded View	69
Hybrid Unit - Exploded View	70
D Cabinet	71
Leader/Follower Cabinet	72
D Cabinet Dimensions	73
D Cabinet Slot Dimensions and Riser Arrangements	74
E Cabinet Dimensions	75
E Cabinet Slot Dimensions and Riser Arrangements	76
Typical Cabinet with "G" Panel Installation	77
Typical Recessed Cabinet w/"G" Panel and Frame Installation	78
Hinged "G" Style Return Air Panel – AVHSG Series	79
"L" Style (Flush Mounting) Return Air Panel – AVHRL Series	80
Hose Kits and Stands	81
Supply Air Openings and Grilles	82
Thermostats	84
TSL Cabinet Options	86
Riser Definitions	87

# TSL Vertical Stack Series

Riser GPM Definitions and Sizing	88
Riser Diameter Sizing	89
Swage Riser Length Definitions and Sizing	90
Swage Riser Extension Definitions and Calculations	91
Slab Hole Chart - 3 Pipe	92
Shipping	93
Engineering Specifications	96
Pre-Engineered Factory Design Specials	108
Performance Sheet	109
Revision History	110





## TRANQUILITY® VERTICAL STACK (TSL) SERIES WITH EARTHPURE® REFRIGERANT

---

The Tranquility® Vertical Stack (TSL) Series offers an innovative, labor-saving solution for spaces where individual, quiet control of the heating and cooling systems is important. Vertical stack products are designed for multi-story buildings where floor to floor footprints are similar. They utilize vertically mounted water lines known as risers installed in a wall or mechanical shaft to minimize space, material, and connections. The TSL Series system consists of two major components – a cabinet located behind a finished wall and a slide in and out refrigeration chassis. This allows for the riser and cabinet pieces of the system to be installed early in the construction phase so they can be framed around without exposing the refrigeration chassis to the harsh construction environment. At the finishing stages of construction when the system is ready to be commissioned, the slide in chassis is quickly and easily installed. The TSL Series system offers a proven solution that is designed and manufactured in America, exceeds ASHRAE 90.1 efficiencies, contractor/technician friendly, has a compact foot print minimizing its impact on salable space, maximizes comfort levels of occupants, and has been proven as a preferred system in thousands of multi-story building applications across North America.

The TSL series is available in seven sizes ranging from 3/4 ton (2.6 kW) through 3 tons (10.6 kW). The cabinet has been designed with flexibility offering five different supply air locations and four different riser connection locations that can be factory or field configured. The chassis is designed for quick installation with two water hose connections and three or four electrical quick connectors. Both pieces of the system offer options to increase a buildings energy efficiency. Integrated water control options save system watts by preventing over pumping both when the unit is in operation and when its not. ECM fan motors maximize the systems airflow movement efficiency. Industry exclusive advanced communicating controls offer reduced start-up and commissioning time by providing an easy to read gateway into the systems operating conditions.

High-end condos/apartments/hotels demand the highest level of occupant comfort. Not only is it important for the system to provide heating, cooling, and dehumidification it must do so at quiet operating levels. ClimateMaster's double isolation compressor mounting system makes the TSL Series the quietest vertical stack unit on the market. Compressors are mounted on specially engineered sound-tested isolation grommets to a heavy gauge base pan, which is then isolated

from the cabinet base with a second layer of grommets under the condensate pan to provide superior sound attenuation by design. ClimateMaster offers an UltraQuiet sound attenuation package and cabinet isolation pad to meet the demand of the most sound sensitive applications.

iGate® 2 technology provides technicians an interface into the operation of the system in real time without the need for hard tooling. On board advanced controls communicate the key operating system temperatures allowing technicians to start-up, commission, and service the equipment remotely by smart phone or website via the cloud. Communication can also be done at the unit via a communicating thermostat or handheld service tool. Not only does iGate 2 monitor current performance, it also allows the functionality to make system adjustments and captures operating conditions at time of fault. All this information is displayed in an easy to read format maximizing the usability of the experience.

vFlow® variable water flow technology takes water flow control and system operating range to the next level. The functionality of an on/off water valve and water flow regulator are combined into one modulating water valve component. With a modulating valve water flow is controlled to maintain a set temperature difference between entering and leaving water while in normal operation. When in extreme entering water conditions the vFlow system switches its operation to maintain a leaving water temperature. With the functionality to control water flow to a leaving water temperature, the TSL's operational range is expanded beyond other water source heat pumps with an ability to function in heating or cooling modes across the entire entering water range of 30–120°F. While not in operation the valve remains closed preventing excessive water flow. vFlow increases system water flow efficiency by only allowing the right amount of water flow needed when it needs. Advanced iGate controls paired with the vFlow system provide functionality and efficiency unmatched in the marketplace.

Hybrid hydronic heating combines the benefits of water source heat pumps and hydronic fan coils into one system. In cooling mode the system performs as normal using a compressor and refrigerant coil. In the heating mode the system uses a second hydronic coil for heating. By design, the system reduces compressor cycling, consumes less power at the unit in heating mode, and does not require a reversing valve to be used. Hybrid systems are an ideal fit for applications where hot water is provided as a domestic utility or can be generated high efficiently.

The TSL Vertical Stack Water-Source Heat Pump Series provides energy efficiency with superior sound attenuation by design while offering options flexibility, field convertibility, and unmatched industry leading technology.

# Features, Options and Accessories

## FEATURES

- Sizes 09 (3/4 ton, 2.6 kW) through 36 (3 ton, 10.6 kW)
- Environmentally-friendly EarthPure® (HFC-410A) zero ozone depletion refrigerant
- High efficiency rotary and scroll compressors
- Exceeds ASHRAE 90.1 efficiencies
- Removable chassis allows staged installation and ease of maintenance
- Coaxial heat exchanger
- Galvanized steel cabinet
- Chassis rests on rubber grommets isolated condensate pan for vibration reduction
- Double isolation of compressor for quiet operation
- TXV metering device
- Cabinet construction for unit or remote-mounted controls
- PSC fans capable of two speeds
- Microprocessor controls with 8 standard safeties
- Unit Performance Sentinel performance monitoring system
- Integrated drain pan with condensate overflow sensor
- Field convertible supply air on all sides and the top
- Field convertible riser supply, return, and condensate locations on the left, right, or back sides
- iGate® 2 Communicating Controls Powered by CXM2
  - Multiple communication pathways,
    - o Cloud-based connectivity via iGate 2 Wi-Fi communicating color touch screen thermostat for remote monitoring, access, and diagnosis. Including the new functionality for contractors/building engineers to monitor and make mass changes on multi-unit systems
    - o Connect directly to the system with use of a handheld service tool
  - Provides real-time unit operating conditions
  - Reduces start-up, commissioning, and service time by removing the need for hard tooling to take temperature measurements
  - Captures operating conditions in the event of a safety shutdown

## OPTIONS

- iGate® 2 Communicating Controls Powered by DXM2.5
  - Includes all of the features listed above for CXM2 controls including cloud-based connectivity via iGate 2 Wi-Fi communicating color touch screen thermostat for remote monitoring, access, and diagnosis
  - Provides direct control over intelligent Constant Volume (CV) ECM fan motor
- vFlow® modulating water flow
  - Modulates water flow to maintain a water temperature differential
  - Changes operation to modulate to a leaving water temperature during extreme entering water temperatures
  - Provides ultimate variable water flow control
  - Functionally operates as both a water flow regulator and water close off valve
- 2" Filter Rail to support higher indoor air quality filters
- BACnet (MSTP), Modbus and Johnson N2 compatibility options for DDC controls
- Factory configured supply air openings with or without dust protection
- Full port shut-off valves with memory stop, for supply and return risers.
- Unit integrated power disconnect
- Field quick connect thermostat whips in 15', 25', and 35' lengths
- Factory mounted high density rubber isolation pad
- Easy to clean rust prohibitive stainless steel drain pans
- High efficient ECM fan motors
  - Intelligent Constant Volume (CV) ECM motors for ultimate airflow control
  - Entry level Constant Torque (CT) ECM motors that provide efficiency at a value
- Extended range insulation for geothermal applications
- Auto flow regulators that limit water flow to the unit preventing system over pumping
- Two-way motorized water valves that prevent water flow through the unit when it is not in operation increasing system pumping efficiency (fail opened or fail closed options)
- Three-way motorized water valves that allow continuous water flow through the water loop, reducing pressure drop when the unit is not in operation (usually applied on the top floor of a system)
- Internally mounted water pump for single pipe systems
- Corrosive resistant cupro-nickel water heat exchanger
- RIB relay (sizes 09-18) box for quiet contactor closer
- UltraQuiet sound attenuation package
- Tin-lated air coils for added protection from formicary corrosion

## Features, Options and Accessories, Cont'd.

### ACCESSORIES

- Copper risers
  - Swaged ends ready for quick drop in connection when brazing is used
  - End treatment ready for crimped (torch-less) style connections
- Unit stands that prevent clearance issues with tall baseboards
- Single, Double, and Double deflection with opposed dampers supply air grilles
- Fresh air frame kit for connection to outdoor air ducting
- Flush Mounted Return Air Panel (L Style) with fixed frame and removable panel for easy chassis access/removal
  - Available in Bright White or Polar Ice paint colors
- Attractive return air panel with hinged access door (G style)
  - Key Lock Option
  - Available in Bright White or Polar Ice paint colors
- Stainless steel braided hose kits for connection from piping risers to the chassis
- Selection of thermostats including programmable, Wi-Fi, and color touch screen
- Filters - 1" (Merv 8 or 11) or 2" (Merv 8 or 13)





# iGate<sup>®</sup> 2 Communicating Controls Powered by CXM2

## iGate<sup>®</sup> 2 Communication – Cloud connected, web-enabled information gateway to monitor, control, and diagnose your system

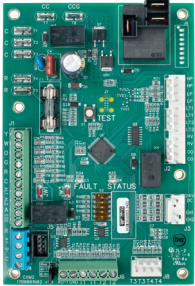

Tranquility<sup>®</sup> Vertical Stack (TSL) Series is equipped with industry-first, iGate<sup>®</sup> 2 communication information gateway that allows users to interact with their water-source system in easy to read clear language.

**Monitor/Configure** – Installers can configure from the myUplink PRO website, mobile app, iGate 2

Communicating (AWC) Thermostat, or diagnostic tool, including: Unit family, size, accessory configuration, and demand reduction (optional, to limit unit operation during peak times). Users can look up the current system status: temperature sensor readings and operational status of the blower.

**Precise Control** – The new CXM2 board enables intelligent, 2-way communication between the CXM2 board and smart components like the communicating thermostat and diagnostic tool. The advanced CXM2 board uses information received from the temperature sensors to precisely control operation to deliver high efficiency, reliability and increased comfort.

**Diagnostics** – iGate 2 takes diagnosing water source heat pump units to a next level of simplicity, by providing a dashboard of system and fault information, in clear language, on the AWC Communicating Thermostat, handheld service tool and the web portal/mobile app on the internet.

iGate 2 Thermostat Service Warnings notify the homeowner and contractor of a fault and displays fault descriptions by app notifications/email with possible causes. Additionally, the current system status can be viewed graphically on the web portal and mobile app.

In iGate 2 Service Mode, the service personnel can access fault description, possible causes and most importantly, the conditions (temp, flow, i/o conditions, configuration) at the time of the fault. Manual Operation mode allows the service personnel to manually command operation for any of the thermostat outputs, blower speed, to help troubleshoot specific components. This operation can either be conducted at the unit with a communicating thermostat/diagnostic tool or remotely with mobile app/website when the AWC Communicating Thermostat controls are used.

With an iGate 2 communicating system, users and contractors have a web-enabled gateway to system information never before available and exclusive to ClimateMaster products.

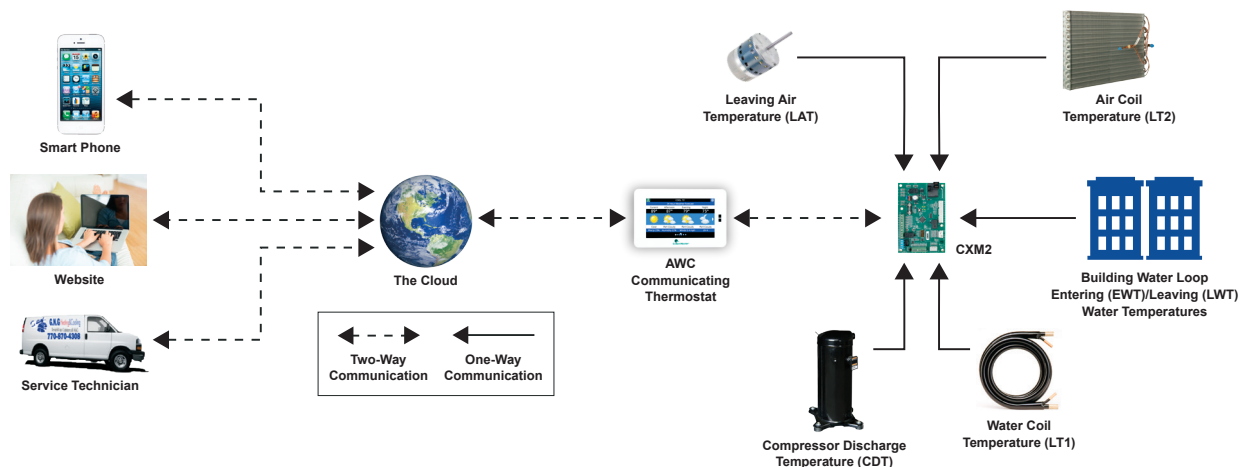

# iGate<sup>®</sup> 2 Communicating Controls Powered by DXM2.5

## iGate<sup>®</sup> 2 Communication – Cloud connected, web-enabled information gateway to monitor, control, and diagnose your system

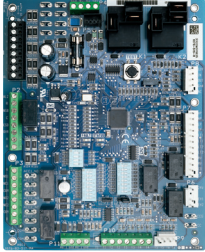

Tranquility<sup>®</sup> Vertical Stack (TSL) Series is equipped with industry-first, iGate<sup>®</sup> 2 communication information gateway that allows users to interact with their water-source system in easy to read clear language AND delivers improved reliability/efficiency by precisely controlling smart components.

**Monitor/Configure** – Installers can configure from the myUplink PRO website, mobile app, iGate 2 Communicating AWC Thermostat, or diagnostic tool, including: Airflow, unit family, size, accessory configuration, and demand reduction (optional, to limit unit operation during peak times). Users can look up the current system status: temperature sensor readings and operational status of the blower.

**Precise Control** – The new DXM2.5 board enables intelligent, 2-way communication between the DXM2.5 board and smart components like the communicating thermostat/diagnostic tool and constant volume (CV) EC fan motor. The advanced DXM2.5 board uses information received from the smart components and temperature sensors to precisely control operation of the variable speed CV EC fan to deliver higher efficiency, reliability and increased comfort.

**Diagnostics** – iGate 2 takes diagnosing water source heat pump units to a next level of simplicity, by providing a dashboard of system and fault information, in clear language, on the AWC Communicating Thermostat, handheld service tool and the web portal/mobile app on the internet.

iGate 2 Thermostat Service Warnings notify the homeowner and contractor of a fault and displays fault descriptions by app notifications/email with possible causes. Additionally, the current system status can be viewed graphically on the web portal and mobile app.

In iGate 2 Service Mode, the service personnel can access fault description, possible causes and most importantly, the conditions (temp, flow, i/o conditions, configuration) at the time of the fault. Manual Operation mode allows the service personnel to manually command operation for any of the thermostat outputs, blower speed, to help troubleshoot specific components. This operation can either be conducted at the unit with a communicating thermostat/diagnostic tool or remotely with mobile app/website when the AWC Communicating Thermostat controls are used.

With an iGate 2 communicating system, users and contractors have a web-enabled gateway to system information never before available and exclusive to ClimateMaster products.

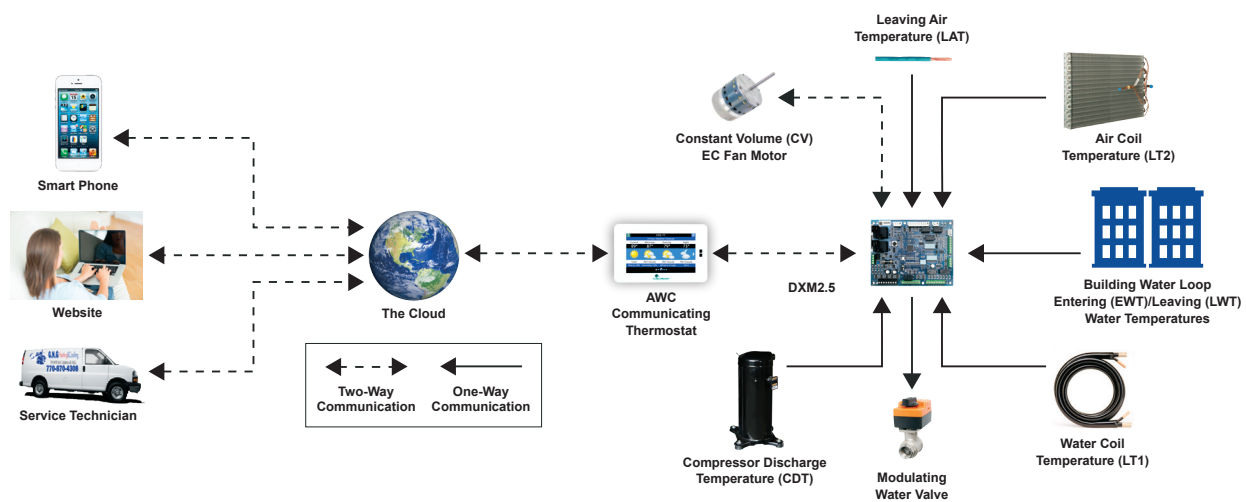

# iGate® 2 Communicating (AWC) Thermostat

## iGate® 2 Communication – Cloud connected, web-enabled information gateway to monitor, control, and diagnose your system

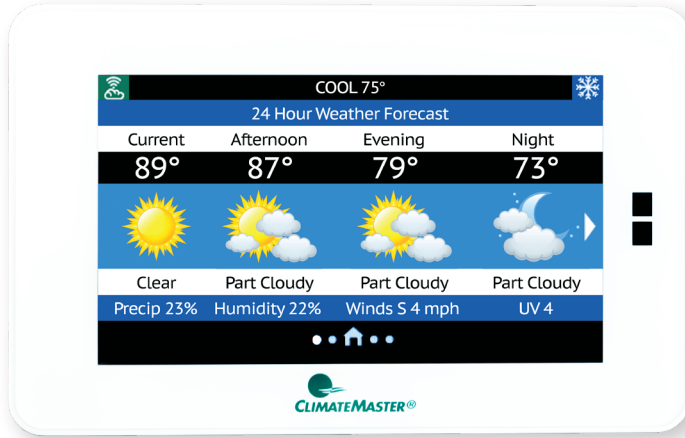

The iGate® 2 Communicating (AWC) Thermostat is innovating the future of comfort technology, one building at a time. The inspired design of the touch screen interface allows you to see real-time data for the efficiency and health of your system, with early warnings for potential system faults. The cloud based information gateway allows technicians to remotely diagnose system issues before occupants even know there is a problem. Control and monitor the system in your home or business from anywhere in the world with an easy to use app on your phone.

## Features with Efficiency in Mind



### Touch Screen Interface

A brilliantly customizable touch screen monitor for simple control.



### Seamless Integration

Between your iGate® 2 Communicating (AWC) Thermostat and Tranquility comfort system.



### (Mobile) Remote System Control

Control temperature and schedule from anywhere in the world.



### Early Fault Warnings

Alerts you and your contractor of potential system faults in the future.



### Remote Diagnostics

Enable the contractor to remotely diagnose system issues, adjust system settings, and reset faults.



### Real-Time Operations Data & System Schematics

Access simply via the myUplink Pro Account and web portal to view system diagrams with current operating temperatures.



### Revenue Stream

HVAC professionals can offer owners service contracts with remote monitoring and diagnosis capabilities without the large expense of a building management system.





## HVAC Professional | User Experience

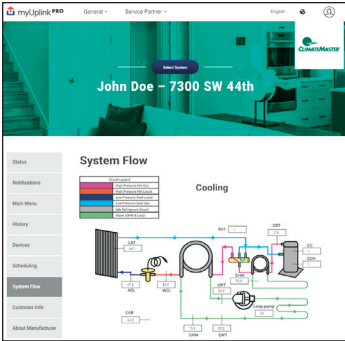

The iGate® 2 is more than just a smart thermostat for your residential or commercial customer, it's a business opportunity. Our new thermostat works with your customers' Tranquility comfort systems to provide the most efficient link between their system and

your services. The customization of monitoring from the myUplink PRO web portal or phone app account allows for continuous system monitoring, analysis, repair recognition, and early warnings for potential system faults that are sent to you and your customer.



### Benefits

- Remote login from anywhere, anytime from any internet connected device
- View system fault history with possible root causes
- Information is available for contractors to troubleshoot and diagnosis systems remotely
- Secure internet connection keeps homeowner information private
- Access thermostat(s) through Android and iPhone mobile apps

## Homeowner | User Experience

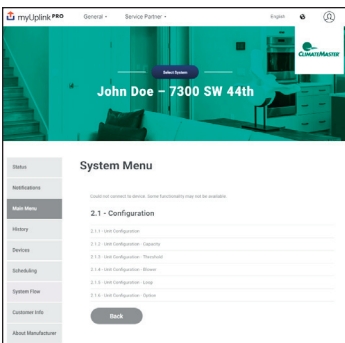

The iGate® 2 combines a Wi-Fi thermostat and advanced unit controls to communicate the systems operation information to the cloud. From any internet connected device or smart phone, homeowners can control and monitor their systems from anywhere in the

world. iGate 2 offers homeowners peace of mind their systems are operating at peak performance with advanced operational performance issue notifications. HVAC professionals get notifications when systems are operating out of range. They can log in remotely to check system faults, review current operating conditions, and diagnosis issues remotely. This gives the HVAC technician the upper hand when showing up to perform service, saving time which in turn saves money.



### Benefits

- Communicates personal settings and reminders through the iGate 2 communication system
- Easy-to-use, full-color, high-resolution interface
- Sleek, intuitive button control
- Secure internet connection keeps your information private
- Contains unit model, serial number and your HVAC professionals contact information
- System monitoring automatically contacts HVAC system providers when service is needed

# Constant Volume (CV) ECM

**The Intelligent Constant Volume (CV) ECM blower motor** provides unmatched functionality that saves installing and service technicians time while also providing increased comfort levels to occupants.

CV ECM's are programed to maintain a constant CFM across a wide range of external static pressures (ESP). This functionality differs from traditional PSC or even Constant Torque (CT) ECM's. With traditional PSC and CT ECM fan motors, as ESP is increased CFM is reduced. To increase or decrease the speed of the fan motor requires a fan motor switch or a technician to wire into a different motor tap. CT ECM's provide increased efficiency over PSC motors but with no additional functionality. With a CV ECM, as changes in ESP occur the fan motor will adjust its speed to deliver the desired CFM (within its operating range). This ensures the system is delivering the airflow and capacity it was designed for.

A major benefit of the CV ECM over other fan motor types its ability to adjust airflow remotely through the iGate® 2 web portal/mobile app or directly at the unit with a communicating diagnostic service tool or thermostat. Airflow levels can be adjusted in increments of 25 CFM from the units minimum and maximum CFM range (see CV ECM configuration table for details). This functionality allows technicians to dial in airflow during start-up and commissioning via an easy to use service tool. During operation occupants may have a desire for airflow adjustments. Reducing CFM can reduce airflow sound levels and increase cooling dehumidification (latent capacity). Technicians can easily make these adjustments without making wiring changes reducing service time with minimal disruption to the occupants.

The fan motor operating modes include:

- First Stage Cooling (Y1 & O)
- Second Stage Cooling (Y1, Y2, & O)
- First Stage Heating (Y1)
- Second Stage Heating (Y1 & Y2)
- Fan (G with no Y1, Y2, or W)

The CV ECM motor includes **“soft start”** and **“ramp down”** features. The soft start feature gently increases the motors rpm at blower start up resulting quieter blower start cycles. Likewise, the ramp down feature allows the blower to slowly decrease rpm to a full stop resulting in a quieter end to each blower cycle. The ramp down feature (also known as the heating or cooling “Off Delay”) also has the functionality to be field selected by the technician in the allowable range of 0 to 255 seconds.



**Airflow Configuration Screen on Mobile App**

# Constant Torque (CT) ECM

## The Constant Torque (CT) ECM blower

**motor** combines high efficient airflow movement with simplistic operation.

The CT ECM is designed to maintain a fixed RPM. The delivered unit airflow will depend on the total static applied on the system (ductwork, grilles, etc.). This is similar to the operation of a PSC motor and differs from the CV ECM motor which will adjust RPM to deliver a constant CFM. Also, like a traditional PSC blower motor, the CT ECM blower motor has 4-5 Speed Taps depending on unit size (see blower tables for details). The blower comes factory wired into two speed taps. To adjust speeds in the field a technician manually changes the electrical connection either at the fan motor or connecting wire harness (varies by size).

The blower offers a “soft start” feature. Soft start gently increases the blower motors rpm resulting in quieter operation during start up cycles. The blower does not include a “ramp down” feature like the CV ECM motor. When the fan call is removed the blower will immediately shut down. If the ramp down feature is required please select a CV ECM blower.

The CT ECM blower is not a communicating component and does not contain the high functionality like the CV ECM blower does. It offers an entry level ECM option for applications seeking high efficiency with simplistic functionality. Constant Volume (CV) and Constant Torque (CT) styles of ECM blower motors are both equally efficient in their operation. The difference between the two motors is in their operational functionality.



Speed Taps 1-5

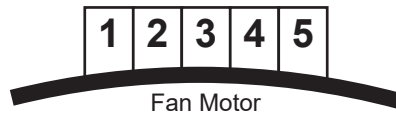



# vFlow<sup>®</sup> Modulating Water Valve

## vFlow<sup>®</sup> Internal Variable Water Flow

Industry-first, Built-in vFlow<sup>®</sup> provides an ultra-high-efficient internal water flow system. It saves installers time and labor by avoiding installing bulky valves or flow regulators in the field. Multi-unit installations are also much simpler with vFlow systems, as the units automatically adjust water flow across the system.

vFlow is enabled by iGate<sup>®</sup> 2, which facilitates intelligent communication between the thermostat, DXM2.5 control, sensors and modulating valve to make true variable water flow a reality.

In applications using the vFlow water flow control, when the motorized modulating valve slows down the external pump, consumes fewer watts, thus saving more energy.

## vFlow<sup>®</sup> delivers four main benefits:

1. One component replaces 2 way motorized valve and auto flow regulator
2. Superior reliability by varying the water flow to deliver more stable operation
3. Higher cost savings by varying water flow (and pump watt consumption) to match the unit's mode of operation
4. Allows unit to safely operate in cooling mode or heating mode from 20°F to 120°F

## Modulating Water Valve Operation:

When the unit is in cooling or heating, the DXM2.5 controller monitors the entering and leaving water temperature. Based on the desired water temperature differential (delta T), the DXM2.5 sends a voltage signal to the valve which correlates to a percentage open in order to achieve the water flow needed. As conditions change the voltage signal will readjust the valve for the needed water flow.

The modulating water valve is factory set for a water delta T of 10°F for cooling operation and 7°F for heating operation. This default setting is estimated to be approximately 3 GPM of water flow per ton of load capacity. Installers can change the water flow by adjusting the delta T upward for lower flow or downward for higher flow by using the communicating thermostat or service tool. Please see unit IOM for full instructions.

At low cooling EWT's and high heating EWT's the DXM2.5 software overrides the delta T settings and adjusts the valve to operate to a LWT of no less than 60°F for cooling and no greater than 70°F for heating.

Units with the modulating water valve will operate at EWT's from 30°F to 120°F in BOTH cooling and heating. When there is no demand for cooling or heating, the valve will be fully closed or can be field configured to remain slightly open allowing some water to pass through.

vFlow water flow controls are unmatched in the market and exclusive to ClimateMaster vertical stack products.

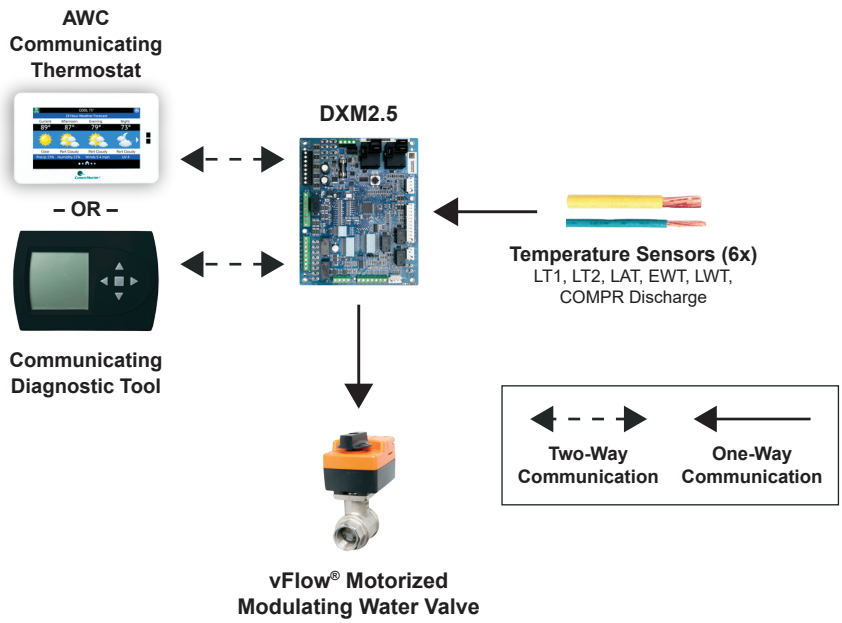

ClimateMaster works continually to improve its products. As a result, the design and specifications of each product at the time of order may be changed without notice and may not be as described herein. Please contact ClimateMaster's Customer Service Department at 1-405-745-6000 for specific information on the current design and specifications. Statements and other information contained herein are not express warranties and do not form the basis of any bargain between the parties, but are merely ClimateMaster's opinion or commendation of its products. The latest version of this document is available at [climatemaster.com](http://climatemaster.com). © ClimateMaster, Inc. All rights reserved 2014

# Selection Procedure

## Reference Calculations

HEATING	
$LWT = EWT - \frac{HE}{GPM \times Constant}$	
$LAT = EAT + \frac{HC}{CFM \times 1.08}$	

COOLING	
$LWT = EWT + \frac{HR}{GPM \times Constant}$	$LC = TC - SC$
$LAT (DB) = EAT (DB) - \frac{HC}{CFM \times 1.08}$	$S/T = \frac{SC}{TC}$

Constant = 500 for water, 485 for antifreeze

## Conversion Table - to convert inch-pound (English) to S-I (Metric)

Airflow	Water Flow	Est Static Pressure	Water Pressure Drop
Airflow (L/s) = CFM x 0.472	Water Flow (L/s) = gpm x 0.0631	ESP (Pa) = ESP (in of wg) x 249	PD (kPa) = PD (ft of hd) x 2.99

## Legend and Glossary of Abbreviations

Abbreviations	Descriptions
BTUH	BTU (British Thermal Unit) per hour
CDT	Compressor discharge temperature
CFM	Airflow, cubic feet per minute
COP	Coefficient of performance = BTUH output/BTUH input
CT ECM	Electronic commutated constant torque fan motor
CV ECM	Electronic commutated constant volume fan motor
DB	Dry bulb temperature, °F
EAT	Entering air temperature
EER	Energy efficient ratio = BTUH output/Watt input
ESP	External static pressure, inches w.g.
EWT	Entering water temperature
FPT	Female pipe thread
GPM	Water flow in U.S., gallons per minute
HC	Air heating capacity, BTUH
HE	Total heat of extraction, BTUH
HR	Total heat of rejection, BTUH
HWC	Hot water generator (desuperheater) capacity, Mbtuh
KW	Total power unit input, kilowatts
LAT	Leaving air temperature, °F
LC	Latent cooling capacity, BTUH
LOC	Loss of charge
LWT	Leaving water temperature, °F
MBTUH	1,000 BTU per hour
MPT	Male pipe thread
MWV	Motorized water valve
PSC	Permanent split capacitor
SC	Sensible cooling capacity, BTUH
S/T	Sensible to total cooling ratio
TC	Total cooling capacity, BTUH
TD or delta T	Temperature differential
VFD	Variable frequency drive
WB	Wet bulb temperature, °F
WPD	Waterside pressure drop, psi or feet of head
WSE	Waterside economizer

# Selection Procedure

- Step 1** Determine the actual heating and cooling loads at the desired dry bulb and wet bulb conditions.
- Step 2** Obtain the following design parameters: Entering water temperature, water flow rate in GPM, airflow in CFM, water flow pressure drop and design wet and dry bulb temperatures. Airflow CFM should be between 300 and 500 CFM per ton. Unit water pressure drop should be kept as close as possible to each other to make water balancing easier. Go to the appropriate tables and find the proper indicated water flow and water temperature.
- Step 3** Select a unit based on total and sensible cooling conditions. Select a unit which is closest to, but no larger than, the actual cooling load.
- Step 4** Enter tables at the design water flow and water temperature. Read the total and sensible cooling capacities (Note: interpolation is permissible, extrapolation is not).
- Step 5** Read the heating capacity. If it exceeds the design criteria it is acceptable. It is quite normal for Water-Source Heat Pumps to be selected on cooling capacity only since the heating output is usually greater than the cooling capacity.
- Step 6** Determine the correction factors associated with the variable factors of dry bulb, wet bulb, and air flow.  
  
 Corrected Total Cooling = tabulated total cooling x wet bulb correction x airflow correction.  
  
 Corrected Sensible Cooling = tabulated sensible cooling x wet/dry bulb correction, and air flow correction.
- Step 7** Compare the corrected capacities to the load requirements. Normally if the capacities are within 10% of the loads, the equipment is acceptable. It is better to under size than oversize, as undersizing improves humidity control, reduces sound levels and extends the life of the equipment.
- Step 8** When completed, calculate water temperature rise and assess the selection. If the units selected are not within 10% of the load calculations, then review what effect changing the GPM, water temperature and/or air flow and air temperature would have on the corrected capacities. If the desired capacity cannot be achieved, select the next larger or smaller unit and repeat the procedure. Remember, when in doubt, under size slightly for best performance.

## Example Equipment Selection For Cooling Step 1 Load Determination:

Assume we have determined that the appropriate cooling load at the desired dry bulb 80°F and wet bulb 65°F conditions is as follows

Total Cooling.....17,000 BTUH  
 Sensible Cooling.....12,000 BTUH  
 Entering Air Temp.....80°F Dry Bulb / 65°F Wet Bulb

## Step 2 Design Conditions:

Similarly, we have also obtained the following design parameters:

Entering Water Temp.....90°F  
 Water Flow (Based upon 10°F rise in temp.).....5.1 GPM  
 Airflow at ESP Unit.....630 CFM (90% of rated)

## Steps 3, 4 & 5 HP Selection:

After making our preliminary selection (TSL18 with PSC motor), we enter the tables at design water flow and water temperature and read Total Cooling, Sens. Cooling and Heat of Rej. capacities:

Total Cooling.....18,350 BTUH  
 Sensible Cooling.....13,210 BTUH  
 Heat of Rejection.....22,470 BTUH

## Steps 6 & 7 Entering Air and Airflow Corrections:

Next, we determine our correction factors.

	<u>Table</u>	<u>Ent Air</u>	<u>Airflow</u>	<u>Corrected</u>
Corrected Total Cooling =	18,350	x 0.975	x 0.971	= 17,372
Corrected Sens Cooling =	13,210	x 0.999	x 0.932	= 12,299
Corrected Heat of Reject =	22,470	x 0.982	x 0.979	= 21,602

## Step 8 Water Temperature Rise Calculation & Assessment:

Actual Temperature Rise.....8.8°F

When we compare the Corrected Total Cooling and Corrected Sensible Cooling figures with our load requirements stated in Step 1, we discover that our selection is within +/- 10% of our sensible load requirement. Furthermore, we see that our Corrected Total Cooling figure is slightly undersized as recommended, when compared to the actual indicated load.

# TSL Series Nomenclature – D Cabinet

Section	Position	Digit Value	Description
<b>Series</b>	1	D	Ducted Cabinet Series
<b>Size</b>	2	1	09 - 0.75 ton
		2	12 - 1 ton
		3	15 - 1.25 ton
		4	18 - 1.5 ton
		5	24 - 2 ton
		6	30 - 2.5 ton
		7	36 - 3 ton
<b>Voltage</b>	3	G	208-230/60/1
		E	265/60/1
<b>Options</b>	4	A	Premium Seal
		B	Stainless Steel Drain Pan
		C	Premium Seal & Stainless Steel Drain Pan
		0	None
		1	Premium Seal & 2" Filter
		2	Stainless Steel Drain Pan & 2" Filter
		3	Premium Seal, Stainless Steel Drain Pan, & 2" Filter
		4	2" Filter
<b>Harness Controls</b>	5	A	PSC fan motor, ADA mounted
		B	CV ECM fan motor, ADA mounted
		C	PSC fan motor, MPC DDC controls
		D	CV ECM fan motor, MPC DDC controls
		N	PSC fan motor, Remote mounted thermostat
		R	CV ECM fan motor, Remote mounted thermostat
		1	CT ECM fan motor, ADA mounted
		2	CT ECM fan motor, MPC DDC controls
		4	CT ECM fan motor, Remote mounted thermostat
		<b>Power Termination</b>	6
B	Breaker		
C	Breaker, Internal circulating pump		
D	Disconnect switch, Internal circulating pump		
E	Internal circulating pump		
0	None		
<b>Cabinet Height</b>	7		
		F	65" with isolation pad
<b>Riser Style</b>	8	0	Follower/None
		1	Standard
		2	Leader

Table Continue on Next Page



# TSL Series Nomenclature – D Cabinet

Table Continue from Previous Page

Section	Position	Digit Value	Description			
<b>Riser Location</b>	9	0	None			
		1	Shipped Separately			
		2	Left Back			
		3	Right Back			
		4	Left Side			
		5	Right Side			
		6	Chassis shipped in cabinet, risers shipped separately			
	7	Chassis shipped in cabinet, no risers, no ball valve assemblies				
<b>Riser Ball Valve Options</b>	10	5	Standard (MNPT) Ball Valves			
		N	None			
<b>Back/Front/Top Supply Air Locations</b>	11	E	Top			
<b>Side Supply Air Locations</b>	12	0	None			
<b>Misc. Cabinet Options</b>	13	<b>Option</b>	<b>Thermostat Whip</b>	<b>SA Opening</b>	<b>SA Dust Cover</b>	<b>RA Dust Cover</b>
		<b>A</b>	No Tstat Whip	Factory Configured	Yes	Yes
		<b>B</b>	15' Tstat Whip			
		<b>C</b>	25' Tstat Whip			
		<b>D</b>	35' Tstat Whip			
		<b>J</b>	No Tstat Whip	Factory Configured	Yes	None
		<b>K</b>	15' Tstat Whip			
		<b>L</b>	25' Tstat Whip			
		<b>M</b>	35' Tstat Whip			
		<b>N</b>	No Tstat Whip	Factory Configured	None	Yes
		<b>P</b>	15' Tstat Whip			
		<b>Q</b>	25' Tstat Whip			
		<b>R</b>	35' Tstat Whip			
		<b>4</b>	No Tstat Whip	Factory Configured	None	None
<b>5</b>	15' Tstat Whip					
<b>6</b>	25' Tstat Whip					
<b>7</b>	35' Tstat Whip					
<b>Type</b>	14	0	Standard			
<b>Revision</b>	15	D	Ducted Cabinet Series			

# TSL Hybrid Series Nomenclature – E Cabinet

Section	Position	Digit Value	Description
<b>Series</b>	1	E	Hybrid Cabinet Series
<b>Size</b>	2	1	09 - 0.75 ton
		2	12 - 1 ton
		3	15 - 1.25 ton
		4	18 - 1.5 ton
		5	24 - 2 ton
		6	30 - 2.5 ton
		7	36 - 3 ton
<b>Voltage</b>	3	G	208-230/60/1
		E	265/60/1
<b>Options</b>	4	A	Premium Seal
		B	Stainless Steel Drain Pan
		C	Premium Seal & Stainless Steel Drain Pan
		0	None
		1	Premium Seal & 2" Filter
		2	Stainless Steel Drain Pan & 2" Filter
		3	Premium Seal, Stainless Steel Drain Pan, & 2" Filter
		4	2" Filter
<b>Harness Controls</b>	5	B	CV ECM fan motor, ADA mounted
		D	CV ECM fan motor, MPC DDC controls
		R	CV ECM fan motor, Remote mounted thermostat
		S	CV ECM fan motor, Cabinet mounted thermostat
		1	CT ECM fan motor, ADA mounted
		2	CT ECM fan motor, MPC DDC controls
		4	CT ECM fan motor, Remote mounted thermostat
		5	CT ECM fan motor, Cabinet mounted thermostat
<b>Power Termination</b>	6	A	Disconnect switch
		B	Breaker
		C	Breaker, Internal circulating pump
		D	Disconnect switch, Internal circulating pump
		E	Internal circulating pump
		0	None
		<b>Cabinet Height</b>	7
B	80"		
C	88" with isolation pad		
D	80" with isolation pad		
E	65"		
F	65" with isolation pad		
<b>Riser Style</b>	8	0	Follower/None
		1	Standard
		2	Leader

Table Continue on Next Page

# TSL Hybrid Series Nomenclature – E Cabinet

Table Continue from Previous Page

Section	Position	Digit Value	Description
<b>Riser Location</b>	9	0	None
		1	Shipped Separately
		2	Left Back
		3	Right Back
		4	Left Side
		5	Right Side
		6	Chassis shipped in cabinet, risers shipped separately
	7	Chassis shipped in cabinet, no risers, no ball valve assemblies	
<b>Riser Ball Valve Options</b>	10	5	Standard (MNPT) Ball Valves
		N	None
<b>Back/Front/Top Supply Air Locations</b>	11	0	None
		A	Back Small
		B	Back Large
		C	Front Small
		D	Front Large
		E	Top
		F	Back Small & Top
		G	Back Large & Top
		H	Front Small & Top
		J	Front Large & Top
		K	Back Small & Front Small
		L	Back Large & Front Large
		M	Back Small & Front Large
		N	Back Large & Front Small
		P	Back Small, Front Small, & Top
		Q	Back Large, Front Large, & Top
R	Back Small, Front Large, & Top		
S	Back Large, Front Small, & Top		
<b>Side Supply Air Locations</b>	12	0	None
		A	Right Small
		B	Right Large
		C	Left Small
		D	Left Large
		E	Right Small & Left Small
		F	Right Large & Left Large
		G	Right Small & Left Large
H	Right Large & Left Small		

Table Continue on Next Page

# TSL Hybrid Series Nomenclature – E Cabinet

Table Continue from Previous Page

Section	Position	Digit Value	Description				
			Option	Thermostat Whip	SA Opening	SA Dust Cover	RA Dust Cover
Misc. Cabinet Options	13		A	No Tstat Whip	Factory Configured	Yes	Yes
			B	15' Tstat Whip			
			C	25' Tstat Whip			
			D	35' Tstat Whip			
			E	No Tstat Whip	Field Configured	None	Yes
			F	15' Tstat Whip			
			G	25' Tstat Whip			
			H	35' Tstat Whip			
			J	No Tstat Whip	Factory Configured	Yes	None
			K	15' Tstat Whip			
			L	25' Tstat Whip			
			M	35' Tstat Whip			
			N	No Tstat Whip	Factory Configured	None	Yes
			P	15' Tstat Whip			
			Q	25' Tstat Whip			
			R	35' Tstat Whip			
			0	No Tstat Whip	Field Configured	None	None
			1	15' Tstat Whip			
			2	25' Tstat Whip			
			3	35' Tstat Whip			
			4	No Tstat Whip	Factory Configured	None	None
5	15' Tstat Whip						
6	25' Tstat Whip						
7	35' Tstat Whip						
Type	14	0	Standard				
Revision	15	A	Hybrid Cabinet Series				



# TSL Series Nomenclature – Chassis

Section	Position	Digit Value	Description
<b>Series</b>	1-3	TSL	Vertical Stack Ducted & Hybrid Application
<b>Unit Size</b>	4-5	09	09 - 0.75 ton
		12	12 - 1 ton
		15	15 - 1.25 ton
		18	18 - 1.5 ton
		24	24 - 2 ton
		30	30 - 2.5 ton
		36	36 - 3 ton
<b>Voltage</b>	6	E	265/60/1
		G	208-230/60/1
<b>Chassis Options</b>	7	A	Stainless Steel Drain Pan
		B	UltraQuiet
		C	Stainless Steel Drain Pan & UltraQuiet
		D	Stainless Steel Drain Pan & Connection to communicating thermostat
		E	UltraQuiet & Connection to communicating thermostat
		F	Stainless Steel Drain Pan, UltraQuiet, & Connection to communicating thermostat
		G	Connection to communicating thermostat
		H	Stainless Steel Drain Pan & RIB Relay
		K	UltraQuiet & RIB Relay
		L	Stainless Steel Drain Pan, UltraQuiet, & RIB Relay
		M	RIB Relay
		N	Stainless Steel Drain Pan, RIB Relay, & Connection to communicating thermostat
		P	UltraQuiet, RIB Relay, & Connection to communicating thermostat
		Q	Stainless Steel Drain Pan, UltraQuiet, , RIB Relay, & Connection to communicating thermostat
		R	RIB Relay & Connection to communicating thermostat
		S	None
<b>Controls</b>	8	A	CXM2
		B	DXM2.5
		C	CXM2 w/MPC
		D	DXM2.5 w/MPC
<b>Auto-Flow Regulator</b>	9	C	1.5 GPM
		D	2 GPM
		E	2.5 GPM
		F	3 GPM
		G	3.5 GPM
		H	4 GPM
		J	5 GPM
		K	6 GPM
		L	7 GPM
		M	8 GPM
		N	9 GPM
		P	10.5 GPM
		S	None

**Table Continue on Next Page**

# TSL Series Nomenclature – Chassis

Table Continue from Previous Page

Section	Position	Digit Value	Description
<b>Water Circuit Options</b>	10	S	None
		M	2-Way Water Valve - Fail Closed
		N	2-Way Water Valve - Fail Opened
		G	3-Way Water Valve
		T	Modulating Water Valve
		P	Secondary Circulating Pump
		H	Hydronic Heating w/2-Way Water Valve - Fail Closed
		J	Hydronic Heating w/2-Way Water Valve - Fail Opened
		L	Hydronic Heating w/3-Way Water Valve
		K	Hydronic Heating w/ 3-Way Water Valve and Secondary Circulating Pump
<b>Heat Exchanger Options</b>	11	C	Tin-Plated Air Coil & Copper Water Coil
		N	Tin-Plated Air Coil & Cupro-Nickel Water Coil
		D	Tin-Plated Air Coil, Copper Water Coil, & Insulated Tubing
		E	Tin-Plated Air Coil, Cupro-Nickel Coil, & Insulated Tubing
		F	Standard Air Coil, Copper Water Coil, & Insulated Tubing
		G	Standard Air Coil, Cupro-Nickel Coil, & Insulated Tubing
		L	Standard Air Coil & Copper Water Coil
		M	Standard Air Coil, Cupro-Nickel Coil
<b>Shipping</b>	12	6	Chassis Ships in Cabinet (risers not attached)
		S	Standard
<b>Blower Motor</b>	13	A	PSC - Standard Static (TSL Only)
		C	Constant Torque ECM
		D	Constant Volume ECM
<b>Standard</b>	14	S	Standard
<b>Revision</b>	15	C	Current Revision

# TSL Series Accessory Nomenclature

## Return Air Panel "G" Style

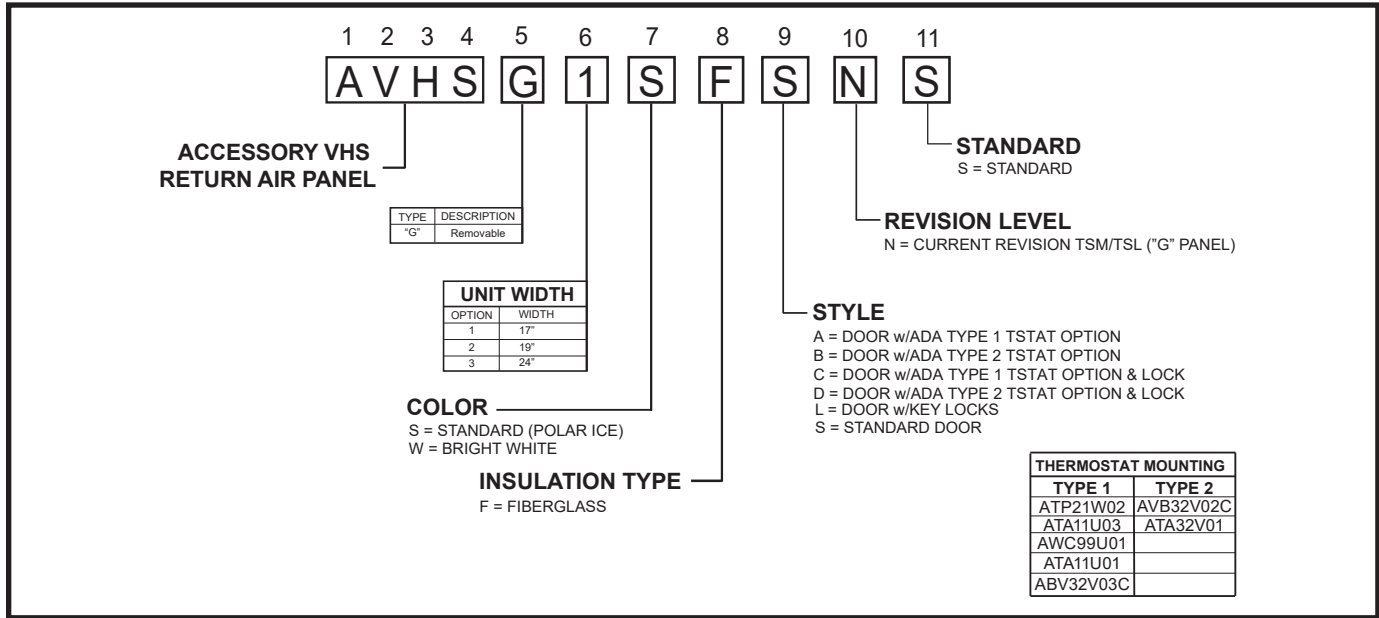

## Return Air Panel "L" Style

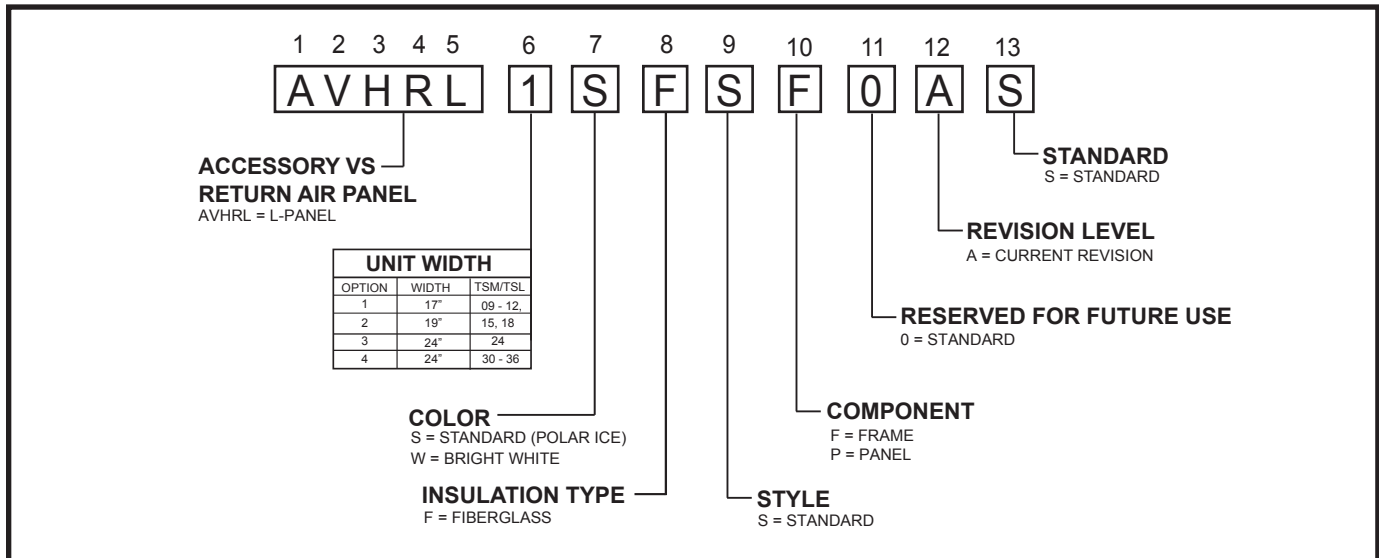

# TSL Series Accessory Nomenclature

## Riser

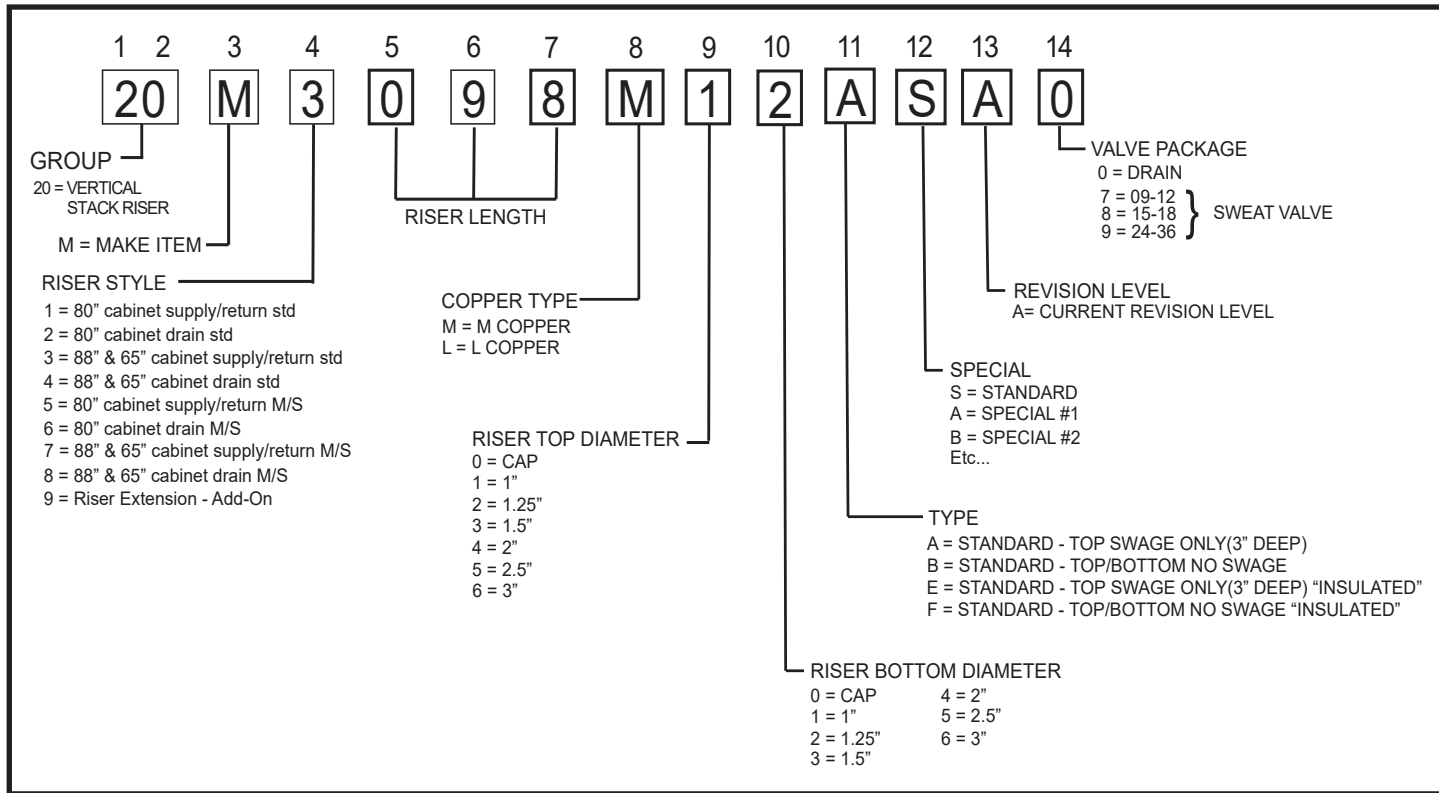

## Hose Kit

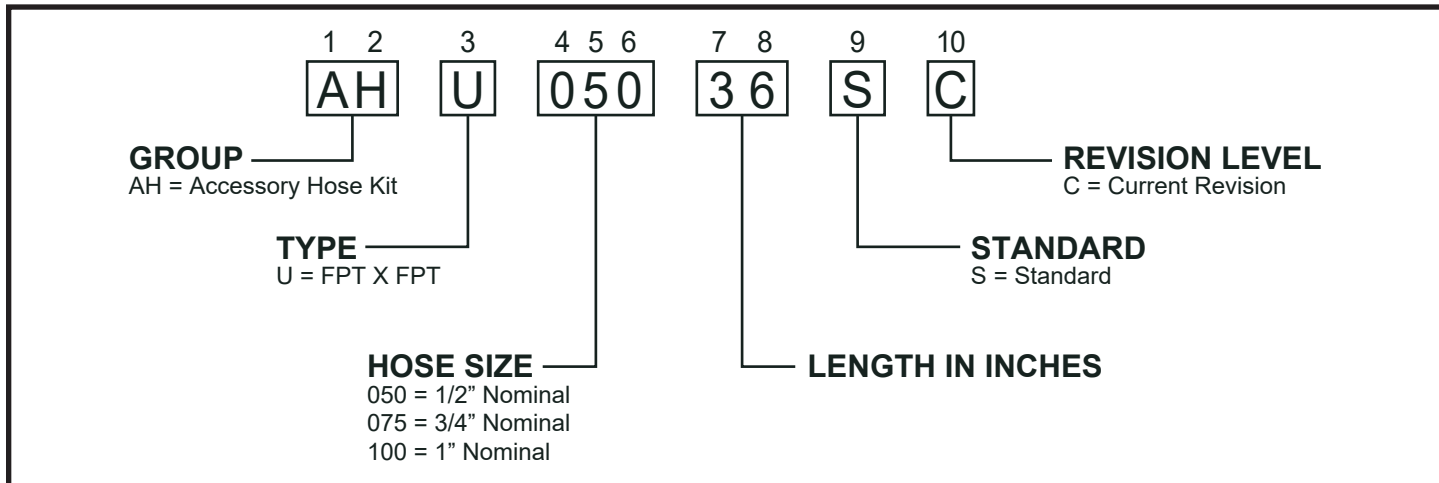



# TSL Series Accessory Nomenclature

## Cabinet Stands (Ship loose in bulk for field attachment)

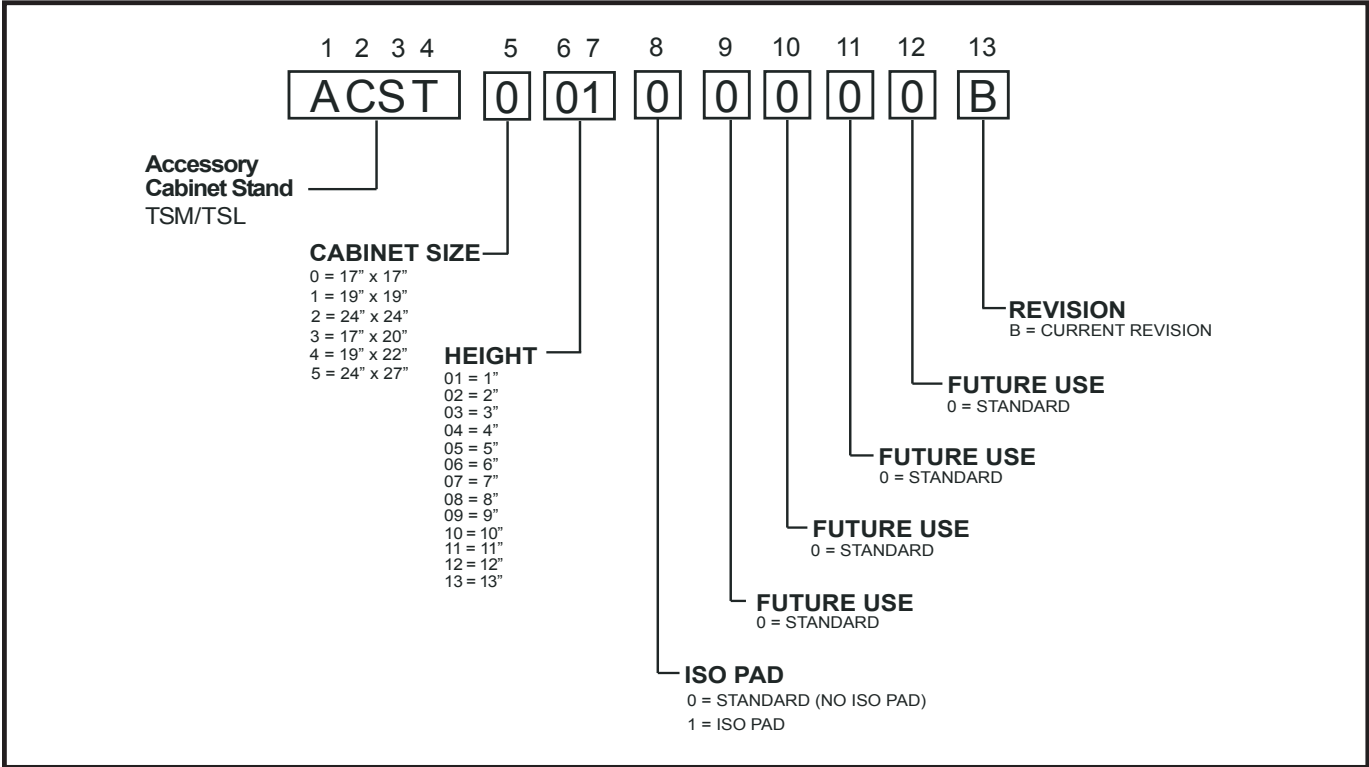

ClimateMaster works continually to improve its products. As a result, the design and specifications of each product at the time of order may be changed without notice and may not be as described herein. Please contact ClimateMaster's Customer Service Department at 1-405-745-6000 for specific information on the current design and specifications. Statements and other information contained herein are not express warranties and do not form the basis of any bargain between the parties, but are merely ClimateMaster's opinion or commendation of its products. The latest version of this document is available at [climatemaster.com](http://climatemaster.com). © ClimateMaster, Inc. All rights reserved 2014

# Performance Data – AHRI/ASHRAE/ISO 13256-1. English (I-P) Units

## AHRI/ASHRAE/ISO 13256-1. English (I-P) Units

Model with ECM Motor	Water Loop Heat Pump				Ground Loop Heat Pump			
	Cooling 86°F		Heating 68°F		Cooling 77°F		Heating 32°F	
	Capacity Btuh	EER Btuh/W	Capacity Btuh	COP	Capacity Btuh	EER Btuh/W	Capacity Btuh	COP
TSL09	9300	14.8	12500	5.6	10,100	16.8	7,200	3.4
TSL12	12000	15.4	15500	5.3	12,600	17.2	9,200	3.4
TSL15	14600	16.3	18900	5.4	15,400	19.2	11,000	3.7
TSL18	17100	15.1	22300	5.4	18,400	17.8	13,000	3.5
TSL24	25000	16.4	30500	5.3	26,500	19.4	18,500	3.6
TSL30	28500	16.1	33500	5.3	29,500	18.4	21,000	3.7
TSL36	35000	15.0	40500	5.0	36,000	16.7	25,500	3.5

Model with PSC Motor	Water Loop Heat Pump				Ground Loop Heat Pump			
	Cooling 86°F		Heating 68°F		Cooling 77°F		Heating 32°F	
	Capacity Btuh	EER Btuh/W	Capacity Btuh	COP	Capacity Btuh	EER Btuh/W	Capacity Btuh	COP
TSL09	9300	13.5	12500	5.2	10100	15.4	7200	3.2
TSL12	12000	14.2	15500	5.2	12600	15.9	9200	3.2
TSL15	14000	14.3	19000	5.0	15400	17.7	11500	3.6
TSL18	16800	13.2	22800	5.0	18600	16.9	13100	3.4
TSL24	24500	15.2	31500	5.0	26000	17.9	18500	3.4
TSL30	28000	15.2	34000	5.2	29500	18.0	21000	3.4
TSL36	35000	14.3	40500	5.0	36000	16.6	25500	3.5

## TSL Hybrid Series – English

Model with ECM Motor	Hydronic Heating Entering Air 70°			
	CFM	EWT (°F)	GPM	Capacity Btuh
TSL09	400	105	2.25	10200
TSL12	500	105	3.00	12400
TSL15	700	105	3.75	17000
TSL18	800	105	4.50	19300
TSL24	950	105	6.00	25700
TSL30	1150	105	7.50	31100
TSL36	1350	105	9.00	36000

# Performance Data – AHRI/ASHRAE/ISO 13256-1. Metric (S-I) Units

## AHRI/ASHRAE/ISO 13256-1. Metric (S-I) Units

Model with ECM Motor	Water Loop Heat Pump				Ground Loop Heat Pump			
	Cooling 30°C		Heating 20°C		Cooling 25°C		Heating 0°C	
	Capacity kW	EER W/W	Capacity kW	COP	Capacity kW	EER W/W	Capacity kW	COP
TSL09	2.73	4.3	3.67	5.6	2.96	4.9	2.11	3.4
TSL12	3.52	4.5	4.55	5.3	3.70	5.0	2.70	3.4
TSL15	4.28	4.8	5.54	5.4	4.52	5.6	3.23	3.7
TSL18	5.01	4.4	6.54	5.4	5.40	5.2	3.81	3.5
TSL24	7.33	4.8	8.94	5.3	7.77	5.7	5.43	3.6
TSL30	8.36	4.7	9.82	5.3	8.65	5.4	6.16	3.7
TSL36	10.26	4.4	11.88	5.0	10.56	4.9	7.48	3.5

Model with PSC Motor	Water Loop Heat Pump				Ground Loop Heat Pump			
	Cooling 30°C		Heating 20°C		Cooling 25°C		Heating 0°C	
	Capacity kW	EER W/W	Capacity kW	COP	Capacity kW	EER W/W	Capacity kW	COP
TSL09	2.73	4.0	3.67	5.2	2.96	4.5	2.11	3.2
TSL12	3.52	4.2	4.55	5.2	3.70	4.7	2.70	3.2
TSL15	4.11	4.2	5.57	5.0	4.52	5.2	3.37	3.6
TSL18	4.93	3.9	6.69	5.0	5.45	5.0	3.84	3.4
TSL24	7.18	4.5	9.24	5.0	7.62	5.2	5.43	3.4
TSL30	8.21	4.5	9.97	5.2	8.65	5.3	6.16	3.4
TSL36	10.26	4.2	11.88	5.0	10.56	4.9	7.48	3.5

Cooling capacities based upon 27°C DB, 19°C WB entering air temperature  
 Heating capacities based upon 20°C DB, 15°C WB entering air temperature  
 All units AHRI/ISO/ASHRAE 13256-1 rated on high speed motor TAP  
 All ratings based upon operation at lower voltage of dual voltage rated models

## TSL Hybrid Series – Metric

Model with ECM Motor	Hydronic Heating Entering Air 21.1°C			
	CFM	EWT (°C)	l/m	Capacity kW
TSL09	400	40.6	8.52	3.0
TSL12	500	40.6	11.36	3.6
TSL15	700	40.6	14.19	5.0
TSL18	800	40.6	17.03	5.7
TSL24	950	40.6	22.71	7.5
TSL30	1150	40.6	28.39	9.1
TSL36	1350	40.6	34.07	10.6

## Performance Data – Selection Notes

For operation in the shaded area to determine if water can be used in lieu of an antifreeze solution, the Leaving Water Temperature (LWT) must be calculated. Flow must be maintained to a level such that the LWT is maintained above 42°F [5.6°C] when the CXM2/DXM2.5 JW3 jumper is not clipped (see example below). Otherwise, appropriate levels (10° below LWT, See IOM) of a proper antifreeze should be used in systems with leaving water temperatures of 42°F [5.6°C] or below and the JW3 jumper should be clipped. This is due to the potential of the refrigerant temperature being as low as 32°F [0°C], which may lead to a nuisance cutout due to the activation of the Low Temperature Protection (LT1). JW3 should **never** be clipped for standard range equipment or systems without antifreeze.

### Example:

At 50°F EWT (Entering Water Temperature) and 1.5 gpm/ton, a 3 ton unit has a HE of 26,830 Btuh. To calculate LWT, rearrange the formula for HE as follows:

HE = TD x GPM x 500, where HE = Heat of Extraction (Btuh);  
TD = temperature difference (EWT - LWT) and GPM = U.S. Gallons per Minute.

$$TD = HE / (GPM \times 500)$$

$$TD = 26,830 / (4.5 \times 500)$$

$$TD = 12^\circ\text{F}$$

$$LWT = EWT - TD$$

LWT = 50 - 12 = 38°F - Requires appropriate antifreeze (Protect to 28°F), JW3 must be clipped, and extended range insulation option.

In this example, a higher flow rate will be required for EWTs of 50°F without antifreeze. At 3 gpm/ton, the calculation becomes:

(Note higher flow increases HE)

$$TD = 29,650 / (9\text{GPM} \times 500)$$

$$TD = 7^\circ\text{F}$$

LWT = 50 - 7 = 43°F - Water is acceptable, do not clip JW3.

		Heating - EAT 70°F					
Model	EER	HC	kW	HE	LAT	COP	
Standard							
Standard	23.28	2.31	15.72	85.9	3.0		
2	52.07	29.0	26.08	2.35	18.36	88.1	3.2
1	52.26	31.3	27.35	2.37	19.56	89.1	3.4
7	52.27	32.5	28.06	2.38	20.23	89.6	3.4
	51.56	26.0	30.51	2.42	22.56	91.5	3.7
	51.98	28.3	32.12	2.45	24.08	92.7	3.8
	52.12	29.4	33.01	2.46	24.92	93.4	3.9
	52	22.9	35.03	2.49	<del>26.83</del>	95.0	4.1
		25.3	36.94	2.52	28.65	96.4	4.3
		27.4	38.00	2.54	<u>29.65</u>	97.3	4.4
		29.5	39.53	2.56	31.09	98.4	4.5



# Performance Data – TSL09 with PSC Motor

## 400 CFM Nominal Airflow

Performance capacities shown in thousands of Btu/h

EWT °F	GPM	WPD*		Cooling - EAT 80/67°F						Heating - EAT 70°F				
		PSI	FT	TC	SC	Sens/Tot Ratio	kW	HR	EER	HC	kW	HE	LAT	COP
20	1.13	1.6	3.6	Operation not recommended						5.7	0.64	3.5	83.1	2.6
	1.69	3.0	6.9											
	2.25	4.9	11.3											
30	1.13	1.2	2.8	12.2	9.0	0.74	0.53	14.1	23.2	6.4	0.65	4.2	84.9	2.9
	1.69	2.7	6.2	12.2	8.8	0.72	0.50	13.9	24.4	6.8	0.65	4.5	85.6	3.0
	2.25	4.5	10.3	12.0	8.5	0.71	0.49	13.7	24.7	6.9	0.65	4.7	86.0	3.1
40	1.13	1.0	2.4	12.0	9.1	0.75	0.57	14.0	21.0	7.6	0.66	5.4	87.6	3.4
	1.69	1.9	4.5	12.2	9.0	0.74	0.54	14.1	22.8	8.0	0.66	5.8	88.5	3.5
	2.25	3.1	7.3	12.3	9.0	0.73	0.52	14.0	23.6	8.3	0.67	6.0	89.1	3.6
50	1.13	1.0	2.2	11.6	8.9	0.77	0.63	13.7	18.5	8.8	0.67	6.5	90.4	3.9
	1.69	1.9	4.3	12.0	9.0	0.75	0.58	14.0	20.6	9.3	0.68	7.0	91.6	4.1
	2.25	3.1	7.1	12.1	9.1	0.75	0.56	14.0	21.6	9.6	0.68	7.3	92.3	4.2
60	1.13	0.9	2.1	11.0	8.6	0.78	0.68	13.3	16.0	10.1	0.68	7.7	93.2	4.3
	1.69	1.8	4.2	11.5	8.8	0.77	0.64	13.6	18.0	10.7	0.69	8.4	94.7	4.6
	2.25	3.0	6.9	11.7	8.9	0.76	0.61	13.8	19.1	11.1	0.69	8.7	95.6	4.7
70	1.13	0.8	1.9	10.2	8.1	0.80	0.75	12.8	13.7	11.3	0.69	9.0	96.2	4.8
	1.69	1.8	4.1	10.8	8.5	0.78	0.70	13.2	15.5	12.1	0.70	9.7	97.9	5.1
	2.25	2.9	6.7	11.1	8.6	0.78	0.67	13.4	16.5	12.5	0.70	10.1	98.9	5.2
80	1.13	0.8	1.8	9.4	7.7	0.82	0.81	12.2	11.6	12.6	0.70	10.2	99.1	5.3
	1.69	1.7	3.9	10.0	8.0	0.80	0.76	12.6	13.1	13.5	0.71	11.1	101.1	5.6
	2.25	2.8	6.5	10.3	8.2	0.79	0.74	12.8	14.0	14.0	0.71	11.5	102.2	5.8
90	1.13	0.7	1.7	8.6	7.2	0.84	0.88	11.6	9.7	13.9	0.71	11.5	102.1	5.8
	1.69	1.6	3.8	9.2	7.5	0.82	0.83	12.0	11.0	14.8	0.71	12.4	104.3	6.1
	2.25	2.8	6.4	9.5	7.7	0.81	0.81	12.2	11.8	15.4	0.72	12.9	105.5	6.3
100	1.13	0.7	1.7	7.7	6.7	0.87	0.95	11.0	8.1	14.0	0.71	11.5	102.2	5.8
	1.69	1.6	3.7	8.3	7.0	0.85	0.90	11.4	9.2	14.0	0.71	11.5	102.2	5.8
	2.25	2.7	6.2	8.6	7.2	0.84	0.88	11.6	9.8	14.0	0.71	11.5	102.2	5.8
110	1.13	0.7	1.6	6.9	6.3	0.91	1.02	10.4	6.8	14.0	0.71	11.5	102.2	5.8
	1.69	1.6	3.6	7.4	6.6	0.88	0.98	10.8	7.6	14.0	0.71	11.5	102.2	5.8
	2.25	2.6	6.1	7.7	6.7	0.87	0.95	11.0	8.1	14.0	0.71	11.5	102.2	5.8
120	1.13	0.7	1.6	6.2	6.0	0.96	1.10	10.0	5.7	14.0	0.71	11.5	102.2	5.8
	1.69	1.5	3.5	6.6	6.2	0.93	1.05	10.2	6.3	14.0	0.71	11.5	102.2	5.8
	2.25	2.6	5.9	6.9	6.3	0.91	1.03	10.4	6.7	14.0	0.71	11.5	102.2	5.8

Interpolation is permissible, extrapolation is not.

All entering air conditions are 80°F DB and 67°F WB in cooling and 70°F DB in heating.

All performance data is based upon the lower voltage of dual voltage rated units.

See performance correction tables for operating conditions other than those listed above.

Table does not reflect corrections for Fan and Pump watts used is ISO-13256.

Operation below 40°F EWT is based upon 20% methanol antifreeze solution.

All performance data is based upon High speed.

Operation below 60°F requires optional insulated water/refrigerant circuit.

Operation in the darker shaded region is only permissible with use of ClimateMaster Modulating Water valve. At these conditions, water flow will be reduced in order to maintain a leaving water temperature of 70°F

Operation in the lighter shaded areas may require antifreeze. See Performance Data Selection Notes for operation in the lighter shaded areas.

# Performance Data – TSL12 with PSC Motor

## 450 CFM Nominal Airflow

Performance capacities shown in thousands of Btu/h

EWT °F	GPM	WPD*		Cooling - EAT 80/67°F						Heating - EAT 70°F				
		PSI	FT	TC	SC	Sens/Tot Ratio	kW	HR	EER	HC	kW	HE	LAT	COP
20	1.50	2.3	5.3	Operation not recommended						7.6	0.87	4.7	85.7	2.6
	2.25	4.7	10.8											
	3.00	7.8	18.0											
30	1.50	2.1	4.7	14.5	9.7	0.67	0.63	16.6	23.0	8.8	0.89	5.8	88.1	2.9
	2.25	4.3	9.9	14.3	9.3	0.65	0.60	16.3	23.6	9.3	0.89	6.3	89.1	3.0
	3.00	7.0	16.2	14.0	9.0	0.64	0.60	16.1	23.6	9.6	0.90	6.5	89.6	3.1
40	1.50	1.5	3.6	14.4	10.0	0.69	0.68	16.7	21.2	10.5	0.91	7.4	91.6	3.4
	2.25	3.1	7.3	14.5	9.8	0.67	0.64	16.7	22.6	11.1	0.92	8.0	92.8	3.5
	3.00	5.2	12.1	14.5	9.6	0.67	0.62	16.6	23.2	11.4	0.92	8.3	93.4	3.6
50	1.50	1.5	3.5	14.0	9.9	0.71	0.74	16.6	18.9	12.1	0.93	9.0	94.9	3.8
	2.25	3.1	7.1	14.4	10.0	0.69	0.69	16.7	20.7	12.8	0.94	9.6	98.4	4.0
	3.00	5.1	11.8	14.5	9.9	0.69	0.67	16.8	21.5	13.2	0.94	10.0	97.2	4.1
60	1.50	1.5	3.4	13.4	9.7	0.73	0.82	16.2	16.4	13.8	0.95	10.5	98.3	4.2
	2.25	3.0	6.9	13.9	9.9	0.71	0.76	16.5	18.3	14.6	0.96	11.3	100.0	4.4
	3.00	5.0	11.4	14.1	10.0	0.71	0.73	16.6	19.2	15.1	0.97	11.8	100.9	4.6
70	1.50	1.4	3.3	12.6	9.4	0.75	0.89	15.6	14.1	15.4	0.97	12.1	101.6	4.6
	2.25	2.9	6.7	13.2	9.7	0.73	0.84	16.0	15.8	16.4	0.98	13.0	103.6	4.9
	3.00	4.8	11.1	13.5	9.8	0.73	0.81	16.2	16.7	16.9	0.99	13.5	104.7	5.0
80	1.50	1.4	3.2	11.7	9.0	0.77	0.98	15.0	11.9	17.1	0.99	13.7	105.0	5.0
	2.25	2.8	6.5	12.3	9.3	0.75	0.92	15.5	13.4	18.2	1.01	14.8	107.4	5.3
	3.00	4.7	10.8	12.6	9.4	0.75	0.89	15.7	14.2	18.8	1.01	15.4	108.7	5.5
90	1.50	1.3	3.1	10.7	8.4	0.79	1.06	14.3	10.0	18.8	1.01	15.3	108.6	5.4
	2.25	2.8	6.4	11.3	8.8	0.77	1.01	14.8	11.3	20.1	1.03	16.6	111.3	5.7
	3.00	4.6	10.5	11.7	9.0	0.77	0.98	15.0	12.0	20.9	1.04	17.3	112.9	5.9
100	1.50	1.3	3.0	9.7	7.9	0.82	1.15	13.6	8.4	18.8	1.01	15.4	108.7	5.5
	2.25	2.7	6.2	10.3	8.3	0.80	1.10	14.1	9.4	18.8	1.01	15.4	108.7	5.5
	3.00	4.5	10.3	10.7	8.4	0.79	1.07	14.3	10.0	18.8	1.01	15.4	108.7	5.5
110	1.50	1.3	2.9	8.7	7.4	0.85	1.24	12.9	7.0	18.8	1.01	15.4	108.7	5.5
	2.25	2.6	6.1	9.3	7.7	0.83	1.19	13.3	7.8	18.8	1.01	15.4	108.7	5.5
	3.00	4.4	10.1	9.6	7.9	0.82	1.16	13.6	8.3	18.8	1.01	15.4	108.7	5.5
120	1.50	1.2	2.8	7.8	6.9	0.88	1.33	12.3	5.9	18.8	1.01	15.4	108.7	5.5
	2.25	2.6	5.9	8.3	7.2	0.86	1.28	12.7	6.5	18.8	1.01	15.4	108.7	5.5
	3.00	4.3	10.0	8.6	7.3	0.85	1.25	12.9	6.8	18.8	1.01	15.4	108.7	5.5

Interpolation is permissible, extrapolation is not.

All entering air conditions are 80°F DB and 67°F WB in cooling and 70°F DB in heating.

All performance data is based upon the lower voltage of dual voltage rated units.

See performance correction tables for operating conditions other than those listed above.

Table does not reflect corrections for Fan and Pump watts used is ISO-13256.

Operation below 40°F EWT is based upon 20% methanol antifreeze solution.

All performance data is based upon High speed.

Operation below 60°F requires optional insulated water/refrigerant circuit.

Operation in the darker shaded region is only permissible with use of ClimateMaster Modulating Water valve. At these conditions, water flow will be reduced in order to maintain a leaving water temperature of 70°F

Operation in the lighter shaded areas may require antifreeze. See Performance Data Selection Notes for operation in the lighter shaded areas.

# Performance Data – TSL15 with PSC Motor

## 600 CFM Nominal (Rated) Airflow

Performance capacities shown in thousands of Btu/h

EWT °F	GPM	WPD*		Cooling - EAT 80/67°F						Heating - EAT 70°F				
		PSI	FT	TC	SC	Sens/Tot Ratio	kW	HR	EER	HC	kW	HE	LAT	COP
20	1.88	0.8	1.8	Operation not recommended						9.1	0.99	5.7	84.0	2.7
	2.81	1.6	3.8											
	3.75	2.7	6.3											
30	1.88	0.6	1.5	18.9	13.9	0.73	0.65	21.1	28.8	10.4	1.02	7.0	86.1	3.0
	2.81	1.4	3.2	18.5	12.9	0.70	0.62	20.6	29.9	11.0	1.02	7.5	86.9	3.1
	3.75	2.3	5.4	18.1	12.2	0.68	0.61	20.1	29.8	11.3	1.03	7.8	87.4	3.2
40	1.88	0.4	1.0	18.8	14.4	0.77	0.72	21.2	26.0	12.5	1.05	8.9	89.2	3.5
	2.81	0.9	2.1	18.9	14.0	0.74	0.67	21.2	28.3	13.2	1.05	9.6	90.3	3.7
	3.75	1.5	3.5	18.8	13.7	0.73	0.65	21.0	29.1	13.6	1.06	10.0	90.9	3.8
50	1.88	0.4	0.9	18.2	14.2	0.78	0.81	20.9	22.5	14.5	1.07	10.9	92.4	4.0
	2.81	0.9	2.0	18.7	14.4	0.77	0.74	21.2	25.2	15.5	1.08	11.8	93.8	4.2
	3.75	1.4	3.3	18.8	14.3	0.76	0.71	21.2	26.5	16.0	1.09	12.3	94.6	4.3
60	1.88	0.4	0.9	17.2	13.7	0.80	0.90	20.3	19.0	16.7	1.09	13.0	95.7	4.5
	2.81	0.8	1.9	17.9	14.1	0.79	0.83	20.8	21.6	17.8	1.10	14.0	97.4	4.7
	3.75	1.4	3.2	18.3	14.3	0.78	0.80	21.0	23.0	18.4	1.11	14.6	98.3	4.9
70	1.88	0.4	0.8	16.0	12.9	0.81	1.01	19.5	15.9	18.9	1.11	15.1	99.0	5.0
	2.81	0.8	1.8	16.9	13.5	0.80	0.93	20.1	18.1	20.1	1.12	16.3	101.0	5.3
	3.75	1.3	3.0	17.3	13.8	0.79	0.89	20.4	19.4	20.8	1.13	17.0	102.1	5.4
80	1.88	0.3	0.8	14.7	12.1	0.82	1.12	18.6	13.1	21.0	1.13	17.1	102.3	5.5
	2.81	0.7	1.7	15.6	12.7	0.81	1.04	19.2	15.0	22.4	1.14	18.5	104.5	5.8
	3.75	1.3	2.9	16.1	13.0	0.81	1.00	19.5	16.0	23.2	1.14	19.3	105.7	5.9
90	1.88	0.3	0.8	13.4	11.2	0.84	1.24	17.7	10.8	23.1	1.14	19.2	105.5	5.9
	2.81	0.7	1.7	14.3	11.8	0.82	1.16	18.3	12.3	24.6	1.15	20.7	107.9	6.3
	3.75	1.2	2.8	14.8	12.1	0.82	1.12	18.6	13.1	25.4	1.16	21.5	109.1	6.4
100	1.88	0.3	0.7	12.2	10.5	0.87	1.37	16.8	8.9	23.2	1.14	19.3	105.7	5.9
	2.81	0.7	1.6	12.9	11.0	0.85	1.29	17.3	10.0	23.2	1.14	19.3	105.7	5.9
	3.75	1.2	2.7	13.4	11.2	0.84	1.25	17.6	10.7	23.2	1.14	19.3	105.7	5.9
110	1.88	0.3	0.7	11.0	10.0	0.91	1.49	16.1	7.4	23.2	1.14	19.3	105.7	5.9
	2.81	0.7	1.5	11.7	10.3	0.88	1.42	16.5	8.2	23.2	1.14	19.3	105.7	5.9
	3.75	1.1	2.6	12.0	10.5	0.87	1.38	16.7	8.7	23.2	1.14	19.3	105.7	5.9
120	1.88	0.3	0.7	10.2	9.9	0.97	1.62	15.7	6.3	23.2	1.14	19.3	105.7	5.9
	2.81	0.6	1.5	10.6	9.9	0.93	1.55	15.9	6.9	23.2	1.14	19.3	105.7	5.9
	3.75	1.1	2.5	10.9	10.0	0.92	1.51	16.0	7.2	23.2	1.14	19.3	105.7	5.9

Interpolation is permissible, extrapolation is not.

All entering air conditions are 80°F DB and 67°F WB in cooling and 70°F DB in heating.

All performance data is based upon the lower voltage of dual voltage rated units.

See performance correction tables for operating conditions other than those listed above.

Table does not reflect corrections for Fan and Pump watts used is ISO-13256.

Operation below 40°F EWT is based upon 20% methanol antifreeze solution.

All performance data is based upon High speed.

Operation below 60°F requires optional insulated water/refrigerant circuit.

Operation in the darker shaded region is only permissible with use of ClimateMaster Modulating Water valve. At these conditions, water flow will be reduced in order to maintain a leaving water temperature of 70°F

Operation in the lighter shaded areas may require antifreeze. See Performance Data Selection Notes for operation in the lighter shaded areas.

# Performance Data – TSL18 with PSC Motor

## 700 CFM Nominal (Rated) Airflow

Performance capacities shown in thousands of Btuh

EWT °F	GPM	WPD*		Cooling - EAT 80/67°F						Heating - EAT 70°F				
		PSI	FT	TC	SC	Sens/Tot Ratio	kW	HR	EER	HC	kW	HE	LAT	COP
20	2.25	0.8	1.8	Operation not recommended						10.2	1.16	6.2	83.4	2.6
	3.38	1.9	4.4											
	4.50	3.3	7.7											
30	2.25	0.6	1.4	20.4	14.1	0.69	0.82	23.2	25.1	12.1	1.19	8.0	85.9	3.0
	3.38	1.6	3.7	20.2	13.6	0.67	0.77	22.9	26.4	12.8	1.20	8.7	86.8	3.1
	4.50	2.8	6.6	20.0	13.2	0.66	0.75	22.6	26.8	13.1	1.21	9.0	87.3	3.2
40	2.25	0.5	1.1	20.2	14.3	0.71	0.90	23.2	22.5	14.6	1.23	10.4	89.3	3.5
	3.38	1.2	2.7	20.4	14.2	0.70	0.84	23.3	24.4	15.4	1.24	11.2	90.3	3.6
	4.50	2.0	4.7	20.4	14.1	0.69	0.81	23.2	25.2	15.9	1.25	11.6	90.9	3.7
50	2.25	0.4	1.0	19.5	14.1	0.73	0.99	22.8	19.6	17.0	1.26	12.7	92.4	3.9
	3.38	1.1	2.6	20.0	14.3	0.71	0.92	23.2	21.7	17.9	1.27	13.6	93.6	4.1
	4.50	2.0	4.5	20.2	14.3	0.71	0.89	23.3	22.7	18.4	1.28	14.0	94.3	4.2
60	2.25	0.4	1.0	18.4	13.7	0.74	1.10	22.2	16.8	19.2	1.28	14.8	95.3	4.4
	3.38	1.1	2.5	19.2	14.0	0.73	1.02	22.7	18.7	20.2	1.29	15.8	96.7	4.6
	4.50	1.9	4.3	19.5	14.1	0.72	0.99	22.9	19.8	20.8	1.30	16.3	97.4	4.7
70	2.25	0.4	0.9	17.1	13.0	0.76	1.22	21.3	14.1	21.3	1.31	16.9	98.1	4.8
	3.38	1.0	2.4	18.0	13.5	0.75	1.14	21.9	15.9	22.4	1.32	17.9	99.6	5.0
	4.50	1.8	4.1	18.4	13.7	0.74	1.10	22.2	16.8	23.0	1.32	18.5	100.4	5.1
80	2.25	0.4	0.9	15.7	12.3	0.78	1.34	20.3	11.7	23.4	1.33	18.8	100.8	5.2
	3.38	1.0	2.2	16.6	12.8	0.77	1.26	20.9	13.2	24.6	1.34	20.0	102.4	5.4
	4.50	1.7	4.0	17.1	13.0	0.76	1.22	21.3	14.0	25.2	1.35	20.6	103.3	5.5
90	2.25	0.4	0.8	14.2	11.6	0.81	1.48	19.3	9.6	25.3	1.35	20.7	103.5	5.5
	3.38	0.9	2.1	15.1	12.0	0.79	1.40	19.9	10.8	26.7	1.37	22.0	105.2	5.7
	4.50	1.6	3.8	15.6	12.2	0.78	1.36	20.2	11.5	27.4	1.38	22.7	106.1	5.8
100	2.25	0.3	0.8	12.7	10.9	0.85	1.64	18.3	7.8	24.6	1.34	20.0	102.4	5.4
	3.38	0.9	2.1	13.6	11.2	0.83	1.55	18.9	8.8	24.6	1.34	20.0	102.4	5.4
	4.50	1.6	3.7	14.0	11.5	0.82	1.50	19.2	9.3	24.6	1.34	20.0	102.4	5.4
110	2.25	0.3	0.7	11.3	10.2	0.91	1.80	17.4	6.3	24.6	1.34	20.0	102.4	5.4
	3.38	0.9	2.0	12.1	10.6	0.88	1.71	17.9	7.0	24.6	1.34	20.0	102.4	5.4
	4.50	1.5	3.6	12.5	10.7	0.86	1.67	18.1	7.5	24.6	1.34	20.0	102.4	5.4
120	2.25	0.3	0.7	10.0	9.8	0.98	1.98	16.8	5.0	24.6	1.34	20.0	102.4	5.4
	3.38	0.8	1.9	10.6	10.0	0.94	1.89	17.1	5.6	24.6	1.34	20.0	102.4	5.4
	4.50	1.5	3.4	11.0	10.1	0.92	1.84	17.3	6.0	24.6	1.34	20.0	102.4	5.4

Interpolation is permissible, extrapolation is not.  
 All entering air conditions are 80°F DB and 67°F WB in cooling and 70°F DB in heating.  
 All performance data is based upon the lower voltage of dual voltage rated units.  
 See performance correction tables for operating conditions other than those listed above.  
 Table does not reflect corrections for Fan and Pump watts used is ISO-13256.  
 Operation below 40°F EWT is based upon 20% methanol antifreeze solution.  
 All performance data is based upon High speed.  
 Operation below 60°F requires optional insulated water/refrigerant circuit.  
 Operation in the darker shaded region is only permissible with use of ClimateMaster Modulating Water valve. At these conditions, water flow will be reduced in order to maintain a leaving water temperature of 70°F  
 Operation in the lighter shaded areas may require antifreeze. See Performance Data Selection Notes for operation in the lighter shaded areas.

# Performance Data – TSL24 with PSC Motor

## 800 CFM Nominal (Rated) Airflow

Performance capacities shown in thousands of Btuh

EWT °F	GPM	WPD*		Cooling - EAT 80/67°F						Heating - EAT 70°F								
		PSI	FT	TC	SC	Sens/Tot Ratio	kW	HR	EER	HC	kW	HE	LAT	COP				
20	3.00	1.2	2.8	Operation not recommended										16.0	1.73	10.1	88.4	2.7
	4.50	2.5	5.9															
	6.00	4.1	9.6															
30	3.00	1.0	2.4	31.0	21.6	0.70	1.19	35.1	26.0	18.1	1.77	12.1	90.9	3.0				
	4.50	2.1	5.0	31.2	21.7	0.70	1.10	35.0	28.3	19.1	1.79	13.0	92.0	3.1				
	6.00	3.6	8.2	31.2	21.7	0.70	1.06	34.8	29.4	19.6	1.80	13.5	92.7	3.2				
40	3.00	0.8	1.7	30.4	21.3	0.70	1.31	34.9	23.1	21.4	1.83	15.2	94.7	3.4				
	4.50	1.6	3.6	30.9	21.6	0.70	1.22	35.1	25.4	22.6	1.85	16.3	96.1	3.6				
	6.00	2.5	5.9	31.1	21.7	0.70	1.17	35.1	26.5	23.3	1.86	17.0	96.9	3.7				
50	3.00	0.7	1.7	29.5	20.9	0.71	1.45	34.4	20.4	24.6	1.88	18.2	98.5	3.8				
	4.50	1.5	3.4	30.2	21.2	0.70	1.34	34.8	22.5	26.1	1.90	19.6	90.1	4.0				
	6.00	2.4	5.6	30.5	21.4	0.70	1.29	35.0	23.7	26.9	1.91	20.4	101.1	4.1				
60	3.00	0.7	1.6	28.3	20.3	0.72	1.60	33.8	17.7	27.9	1.93	21.3	102.2	4.2				
	4.50	1.4	3.3	29.2	20.8	0.71	1.48	34.3	19.8	29.5	1.96	22.9	104.1	4.4				
	6.00	2.3	5.4	29.7	21.0	0.71	1.42	34.5	20.8	30.5	1.97	23.7	105.2	4.5				
70	3.00	0.7	1.5	26.9	19.7	0.73	1.77	33.0	15.2	31.1	1.98	24.3	105.9	4.6				
	4.50	1.4	3.1	28.0	20.2	0.72	1.64	33.6	17.1	32.9	2.02	26.0	108.0	4.8				
	6.00	2.2	5.2	28.5	20.4	0.72	1.57	33.9	18.1	33.9	2.04	27.0	109.2	4.9				
80	3.00	0.6	1.4	25.4	18.9	0.75	1.97	32.1	12.9	34.2	2.04	27.2	109.5	4.9				
	4.50	1.3	3.0	26.5	19.5	0.73	1.82	32.7	14.6	36.2	2.09	29.1	111.8	5.1				
	6.00	2.1	5.0	27.1	19.8	0.73	1.75	33.1	15.5	37.3	2.12	30.1	113.1	5.2				
90	3.00	0.6	1.4	23.7	18.2	0.77	2.20	31.2	10.8	37.2	2.12	30.0	112.9	5.2				
	4.50	1.2	2.9	24.9	18.7	0.75	2.03	31.8	12.3	39.3	2.18	31.9	115.4	5.3				
	6.00	2.1	4.8	25.5	19.0	0.75	1.95	32.2	13.1	40.5	2.22	32.9	116.7	5.3				
100	3.00	0.6	1.3	22.0	17.3	0.79	2.46	30.4	8.9	37.3	2.12	30.1	113.1	5.2				
	4.50	1.2	2.8	23.2	17.9	0.77	2.27	30.9	10.2	37.3	2.12	30.1	113.1	5.2				
	6.00	2.0	4.6	23.8	18.2	0.76	2.18	31.3	10.9	37.3	2.12	30.1	113.1	5.2				
110	3.00	0.6	1.3	20.2	16.4	0.81	2.76	29.6	7.3	37.3	2.12	30.1	113.1	5.2				
	4.50	1.2	2.7	21.4	17.0	0.80	2.55	30.1	8.4	37.3	2.12	30.1	113.1	5.2				
	6.00	1.9	4.5	22.0	17.3	0.79	2.45	30.4	9.0	37.3	2.12	30.1	113.1	5.2				
120	3.00	0.5	1.2	18.4	15.5	0.84	3.12	29.1	5.9	37.3	2.12	30.1	113.1	5.2				
	4.50	1.1	2.6	19.6	16.1	0.82	2.88	29.4	6.8	37.3	2.12	30.1	113.1	5.2				
	6.00	1.9	4.4	20.2	16.4	0.81	2.76	29.6	7.3	37.3	2.12	30.1	113.1	5.2				

Interpolation is permissible, extrapolation is not.

All entering air conditions are 80°F DB and 67°F WB in cooling and 70°F DB in heating.

All performance data is based upon the lower voltage of dual voltage rated units.

See performance correction tables for operating conditions other than those listed above.

Table does not reflect corrections for Fan and Pump watts used is ISO-13256.

Operation below 40°F EWT is based upon 20% methanol antifreeze solution.

All performance data is based upon High speed.

Operation below 60°F requires optional insulated water/refrigerant circuit.

Operation in the darker shaded region is only permissible with use of ClimateMaster Modulating Water valve. At these conditions, water flow will be reduced in order to maintain a leaving water temperature of 70°F

Operation in the lighter shaded areas may require antifreeze. See Performance Data Selection Notes for operation in the lighter shaded areas.

# Performance Data – TSL30 with PSC Motor

## 1,000 CFM Nominal (Rated) Airflow

Performance capacities shown in thousands of Btuh

EWT °F	GPM	WPD*		Cooling - EAT 80/67°F						Heating - EAT 70°F				
		PSI	FT	TC	SC	Sens/Tot Ratio	kW	HR	EER	HC	kW	HE	LAT	COP
20	3.75	1.5	3.5	Operation not recommended										
	5.63	3.3	7.5											
	7.50	5.4	12.6											17.9
30	3.75	1.3	3.1	33.7	23.5	0.70	1.29	38.1	26.2	20.2	1.89	13.7	88.7	3.1
	5.63	2.9	6.6	33.3	22.8	0.69	1.21	37.5	27.6	21.1	1.90	14.7	89.5	3.3
	7.50	5.0	11.6	33.0	22.4	0.68	1.17	37.0	28.1	21.6	1.90	15.1	90.0	3.3
40	3.75	1.0	2.3	33.6	23.7	0.71	1.41	38.4	23.9	23.6	1.92	17.0	91.8	3.6
	5.63	2.1	4.9	33.7	23.6	0.70	1.32	38.2	25.5	24.7	1.93	18.1	92.8	3.7
	7.50	3.5	8.0	33.7	23.4	0.70	1.28	38.1	26.3	25.3	1.94	18.7	93.4	3.8
50	3.75	1.0	2.2	32.9	23.4	0.71	1.54	38.1	21.3	26.9	1.95	20.2	94.8	4.0
	5.63	2.0	4.7	33.4	23.7	0.71	1.45	38.4	23.1	28.2	1.97	21.4	96.0	4.2
	7.50	3.4	7.9	33.6	23.7	0.71	1.40	38.4	24.0	28.9	1.98	22.1	96.7	4.3
60	3.75	0.9	2.1	31.7	22.8	0.72	1.70	37.5	18.7	30.1	2.00	23.3	97.8	4.4
	5.63	2.0	4.5	32.5	23.3	0.72	1.59	38.0	20.5	31.6	2.02	24.7	99.2	4.6
	7.50	3.3	7.7	32.9	23.5	0.71	1.54	38.1	21.4	32.4	2.03	25.5	100.0	4.7
70	3.75	0.9	2.0	30.1	21.9	0.73	1.87	36.5	16.1	33.3	2.05	26.3	100.8	4.8
	5.63	1.9	4.4	31.2	22.5	0.72	1.75	37.2	17.8	35.0	2.08	27.9	102.3	4.9
	7.50	3.2	7.5	31.7	22.8	0.72	1.69	37.5	18.7	35.9	2.10	28.7	103.2	5.0
80	3.75	0.9	2.0	28.3	20.9	0.74	2.08	35.4	13.6	36.5	2.11	29.3	103.7	5.1
	5.63	1.8	4.2	29.5	21.6	0.73	1.94	36.1	15.2	38.4	2.15	31.0	105.4	5.2
	7.50	3.2	7.3	30.1	21.9	0.73	1.88	36.5	16.0	39.4	2.18	31.9	106.4	5.3
90	3.75	0.8	1.9	26.2	19.9	0.76	2.31	34.1	11.3	39.7	2.19	32.2	106.7	5.3
	5.63	1.8	4.1	27.5	20.5	0.75	2.16	34.9	12.7	41.7	2.24	34.1	108.5	5.5
	7.50	3.1	7.1	28.2	20.9	0.74	2.09	35.3	13.5	42.8	2.27	35.0	109.5	5.5
100	3.75	0.8	1.8	24.1	18.9	0.78	2.58	32.9	9.3	38.4	2.15	31.0	105.4	5.2
	5.63	1.7	3.9	25.4	19.5	0.77	2.41	33.6	10.5	38.4	2.15	31.0	105.4	5.2
	7.50	3.0	6.8	26.1	19.8	0.76	2.33	34.0	11.2	38.4	2.15	31.0	105.4	5.2
110	3.75	0.8	1.8	21.9	17.9	0.82	2.90	31.8	7.6	38.4	2.15	31.0	105.4	5.2
	5.63	1.7	3.8	23.2	18.5	0.80	2.71	32.4	8.6	38.4	2.15	31.0	105.4	5.2
	7.50	2.8	6.6	23.8	18.8	0.79	2.62	32.8	9.1	38.4	2.15	31.0	105.4	5.2
120	3.75	0.7	1.7	19.7	17.1	0.87	3.25	30.8	6.1	38.4	2.15	31.0	105.4	5.2
	5.63	1.6	3.7	20.9	17.6	0.84	3.05	31.3	6.9	38.4	2.15	31.0	105.4	5.2
	7.50	2.7	6.3	21.6	17.8	0.83	2.94	31.6	7.3	38.4	2.15	31.0	105.4	5.2

Interpolation is permissible, extrapolation is not.

All entering air conditions are 80°F DB and 67°F WB in cooling and 70°F DB in heating.

All performance data is based upon the lower voltage of dual voltage rated units.

See performance correction tables for operating conditions other than those listed above.

Table does not reflect corrections for Fan and Pump watts used is ISO-13256.

Operation below 40°F EWT is based upon 20% methanol antifreeze solution.

All performance data is based upon High speed.

Operation below 60°F requires optional insulated water/refrigerant circuit.

Operation in the darker shaded region is only permissible with use of ClimateMaster Modulating Water valve. At these conditions, water flow will be reduced in order to maintain a leaving water temperature of 70°F

Operation in the lighter shaded areas may require antifreeze. See Performance Data Selection Notes for operation in the lighter shaded areas.



# Performance Data – TSL36 with PSC Motor

## 1,200 CFM Nominal (Rated) Airflow

Performance capacities shown in thousands of Btuh

EWT °F	GPM	WPD*		Cooling - EAT 80/67°F						Heating - EAT 70°F				
		PSI	FT	TC	SC	Sens/Tot Ratio	kW	HR	EER	HC	kW	HE	LAT	COP
20	4.50	2.2	5.1	Operation not recommended						22.7	2.25	15.1	87.5	3.0
	6.75	4.5	10.3											
	9.00	7.2	16.7											
30	4.50	1.8	4.2	41.0	28.2	0.69	1.65	46.6	24.8	25.1	2.29	17.3	89.3	3.2
	6.75	3.6	8.4	40.1	27.4	0.68	1.55	45.4	25.8	26.1	2.30	18.3	90.1	3.3
	9.00	5.9	13.6	39.4	26.9	0.68	1.51	44.5	26.1	26.7	2.31	18.8	90.5	3.4
40	4.50	1.5	3.4	41.2	28.6	0.69	1.80	47.3	22.8	28.9	2.35	20.9	92.3	3.6
	6.75	2.9	6.8	41.2	28.4	0.69	1.69	46.9	24.3	30.3	2.37	22.2	93.3	3.7
	9.00	4.8	11.0	40.9	28.1	0.69	1.64	46.5	24.9	31.0	2.38	22.9	93.9	3.8
50	4.50	1.4	3.2	40.4	28.4	0.70	1.97	47.1	20.5	33.0	2.42	24.7	95.4	4.0
	6.75	2.8	6.4	41.0	28.6	0.70	1.85	47.3	22.2	34.6	2.44	26.2	96.6	4.1
	9.00	4.5	10.4	41.2	28.6	0.69	1.79	47.3	23.0	35.4	2.46	27.0	97.3	4.2
60	4.50	1.3	3.1	38.8	27.7	0.71	2.16	46.2	17.9	37.0	2.49	28.5	98.5	4.4
	6.75	2.6	6.1	40.0	28.2	0.71	2.03	46.9	19.7	38.8	2.52	30.2	99.9	4.5
	9.00	4.3	9.9	40.4	28.4	0.70	1.96	47.1	20.6	39.8	2.54	31.1	100.6	4.6
70	4.50	1.3	2.9	36.8	26.7	0.72	2.39	45.0	15.4	40.9	2.56	32.2	101.5	4.7
	6.75	2.5	5.8	38.3	27.4	0.72	2.23	45.9	17.2	42.8	2.59	34.0	103.0	4.8
	9.00	4.0	9.3	38.9	27.7	0.71	2.16	46.3	18.1	43.8	2.61	34.9	103.7	4.9
80	4.50	1.2	2.7	34.5	25.4	0.74	2.65	43.5	13.0	44.5	2.63	35.6	104.3	5.0
	6.75	2.3	5.4	36.1	26.3	0.73	2.47	44.5	14.6	46.3	2.66	37.2	105.7	5.1
	9.00	3.8	8.8	36.9	26.7	0.72	2.38	45.0	15.5	47.2	2.68	38.0	106.3	5.2
90	4.50	1.1	2.6	32.0	24.0	0.75	2.96	42.1	10.8	47.6	2.69	38.4	106.6	5.2
	6.75	2.2	5.1	33.6	24.9	0.74	2.75	43.0	12.2	49.1	2.73	39.8	107.8	5.3
	9.00	3.6	8.3	34.4	25.4	0.74	2.66	43.5	13.0	49.7	2.74	40.4	108.3	5.3
100	4.50	1.1	2.5	29.4	22.6	0.77	3.33	40.8	8.9	46.3	2.66	37.2	105.7	5.1
	6.75	2.1	4.9	31.0	23.5	0.76	3.09	41.6	10.0	46.3	2.66	37.2	105.7	5.1
	9.00	3.5	8.0	31.8	23.9	0.75	2.98	42.0	10.7	46.3	2.66	37.2	105.7	5.1
110	4.50	1.0	2.4	27.0	21.2	0.78	3.76	39.8	7.2	46.3	2.66	37.2	105.7	5.1
	6.75	2.0	4.7	28.5	22.0	0.77	3.49	40.4	8.2	46.3	2.66	37.2	105.7	5.1
	9.00	3.3	7.7	29.2	22.4	0.77	3.36	40.7	8.7	46.3	2.66	37.2	105.7	5.1
120	4.50	1.0	2.3	24.9	20.0	0.80	4.28	39.5	5.8	46.3	2.66	37.2	105.7	5.1
	6.75	2.0	4.5	26.1	20.7	0.79	3.96	39.6	6.6	46.3	2.66	37.2	105.7	5.1
	9.00	3.2	7.4	26.8	21.1	0.79	3.81	39.8	7.0	46.3	2.66	37.2	105.7	5.1

Interpolation is permissible, extrapolation is not.  
 All entering air conditions are 80°F DB and 67°F WB in cooling and 70°F DB in heating.  
 All performance data is based upon the lower voltage of dual voltage rated units.  
 See performance correction tables for operating conditions other than those listed above.  
 Table does not reflect corrections for Fan and Pump watts used is ISO-13256.  
 Operation below 40°F EWT is based upon 20% methanol antifreeze solution.  
 All performance data is based upon High speed.  
 Operation below 60°F requires optional insulated water/refrigerant circuit.  
 Operation in the darker shaded region is only permissible with use of ClimateMaster Modulating Water valve. At these conditions, water flow will be reduced in order to maintain a leaving water temperature of 70°F  
 Operation in the lighter shaded areas may require antifreeze. See Performance Data Selection Notes for operation in the lighter shaded areas.

# Performance Data – TSL09 with ECM Motor

## 400 CFM Nominal Airflow

Performance capacities shown in thousands of Btuh

EWT °F	GPM	WPD		Cooling - EAT 80/67°F						Heating - EAT 70°F				
		PSI	FT	TC	SC	Sens/Tot Ratio	kW	HR	EER	HC	kW	HE	LAT	COP
20	1.13	1.6	3.6	Operation not recommended						5.9	0.67	3.7	83.7	2.6
	1.69	3.0	6.9											
	2.25	4.9	11.3											
30	1.13	1.2	2.8	12.2	9.0	0.74	0.48	13.9	25.4	6.7	0.68	4.4	85.5	2.9
	1.69	2.7	6.2	12.2	8.7	0.72	0.45	13.7	26.8	7.0	0.68	4.7	86.3	3.0
	2.25	4.5	10.3	12.0	8.5	0.71	0.44	13.6	27.2	7.2	0.68	4.9	86.7	3.1
40	1.13	1.0	2.4	12.0	9.1	0.75	0.53	13.8	22.8	7.9	0.69	5.6	88.3	3.4
	1.69	1.9	4.5	12.2	9.0	0.74	0.49	13.9	24.9	8.4	0.69	6.0	89.3	3.5
	2.25	3.1	7.3	12.3	9.0	0.73	0.47	13.9	25.8	8.6	0.70	6.2	89.9	3.6
50	1.13	1.0	2.2	11.6	8.9	0.77	0.58	13.6	20.0	9.2	0.70	6.8	91.2	3.8
	1.69	1.9	4.3	12.0	9.0	0.75	0.54	13.8	22.3	9.7	0.71	7.3	92.5	4.0
	2.25	3.1	7.1	12.1	9.1	0.75	0.52	13.9	23.4	10.1	0.71	7.6	93.2	4.2
60	1.13	0.9	2.1	11.0	8.6	0.78	0.64	13.1	17.2	10.4	0.71	8.0	94.1	4.3
	1.69	1.8	4.2	11.5	8.8	0.77	0.59	13.5	19.4	11.1	0.72	8.7	95.7	4.5
	2.25	3.0	6.9	11.7	8.9	0.76	0.57	13.6	20.6	11.5	0.72	9.1	96.6	4.7
70	1.13	0.8	1.9	10.2	8.2	0.80	0.70	12.6	14.6	11.8	0.72	9.3	97.1	4.8
	1.69	1.8	4.1	10.8	8.5	0.78	0.65	13.0	16.6	12.6	0.73	10.1	99.0	5.1
	2.25	2.9	6.7	11.1	8.6	0.78	0.63	13.2	17.7	13.0	0.73	10.5	100.1	5.2
80	1.13	0.8	1.8	9.4	7.7	0.82	0.77	12.0	12.3	13.1	0.73	10.6	100.2	5.2
	1.69	1.7	3.9	10.0	8.0	0.80	0.72	12.5	14.0	14.0	0.74	11.5	102.3	5.6
	2.25	2.8	6.5	10.3	8.2	0.79	0.69	12.7	14.9	14.5	0.74	12.0	103.5	5.8
90	1.13	0.7	1.7	8.6	7.2	0.84	0.83	11.4	10.3	14.4	0.74	11.9	103.2	5.7
	1.69	1.6	3.8	9.2	7.5	0.82	0.79	11.9	11.7	15.4	0.74	12.9	105.6	6.1
	2.25	2.8	6.4	9.5	7.7	0.81	0.76	12.1	12.5	16.0	0.75	13.5	107.0	6.3
100	1.13	0.7	1.7	7.7	6.7	0.87	0.91	10.8	8.6	14.5	0.74	12.0	103.5	5.8
	1.69	1.6	3.7	8.3	7.0	0.85	0.86	11.2	9.7	14.5	0.74	12.0	103.5	5.8
	2.25	2.7	6.2	8.6	7.2	0.84	0.83	11.4	10.3	14.5	0.74	12.0	103.5	5.8
110	1.13	0.7	1.6	6.9	6.3	0.91	0.98	10.3	7.1	14.5	0.74	12.0	103.5	5.8
	1.69	1.6	3.6	7.4	6.6	0.88	0.93	10.6	8.0	14.5	0.74	12.0	103.5	5.8
	2.25	2.6	6.1	7.7	6.7	0.87	0.91	10.8	8.5	14.5	0.74	12.0	103.5	5.8
120	1.13	0.7	1.6	6.2	6.0	0.96	1.05	9.8	5.9	14.5	0.74	12.0	103.5	5.8
	1.69	1.5	3.5	6.6	6.2	0.93	1.01	10.1	6.6	14.5	0.74	12.0	103.5	5.8
	2.25	2.6	5.9	6.9	6.3	0.91	0.98	10.2	7.0	14.5	0.74	12.0	103.5	5.8

Interpolation is permissible, extrapolation is not.  
 All entering air conditions are 80°F DB and 67°F WB in cooling and 70°F DB in heating.  
 All performance data is based upon the lower voltage of dual voltage rated units.  
 See performance correction tables for operating conditions other than those listed above.  
 Table does not reflect corrections for Fan and Pump watts used is ISO-13256.  
 Operation below 40°F EWT is based upon 20% methanol antifreeze solution.  
 All performance data is based upon High speed.  
 Operation below 60°F requires optional insulated water/refrigerant circuit.  
 Operation in the darker shaded region is only permissible with use of ClimateMaster Modulating Water valve. At these conditions, water flow will be reduced in order to maintain a leaving water temperature of 70°F  
 Operation in the lighter shaded areas may require antifreeze. See Performance Data Selection Notes for operation in the lighter shaded areas.

# Performance Data – TSL12 with ECM Motor

## 450 CFM Nominal Airflow

Performance capacities shown in thousands of Btuh

EWT °F	GPM	WPD		Cooling - EAT 80/67°F						Heating - EAT 70°F				
		PSI	FT	TC	SC	Sens/Tot Ratio	kW	HR	EER	HC	kW	HE	LAT	COP
20	1.50	2.3	5.3	Operation not recommended						7.2	0.82	4.4	84.9	2.6
	2.25	4.7	10.8											
	3.00	7.8	18.0											
30	1.50	2.1	4.7	14.5	9.7	0.67	0.58	16.5	25.0	8.4	0.84	5.5	87.3	2.9
	2.25	4.3	9.9	14.3	9.3	0.65	0.55	16.1	25.7	8.8	0.85	6.0	88.2	3.1
	3.00	7.0	16.2	14.0	9.0	0.64	0.55	15.9	25.7	9.1	0.85	6.2	88.6	3.1
40	1.50	1.5	3.6	14.4	10.0	0.69	0.63	16.6	22.9	10.0	0.86	7.1	90.6	3.4
	2.25	3.1	7.3	14.5	9.8	0.67	0.59	16.5	24.6	10.6	0.87	7.6	91.7	3.6
	3.00	5.2	12.1	14.5	9.6	0.67	0.57	16.4	25.2	10.9	0.87	7.9	92.3	3.6
50	1.50	1.5	3.5	14.0	9.9	0.71	0.69	16.4	20.3	11.6	0.88	8.6	93.8	3.9
	2.25	3.1	7.1	14.4	10.0	0.69	0.64	16.6	22.3	12.2	0.89	9.2	95.1	4.0
	3.00	5.1	11.8	14.5	9.9	0.69	0.62	16.6	23.3	12.6	0.90	9.6	95.9	4.1
60	1.50	1.5	3.4	13.4	9.7	0.73	0.76	16.0	17.5	13.2	0.90	10.1	97.0	4.3
	2.25	3.0	6.9	13.9	9.9	0.71	0.71	16.3	19.6	13.9	0.91	10.8	98.6	4.5
	3.00	5.0	11.4	14.1	10.0	0.71	0.68	16.4	20.6	14.4	0.92	11.2	99.5	4.6
70	1.50	1.4	3.3	12.6	9.4	0.75	0.84	15.5	15.0	14.8	0.92	11.6	100.3	4.7
	2.25	2.9	6.7	13.2	9.7	0.73	0.78	15.9	16.8	15.7	0.94	12.5	102.1	4.9
	3.00	4.8	11.1	13.5	9.8	0.73	0.76	16.1	17.8	16.2	0.94	12.9	103.2	5.0
80	1.50	1.4	3.2	11.7	9.0	0.77	0.93	14.8	12.6	16.4	0.94	13.1	103.6	5.1
	2.25	2.8	6.5	12.3	9.3	0.75	0.87	15.3	14.2	17.4	0.96	14.2	105.8	5.3
	3.00	4.7	10.8	12.7	9.4	0.74	0.84	15.5	15.1	18.0	0.96	14.7	107.0	5.5
90	1.50	1.3	3.1	10.7	8.5	0.79	1.01	14.2	10.6	18.0	0.96	14.7	107.0	5.5
	2.25	2.8	6.4	11.4	8.8	0.77	0.95	14.6	11.9	19.3	0.98	15.9	109.6	5.8
	3.00	4.6	10.5	11.7	9.0	0.77	0.92	14.9	12.7	20.0	0.99	16.6	111.0	5.9
100	1.50	1.3	3.0	9.7	7.9	0.82	1.10	13.5	8.8	18.0	0.96	14.7	107.0	5.5
	2.25	2.7	6.2	10.3	8.3	0.80	1.05	13.9	9.9	18.0	0.96	14.7	107.0	5.5
	3.00	4.5	10.3	10.7	8.4	0.79	1.02	14.1	10.5	18.0	0.96	14.7	107.0	5.5
110	1.50	1.3	2.9	8.7	7.4	0.85	1.19	12.8	7.3	18.0	0.96	14.7	107.0	5.5
	2.25	2.6	6.1	9.3	7.7	0.83	1.14	13.2	8.2	18.0	0.96	14.7	107.0	5.5
	3.00	4.4	10.1	9.6	7.9	0.82	1.11	13.4	8.7	18.0	0.96	14.7	107.0	5.5
120	1.50	1.2	2.8	7.8	6.9	0.88	1.28	12.2	6.1	18.0	0.96	14.7	107.0	5.5
	2.25	2.6	5.9	8.3	7.2	0.86	1.23	12.5	6.8	18.0	0.96	14.7	107.0	5.5
	3.00	4.3	10.0	8.6	7.3	0.85	1.20	12.7	7.1	18.0	0.96	14.7	107.0	5.5

Interpolation is permissible, extrapolation is not.

All entering air conditions are 80°F DB and 67°F WB in cooling and 70°F DB in heating.

All performance data is based upon the lower voltage of dual voltage rated units.

See performance correction tables for operating conditions other than those listed above.

Table does not reflect corrections for Fan and Pump watts used is ISO-13256.

Operation below 40°F EWT is based upon 20% methanol antifreeze solution.

All performance data is based upon High speed.

Operation below 60°F requires optional insulated water/refrigerant circuit.

Operation in the darker shaded region is only permissible with use of ClimateMaster Modulating Water valve. At these conditions, water flow will be reduced in order to maintain a leaving water temperature of 70°F

Operation in the lighter shaded areas may require antifreeze. See Performance Data Selection Notes for operation in the lighter shaded areas.

# Performance Data – TSL15 with ECM Motor

## 600 CFM Nominal (Rated) Airflow

Performance capacities shown in thousands of Btuh

EWT °F	GPM	WPD		Cooling - EAT 80/67°F						Heating - EAT 70°F				
		PSI	FT	TC	SC	Sens/Tot Ratio	kW	HR	EER	HC	kW	HE	LAT	COP
20	1.88	0.5	1.2	Operation not recommended						8.9	0.92	5.7	83.6	2.8
	2.81	1.6	3.8											
	3.75	2.7	6.3											
30	1.88	0.4	1.0	18.9	13.8	0.73	0.57	20.8	32.8	10.2	0.94	7.0	85.7	3.2
	2.81	1.4	3.2	18.4	12.9	0.70	0.54	20.3	34.2	10.7	0.95	7.5	86.5	3.3
	3.75	2.3	5.4	18.1	12.2	0.67	0.53	19.9	34.2	11.0	0.95	7.8	86.9	3.4
40	1.88	0.3	0.7	18.8	14.4	0.76	0.64	21.0	29.2	12.2	0.97	8.9	88.8	3.7
	2.81	0.9	2.1	18.9	14.0	0.74	0.59	20.9	32.1	12.9	0.98	9.6	89.9	3.9
	3.75	1.5	3.5	18.8	13.7	0.73	0.57	20.8	33.2	13.3	0.98	10.0	90.5	4.0
50	1.88	0.3	0.6	18.2	14.2	0.78	0.73	20.7	25.0	14.3	0.99	10.9	92.0	4.2
	2.81	0.9	2.0	18.7	14.4	0.77	0.66	20.9	28.2	15.2	1.00	11.8	93.4	4.4
	3.75	1.4	3.3	18.8	14.3	0.76	0.63	21.0	29.8	15.7	1.01	12.3	94.2	4.6
60	1.88	0.3	0.6	17.2	13.7	0.80	0.82	20.0	21.0	16.4	1.01	13.0	95.3	4.7
	2.81	0.8	1.9	18.0	14.1	0.79	0.75	20.5	23.9	17.5	1.02	14.0	97.0	5.0
	3.75	1.4	3.2	18.3	14.3	0.78	0.72	20.7	25.5	18.1	1.03	14.6	97.9	5.2
70	1.88	0.3	0.6	16.1	13.0	0.81	0.93	19.2	17.3	18.6	1.03	15.1	98.6	5.3
	2.81	0.8	1.8	16.9	13.5	0.80	0.85	19.8	19.9	19.9	1.04	16.3	100.6	5.6
	3.75	1.3	3.0	17.3	13.8	0.79	0.81	20.1	21.3	20.6	1.05	17.0	101.7	5.7
80	1.88	0.2	0.6	14.8	12.1	0.82	1.04	18.3	14.2	20.7	1.05	17.1	101.9	5.8
	2.81	0.7	1.7	15.7	12.7	0.81	0.96	19.0	16.3	22.1	1.06	18.5	104.1	6.1
	3.75	1.3	2.9	16.1	13.0	0.81	0.92	19.3	17.5	22.9	1.06	19.3	105.3	6.3
90	4.50	1.1	2.6	13.5	11.3	0.84	1.16	17.4	11.6	22.8	1.06	19.2	105.1	6.3
	6.75	2.2	5.1	14.3	11.8	0.82	1.08	18.0	13.2	24.3	1.07	20.7	107.5	6.6
	9.00	3.6	8.3	14.8	12.1	0.82	1.04	18.3	14.2	25.1	1.08	21.5	108.7	6.8
100	4.50	1.1	2.5	12.2	10.5	0.87	1.28	16.6	9.5	22.9	1.06	19.3	105.3	6.3
	6.75	2.1	4.9	13.0	11.0	0.85	1.21	17.1	10.7	22.9	1.06	19.3	105.3	6.3
	9.00	3.5	8.0	13.4	11.2	0.84	1.17	17.4	11.4	22.9	1.06	19.3	105.3	6.3
110	4.50	1.0	2.4	11.1	10.0	0.91	1.41	15.9	7.8	22.9	1.06	19.3	105.3	6.3
	6.75	2.0	4.7	11.7	10.3	0.88	1.34	16.3	8.7	22.9	1.06	19.3	105.3	6.3
	9.00	3.3	7.7	12.1	10.5	0.87	1.30	16.5	9.3	22.9	1.06	19.3	105.3	6.3
120	4.50	1.0	2.3	10.2	9.9	0.97	1.54	15.4	6.6	22.9	1.06	19.3	105.3	6.3
	6.75	2.0	4.5	10.6	9.9	0.93	1.47	15.6	7.2	22.9	1.06	19.3	105.3	6.3
	9.00	3.2	7.4	10.9	10.0	0.92	1.43	15.8	7.6	22.9	1.06	19.3	105.3	6.3

Interpolation is permissible, extrapolation is not.

All entering air conditions are 80°F DB and 67°F WB in cooling and 70°F DB in heating.

All performance data is based upon the lower voltage of dual voltage rated units.

See performance correction tables for operating conditions other than those listed above.

Table does not reflect corrections for Fan and Pump watts used is ISO-13256.

Operation below 40°F EWT is based upon 20% methanol antifreeze solution.

All performance data is based upon High speed.

Operation below 60°F requires optional insulated water/refrigerant circuit.

Operation in the darker shaded region is only permissible with use of ClimateMaster Modulating Water valve. At these conditions, water flow will be reduced in order to maintain a leaving water temperature of 70°F

Operation in the lighter shaded areas may require antifreeze. See Performance Data Selection Notes for operation in the lighter shaded areas.

# Performance Data – TSL18 with ECM Motor

## 700 CFM Nominal (Rated) Airflow

Performance capacities shown in thousands of Btu/h

EWT °F	GPM	WPD		Cooling - EAT 80/67°F						Heating - EAT 70°F				
		PSI	FT	TC	SC	Sens/Tot Ratio	kW	HR	EER	HC	kW	HE	LAT	COP
20	2.25	0.8	1.8	Operation not recommended						9.1	1.06	5.5	82.0	2.5
	3.38	1.9	4.4											
	4.50	3.3	7.7											
30	2.25	0.6	1.4	20.4	14.1	0.69	0.72	22.9	28.4	11.1	1.10	7.4	84.7	3.0
	3.38	1.6	3.7	20.2	13.6	0.67	0.67	22.5	30.1	11.7	1.11	7.9	85.5	3.1
	4.50	2.8	6.6	20.0	13.2	0.66	0.65	22.2	30.7	12.1	1.11	8.3	85.9	3.2
40	2.25	0.5	1.1	20.2	14.3	0.71	0.80	22.9	25.3	13.6	1.14	9.7	87.9	3.5
	3.38	1.2	2.7	20.4	14.2	0.70	0.74	23.0	27.5	14.3	1.15	10.4	88.9	3.7
	4.50	2.0	4.7	20.4	14.1	0.69	0.72	22.9	28.6	14.7	1.15	10.8	89.5	3.8
50	2.25	0.4	1.0	19.5	14.1	0.72	0.89	22.5	21.8	15.9	1.17	11.9	91.0	4.0
	3.38	1.1	2.6	20.0	14.3	0.71	0.83	22.8	24.2	16.8	1.18	12.7	92.1	4.2
	4.50	2.0	4.5	20.2	14.3	0.71	0.80	22.9	25.4	17.2	1.18	13.2	92.7	4.3
60	2.25	0.4	1.0	18.5	13.7	0.74	1.00	21.9	18.5	18.1	1.19	14.0	93.8	4.4
	3.38	1.1	2.5	19.2	14.0	0.73	0.93	22.4	20.7	19.0	1.20	14.9	95.1	4.6
	4.50	1.9	4.3	19.5	14.1	0.72	0.89	22.6	21.9	19.5	1.21	15.4	95.8	4.7
70	2.25	0.4	0.9	17.2	13.0	0.76	1.12	21.0	15.4	20.1	1.21	16.0	96.6	4.9
	3.38	1.0	2.4	18.0	13.5	0.75	1.04	21.6	17.4	21.1	1.22	17.0	97.9	5.1
	4.50	1.8	4.1	18.4	13.7	0.74	1.00	21.9	18.4	21.7	1.23	17.5	98.6	5.2
80	2.25	0.4	0.9	15.8	12.3	0.78	1.25	20.0	12.7	22.1	1.24	17.9	99.2	5.2
	3.38	1.0	2.2	16.7	12.8	0.77	1.16	20.6	14.3	23.2	1.25	19.0	100.6	5.4
	4.50	1.7	4.0	17.1	13.0	0.76	1.12	21.0	15.2	23.8	1.26	19.5	101.4	5.6
90	2.25	0.4	0.8	14.3	11.6	0.81	1.39	19.0	10.3	24.0	1.26	19.7	101.7	5.6
	3.38	0.9	2.1	15.2	12.0	0.79	1.30	19.6	11.7	25.3	1.28	20.9	103.3	5.8
	4.50	1.6	3.8	15.6	12.3	0.78	1.26	19.9	12.4	25.9	1.29	21.5	104.2	5.9
100	2.25	0.3	0.8	12.8	10.9	0.85	1.54	18.0	8.3	23.2	1.25	19.0	100.6	5.4
	3.38	0.9	2.1	13.6	11.3	0.83	1.45	18.6	9.4	23.2	1.25	19.0	100.6	5.4
	4.50	1.6	3.7	14.1	11.5	0.82	1.41	18.9	10.0	23.2	1.25	19.0	100.6	5.4
110	2.25	0.3	0.7	11.3	10.2	0.90	1.70	17.1	6.7	23.2	1.25	19.0	100.6	5.4
	3.38	0.9	2.0	12.1	10.6	0.87	1.61	17.6	7.5	23.2	1.25	19.0	100.6	5.4
	4.50	1.5	3.6	12.5	10.7	0.86	1.57	17.8	8.0	23.2	1.25	19.0	100.6	5.4
120	2.25	0.3	0.7	10.0	9.8	0.97	1.88	16.4	5.3	23.2	1.25	19.0	100.6	5.4
	3.38	0.8	1.9	10.7	10.0	0.94	1.79	16.8	6.0	23.2	1.25	19.0	100.6	5.4
	4.50	1.5	3.4	11.0	10.1	0.92	1.74	17.0	6.3	23.2	1.25	19.0	100.6	5.4

Interpolation is permissible, extrapolation is not.

All entering air conditions are 80°F DB and 67°F WB in cooling and 70°F DB in heating.

All performance data is based upon the lower voltage of dual voltage rated units.

See performance correction tables for operating conditions other than those listed above.

Table does not reflect corrections for Fan and Pump watts used is ISO-13256.

Operation below 40°F EWT is based upon 20% methanol antifreeze solution.

All performance data is based upon High speed.

Operation below 60°F requires optional insulated water/refrigerant circuit.

Operation in the darker shaded region is only permissible with use of ClimateMaster Modulating Water valve. At these conditions, water flow will be reduced in order to maintain a leaving water temperature of 70°F

Operation in the lighter shaded areas may require antifreeze. See Performance Data Selection Notes for operation in the lighter shaded areas.

# Performance Data – TSL24 with ECM Motor

## 800 CFM Nominal (Rated) Airflow

Performance capacities shown in thousands of Btuh

EWT °F	GPM	WPD		Cooling - EAT 80/67°F						Heating - EAT 70°F				
		PSI	FT	TC	SC	Sens/Tot Ratio	kW	HR	EER	HC	kW	HE	LAT	COP
20	3.00	1.2	2.8	<b>Operation not recommended</b>										
	4.50	2.5	5.9											
	6.00	4.1	9.6											15.0
30	3.00	1.0	2.4	31.0	21.6	0.70	1.08	34.7	28.8	17.1	1.66	11.5	89.8	3.0
	4.50	2.1	5.0	31.2	21.7	0.70	0.99	34.6	31.6	18.0	1.68	12.3	90.8	3.2
	6.00	3.6	8.2	31.2	21.7	0.70	0.95	34.4	33.0	18.6	1.69	12.8	91.4	3.2
40	3.00	0.8	1.7	30.4	21.3	0.70	1.20	34.5	25.4	20.4	1.71	14.5	93.5	3.5
	4.50	1.6	3.6	30.9	21.6	0.70	1.10	34.7	28.1	21.5	1.73	15.6	94.8	3.6
	6.00	2.5	5.9	31.1	21.7	0.70	1.06	34.7	29.4	22.1	1.74	16.2	95.6	3.7
50	3.00	0.7	1.7	29.5	20.9	0.71	1.33	34.0	22.2	23.6	1.77	17.5	97.2	3.9
	4.50	1.5	3.4	30.3	21.2	0.70	1.22	34.4	24.7	24.9	1.79	18.8	98.8	4.1
	6.00	2.4	5.6	30.6	21.4	0.70	1.17	34.6	26.0	25.7	1.80	19.6	99.7	4.2
60	3.00	0.7	1.6	28.3	20.3	0.72	1.48	33.4	19.1	26.8	1.82	20.6	100.9	4.3
	4.50	1.4	3.3	29.3	20.8	0.71	1.36	33.9	21.5	28.3	1.84	22.1	102.7	4.5
	6.00	2.3	5.4	29.7	21.0	0.71	1.31	34.1	22.7	29.2	1.86	22.9	103.7	4.6
70	3.00	0.7	1.5	26.9	19.7	0.73	1.65	32.6	16.3	29.9	1.87	23.5	104.5	4.7
	4.50	1.4	3.1	28.0	20.2	0.72	1.52	33.2	18.4	31.7	1.91	25.2	106.6	4.9
	6.00	2.2	5.2	28.5	20.4	0.72	1.46	33.5	19.5	32.7	1.93	26.1	107.7	5.0
80	3.00	0.6	1.4	25.4	19.0	0.75	1.85	31.7	13.7	33.0	1.93	26.4	108.1	5.0
	4.50	1.3	3.0	26.6	19.5	0.73	1.70	32.4	15.6	34.9	1.98	28.2	110.3	5.2
	6.00	2.1	5.0	27.1	19.8	0.73	1.63	32.7	16.6	36.0	2.01	29.1	111.6	5.3
90	3.00	0.6	1.4	23.7	18.2	0.77	2.08	30.8	11.4	36.0	2.01	29.1	111.5	5.3
	4.50	1.2	2.9	24.9	18.7	0.75	1.91	31.5	13.0	38.1	2.07	31.0	113.9	5.4
	6.00	2.1	4.8	25.5	19.0	0.74	1.83	31.8	13.9	39.2	2.11	32.0	115.2	5.4
100	3.00	0.6	1.3	22.0	17.3	0.79	2.34	30.0	9.4	36.0	2.01	29.1	111.6	5.3
	4.50	1.2	2.8	23.2	17.9	0.77	2.15	30.6	10.8	36.0	2.01	29.1	111.6	5.3
	6.00	2.0	4.6	23.8	18.2	0.76	2.07	30.9	11.5	36.0	2.01	29.1	111.6	5.3
110	3.00	0.6	1.3	20.2	16.5	0.81	2.64	29.3	7.7	36.0	2.01	29.1	111.6	5.3
	4.50	1.2	2.7	21.4	17.1	0.80	2.43	29.7	8.8	36.0	2.01	29.1	111.6	5.3
	6.00	1.9	4.5	22.0	17.4	0.79	2.33	30.0	9.4	36.0	2.01	29.1	111.6	5.3
120	3.00	0.5	1.2	18.5	15.6	0.84	2.99	28.7	6.2	36.0	2.01	29.1	111.6	5.3
	4.50	1.1	2.6	19.6	16.2	0.82	2.76	29.0	7.1	36.0	2.01	29.1	111.6	5.3
	6.00	1.9	4.4	20.2	16.5	0.81	2.65	29.3	7.6	36.0	2.01	29.1	111.6	5.3

Interpolation is permissible, extrapolation is not.

All entering air conditions are 80°F DB and 67°F WB in cooling and 70°F DB in heating.

All performance data is based upon the lower voltage of dual voltage rated units.

See performance correction tables for operating conditions other than those listed above.

Table does not reflect corrections for Fan and Pump watts used is ISO-13256.

Operation below 40°F EWT is based upon 20% methanol antifreeze solution.

All performance data is based upon High speed.

Operation below 60°F requires optional insulated water/refrigerant circuit.

Operation in the darker shaded region is only permissible with use of ClimateMaster Modulating Water valve. At these conditions, water flow will be reduced in order to maintain a leaving water temperature of 70°F

Operation in the lighter shaded areas may require antifreeze. See Performance Data Selection Notes for operation in the lighter shaded areas.



# Performance Data – TSL30 with ECM Motor

## 1,000 CFM Nominal (Rated) Airflow

Performance capacities shown in thousands of Btuh

EWT °F	GPM	WPD		Cooling - EAT 80/67°F						Heating - EAT 70°F				
		PSI	FT	TC	SC	Sens/Tot Ratio	kW	HR	EER	HC	kW	HE	LAT	COP
20	3.75	1.5	3.5	Operation not recommended						17.2	1.80	11.1	85.9	2.8
	5.63	3.3	7.5											
	7.50	5.4	12.6											
30	3.75	1.3	3.1	33.7	23.4	0.70	1.20	37.8	28.0	19.5	1.82	13.3	88.0	3.1
	5.63	2.9	6.6	33.3	22.8	0.69	1.13	37.2	29.5	20.3	1.82	14.1	88.8	3.3
	7.50	5.0	11.6	33.0	22.4	0.68	1.09	36.7	30.2	20.8	1.83	14.6	89.2	3.3
40	3.75	1.0	2.3	33.6	23.7	0.71	1.32	38.1	25.4	22.7	1.84	16.4	91.0	3.6
	5.63	2.1	4.9	33.7	23.6	0.70	1.24	38.0	27.2	23.8	1.85	17.5	92.0	3.8
	7.50	3.5	8.0	33.7	23.4	0.70	1.20	37.8	28.1	24.4	1.86	18.0	92.5	3.8
50	3.75	1.0	2.2	32.9	23.4	0.71	1.46	37.9	22.5	25.9	1.88	19.5	94.0	4.0
	5.63	2.0	4.7	33.4	23.7	0.71	1.36	38.1	24.5	27.2	1.89	20.7	95.1	4.2
	7.50	3.4	7.9	33.6	23.7	0.71	1.32	38.1	25.5	27.8	1.90	21.3	95.7	4.3
60	3.75	0.9	2.1	31.7	22.8	0.72	1.61	37.2	19.6	29.1	1.92	22.5	96.9	4.4
	5.63	2.0	4.5	32.5	23.3	0.72	1.51	37.7	21.6	30.5	1.94	23.9	98.2	4.6
	7.50	3.3	7.7	32.9	23.5	0.71	1.46	37.9	22.6	31.3	1.96	24.6	98.9	4.7
70	3.75	0.9	2.0	30.1	21.9	0.73	1.79	36.2	16.8	32.2	1.98	25.5	99.8	4.8
	5.63	1.9	4.4	31.2	22.5	0.72	1.67	36.9	18.7	33.8	2.01	27.0	101.2	4.9
	7.50	3.2	7.5	31.7	22.8	0.72	1.61	37.2	19.7	34.7	2.02	27.8	102.0	5.0
80	3.75	0.9	2.0	28.3	20.9	0.74	2.00	35.1	14.2	35.4	2.04	28.4	102.7	5.1
	5.63	1.8	4.2	29.5	21.6	0.73	1.86	35.9	15.9	37.1	2.08	30.0	104.3	5.2
	7.50	3.2	7.3	30.1	21.9	0.73	1.79	36.2	16.8	38.1	2.10	30.9	105.2	5.3
90	3.75	0.8	1.9	26.3	19.9	0.76	2.23	33.9	11.8	38.5	2.11	31.3	105.5	5.3
	5.63	1.8	4.1	27.6	20.5	0.75	2.08	34.6	13.3	40.4	2.17	33.0	107.3	5.5
	7.50	3.1	7.1	28.2	20.9	0.74	2.01	35.0	14.1	41.4	2.20	33.9	108.3	5.5
100	3.75	0.8	1.8	24.1	18.9	0.78	2.50	32.6	9.6	37.1	2.08	30.0	104.3	5.2
	5.63	1.7	3.9	25.4	19.5	0.77	2.33	33.4	10.9	37.1	2.08	30.0	104.3	5.2
	7.50	3.0	6.8	26.1	19.8	0.76	2.25	33.8	11.6	37.1	2.08	30.0	104.3	5.2
110	3.75	0.8	1.8	21.9	17.9	0.82	2.81	31.5	7.8	37.1	2.08	30.0	104.3	5.2
	5.63	1.7	3.8	23.2	18.5	0.80	2.62	32.2	8.8	37.1	2.08	30.0	104.3	5.2
	7.50	2.8	6.6	23.9	18.8	0.79	2.53	32.5	9.4	37.1	2.08	30.0	104.3	5.2
120	3.75	0.7	1.7	19.8	17.1	0.87	3.17	30.6	6.2	37.1	2.08	30.0	104.3	5.2
	5.63	1.6	3.7	21.0	17.6	0.84	2.96	31.1	7.1	37.1	2.08	30.0	104.3	5.2
	7.50	2.7	6.3	21.6	17.8	0.83	2.86	31.4	7.5	37.1	2.08	30.0	104.3	5.2

Interpolation is permissible, extrapolation is not.

All entering air conditions are 80°F DB and 67°F WB in cooling and 70°F DB in heating.

All performance data is based upon the lower voltage of dual voltage rated units.

See performance correction tables for operating conditions other than those listed above.

Table does not reflect corrections for Fan and Pump watts used is ISO-13256.

Operation below 40°F EWT is based upon 20% methanol antifreeze solution.

All performance data is based upon High speed.

Operation below 60°F requires optional insulated water/refrigerant circuit.

Operation in the darker shaded region is only permissible with use of ClimateMaster Modulating Water valve. At these conditions, water flow will be reduced in order to maintain a leaving water temperature of 70°F

Operation in the lighter shaded areas may require antifreeze. See Performance Data Selection Notes for operation in the lighter shaded areas.

# Performance Data – TSL36 with ECM Motor

## 1,200 CFM Nominal (Rated) Airflow

Performance capacities shown in thousands of Btuh

EWT °F	GPM	WPD		Cooling - EAT 80/67°F						Heating - EAT 70°F				
		PSI	FT	TC	SC	Sens/Tot Ratio	kW	HR	EER	HC	kW	HE	LAT	COP
20	4.50	2.2	5.1	Operation not recommended										
	6.75	4.5	10.3											
	9.00	7.2	16.7											
30	4.50	1.8	4.2	41.0	28.2	0.69	1.58	46.4	25.9	24.4	2.22	16.9	88.8	3.2
	6.75	3.6	8.4	40.1	27.4	0.68	1.48	45.1	27.0	25.4	2.24	17.8	89.6	3.3
	9.00	5.9	13.6	39.4	26.8	0.68	1.44	44.3	27.4	25.9	2.25	18.3	90.0	3.4
40	4.50	1.5	3.4	41.2	28.6	0.69	1.73	47.1	23.8	28.2	2.28	20.4	91.7	3.6
	6.75	2.9	6.8	41.2	28.4	0.69	1.62	46.7	25.3	29.5	2.30	21.6	92.7	3.7
	9.00	4.8	11.0	40.9	28.1	0.69	1.57	46.3	26.0	30.2	2.32	22.3	93.2	3.8
50	4.50	1.4	3.2	40.4	28.4	0.70	1.90	46.9	21.2	32.2	2.35	24.1	94.8	4.0
	6.75	2.8	6.4	41.0	28.6	0.70	1.78	47.1	23.1	33.7	2.38	25.6	95.9	4.2
	9.00	4.5	10.4	41.2	28.6	0.69	1.72	47.1	23.9	34.5	2.39	26.4	96.6	4.2
60	4.50	1.3	3.1	38.9	27.7	0.71	2.09	46.0	18.6	36.1	2.42	27.9	97.8	4.4
	6.75	2.6	6.1	40.0	28.2	0.71	1.96	46.7	20.5	37.9	2.45	29.5	99.1	4.5
	9.00	4.3	9.9	40.4	28.4	0.70	1.89	46.9	21.4	38.8	2.47	30.4	99.9	4.6
70	4.50	1.3	2.9	36.9	26.7	0.72	2.32	44.8	15.9	40.0	2.49	31.5	100.8	4.7
	6.75	2.5	5.8	38.3	27.4	0.72	2.16	45.7	17.7	41.8	2.53	33.2	102.2	4.8
	9.00	4.0	9.3	38.9	27.7	0.71	2.09	46.1	18.7	42.7	2.55	34.0	102.9	4.9
80	4.50	1.2	2.7	34.5	25.4	0.74	2.58	43.3	13.4	43.5	2.56	34.8	103.5	5.0
	6.75	2.3	5.4	36.1	26.3	0.73	2.40	44.3	15.0	45.2	2.60	36.4	104.8	5.1
	9.00	3.8	8.8	36.9	26.7	0.72	2.31	44.8	15.9	46.1	2.62	37.1	105.5	5.2
90	4.50	1.1	2.6	32.0	24.0	0.75	2.89	41.9	11.1	46.5	2.63	37.6	105.8	5.2
	6.75	2.2	5.1	33.6	24.9	0.74	2.68	42.8	12.5	47.9	2.66	38.9	106.9	5.3
	9.00	3.6	8.3	34.5	25.4	0.74	2.59	43.3	13.3	48.5	2.67	39.4	107.4	5.3
100	4.50	1.1	2.5	29.5	22.6	0.77	3.25	40.6	9.1	45.2	2.60	36.4	104.8	5.1
	6.75	2.1	4.9	31.0	23.5	0.76	3.02	41.3	10.3	45.2	2.60	36.4	104.8	5.1
	9.00	3.5	8.0	31.9	23.9	0.75	2.91	41.8	11.0	45.2	2.60	36.4	102.8	5.1
110	4.50	1.0	2.4	27.0	21.2	0.78	3.69	39.6	7.3	45.2	2.60	36.4	104.8	5.1
	6.75	2.0	4.7	28.5	22.0	0.77	3.42	40.1	8.3	45.2	2.60	36.4	104.8	5.1
	9.00	3.3	7.7	29.2	22.5	0.77	3.29	40.5	8.9	45.2	2.60	36.4	104.8	5.1
120	4.50	1.0	2.3	24.9	20.0	0.80	4.20	39.3	5.9	45.2	2.60	36.4	104.8	5.1
	6.75	2.0	4.5	26.1	20.7	0.79	3.89	39.4	6.7	45.2	2.60	36.4	104.8	5.1
	9.00	3.2	7.4	26.8	21.1	0.79	3.74	39.5	7.2	45.2	2.60	36.4	104.8	5.1

Interpolation is permissible, extrapolation is not.

All entering air conditions are 80°F DB and 67°F WB in cooling and 70°F DB in heating.

All performance data is based upon the lower voltage of dual voltage rated units.

See performance correction tables for operating conditions other than those listed above.

Table does not reflect corrections for Fan and Pump watts used is ISO-13256.

Operation below 40°F EWT is based upon 20% methanol antifreeze solution.

All performance data is based upon High speed.

Operation below 60°F requires optional insulated water/refrigerant circuit.

Operation in the darker shaded region is only permissible with use of ClimateMaster Modulating Water valve. At these conditions, water flow will be reduced in order to maintain a leaving water temperature of 70°F

Operation in the lighter shaded areas may require antifreeze. See Performance Data Selection Notes for operation in the lighter shaded areas.

# Performance Data – TSL09 Hybrid

## 400 CFM Nominal Airflow

Performance capacities shown in thousands of Btuh

Hydronic Heating Entering Air 70°F DB						
EWT (°F)	GPM	WPD (PSI)	WPD (FT)	Capacity (BTUH)	kW	LAT (°F)
90	1.13	0.6	1.4	5000	0.04	81.5
	1.69	2.4	5.4	5400	0.04	82.6
	2.25	4.1	9.5	5900	0.05	83.6
95	1.13	0.6	1.4	6200	0.04	84.4
	1.69	2.3	5.4	6700	0.04	85.7
	2.25	4.1	9.5	7300	0.05	86.9
100	1.13	0.6	1.3	7400	0.04	87.3
	1.69	2.3	5.4	8100	0.04	88.8
	2.25	4.1	9.4	8800	0.05	90.3
105	1.13	0.6	1.3	8700	0.04	90.1
	1.69	2.3	5.3	9400	0.04	91.9
	2.25	4.1	9.4	10200	0.05	93.6
110	1.13	0.6	1.3	9900	0.04	93.0
	1.69	2.3	5.3	10800	0.05	95.0
	2.25	4.0	9.3	11700	0.05	96.9
115	1.13	0.6	1.3	11100	0.04	95.8
	1.69	2.3	5.3	12100	0.05	98.0
	2.25	4.0	9.3	13100	0.05	100.3
120	1.13	0.6	1.3	12300	0.04	98.7
	1.69	2.3	5.3	13400	0.05	101.1
	2.25	4.0	9.3	14600	0.05	103.6

# Performance Data – TSL12 Hybrid

## 450 CFM Nominal Airflow

Performance capacities shown in thousands of Btuh

Hydronic Heating Entering Air 70°F DB						
EWT (°F)	GPM	WPD (PSI)	WPD (FT)	Capacity (BTUH)	kW	LAT (°F)
90	1.50	1.8	4.1	5600	0.06	81.7
	2.25	4.1	9.5	6300	0.07	83.1
	3.00	7.5	17.4	6600	0.09	83.7
95	1.50	1.8	4.0	7000	0.06	84.5
	2.25	4.1	9.5	7900	0.07	86.3
	3.00	7.5	17.3	8200	0.09	87.0
100	1.50	1.7	4.0	8400	0.06	87.4
	2.25	4.1	9.4	9400	0.07	89.5
	3.00	7.5	17.2	9800	0.09	90.3
105	1.50	1.7	4.0	9800	0.06	90.2
	2.25	4.1	9.4	11000	0.07	92.6
	3.00	7.4	17.1	11500	0.09	93.6
110	1.50	1.7	4.0	11200	0.06	93.1
	2.25	4.1	9.4	12600	0.07	95.9
	3.00	7.4	17.1	13100	0.09	96.9
115	1.50	1.7	4.0	12600	0.06	96.0
	2.25	4.0	9.3	14100	0.07	99.1
	3.00	7.4	17.0	14700	0.09	100.3
120	1.50	1.7	4.0	14000	0.06	98.8
	2.25	4.0	9.3	15700	0.07	102.3
	3.00	7.3	17.0	16300	0.09	103.6

# Performance Data – TSL15 Hybrid

## 600 CFM Nominal Airflow

Performance capacities shown in thousands of Btuh

Hydronic Heating Entering Air 70°F DB						
EWT (°F)	GPM	WPD (PSI)	WPD (FT)	Capacity (BTUH)	kW	LAT (°F)
90	1.88	0.3	0.6	7900	0.06	82.2
	2.81	2.1	4.9	8300	0.07	82.8
	3.75	4.0	9.1	8600	0.08	83.3
95	1.88	0.3	0.6	9800	0.06	85.1
	2.81	2.1	4.9	10300	0.07	85.9
	3.75	4.0	9.1	10700	0.08	86.6
100	1.88	0.3	0.6	11700	0.06	88.1
	2.81	2.1	4.8	12300	0.07	89.0
	3.75	3.9	9.1	12900	0.08	89.8
105	1.88	0.2	0.6	13600	0.06	91.0
	2.81	2.1	4.8	14300	0.07	92.1
	3.75	3.9	9.1	15000	0.08	93.1
110	1.88	0.2	0.5	15600	0.06	94.1
	2.81	2.1	4.8	16400	0.07	95.2
	3.75	3.9	9.1	17100	0.09	96.4
115	1.88	0.2	0.5	17600	0.06	97.1
	2.81	2.1	4.7	18400	0.07	98.4
	3.75	3.9	9.0	19300	0.09	99.6
120	1.88	0.2	0.5	19600	0.06	100.1
	2.81	2.0	4.7	20500	0.08	101.5
	3.75	3.9	9.0	21400	0.09	102.9

# Performance Data – TSL18 Hybrid

## 700 CFM Nominal Airflow

Performance capacities shown in thousands of Btuh

Hydronic Heating Entering Air 70°F DB						
EWT (°F)	GPM	WPD (PSI)	WPD (FT)	Capacity (BTUH)	kW	LAT (°F)
90	2.25	1.0	2.3	8900	0.11	81.8
	3.38	3.2	7.5	9600	0.13	82.6
	4.50	6.2	14.3	9900	0.16	83.2
95	2.25	1.0	2.3	11100	0.12	84.7
	3.38	3.2	7.4	11900	0.13	85.7
	4.50	6.2	14.3	12400	0.16	86.4
100	2.25	1.0	2.3	13300	0.12	87.5
	3.38	3.2	7.4	14200	0.14	88.8
	4.50	6.1	14.2	14800	0.16	89.6
105	2.25	1.0	2.2	15500	0.12	90.4
	3.38	3.2	7.4	16600	0.14	91.9
	4.50	6.1	14.2	17300	0.17	92.8
110	2.25	1.0	2.2	17700	0.13	93.3
	3.38	3.2	7.4	19000	0.14	95.0
	4.50	6.1	14.1	19700	0.17	96.1
115	2.25	0.9	2.2	19900	0.13	96.3
	3.38	3.2	7.3	21300	0.15	98.1
	4.50	6.1	14.0	22200	0.17	99.3
120	2.25	0.9	2.2	22100	0.13	99.2
	3.38	3.2	7.3	23700	0.15	101.3
	4.50	6.0	13.9	24700	0.18	102.5



# Performance Data – TSL24 Hybrid

## 800 CFM Nominal Airflow

Performance capacities shown in thousands of Btuh

Hydronic Heating Entering Air 70°F DB						
EWT (°F)	GPM	WPD (PSI)	WPD (FT)	Capacity (BTUH)	kW	LAT (°F)
90	3.00	1.2	2.8	11100	0.10	83.0
	4.50	3.0	6.9	12200	0.12	84.3
	6.00	5.4	12.4	13000	0.14	85.2
95	3.00	1.2	2.8	13800	0.10	86.2
	4.50	3.0	6.9	15200	0.12	87.8
	6.00	5.3	12.3	16200	0.15	88.9
100	3.00	1.2	2.8	16500	0.10	89.4
	4.50	3.0	6.9	18200	0.12	91.3
	6.00	5.3	12.3	19400	0.15	92.7
105	3.00	1.2	2.7	19200	0.11	92.6
	4.50	3.0	6.9	21200	0.12	94.8
	6.00	5.3	12.2	22600	0.15	96.4
110	3.00	1.2	2.7	22000	0.11	95.8
	4.50	3.0	6.8	24200	0.12	98.3
	6.00	5.3	12.2	25900	0.15	100.1
115	3.00	1.2	2.7	24700	0.11	99.0
	4.50	3.0	6.8	27200	0.13	101.8
	6.00	5.3	12.2	29000	0.15	103.8
120	3.00	1.2	2.7	27500	0.11	102.2
	4.50	3.0	6.8	30300	0.13	105.3
	6.00	5.3	12.1	32200	0.16	107.5

# Performance Data – TSL30 Hybrid

## 1,000 CFM Nominal Airflow

Performance capacities shown in thousands of Btuh

Hydronic Heating Entering Air 70°F DB						
EWT (°F)	GPM	WPD (PSI)	WPD (FT)	Capacity (BTUH)	kW	LAT (°F)
90	3.75	2.1	4.8	13500	0.17	82.5
	5.63	4.5	10.4	15300	0.19	84.2
	7.50	8.9	20.5	15700	0.26	85.5
95	3.75	2.1	4.8	16800	0.17	85.5
	5.63	4.5	10.3	19100	0.20	87.7
	7.50	8.8	20.4	19600	0.27	88.1
100	3.75	2.1	4.8	20100	0.18	88.6
	5.63	4.5	10.3	23000	0.20	91.2
	7.50	8.8	20.3	23500	0.27	91.7
105	3.75	2.1	4.8	23400	0.18	91.7
	5.63	4.4	10.3	26800	0.21	94.7
	7.50	8.7	20.2	27400	0.28	95.3
110	3.75	2.1	4.8	26700	0.19	94.7
	5.63	4.4	10.2	30600	0.21	98.2
	7.50	8.7	20.1	31300	0.28	98.8
115	3.75	2.1	4.8	30000	0.19	97.8
	5.63	4.4	10.2	34300	0.22	101.7
	7.50	8.7	20.0	35100	0.28	102.4
120	3.75	2.1	4.8	33400	0.19	100.9
	5.63	4.4	10.2	38100	0.22	105.2
	7.50	8.6	19.9	39000	0.29	105.9

# Performance Data – TSL36 Hybrid

## 1,200 CFM Nominal Airflow

Performance capacities shown in thousands of Btuh

Hydronic Heating Entering Air 70°F DB						
EWT (°F)	GPM	WPD (PSI)	WPD (FT)	Capacity (BTUH)	kW	LAT (°F)
90	4.50	3.0	6.9	16600	0.26	82.9
	6.75	7.1	16.4	18400	0.31	84.2
	9.00	12.4	28.6	19200	0.40	84.7
95	4.50	3.0	6.9	20700	0.26	85.9
	6.75	7.1	16.3	23000	0.32	87.7
	9.00	12.3	28.4	23900	0.40	88.3
100	4.50	3.0	6.9	24800	0.27	89.0
	6.75	7.0	16.3	27500	0.33	91.1
	9.00	12.2	28.3	28500	0.41	91.9
105	4.50	3.0	6.8	28800	0.27	92.1
	6.75	7.0	16.2	32000	0.33	94.6
	9.00	12.2	28.1	33200	0.42	95.5
110	4.50	2.9	6.8	32800	0.28	95.2
	6.75	7.0	16.1	36500	0.34	98.0
	9.00	12.1	28.0	37800	0.42	99.0
115	4.50	2.9	6.8	36800	0.28	98.3
	6.75	6.9	16.0	40900	0.34	101.4
	9.00	12.0	27.8	42400	0.43	102.5
120	4.50	2.9	6.7	40900	0.29	101.3
	6.75	6.9	15.9	45400	0.35	104.8
	9.00	11.9	27.6	47100	0.43	106.0

# Performance Data – Correction Tables

## Airflow Correction Table

Airflow % of Nominal (Rated) SCFM	Cooling				Heating		
	Total Capacity	Sensible Capacity	Power	Heat of Rejection	Heating Capacity	Power	Heat of Extraction
70	0.921	0.8	0.969	0.943	0.942	1.077	0.934
75	0.934	0.833	0.974	0.952	0.952	1.062	0.947
80	0.946	0.866	0.979	0.961	0.961	1.048	0.958
85	0.958	0.899	0.985	0.97	0.971	1.035	0.969
90	0.971	0.932	0.99	0.979	0.980	1.023	0.979
95	0.985	0.966	0.995	0.989	0.990	1.011	0.989
100	1.000	1.000	1.000	1.000	1.000	1.000	1.000
105	1.017	1.035	1.005	1.013	1.010	0.989	1.011

## Entering Air Correction Table

Heating			
Entering Air DB°F	Heating Capacity	Power	Heat of Extraction
45	1.107	0.768	1.181
50	1.085	0.814	1.143
55	1.064	0.860	1.108
60	1.043	0.906	1.072
65	1.022	0.952	1.036
68	1.009	0.981	1.015
70	1.000	1.000	1.000
75	0.982	1.050	0.962
80	0.953	1.103	0.921

Ent. Air WB °F	Total Capacity	Cooling								Power	Heat of Rejection
		Sensible Capacity-Entering Air Dry Bulb, °F									
		65	70	75	80	80.6	85	90	95		
45	0.557	*	*	*	*	*	*	*	*	0.986	0.672
50	0.658	1.100	*	*	*	*	*	*	*	0.989	0.747
55	0.758	0.861	1.091	*	*	*	*	*	*	0.992	0.821
60	0.859	0.623	0.854	1.091	1.325	1.383	*	*	*	0.996	0.896
65	0.960		0.617	0.857	1.093	1.151	1.326	*	*	0.999	0.970
66.2	0.984		0.561	0.801	1.037	1.095	1.270	1.521	*	1.000	0.988
67	1.000		0.523	0.763	1.000	1.058	1.232	1.482	*	1.000	1.000
70	1.060			0.623	0.861	0.919	1.090	1.339	1.563	1.002	1.045
75	1.161				0.629	0.686	0.854	1.101	1.318	1.005	1.119

\* = Sensible capacity equals total capacity  
 AHRI/ISO/ASHRAE 13256-1 uses entering air conditions of Cooling - 80.6°F DB/66.2°F WB, and Heating - 68°F DB/59°F WB  
 entering air temperature

## Motorized Water Valve

Unit Size	N.O./N.C. Motorized Water Valves (MWV)		Modulating Valve	
	Cv	Max Close-Off Pressure	Cv	Max Close-Off Pressure
	gpm/psig	psig	gpm/psig	psig
09	4.9	125	3.0	200
12	4.9	125	3.0	200
15	10.3	125	4.7	200
18	10.3	125	4.7	200
24	10.3	125	7.4	200
30	10.3	125	7.4	200
36	10.3	125	7.4	200

# Antifreeze Correction Table

EWT	Antifreeze Type	Antifreeze %	Cooling			Heating		WPD
			Total Cap	Sensible Cap	Watts	Total Cap	Watts	
90	Water	0%	1	1	1	1	1	1
	Ethanol	5%	0.998	0.998	1.002	0.996	0.999	1.025
		10%	0.996	0.996	1.003	0.991	0.997	1.048
		15%	0.994	0.994	1.005	0.987	0.996	1.098
		20%	0.991	0.991	1.006	0.982	0.994	1.142
		25%	0.986	0.986	1.009	0.972	0.991	1.207
		30%	0.981	0.981	1.012	0.962	0.988	1.265
		35%	0.977	0.977	1.015	0.953	0.985	1.312
		40%	0.972	0.972	1.018	0.943	0.982	1.37
		45%	0.966	0.966	1.023	0.931	0.978	1.431
	50%	0.959	0.959	1.027	0.918	0.974	1.494	
	Ethylene Glycol	5%	0.998	0.998	1.002	0.996	0.999	1.021
		10%	0.996	0.996	1.003	0.991	0.997	1.04
		15%	0.994	0.994	1.004	0.987	0.996	1.079
		20%	0.991	0.991	1.005	0.982	0.995	1.114
		25%	0.988	0.988	1.008	0.976	0.993	1.146
		30%	0.985	0.985	1.01	0.969	0.99	1.175
		35%	0.982	0.982	1.012	0.963	0.988	1.208
		40%	0.979	0.979	1.014	0.956	0.986	1.243
		45%	0.976	0.976	1.016	0.95	0.984	1.278
	50%	0.972	0.972	1.018	0.943	0.982	1.314	
	Methanol	5%	0.997	0.997	1.002	0.993	0.998	1.039
		10%	0.993	0.993	1.004	0.986	0.996	1.075
		15%	0.99	0.99	1.007	0.979	0.994	1.116
		20%	0.986	0.986	1.009	0.972	0.991	1.154
		25%	0.982	0.982	1.012	0.964	0.989	1.189
		30%	0.978	0.978	1.014	0.955	0.986	1.221
		35%	0.974	0.974	1.017	0.947	0.984	1.267
		40%	0.97	0.97	1.02	0.939	0.981	1.31
		45%	0.966	0.966	1.023	0.93	0.978	1.353
	50%	0.961	0.961	1.026	0.92	0.975	1.398	
	Propylene Glycol	5%	0.995	0.995	1.003	0.99	0.997	1.065
		10%	0.99	0.99	1.006	0.98	0.994	1.119
		15%	0.986	0.986	1.009	0.971	0.991	1.152
		20%	0.981	0.981	1.012	0.962	0.988	1.182
		25%	0.978	0.978	1.014	0.956	0.986	1.227
		30%	0.975	0.975	1.016	0.95	0.984	1.267
		35%	0.972	0.972	1.018	0.944	0.982	1.312
		40%	0.969	0.969	1.02	0.938	0.98	1.356
		45%	0.965	0.965	1.023	0.929	0.977	1.402
	50%	0.96	0.96	1.026	0.919	0.974	1.45	

Table Continued on Next Page

# Antifreeze Correction Table

Table Continued from Previous Page

EWT	Antifreeze Type	Antifreeze %	Cooling			Heating		WPD
			Total Cap	Sensible Cap	Watts	Total Cap	Watts	
30	Water	0%	1	1	1	1	1	1
	Ethanol	5%	0.991	0.991	1.006	0.981	0.994	1.14
		10%	0.981	0.981	1.012	0.961	0.988	1.242
		15%	0.973	0.973	1.018	0.944	0.983	1.295
		20%	0.964	0.964	1.024	0.927	0.977	1.343
		25%	0.959	0.959	1.028	0.917	0.974	1.363
		30%	0.954	0.954	1.031	0.907	0.97	1.383
		35%	0.949	0.949	1.035	0.897	0.967	1.468
		40%	0.944	0.944	1.038	0.887	0.964	1.523
		45%	0.94	0.94	1.041	0.88	0.962	1.58
	50%	0.936	0.936	1.043	0.872	0.959	1.639	
	Ethylene Glycol	5%	0.997	0.997	1.002	0.993	0.998	1.04
		10%	0.993	0.993	1.004	0.986	0.996	1.075
		15%	0.99	0.99	1.006	0.98	0.994	1.122
		20%	0.987	0.987	1.008	0.973	0.992	1.163
		25%	0.983	0.983	1.011	0.966	0.99	1.195
		30%	0.979	0.979	1.013	0.958	0.987	1.225
		35%	0.976	0.976	1.016	0.951	0.985	1.279
		40%	0.972	0.972	1.018	0.943	0.982	1.324
		45%	0.969	0.969	1.021	0.937	0.98	1.371
	50%	0.966	0.966	1.023	0.93	0.978	1.419	
	Methanol	5%	0.995	0.995	1.004	0.989	0.997	1.069
		10%	0.989	0.989	1.007	0.978	0.993	1.127
		15%	0.984	0.984	1.011	0.968	0.99	1.164
		20%	0.979	0.979	1.014	0.957	0.986	1.197
		25%	0.975	0.975	1.017	0.949	0.984	1.216
		30%	0.971	0.971	1.019	0.941	0.981	1.235
		35%	0.967	0.967	1.022	0.933	0.979	1.286
		40%	0.963	0.963	1.025	0.924	0.976	1.323
		45%	0.959	0.959	1.028	0.917	0.974	1.36
	50%	0.955	0.955	1.03	0.91	0.971	1.399	
	Propylene Glycol	5%	0.995	0.995	1.004	0.989	0.997	1.071
		10%	0.989	0.989	1.007	0.978	0.993	1.13
		15%	0.985	0.985	1.01	0.968	0.99	1.206
		20%	0.98	0.98	1.013	0.958	0.987	1.27
		25%	0.974	0.974	1.017	0.947	0.983	1.359
		30%	0.968	0.968	1.021	0.935	0.979	1.433
		35%	0.963	0.963	1.025	0.924	0.976	1.522
		40%	0.957	0.957	1.029	0.913	0.972	1.614
		45%	0.949	0.949	1.034	0.898	0.967	1.712
	50%	0.941	0.941	1.039	0.882	0.962	1.816	



# Hybrid Performance Data – Correction Tables

## Blower Motor Correction Table

Size	Hydronic Coil Static
TSL09	0.1
TSL12	0.1
TSL15	0.1
TSL18	0.15
TSL24	0.15
TSL30	0.15
TSL36	0.2

## Airflow Correction Table

% of Nominal (rated) SCFM	Heating Capacity
70	0.8
75	0.8
80	0.9
85	0.9
90	0.9
95	1.0
100	1.0
105	1.0

## Entering Air Correction Table

Entering Air DB (°F)	Heating Capacity
45	1.65
50	1.52
55	1.39
60	1.25
65	1.12
68	1.04
70	1
75	0.85
80	0.72

# Blower Performance Data – TSL09

External Static Pressure (in. wg)											
Speed Tap		0.1	0.2	0.3	0.4	0.5	0.6	0.7	0.8		
<b>PSC - High Static</b>	<b>Low</b>	<b>RPM</b>	1000	1120	1210	1290	1380				
		<b>Power (W)</b>	145	139	132	125	119				
		<b>CFM</b>	350	340	320	290	270				
	<b>Medium</b>	<b>RPM</b>	<b>Operation not recommended</b>				1520	1570	1610	1650	
		<b>Power (W)</b>					162	151	139	127	
		<b>CFM</b>					430	390	340	280	
	<b>High</b>	<b>RPM</b>	<b>Operation not recommended</b>								1710
		<b>Power (W)</b>									151
		<b>CFM</b>									390
<b>Constant Torque ECM</b>	<b>Speed Tap</b>		0.1	0.2	0.3	0.4	0.5	0.6	0.7	0.8	
	<b>1</b>	<b>RPM</b>	980	1080	1170	1260	1360	<b>Operation not recommended</b>			
		<b>Power (W)</b>	47	51	54	58	62				
		<b>CFM</b>	340	320	290	270	240				
	<b>2</b>	<b>RPM</b>	1060	1160	1230	1320	1390	1500	<b>Operation not recommended</b>		
		<b>Power (W)</b>	58	62	66	70	75	79			
		<b>CFM</b>	380	360	330	310	280	260			
	<b>3</b>	<b>RPM</b>	<b>Operation not recommended</b>		1230	1310	1390	1440	1530	1590	1650
		<b>Power (W)</b>			79	84	88	92	97	101	105
		<b>CFM</b>			400	380	360	340	320	290	270
	<b>4</b>	<b>RPM</b>	<b>Operation not recommended</b>			1470	1480	1550	1630	1680	
		<b>Power (W)</b>				108	113	117	122	126	
		<b>CFM</b>				410	390	370	360	340	
	<b>Constant Volume ECM</b>	<b>CFM</b>		0.1	0.2	0.3	0.4	0.5	0.6	360	340
		<b>250</b>	<b>RPM</b>	810	950	1100	1230	1370	1490	1560	1640
<b>Power (W)</b>			30	38	47	57	67	78	89	101	
<b>300</b>		<b>RPM</b>	900	1050	1180	1300	1410	1520	1590	1660	
		<b>Power (W)</b>	38	48	58	69	81	93	105	118	
<b>350</b>		<b>RPM</b>	1000	1140	1260	1380	1450	1540	1620	1690	
		<b>Power (W)</b>	50	62	73	85	98	110	124	137	
<b>400</b>		<b>RPM</b>	1100	1230	1340	1450	1490	1570	<b>Operation not recommended</b>		
		<b>Power (W)</b>	65	79	92	105	119	132			

All data is presented as lowest of nameplate voltage.  
 All data is shown wet coil with clean 1" filter.  
 All data is ran at 80°F DB and 67°F WB.  
 CFM Tolerance is 7%  
 RPM/Watt Tolerance 10%

# Blower Performance Data – TSL12

External Static Pressure (in. wg)											
Speed Tap		0.1	0.2	0.3	0.4	0.5	0.6	0.7	0.8		
PSC - High Static	Low	RPM	980	1090	1190	Operation not recommended					
		Power (W)	145	139	132						
		CFM	350	340	320						
	Medium	RPM		1290	1360	1440	1470	1540	1590		
		Power (W)		197	185	174	162	151	139		
		CFM		500	480	460	430	390	340		
	High	RPM	Operation not recommended					1590	1630	1680	
		Power (W)	Operation not recommended					151	151	151	
		CFM	Operation not recommended					520	470	390	
Constant Torque ECM	Speed Tap		0.1	0.2	0.3	0.4	0.5	0.6	0.7	0.8	
	1	RPM	1070	1140	1230	1320	1400	Operation not recommended			
		Power (W)	66	70	74	78	82				
		CFM	410	380	360	330	310				
	2	RPM	1140	1190	1280	1370	1430	1510	1580		
		Power (W)	54	58	61	65	69	73	77		
		CFM	450	420	400	380	360	330	310		
	3	RPM	1190	1240	1320	1400	1450	1530	1590	1660	
		Power (W)	79	83	87	91	96	100	104	108	
		CFM	480	460	440	420	400	370	350	330	
	4	RPM	Operation not recommended					1580	1630	1690	
		Power (W)	Operation not recommended					137	141	145	
		CFM	Operation not recommended					480	460	440	
	Constant Volume ECM	CFM		0.1	0.2	0.3	0.4	0.5	0.6	0.7	0.8
		300	RPM	890	1040	1170	1300	1400	1500	1570	1660
Power (W)			38	48	58	69	81	93	105	118	
350		RPM	980	1100	1220	1340	1430	1520	1590	1670	
		Power (W)	50	62	73	85	98	110	124	137	
400		RPM	1060	1170	1280	1380	1450	1540	Operation not recommended		
		Power (W)	65	79	92	105	119	132			
450		RPM	1140	1230	1330	1430	Operation not recommended				
		Power (W)	87	101	115	128					
500		RPM	1220	Operation not recommended							
	Power (W)	111									

All data is presented as lowest of nameplate voltage.  
 All data is shown wet coil with clean 1" filter.  
 All data is ran at 80°F DB and 67°F WB.  
 CFM Tolerance is 7%  
 RPM/Watt Tolerance 10%

# Blower Performance Data – TSL15

External Static Pressure (in. wg)											
Speed Tap		0.1	0.2	0.3	0.4	0.5	0.6	0.7	0.8		
<b>PSC - High Static</b>	<b>Low</b>	<b>RPM</b>	860	890	900	950	990	1050			
		<b>Power (W)</b>	219	208	197	186	175	164			
		<b>CFM</b>	700	660	610	570	520	480			
	<b>Medium</b>	<b>RPM</b>			960	1010	1030	1070	1590		
		<b>Power (W)</b>			225	212	200	187	139		
		<b>CFM</b>			710	670	610	540	340		
	<b>High</b>	<b>RPM</b>					1080	1110	1140	1680	
		<b>Power (W)</b>			<b>Operation not recommended</b>			248	233	219	151
		<b>CFM</b>					720	630	530	390	
<b>Constant Torque ECM</b>	<b>Speed Tap</b>		<b>0.1</b>	<b>0.2</b>	<b>0.3</b>	<b>0.4</b>	<b>0.5</b>	<b>0.6</b>	<b>0.7</b>	<b>0.8</b>	
	<b>1</b>	<b>RPM</b>	720	770	810	870					
		<b>Power (W)</b>	66	70	74	79					
		<b>CFM</b>	560	520	480	430					
	<b>2</b>	<b>RPM</b>	770	810	850	910	960				
		<b>Power (W)</b>	79	83	87	92	98				
		<b>CFM</b>	610	570	540	500	450				
	<b>3</b>	<b>RPM</b>	820	860	890	930	990	1040			
		<b>Power (W)</b>	95	101	104	110	114	121			
		<b>CFM</b>	660	630	600	540	500	460			
	<b>4</b>	<b>RPM</b>	850	900	910	970	1010	1070	1120		
		<b>Power (W)</b>	107	111	117	123	128	134	141		
		<b>CFM</b>	690	670	630	600	560	520	470		
	<b>5</b>	<b>RPM</b>			960	1010	1050	1100	1150	1210	
		<b>Power (W)</b>			142	147	153	159	166	167	
		<b>CFM</b>			710	670	640	600	560	510	
	<b>Constant Volume ECM</b>	<b>CFM</b>		<b>0.1</b>	<b>0.2</b>	<b>0.3</b>	<b>0.4</b>	<b>0.5</b>	<b>0.6</b>	<b>0.7</b>	<b>0.8</b>
		<b>450</b>	<b>RPM</b>	620	700	790	880	960	1040	1110	1190
<b>Power (W)</b>			39	53	67	82	96	110	124	139	
<b>500</b>		<b>RPM</b>	670	750	830	910	990	1060	1130	1210	
		<b>Power (W)</b>	50	64	78	93	107	121	135	150	
<b>600</b>		<b>RPM</b>	760	840	890	970	1030	1100	1160	1230	
		<b>Power (W)</b>	83	97	111	125	139	153	167	181	
<b>650</b>		<b>RPM</b>	810	880	920	1000	1050	1120	1180	1250	
		<b>Power (W)</b>	104	118	133	147	162	176	191	205	
<b>700</b>		<b>RPM</b>	860	930	960	1030	1070	1140	1200	1260	
		<b>Power (W)</b>	125	140	155	170	185	199	214	229	

All data is presented as lowest of nameplate voltage.  
 All data is shown wet coil with clean 1" filter.  
 All data is ran at 80°F DB and 67°F WB.  
 CFM Tolerance is 7%  
 RPM/Watt Tolerance 10%

# Blower Performance Data – TSL18

External Static Pressure (in. wg)											
Speed Tap		0.1	0.2	0.3	0.4	0.5	0.6	0.7	0.8		
<b>PSC - High Static</b>	<b>Low</b>	<b>RPM</b>			1030	1090	1110	1120	1130		
		<b>Power (W)</b>			246	235	223	212	200		
		<b>CFM</b>			760	710	650	580	510		
	<b>Medium</b>	<b>RPM</b>				1130	1130	1140	1140		
		<b>Power (W)</b>				251	239	228	216		
		<b>CFM</b>				750	680	610	530		
	<b>High</b>	<b>RPM</b>	<b>Operation not recommended</b>				1180	1180	1170		
		<b>Power (W)</b>					282	270	258		
		<b>CFM</b>					740	660	570		
<b>Constant Torque ECM</b>	<b>Speed Tap</b>		<b>0.1</b>	<b>0.2</b>	<b>0.3</b>	<b>0.4</b>	<b>0.5</b>	<b>0.6</b>	<b>0.7</b>	<b>0.8</b>	
	<b>1</b>	<b>RPM</b>	750	800	850	880	<b>Operation not recommended</b>				
		<b>Power (W)</b>	73	77	82	87					
		<b>CFM</b>	590	550	500	450					
	<b>2</b>	<b>RPM</b>	820	860	910	960	990	1030			
		<b>Power (W)</b>	95	99	105	110	115	119			
		<b>CFM</b>	660	630	590	540	500	460			
	<b>3</b>	<b>RPM</b>	890	930	960	1040	1060	1090	1130	1200	
		<b>Power (W)</b>	123	127	132	138	144	149	154	158	
		<b>CFM</b>	730	700	670	640	590	550	520	490	
	<b>4</b>	<b>RPM</b>			970	1000	1080	1110	1140	1170	1220
		<b>Power (W)</b>			148	152	158	164	170	176	172
		<b>CFM</b>			750	720	690	660	610	570	520
	<b>5</b>	<b>RPM</b>	<b>Operation not recommended</b>					1230	1180	1180	
		<b>Power (W)</b>						217	182	154	
		<b>CFM</b>						730	580	470	
	<b>Constant Volume ECM</b>	<b>CFM</b>		<b>0.1</b>	<b>0.2</b>	<b>0.3</b>	<b>0.4</b>	<b>0.5</b>	<b>0.6</b>	<b>0.7</b>	<b>0.8</b>
		<b>500</b>	<b>RPM</b>	660	750	850	920	990	1060	1120	1200
<b>Power (W)</b>			52	67	81	96	110	125	139	153	
<b>600</b>		<b>RPM</b>	760	840	920	1010	1070	1130	1200	1270	
		<b>Power (W)</b>	88	102	116	130	144	158	172	186	
<b>700</b>		<b>RPM</b>	860	930	980	1090	1150	1210	1280	1340	
		<b>Power (W)</b>	138	153	167	182	196	211	225	240	
<b>800</b>		<b>RPM</b>	960	1010	1050	1170	1220	1280	1360	1400	
		<b>Power (W)</b>	199	216	232	249	265	282	298	315	

All data is presented as lowest of nameplate voltage.  
 All data is shown wet coil with clean 1" filter.  
 All data is ran at 80°F DB and 67°F WB.  
 CFM Tolerance is 7%  
 RPM/Watt Tolerance 10%

# Blower Performance Data – TSL24

External Static Pressure (in. wg)																	
		Speed Tap	0.1	0.2	0.3	0.4	0.5	0.6	0.7	0.8							
<b>PSC - High Static</b>	Low	RPM	Operation not recommended			900	940	980	1020	1070							
		Power (W)				311	295	279	263	246							
		CFM				940	880	810	720	630							
	Medium	RPM				Operation not recommended			980	1010	1040	1080					
		Power (W)							325	305	285	265					
		CFM							980	900	800	690					
	High	RPM							Operation not recommended							1110	
		Power (W)														343	
		CFM														890	
<b>Constant Torque ECM</b>	Speed Tap		0.1	0.2	0.3							0.4	0.5	0.6	0.7	0.8	
	1	RPM	680	720	770							820	870	930			
		Power (W)	110	117	123							131	138	146			
		CFM	840	800	760	720	670	630									
	2	RPM	730	770	810	860	910	960				1020	1080				
		Power (W)	145	153	160	167	175	183				192	199				
		CFM	940	900	860	830	790	750	710	670							
	3	RPM	Operation not recommended			900	950	1000	1050	1100							
		Power (W)				212	219	227	236	246							
		CFM				940	900	870	830	790							
	4	RPM				Operation not recommended							1080	1120			
		Power (W)											285	294			
		CFM											940	900			
	5	RPM							Operation not recommended								
		Power (W)															
		CFM															
	<b>Constant Volume ECM</b>	CFM		0.1	0.2							0.3	0.4	0.5	0.6	0.7	0.8
		600	RPM	560	630							710	780	840	920	990	1070
Power (W)			52	70	87							104	122	139	157	174	
700		RPM	610	680	750	820	880	950				1020	1080				
		Power (W)	77	96	115	134	153	172				191	210				
800		RPM	660	720	790	850	910	980				1040	1100				
		Power (W)	102	122	143	164	184	205	226	246							
900		RPM	710	770	830	890	950	1010	1070	1120							
		Power (W)	134	155	176	197	218	239	261	282							
950		RPM	740	790	850	900	970	1020	1080	1120							
		Power (W)	172	193	214	234	255	276	296	317							

All data is presented as lowest of nameplate voltage.  
 All data is shown wet coil with clean 1" filter.  
 All data is ran at 80°F DB and 67°F WB.  
 CFM Tolerance is 7%  
 RPM/Watt Tolerance 10%

# Blower Performance Data – TSL30

External Static Pressure (in. wg)											
Speed Tap		0.1	0.2	0.3	0.4	0.5	0.6	0.7	0.8		
<b>PSC - High Static</b>	<b>Low</b>	<b>RPM</b>	800	840	880	920	950	980			
		<b>Power (W)</b>	360	344	328	311	295	279			
		<b>CFM</b>	1020	1010	980	940	880	810			
	<b>Medium</b>	<b>RPM</b>	870	910	940	980	1000	1020	1040		
		<b>Power (W)</b>	405	385	365	345	325	305	285		
		<b>CFM</b>	1130	1120	1080	1040	980	900	800		
	<b>High</b>	<b>RPM</b>	<b>Operation not recommended</b>					1120	1120	1130	
		<b>Power (W)</b>	<b>Operation not recommended</b>					395	369	343	
		<b>CFM</b>	<b>Operation not recommended</b>					1120	1010	890	
<b>Constant Torque ECM</b>	<b>Speed Tap</b>		<b>0.1</b>	<b>0.2</b>	<b>0.3</b>	<b>0.4</b>	<b>0.5</b>	<b>0.6</b>	<b>0.7</b>	<b>0.8</b>	
	<b>1</b>	<b>RPM</b>	810	840	870	910	950	1000	1050	1090	
		<b>Power (W)</b>	177	185	194	203	212	221	229	236	
		<b>CFM</b>	1040	1000	960	920	880	850	810	770	
	<b>2</b>	<b>RPM</b>	850	890	920	960	990	1040	1090	1130	
		<b>Power (W)</b>	220	229	237	247	257	266	275	283	
		<b>CFM</b>	1110	1080	1050	1010	970	940	910	880	
	<b>3</b>	<b>RPM</b>	<b>Operation not recommended</b>				1070	1110	1150	1180	
		<b>Power (W)</b>	<b>Operation not recommended</b>				351	363	373	384	
		<b>CFM</b>	<b>Operation not recommended</b>				1140	1100	1070	1040	
	<b>4</b>	<b>RPM</b>	<b>Operation not recommended</b>						1190	1220	
		<b>Power (W)</b>	<b>Operation not recommended</b>						442	451	
		<b>CFM</b>	<b>Operation not recommended</b>						1170	1140	
	<b>5</b>	<b>RPM</b>	<b>Operation not recommended</b>								
		<b>Power (W)</b>	<b>Operation not recommended</b>								
		<b>CFM</b>	<b>Operation not recommended</b>								
	<b>Constant Volume ECM</b>	<b>CFM</b>		<b>0.1</b>	<b>0.2</b>	<b>0.3</b>	<b>0.4</b>	<b>0.5</b>	<b>0.6</b>	<b>0.7</b>	<b>0.8</b>
		<b>750</b>	<b>RPM</b>	620	690	750	810	890	960	1030	1080
<b>Power (W)</b>			85	109	133	157	182	206	230	254	
<b>875</b>			<b>RPM</b>	700	760	820	880	950	1010	1070	
<b>1000</b>		<b>Power (W)</b>	131	157	183	209	235	261	287	313	
		<b>RPM</b>	780	840	890	950	1010	1070	1120	1170	
<b>1150</b>		<b>Power (W)</b>	191	219	247	275	303	331	359	387	
		<b>RPM</b>	880	930	980	1040	1080	1130	1180	1220	
		<b>Power (W)</b>	284	310	336	361	387	413	438	464	

All data is presented as lowest of nameplate voltage.  
 All data is shown wet coil with clean 1" filter.  
 All data is ran at 80°F DB and 67°F WB.  
 CFM Tolerance is 7%  
 RPM/Watt Tolerance 10%



# Blower Performance Data – TSL36

External Static Pressure (in. wg)											
Speed Tap		0.1	0.2	0.3	0.4	0.5	0.6	0.7	0.8		
<b>PSC - High Static</b>	<b>Low</b>	<b>RPM</b>	730	770	820						
		<b>Power (W)</b>	378	358	338						
		<b>CFM</b>	930	920	900						
	<b>Medium</b>	<b>RPM</b>	910	950	970	1000	1020	1040			
		<b>Power (W)</b>	485	459	432	405	379	352			
		<b>CFM</b>	1210	1190	1150	1100	1030	950			
	<b>High</b>	<b>RPM</b>			1100	1120	1120	1130	1130	1130	
		<b>Power (W)</b>			529	501	472	444	415	386	
		<b>CFM</b>			1370	1310	1230	1130	1020	900	
<b>Constant Torque ECM</b>	<b>Speed Tap</b>		<b>0.1</b>	<b>0.2</b>	<b>0.3</b>	<b>0.4</b>	<b>0.5</b>	<b>0.6</b>	<b>0.7</b>	<b>0.8</b>	
	<b>1</b>	<b>RPM</b>	830	860	890	930	970	1020			
		<b>Power (W)</b>	193	201	211	221	231	239			
		<b>CFM</b>	1080	1050	1020	980	950	910			
	<b>2</b>	<b>RPM</b>	920	950	970	1010	1060	1090	1140	1170	
		<b>Power (W)</b>	265	273	282	294	305	316	326	335	
		<b>CFM</b>	1220	1190	1150	1130	1100	1060	1030	1000	
	<b>3</b>	<b>RPM</b>	1020	1040	1070	1110	1140	1180	1220	1250	
		<b>Power (W)</b>	361	369	377	387	401	414	426	428	
		<b>CFM</b>	1370	1340	1310	1290	1260	1230	1200	1160	
	<b>4</b>	<b>RPM</b>	940	970	1010	1050	1070	1150			
		<b>Power (W)</b>	315	322	332	341	351	430			
		<b>CFM</b>	1240	1230	1200	1170	1140	1200			
	<b>5</b>	<b>RPM</b>									
		<b>Power (W)</b>									
		<b>CFM</b>									
	<b>Constant Volume ECM</b>	<b>CFM</b>		<b>0.1</b>	<b>0.2</b>	<b>0.3</b>	<b>0.4</b>	<b>0.5</b>	<b>0.6</b>	<b>0.7</b>	<b>0.8</b>
		<b>900</b>	<b>RPM</b>	710	760	820	880	950	1020	1070	1130
<b>Power (W)</b>			132	157	183	208	234	260	285	311	
<b>CFM</b>			900	900	900	900	900	900	900	900	
<b>1050</b>		<b>RPM</b>	810	860	910	970	1030	1090	1150	1200	
		<b>Power (W)</b>	215	244	272	301	329	358	386	415	
<b>1200</b>		<b>RPM</b>	910	950	1000	1050	1110	1160	1220	1260	
		<b>Power (W)</b>	299	331	362	393	425	456	487	519	
<b>1350</b>		<b>RPM</b>	1000	1050	1090	1140	1190	1240	1290	1330	
		<b>Power (W)</b>	458	483	509	534	560	585	611	636	

All data is presented as lowest of nameplate voltage.  
 All data is shown wet coil with clean 1" filter.  
 All data is ran at 80°F DB and 67°F WB.  
 CFM Tolerance is 7%  
 RPM/Watt Tolerance 10%

# Performance Data – Ducted CV ECM

All data wet coil clean filter.

Tranquility Model	Setting	Cooling Mode		Heating Mode		Dehumid Mode		Continuous Fan Only Mode
		Fan Motor Stage 1	Fan Motor Stage 2*	Fan Motor Stage 1	Fan Motor Stage 2*	Fan Motor Stage 1	Fan Motor Stage 2*	
TSL09	Default	250	350	250	350	250	300	250
	Min	250	250	250	250	250	250	250
	Max	400	400	400	400	400	400	400
TSL12	Default	300	400	300	400	300	350	300
	Min	300	300	300	300	300	300	300
	Max	500	500	500	500	500	500	500
TSL15	Default	500	600	500	600	500	500	500
	Min	500	500	500	500	500	500	500
	Max	700	700	700	700	700	700	700
TSL18	Default	600	700	600	700	600	600	500
	Min	600	600	600	600	500	500	500
	Max	800	800	800	800	800	800	800
TSL24	Default	650	850	650	850	650	650	600
	Min	650	650	650	650	600	600	600
	Max	950	950	950	950	950	950	950
TSL30	Default	850	1000	900	1000	850	850	700
	Min	850	850	900	900	800	800	700
	Max	1100	1100	1100	1100	900	1100	1100
TSL36	Default	900	1200	900	1250	900	900	900
	Min	900	900	900	900	900	900	900
	Max	1250	1250	1350	1350	1250	1250	1250

All units AHRI/ISO/ASHRAE 13256-1 rated on CFM shown on performance data page.

If unit is dual voltage rated, then the airflow is rated at the lowest voltage, i.e. 208V for 208-230V units.

Shipped on default settings. C=Cooling; H=Heating; D=Dehumidification

Change from default setting with Service tool (ACDU03C) or AWC Communicating Thermostat.

Airflow is controlled within 7%, up to the max ESP.

TSL15-36 ramp default is 30 sec.

\* - Stage 2 CV ECM motor speed is engaged with a thermostat Y2 call. TSL Series is only available with single-stage compressors.

# Physical Data

Model	09	12	15	18	24	30	36
Compressor (1 Each)	Rotary				Scroll		
Factory Charge HFC-410A (oz) [kg]	35 [.99]	35 [.99]	43 [1.22]	53 [1.50]	71 [2.01]	66 [1.87]	75 [2.13]
<b>Motor &amp; Blower</b>							
208-230V PSC (HP) [W]	1/10 [75]	1/10 [75]	1/3 [249]	1/3 [249]	1/3 [249]	1/3 [249]	3/4 [560]
265V PSC (HP) [W]	1/10 [75]	1/10 [75]	1/3 [249]	1/3 [249]	1/2 [373]	1/2 [373]	3/4 [560]
Constant Volume ECM (HP) [W]	1/8 [93]	1/8 [93]	1/3 [249]	1/3 [249]	1/3 [249]	1/2 [373]	3/4 [560]
Constant Torque ECM (HP) [W]	1/4 [186]	1/4 [186]	1/3 [249]	1/3 [249]	1/2 [373]	1/2 [373]	3/4 [560]
Blower Wheel Size (diam x w) - (in) [mm]	6.75 x 7.25 [165 x 184]		9.5 x 7.12 [241 x 180]		10.63 x 8.0 [270 x 203]		
<b>Chassis Air Coil</b>							
Air Coil Dimensions (h x w) - (in) [mm]	28 x 12.625 [711 x 321 ]		28 x 14 [711 x 356]		30 x 18 [762 x 457]		
Return Air Filter Dimensions (h x w) - (in) [mm]	30 x 14 [762 x 356]		30 x 16 [762 x 406]		32 x 20 [813 x 508]		
Coax Volume (Gallons) [Liters]	0.26 [.98]		0.36 [1.4]		0.60 [2.3]		
Hose Size (in)	1/2		3/4		1		
<b>Weight</b>							
Chassis - (lbs) [kg]	110 [50]	117 [53]	123 [56]	125 [57]	186 [84]	190 [86]	192 [87]
65" Cabinet - (lbs) [kg]	95 [43]		108 [49]		142 [64]		

Unit Maximum Water Working Pressure	
Options	Max Pressure PSIG [kPa]
Base Unit (Hoses)	400 [2,757]
Internal Secondary Pump (ISP)	200 [1,378]
Internal Motorized Water Valve (MWV)	300 [2,068]
Internal Modulating Valve	300 [2,068]
Internal Auto Flow Valve	400 [2,757]

Use the lowest maximum pressure rating when multiple options are combined.

\* Units with MWV have 300 [2068] High Pressure Water switch - 250 [1723] Auto Reset

# Hybrid Physical Data

Model	09	12	15	18	24	30	36
Compressor (1 Each)	Rotary				Scroll		
Factory Charge HFC-410A (oz) [kg]	35 [.99]	35 [.99]	43 [1.22]	53 [1.50]	71 [2.01]	66 [1.87]	75 [2.13]
<b>Motor &amp; Blower</b>							
Constant Volume ECM (HP) [W]	1/8 [93]	1/4 [186]	1/3 [249]	1/3 [249]	1/2 [373]	3/4 [560]	3/4 [560]
Constant Torque ECM (HP) [W]	1/4 [186]	1/4 [186]	1/3 [249]	1/3 [249]	1/2 [373]	1/2 [373]	3/4 [560]
Blower Wheel Size (diam x w) - (in) [mm]	6.75 x 7.25 [165 x 184]		9.5 x 7.12 [241 x 180]		10.63 x 8.0 [270 x 203]		
<b>Chassis Air Coil</b>							
Refrigerant Air Coil Dimensions (h x w) - (in) [mm]	28 x 12.625 [711 x 321 ]		28 x 14 [711 x 356]		30 x 18 [762 x 457]		
Hydronic Coil Dimensions (h x w) - (in) [mm]	28 x 12.625 [711 x 321 ]		28 x 14 [711 x 356]		30 x 18 [762 x 457]		
Return Air Filter Dimensions (h x w) - (in) [mm]	30 x 14 [762 x 356]		30 x 16 [762 x 406]		32 x 20 [813 x 508]		
Coax Volume (Gallons) [Liters]	0.26 [.98]		0.36 [1.4]		0.60 [2.3]		
Hydronic Coil Volume (Gallons) [Liters]	0.08 [0.30]		0.61 [2.31]		0.77 [2.91]		
Hose Size (in)	1/2		3/4		1		
<b>Weight</b>							
Chassis - (lbs) [kg]	132 [60]		181 [83]		228 [104]		
65" Cabinet - (lbs) [kg]	116 [53]		128 [58]		139 [63]		
80" Cabinet - (lbs) [kg]	129 [59]		142 [65]		156 [71]		
88" Cabinet - (lbs) [kg]	137 [63]		151 [69]		166 [76]		

Unit Maximum Water Working Pressure	
Options	Max Pressure PSIG [kPa]
Base Unit	400 [2,757]
Hydronic Coil	625 [4,309]
Internal Secondary Pump (ISP)	200 [1,378]
Internal Motorized Water Valve (MWV)	300 [2,068]
Internal Modulating Valve	300 [2,068]
Internal Auto Flow Valve	400 [2,757]

Use the lowest maximum pressure rating when multiple options are combined.

\* Units with MWV have 300 [2068] High Pressure Water switch - 250 [1723] Auto Reset

## Electrical Data – PSC Motor (208/230V) and (265V)

### PSC Motor (208/230V)

Model #	Voltage Code "G"	Compressor		Blower Motor	Pump Option	Total Unit FLA	Min Circuit Amps	Max Fuse Amps
		RLA	LRA	FLA	FLA			
TSL09	208/230-60-1	3.7	22	0.8	0.0	4.5	5.5	15
					0.6	5.2	6.1	15
TSL12		4.6	30	0.8	0.0	5.5	6.6	15
					0.6	6.1	7.3	15
TSL15		5.6	29	1.6	0.0	7.2	8.6	15
					0.6	7.8	9.2	15
TSL18		6.6	33	1.6	0.0	8.2	9.9	15
					0.6	8.8	10.5	15
TSL24		12.8	58.3	2.7	0.0	15.5	18.7	30
					0.6	16.1	19.3	30
TSL30		12.8	64	2.7	0.0	15.5	18.7	30
					0.6	16.1	19.3	30
TSL36	14.1	77	3.0	0.0	17.1	20.6	30	
				0.6	17.7	21.3	35	

### PSC Motor (265V)

Model #	Voltage Code "E"	Compressor		Blower Motor	Pump Option	Total Unit FLA	Min Circuit Amps	Max Fuse Amps
		RLA	LRA	FLA	FLA			
TSL09	265-60-1	3.5	22	0.8	0.0	4.3	5.2	15
					0.6	5.0	5.8	15
TSL12		3.9	23	0.8	0.0	4.7	5.7	15
					0.6	5.3	6.3	15
TSL15		5.0	28	1.6	0.0	6.6	7.8	15
					0.6	7.2	8.5	15
TSL18		5.6	28	1.6	0.0	7.2	8.6	15
					0.6	7.8	9.2	15
TSL24		9.6	54	2.0	0.0	11.6	14.0	20
					0.6	12.2	14.6	20
TSL30		10.9	60	2.0	0.0	12.9	15.6	25
					0.6	13.5	16.3	25
TSL36	12.2	72	2.9	0.0	15.1	18.2	30	
				0.6	15.7	18.8	30	

## Electrical Data – CV ECM Motor (208/230V) and (265V)

### CV ECM Motor (208/230V)

Model #	Voltage Code "G"	Compressor		Blower Motor	Pump Option	Total Unit FLA	Min Circuit Amps	Max Fuse Amps
		RLA	LRA	FLA	FLA			
TSL09	208/230-60-1	3.7	22	1.5	0.0	5.2	6.1	15
					0.6			
TSL12		4.6	30	1.5	0.0	6.1	7.3	15
					0.6			
TSL15		5.6	29	2.6	0.0	8.2	9.6	15
					0.6			
TSL18		6.6	33	2.6	0.0	9.2	10.9	15
					0.6			
TSL24		12.8	58.3	2.6	0.0	15.4	18.6	30
					0.6			
TSL30		12.8	64	3.9	0.0	16.7	19.9	30
					0.6			
TSL36	14.1	77	5.2	0.0	19.3	22.8	35	
				0.6				19.9

### CV ECM Motor (265V)

Model #	Voltage Code "E"	Compressor		Blower Motor	Pump Option	Total Unit FLA	Min Circuit Amps	Max Fuse Amps
		RLA	LRA	FLA	FLA			
TSL09	265-60-1	3.5	22	1.4	0.0	4.9	5.8	15
					0.6			
TSL12		3.9	23	1.4	0.0	5.3	6.2	15
					0.6			
TSL15		5.0	28	2.1	0.0	7.1	8.4	15
					0.6			
TSL18		5.6	28	2.1	0.0	7.7	9.1	15
					0.6			
TSL24		9.6	54	2.1	0.0	11.7	14.1	20
					0.6			
TSL30		10.9	60	3.2	0.0	14.1	16.8	25
					0.6			
TSL36	12.2	72	4.7	0.0	16.9	20.0	30	
				0.6				17.5

## Electrical Data – CT ECM Motor (208/230V) and (265V)

### CT ECM Motor (208/230V)

Model #	Voltage Code "G"	Compressor		Blower Motor	Pump Option	Total Unit FLA	Min Circuit Amps	Max Fuse Amps
		RLA	LRA	FLA	FLA			
TSL09	208/230-60-1	3.7	22	2.3	0.0	6.0	6.9	15
					0.6			
TSL12		4.6	30	2.3	0.0	6.9	8.1	15
					0.6			
TSL15		5.6	29	2.5	0.0	8.1	9.5	15
					0.6			
TSL18		6.6	33	2.5	0.0	9.1	10.8	15
					0.6			
TSL24		12.8	58.3	4.3	0.0	17.1	20.3	30
					0.6			
TSL30		12.8	64	4.3	0.0	17.1	20.3	30
					0.6			
TSL36	14.1	77	6.1	0.0	20.2	23.7	35	
				0.6				20.8

### CT ECM Motor (265V)

Model #	Voltage Code "E"	Compressor		Blower Motor	Pump Option	Total Unit FLA	Min Circuit Amps	Max Fuse Amps
		RLA	LRA	FLA	FLA			
TSL09	265-60-1	3.5	22	2.3	0.0	5.8	6.7	15
					0.6			
TSL12		3.9	23	2.3	0.0	6.2	7.1	15
					0.6			
TSL15		5.0	28	2.5	0.0	7.5	8.8	15
					0.6			
TSL18		5.6	28	2.5	0.0	8.1	9.5	15
					0.6			
TSL24		9.6	54	4.3	0.0	13.9	16.3	25
					0.6			
TSL30		10.9	60	4.3	0.0	15.2	17.9	25
					0.6			
TSL36	12.2	72	6.1	0.0	18.3	21.4	30	
				0.6				18.9



# TSL Series Wiring Diagram Matrix

All current diagrams can be located online at [climatemaster.com](http://climatemaster.com). Click 'Commercial Professional'.

1. Click 'Products' in the main navigation
2. Select 'Vertical Stack Series'
3. Select the TSL product series
4. Click the Wire Diagrams tab in the middle of the page
5. Select your voltage and controls

Electrical V/Hz/Ph: 208-230/60/1								
T-Stat	Non-Communicating							
Unit Controller	CXM2			DXM2.5				
Fan Motor	PSC	CT ECM		PSC	CT ECM		CV ECM	
Unit Size	09-36	09-12	15-36	15-36	9-12	15-36	9-12	15-36
STD/MWV (N.C.)/ISP	96B0434N01	96B0434N02	96B0434N05	96B0413N41	96B0413N62	96B0413N63	96B0413N43	96B0413N44
MWV (N.O.)	96B0434N03	96B0434N04	96B0434N06	96B0418N04	96B0413N66	96B0413N67	96B0418N01	96B0418N02
3-Way MWV	96B0434N08	96B0434N09	96B0434N07	96B0413N87	96B0413N92	96B0413N93	96B0413N90	96B0413N91
MOD VALVE				96B0413N05	96B0413N68	96B0413N69	96B0413N06	96B0413N07
HYBRID MWV N.C.		96B0434N10	96B0434N13		96B0433N11	96B0433N12	96B0433N09	96B0433N10
HYBRID MWV N.O.		96B0434N11	96B0434N14		96B0433N13	96B0433N14	96B0433N15	96B0433N16
HYBRID 3-WAY VALVE		96B0434N12	96B0434N15		96B0433N27	96B0433N28	96B0433N25	96B0433N26
HYBRID 3-WAY VALVE w/ ISP		96B0434N12	96B0434N15		96B0433N17	96B0433N18	96B0433N25	96B0433N26

Electrical V/Hz/Ph: 208-230/60/1					
T-Stat	Communicating				
Unit Controller	DXM2.5				
Fan Motor	PSC	CT ECM		CV ECM	
Unit Size	9-36	9-12	15-36	9-12	15-36
STD/MWV (N.C.)/ISP	96B0413N54	96B0413N74	96B0413N75	96B0413N55	96B0413N56
MWV (N.O.)	96B0418N14	96B0413N76	96B0413N77	96B0413N15	96B0413N16
3-Way MWV	96B0413N94	96B0413N97	96B0413N98	96B0413N95	96B0413N96
MOD VALVE	96B0413N19	96B0413N78	96B0413N79	96B0413N17	96B0413N18
HYBRID MWV N.C.		96B0433N07	96B0433N08	96B0433N05	96B0433N06
HYBRID MWV N.O.		96B0433N31	96B0433N32	96B0433N29	96B0433N30
HYBRID 3-WAY VALVE		96B0433N23	96B0433N24	96B0433N21	96B0433N22
HYBRID 3-WAY VALVE w/ ISP		96B0433N23	96B0433N24	96B0433N21	96B0433N22

# Standard Unit – Exploded View

## MAJOR COMPONENTS

### 1. TSL Cabinet (Furred-in)

- A – Floating condensate drain pan
- B – Drain P trap
- C – Optional disconnect/breaker location
- D – Upper control box (high voltage terminal blocks optional MPC)
- E – Blower assembly/motor
- F – Risers (not shown)
- G – Shutoffs (not shown)
- H – Filter panel
- I – Filter

- D – Capacitor
- E – High and low voltage locking quick connectors
- F – Air coil
- G – Service Connection

### 3. Architectural Acoustic Return Air Panel (G)

- A – Frame
- B – Hinged inner panel

### 4. Hoses (Not Shown)

### 5. Supply Air Grille (Not Shown)

### 6. Thermostat (Not Shown)

### 2. TSL Chassis

- A – Compressor with acoustic enclosure, water coil, reversing valve
- B – Data plate
- C – Lower control box (transformer, CXM2/DXM2.5, contactor)

**Note:** Matching labels for visual aid, chassis and cabinet same size and voltage



# Hybrid Unit – Exploded View

## MAJOR COMPONENTS

### 1. TSL Cabinet (Furred-in)

- A – Floating condensate drain pan
- B – Drain P trap
- C – Supply air plenum
- D – Optional surface mount thermostat 2 x 4 box horizontal
- E – Optional disconnect/breaker location
- F – Upper control box (high voltage terminal blocks optional MPC)
- G – Blower assembly/motor
- H – Risers (not shown)
- I – Shutoffs (not shown)
- J – Filter panel
- K – Filter

### 2. TSL Chassis

- A – Compressor with acoustic enclosure, water coil, reversing valve
- B – Data plate

- C – Lower control box (transformer, CXM2/DXM2.5, contactor)
- D – Capacitor
- E – High and low voltage locking quick connectors
- F – Air coil
- G – Service Connection

### 3. Architectural Acoustic Return Air Panel (G)

- A – Frame
- B – Hinged inner panel

### 4. Hoses (Not Shown)

### 5. Supply Air Grille (Not Shown)

### 6. Thermostat (Not Shown)

**Note:** Matching labels for visual aid, chassis and cabinet same size and voltage



# D Cabinet

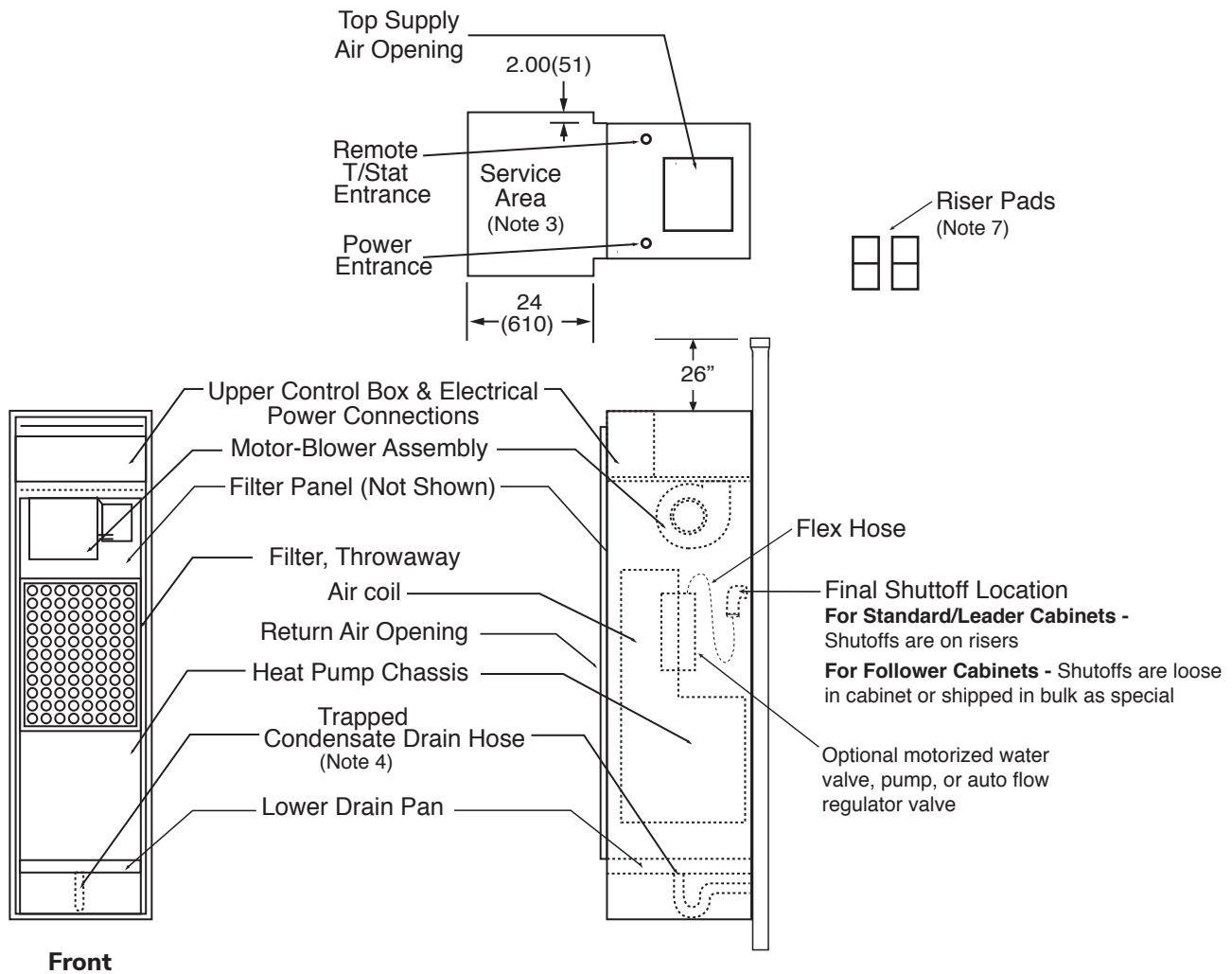

## Notes:

1. All dimensions are in inches (mm).
2. The return air/control box side is defined as front of cabinet. Riser K.O.'s are on all panels.
3. Service area from finished wall and 4" wider than cabinet.
4. Contractor to supply ductwork, see blower table for maximum static.
5. Installer must apply riser pads to outside of cabinet to seal supply and return slots.

⚠ **NOTICE!** ⚠

**Design all ductwork in accordance with SMACNA guidelines.**

# Leader/Follower Cabinet

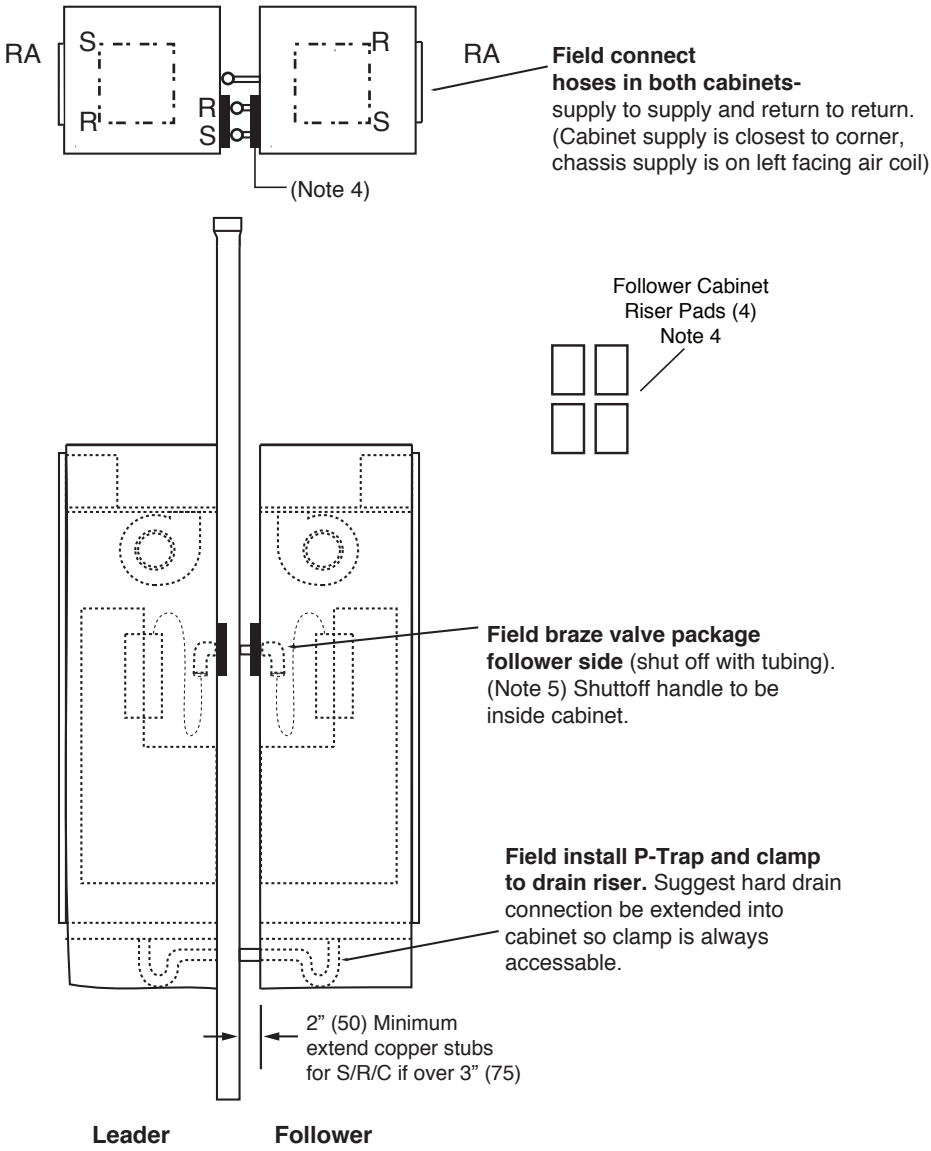

**Notes:**

1. Contractor must meet all fire and building code requirements.
2. Size riser diameter for both units GPM.
3. Leader/Follower means both units share common riser.
4. Install pads on back of follower cabinet to cover slots used for S/R risers.
5. Installer must provide crossover water piping from riser to follower unit. Piping must have same pressure rating or higher as riser.
6. All dimensions are in inches (mm).

**When cabinets are pushed up to risers allow sufficient clearance. Shutoffs should be inside cabinet.**

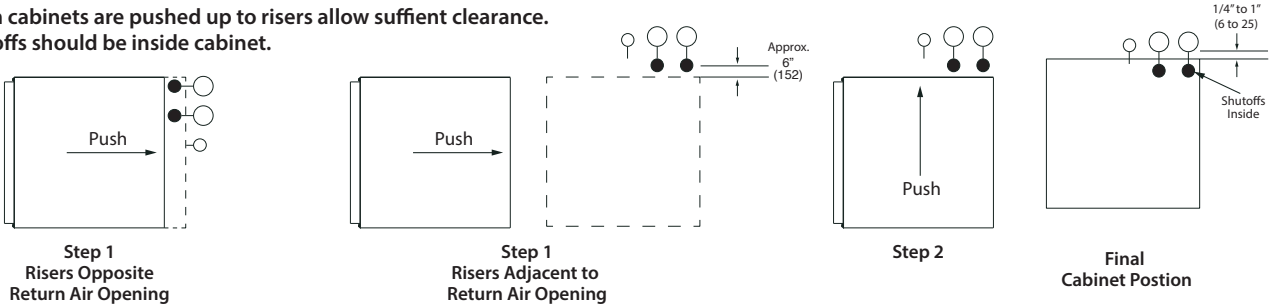

ClimateMaster works continually to improve its products. As a result, the design and specifications of each product at the time of order may be changed without notice and may not be as described herein. Please contact ClimateMaster's Customer Service Department at 1-405-745-6000 for specific information on the current design and specifications. Statements and other information contained herein are not express warranties and do not form the basis of any bargain between the parties, but are merely ClimateMaster's opinion or commendation of its products. The latest version of this document is available at [climatemaster.com](http://climatemaster.com). © ClimateMaster, Inc. All rights reserved 2014

# D Cabinet Dimensions

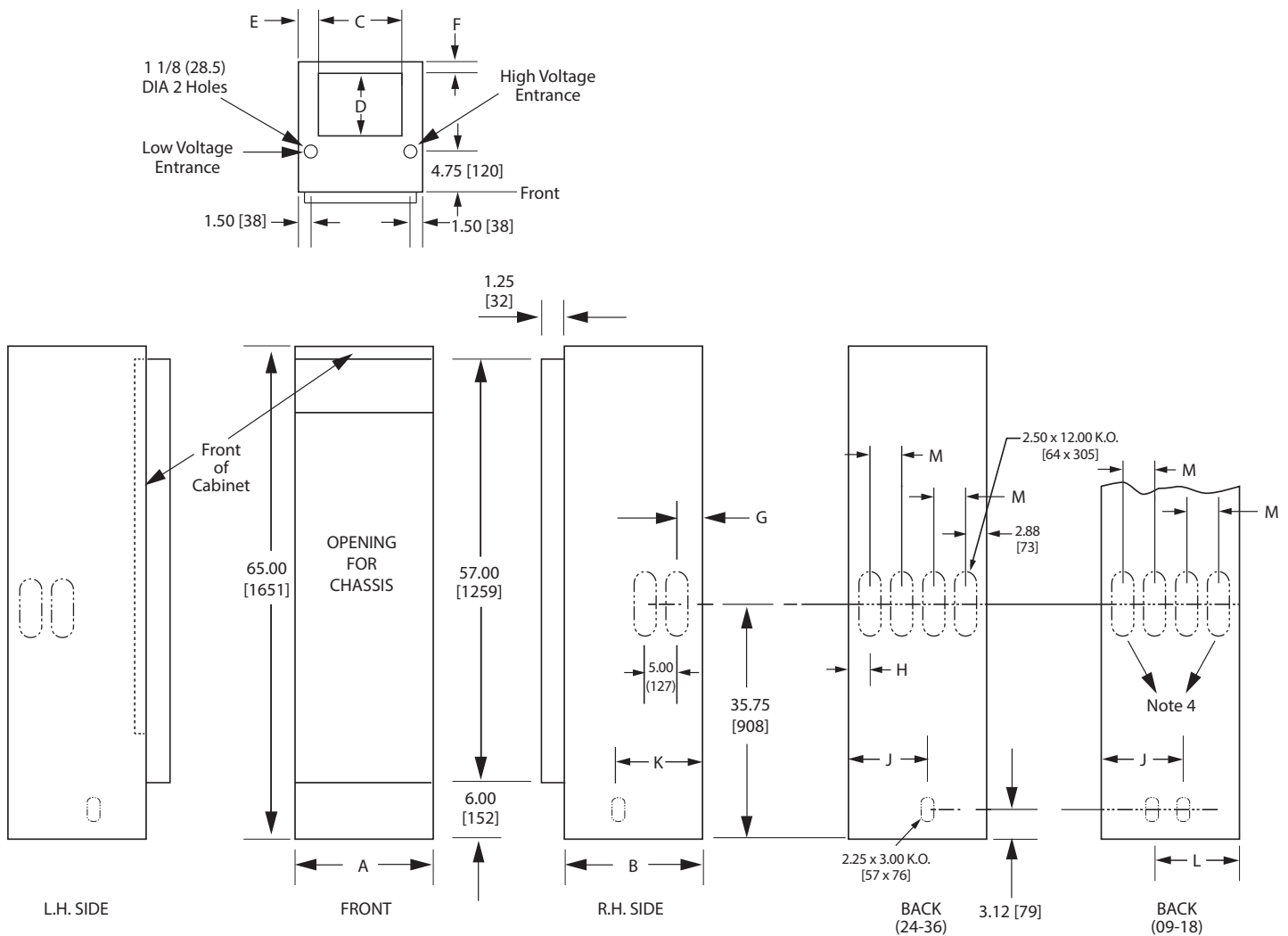

## Notes:

1. All dimensions are in inches (mm).
2. Cabinets have riser K.O.'s, all panels. Remove only K.O.'s necessary to configure cabinet. Seal any K.O.'s removed by mistake.
3. Service area to be width of cabinet and 24" [610] from finished wall.
4. For 09-18 cabinet use drain diagonally across from supply and return risers.
5. Cabinet model digits 11 and 12 will be E0.

Size	A	B	C	D	E	F	G	H	J	K	L	M
09-12	17.00 [432]	17.00 [432]	11.50 [292]	6.00 [152]	2.62 [67]	.665 [17]	2.75 [70]	1.71 [44]	11.34 [288]	11.93 [303]	11.34 [288]	4.63 [117]
15-18	19.25 [489]	19.00 [483]	11.50 [292]	6.00 [152]	3.87 [93]	.665 [17]	2.75 [70]	2.83 [72]	12.08 [307]	11.93 [303]	12.08 [307]	4.63 [117]
24-36	24.25 [616]	24.00 [610]	12.00 [305]	12.00 [305]	6.12 [156]	1.04 [26]	2.73 [69]	2.83 [72]	12.08 [307]	11.98 [304]	N/A	5.00 [127]



# D Cabinet Slot Dimensions and Riser Arrangements

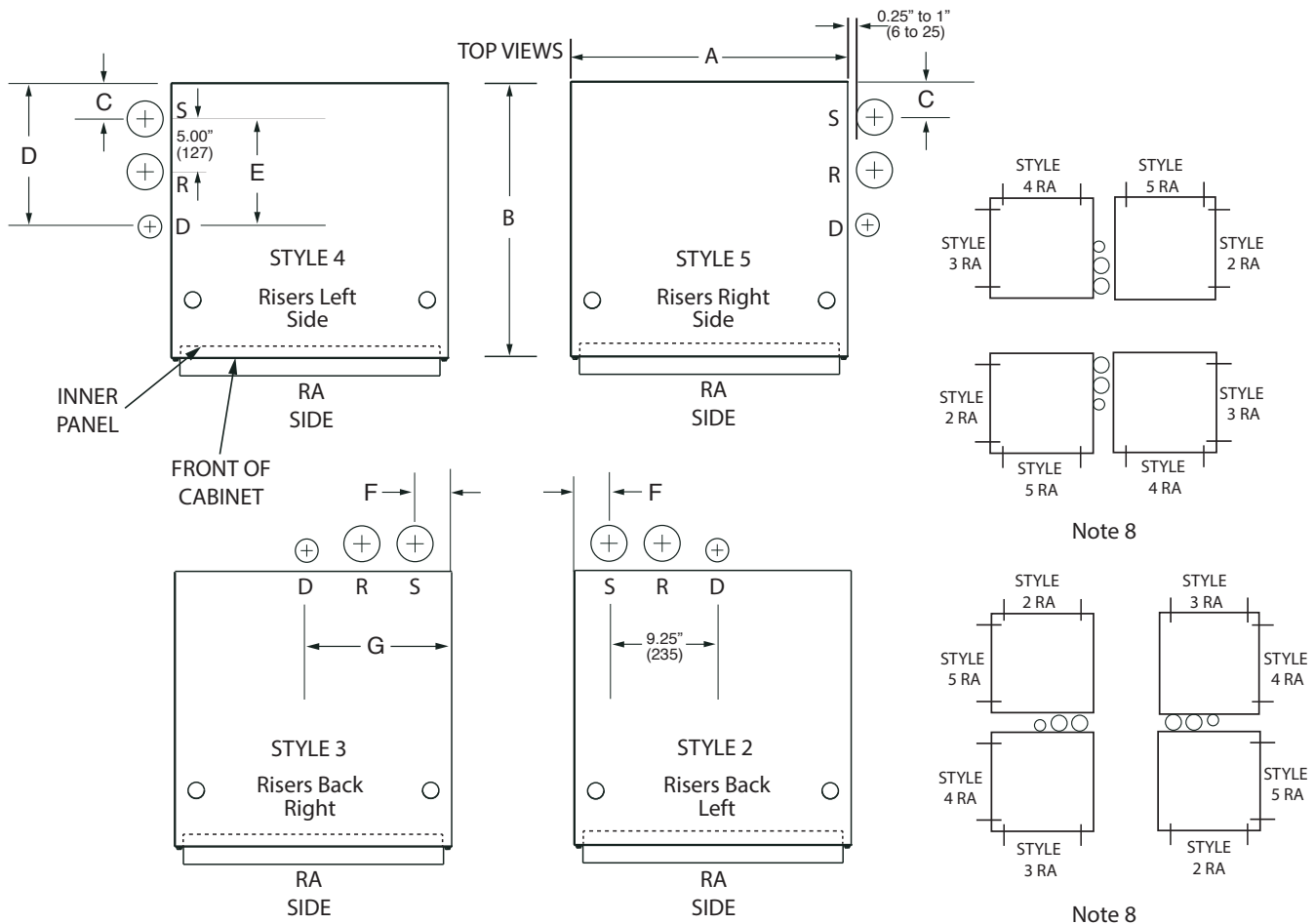

**NOTICE!** Not all styles will stack above or adjacent to each other. (See Note 8).

- Notes:**
1. Dimensions are inches [mm].
  2. Style refers to cabinet model digit 9 - riser location.
  3. Return air side is the front of the cabinet.
  4. Supply riser is closest to corner.
  5. Drain is not centered on D1-D4 (09-18) cabinets.
  6. Slots allow for riser stack expansion and contraction.
  7. Supply and return riser stub outs are 39.75" (1100) from bottom of cabinet and is not centered vertically in slot. Drain Run-out is 3.12" (79) from bottom of cabinet.
  8. From floor to floor on one riser stack you can only have; all same style, styles 2 and 5; or styles 3 and 4. For leader/follower units you can only have styles 3 or 4 adjacent to 2 or 5.
  9. Secure riser stack to building structure.
  10. Riser should not touch cabinet and shutoff should be inside cabinet.

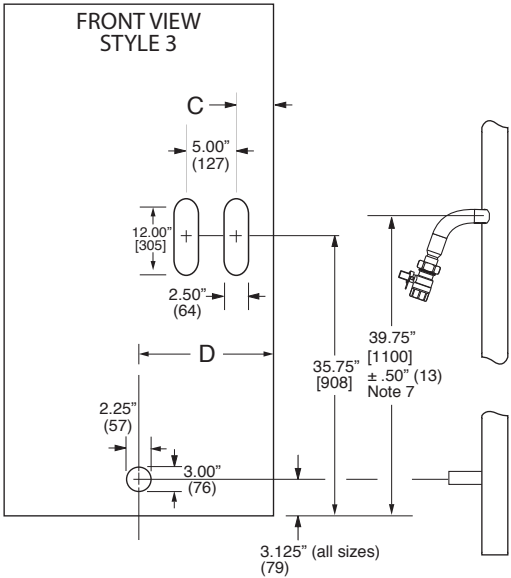

Size	A	B	C	D	E	F	G
09-12	17.00 [432]	17.00 [432]	2.75 [70]	11.93 [303]	9.18 [233]	1.71 [44]	11.34 [288]
15-18	19.25 [489]	19.00 [483]	2.75 [70]	11.93 [303]	9.18 [233]	2.83 [72]	12.08 [307]
24-36	24.25 [616]	24.00 [610]	2.73 [69]	11.98 [304]	9.25 [235]	2.83 [72]	12.08 [307]

ClimateMaster works continually to improve its products. As a result, the design and specifications of each product at the time of order may be changed without notice and may not be as described herein. Please contact ClimateMaster's Customer Service Department at 1-405-745-6000 for specific information on the current design and specifications. Statements and other information contained herein are not express warranties and do not form the basis of any bargain between the parties, but are merely ClimateMaster's opinion or commendation of its products. The latest version of this document is available at [climatemaster.com](http://climatemaster.com). © ClimateMaster, Inc. All rights reserved 2014



# E Cabinet Dimensions

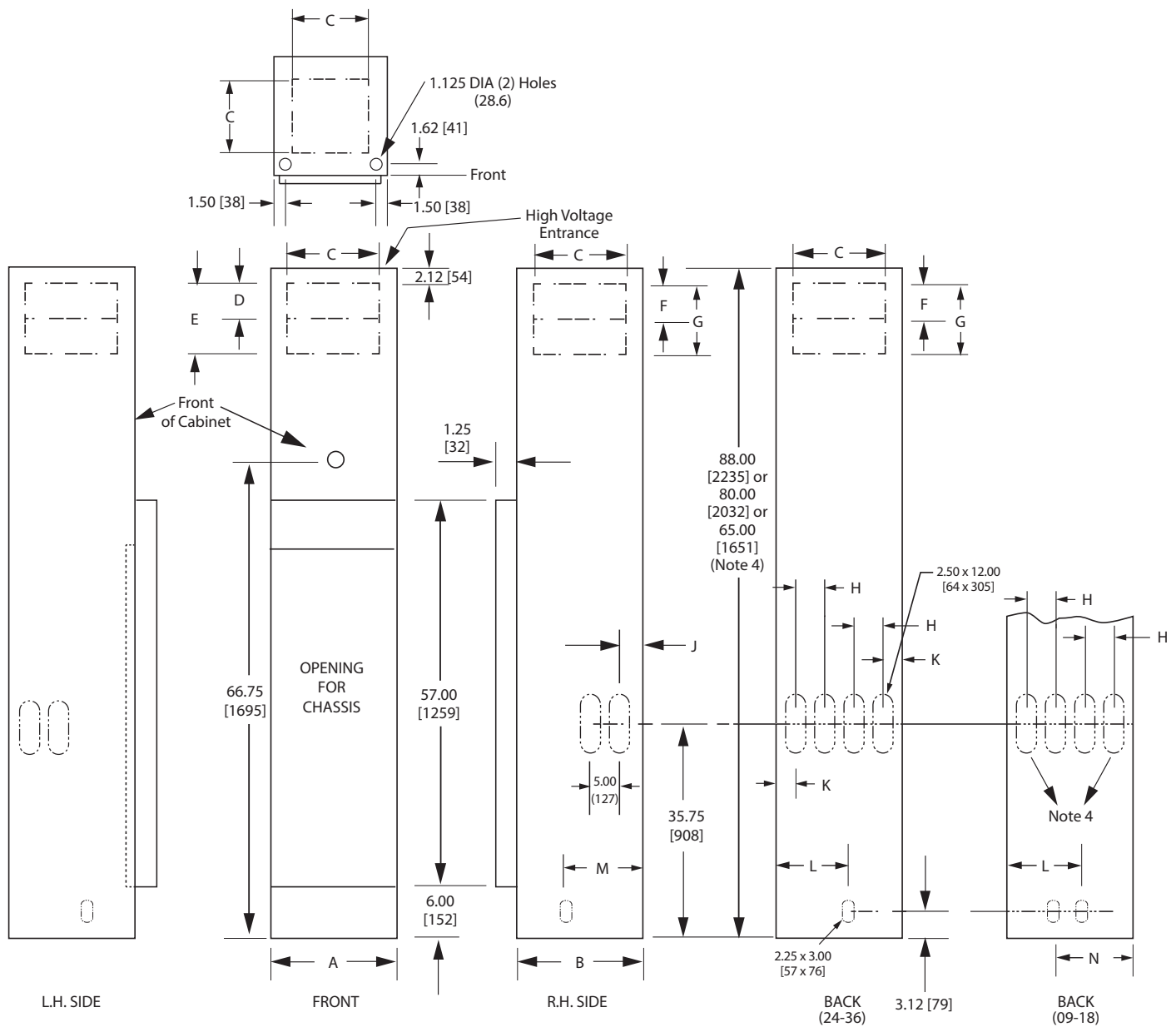

## Notes:

1. All dimensions are in inches (mm).
2. Cabinets have supply air and riser K.O.'s, all panels. Remove only K.O.'s necessary to configure cabinet. Seal any K.O.'s removed by mistake.
3. Service area to be width of cabinet plus 4" [102] and 24" [610] from finished wall.
4. For 9-18 cabinet use drain diagonally across from supply and return risers.

Size	A	B	C	D/F	E/G	H	J	K	L	M	N
09-12	17.00 [432]	20.00 [508]	12.00 [305]	6.00 [152]	12.00 [305]	4.63 [117]	2.75 [70]	2.09 [53]	11.34 [288]	11.93 [303]	11.34 [288]
15-18	19.25 [489]	22.00 [559]	14.00 [356]	6.00 [152]	14.00 [356]	4.63 [117]	2.75 [70]	2.84 [72]	12.09 [307]	11.93 [303]	12.09 [307]
24-36	24.25 [616]	27.00 [686]	16.00 [406]	8.00 [203]	16.00 [406]	5.00 [127]	4.23 [108]	2.83 [72]	12.08 [307]	13.48 [342]	N/A

# E Cabinet Slot Dimensions and Riser Arrangements

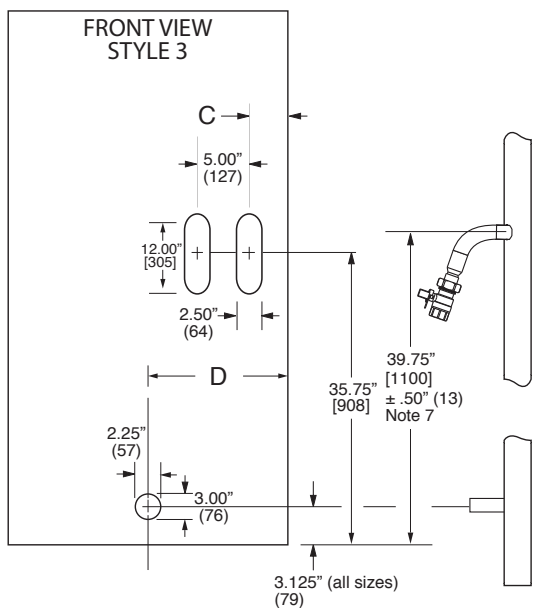
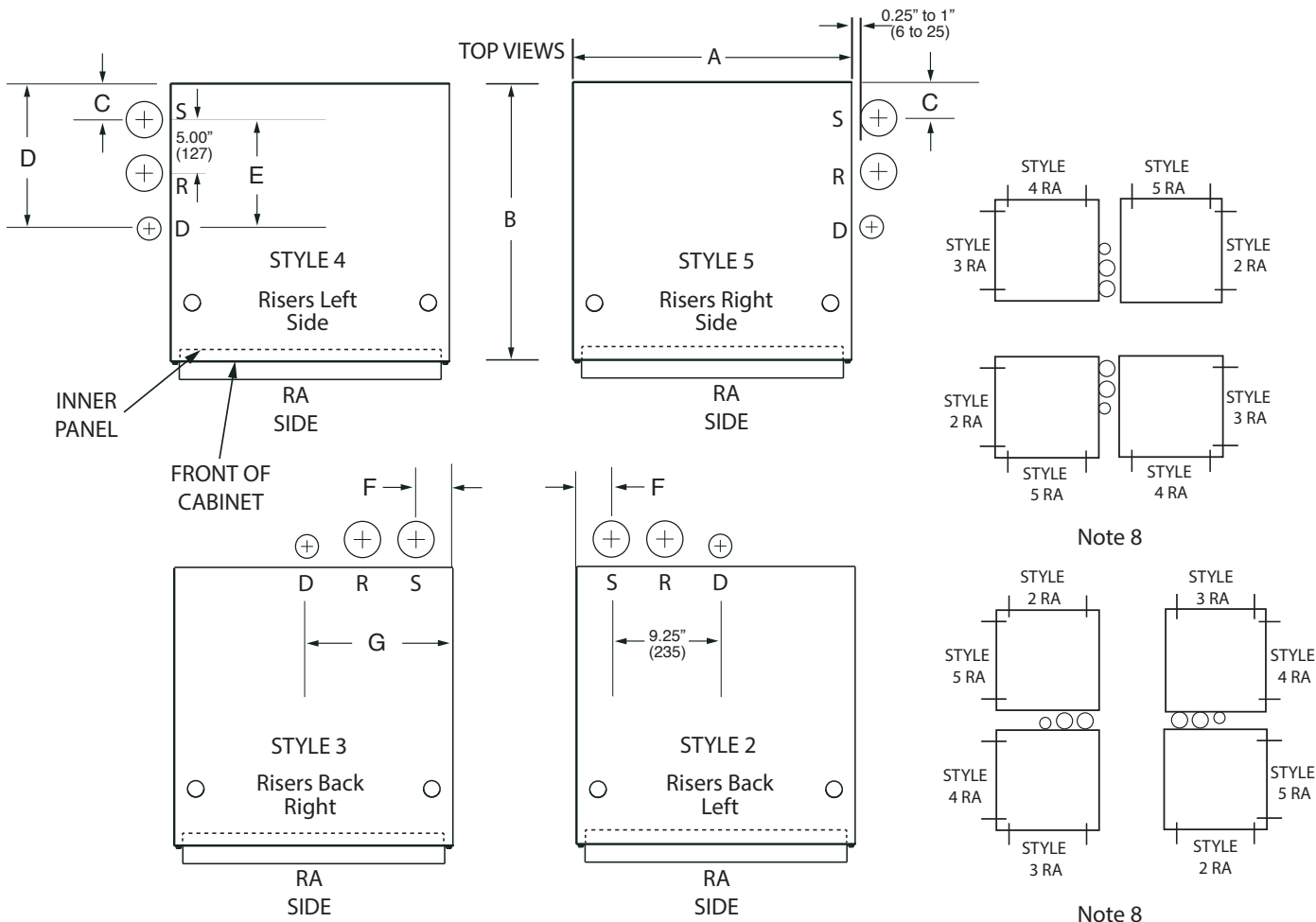

**NOTICE!** Not all styles will stack above or adjacent to each other. (See Note 8).

**Notes:**

1. Dimensions are inches [mm].
2. Style refers to cabinet model digit 9 - riser location.
3. **Return air side is the front of the cabinet.**
4. Supply riser is closest to corner.
5. Drain is not centered on all cabinet sizes.
6. Slots allow for riser stack expansion and contraction.
7. Supply and return riser stub outs are 39.75" (1100) from bottom of cabinet and is not centered vertically in slot. Drain Run-out is 3.12" (79) from bottom of cabinet.
8. From floor to floor on one riser stack you can only have; all same style, styles 2 and 5; or styles 3 and 4. For leader/follower units you can only have styles 3 or 4 adjacent to 2 or 5.
9. Secure riser stack to building structure.
10. Riser should not touch cabinet and shutoff should be inside cabinet.

Size	A	B	C	D	E	F	G
09-12	17.00 [432]	20.00 [508]	2.75 [70]	11.93 [303]	9.18 [233]	2.09 [53]	11.34 [288]
15-18	19.25 [489]	22.00 [559]	2.75 [70]	11.93 [303]	9.18 [233]	2.84 [72]	12.09 [307]
24-36	24.25 [616]	27.00 [686]	4.23 [108]	13.48 [342]	9.25 [235]	2.83 [72]	12.08 (307)

ClimateMaster works continually to improve its products. As a result, the design and specifications of each product at the time of order may be changed without notice and may not be as described herein. Please contact ClimateMaster's Customer Service Department at 1-405-745-6000 for specific information on the current design and specifications. Statements and other information contained herein are not express warranties and do not form the basis of any bargain between the parties, but are merely ClimateMaster's opinion or commendation of its products. The latest version of this document is available at [climatemaster.com](http://climatemaster.com). © ClimateMaster, Inc. All rights reserved 2014

# Typical Cabinet with "G" Panel Installation

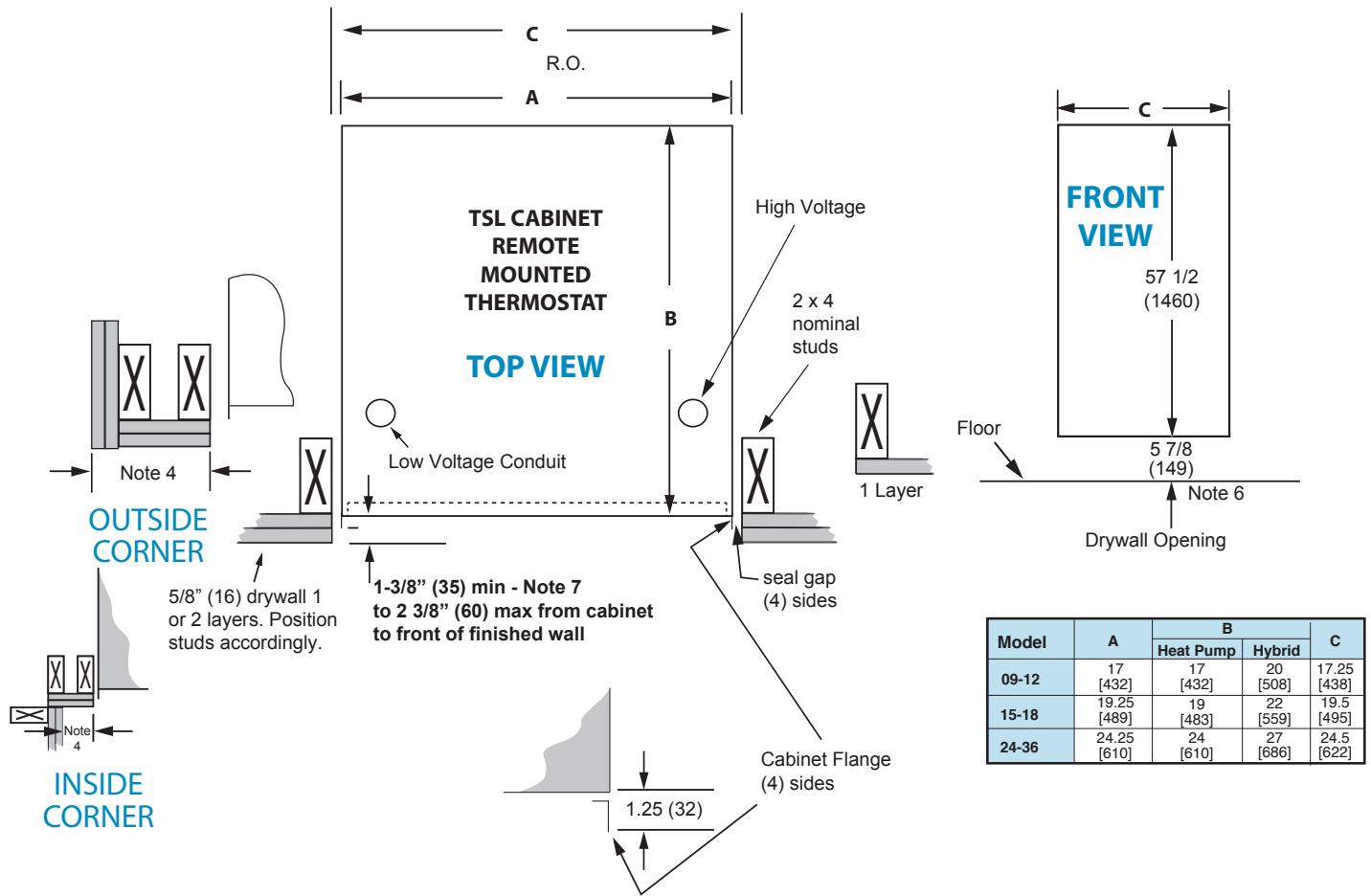

**NOTICE!**

Seal between studs and cabinet flanges with weather tight foam material to prevent wall cavity air from infiltrating unit or room.

1. All dimensions are in inches (mm).
2. Cabinet configuration will determine slab core drilling location and walls surrounding cabinet.
3. Recommend stud walls surrounding cabinet. Drywall and studs should not be attached or contacting cabinet for best sound attenuation. Where possible fill gaps with sound absorbing material. Use iso pad under cabinet. Secure cabinet to floor in two places at back.
4. Return air panel (not shown) overlaps rough opening, allow minimum of 3 1/2" (89) dry wall to corner. Do not caulk G panel to wall.
5. Installer supplied top duct should connect with flex boot.
6. If cabinet stand or ISO pad is used add to dimension.
7. For 2"(50) filter set cabinet 2"(50) minimum from front of drywall.

# Typical Recessed Cabinet with "G" Panel and Frame Installation

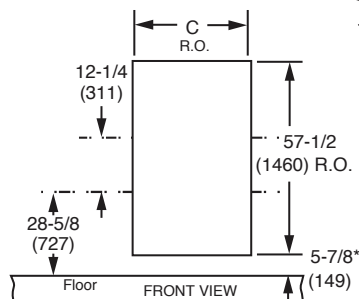
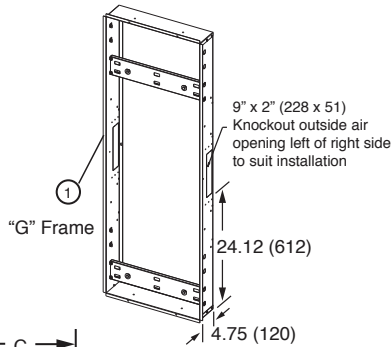
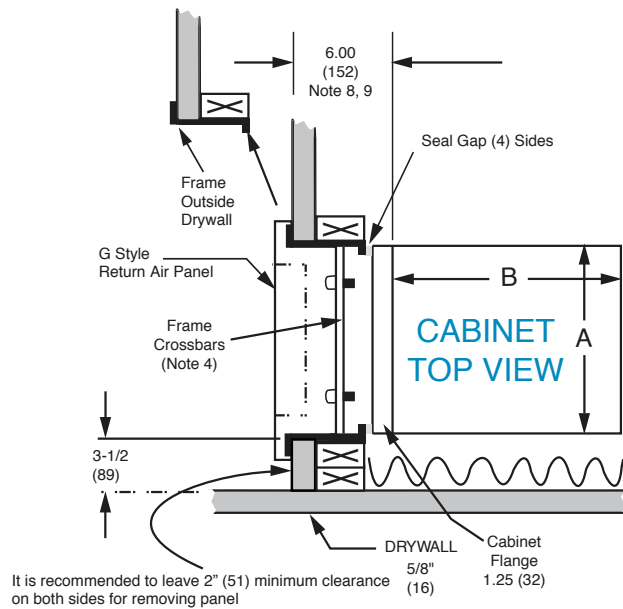

\* Dimension if cabinet is on floor.  
Add if cabinet is on stand/pad.

Kit	Size	Frame Kit			Panel
		A	B	C	D
48A0100N50	09-12	17.00 (432)	17.00 (432)	16-5/8 (400)	18.50 (470)
48A0100N51	15-18	19.25 (489)	19 (483)	19-5/8 (498)	21.50 (546)
48A0100N52	24-36	24.25 (616)	24 (610)	24-3/8 (620)	25.50 (648)

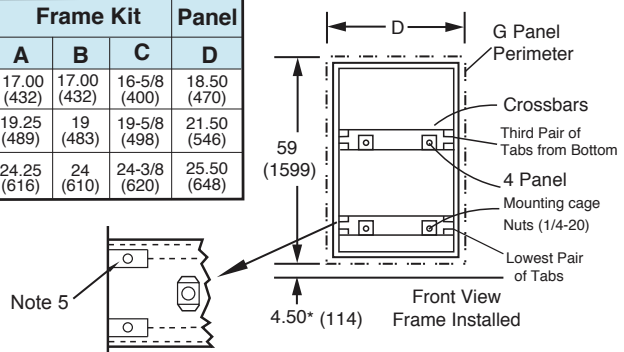

## NOTICE!

Recessed cabinet requires a frame kit.

Outside air applications require a Motorized Damper or pre-treated air that is above 45°F degrees (7°C) and below 95°F degrees dry bulb/75°F degrees wet bulb.

Attach the frame to the wall studs, not the cabinet. Use weather seal material between the frame and cabinet to avoid bypass air being pulled in from the wall cavity.

Do not distort frame. Shim the sides, if required.

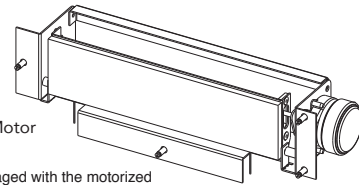

Optional Damper Motor

(Order separately)  
Refer to the IOM packaged with the motorized damper assembly for installation instructions and note 7 (below) for its usage.

Kit Part	Qty	Description
1	1	Frame
2	2	Cross Bar

### Notes:

- The cabinet configuration will determine the slab core drilling location and the wall surrounding the cabinet.
- Stud walls surrounding the cabinet are recommended. For better sound attenuation, the drywall studs should not be attached to or contacting the cabinet.
- The "G" style return air panel overlaps its rough opening. Allow a minimum of 3.5" (89) of drywall to a corner. Do not caulk the return air panel to the wall.
- The "G" panel attaches to the cross bars of the frame kit. The cabinet must be recessed behind the wall.
- For air filter access, pivot the hinged inner panel and open the snapped filter access panel.
- For chassis access,
  - Remove the entire G-Panel
  - Remove the (2x) cross bars of the frame kit
  - Remove the cabinet's filter panel
  - Slide out the chassis
- When untreated outside air will be utilized, the 48A0100N04 motorized damper must be used. The mixed air temperature must be no lower than 45°F degrees (7°C), must be no higher than 95°F DB/75°F WB, and must not exceed 20% of the cabinets total CFM output.
- For a 2" filter, set the cabinet 6.25" (158) from the front of the dry wall.
- If the drywall flanges (Qty. 4) are removed, the cabinet can be set 1" (25) closer to the finished drywall.
- All dimensions are inches (mm) with all nominal 2" x 4" studs being 1.5" (38) x 3.5" (89).

ClimateMaster works continually to improve its products. As a result, the design and specifications of each product at the time of order may be changed without notice and may not be as described herein. Please contact ClimateMaster's Customer Service Department at 1-405-745-6000 for specific information on the current design and specifications. Statements and other information contained herein do not express warranties and do not form the basis of any bargain between the parties, but are merely ClimateMaster's opinion or commendation of its products. The latest version of this document is available at [climatemaster.com](http://climatemaster.com). © ClimateMaster, Inc. All rights reserved 2014

# Hinged "G" Style Return Air Panel – AVHSG Series

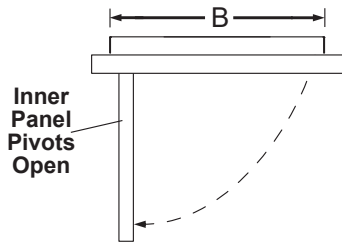

**⚠ NOTICE! ⚠**  
G Panel must be removed for chassis access

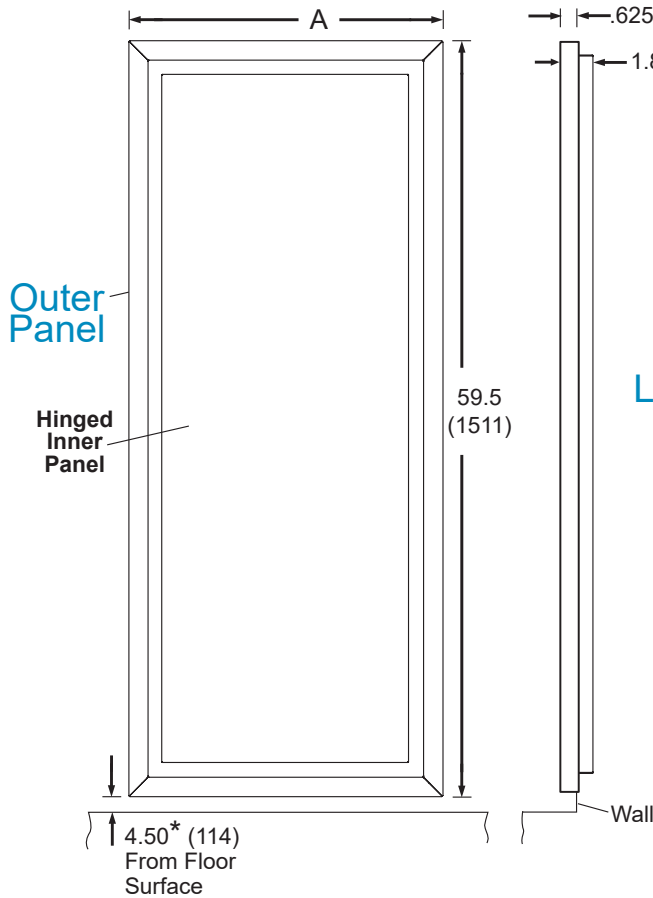

\* - Dimension increases if cabinet is on stand or pad

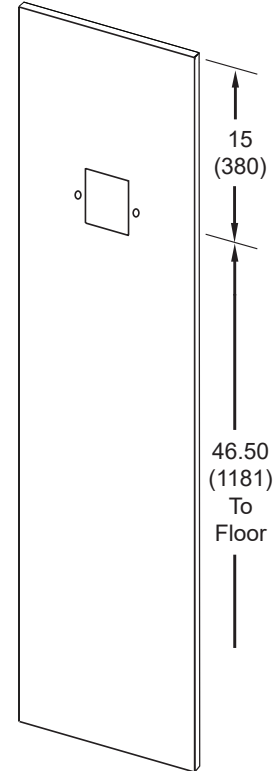
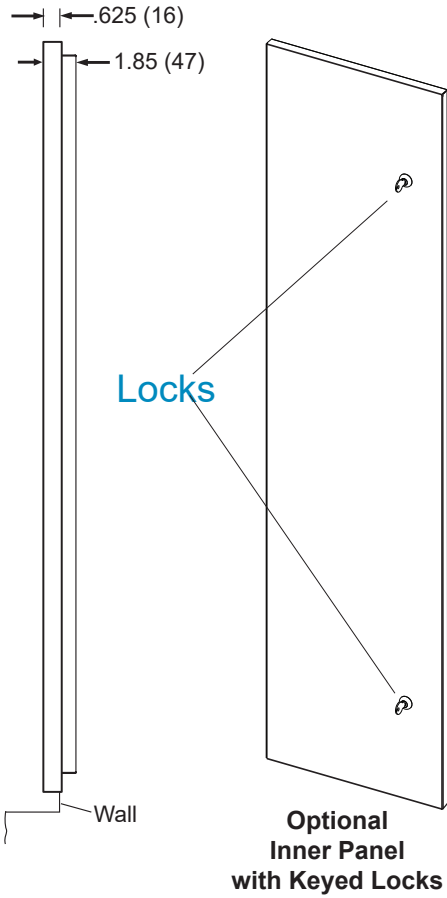

**Optional Inner Panel with Keyed Locks**

**Optional Inner Panel with holes to mount ADA thermostat**

Unit	AVHSG Digit 6	A	B
09- 12	1	19.3 [490]	16.4 [417]
15- 18	2	21.6 [549]	18.7 [475]
24 - 36	3	26.5 [673]	23.7 [602]

THERMOSTAT MOUNTING	
TYPE 1	TYPE 2
ATP21W02	AVB32V02C
ATA11U03	ATA32V01
AWC99U01	
ATA11U01	
ABV32V03C	

**Notes:**

1. Dimensions are in inches (mm).
2. Panel painted polar ice or bright white.
3. Inner panel pivots open 90°, for filter replacement without removing panel.
4. Shipped as left-hand pivot, but can be field converted to right hand. Cannot convert panel with grille or ADA options.
5. Optional locks and/or ADA mounted thermostats available.
6. Optional frame for recessed cabinet applications and damper assembly available. See Recessed Cabinet.
7. Please review the ADA knockout Type 1 and 2 thermostat table to ensure compatibility between the panel and thermostat selected.

ClimateMaster works continually to improve its products. As a result, the design and specifications of each product at the time of order may be changed without notice and may not be as described herein. Please contact ClimateMaster's Customer Service Department at 1-405-745-6000 for specific information on the current design and specifications. Statements and other information contained herein are not express warranties and do not form the basis of any bargain between the parties, but are merely ClimateMaster's opinion or commendation of its products. The latest version of this document is available at [climatemaster.com](http://climatemaster.com). © ClimateMaster, Inc. All rights reserved 2014

# "L" Style (Flush Mounting) Return Air Panel – AVHRL Series



Frame is attached to studs. Panel is removable for chassis access.

Unit	AVHRL Digit 6	D	E	F	G
09, 12	1	22.1	2.0	19.5	55.8
15, 18	2	24.1	2.0	21.5	55.8
24	3	29.6	2.0	26.5	55.9
30, 36	4	29.6	2.0	26.5	55.9

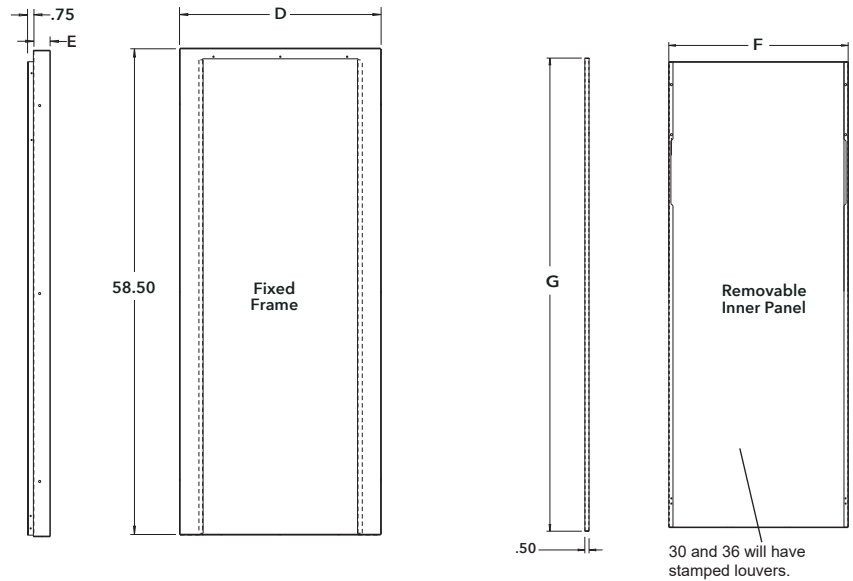

## Frame Installation

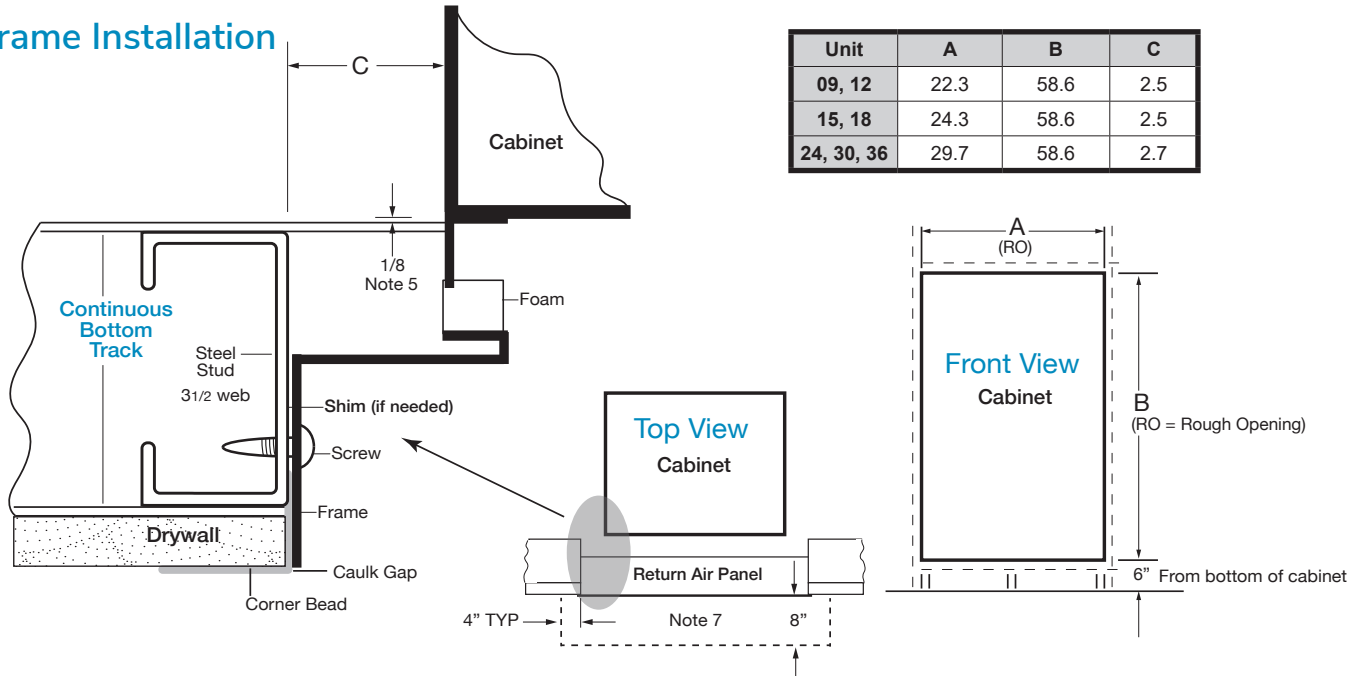

Unit	A	B	C
09, 12	22.3	58.6	2.5
15, 18	24.3	58.6	2.5
24, 30, 36	29.7	58.6	2.7

### Notes:

1. Dimensions are in inches.
2. Frame and panel painted bright white.
3. Panel is removable for filter replacement or chassis removal.
4. Frame ships with cabinet—must be installed while framing.
5. Set bottom track 1/8" in front of cabinet.
6. Drywall mud is added to the corner bead to produce a smooth finished surface.
7. Unobstructed area for required air flow.

# Hose Kits and Stands

## AHU Series Hose Kit Specifications:

- AHU hose kits used for connection with ClimateMaster standard ball valves.
- Designed for vertical high rise water-source heat pump applications.
- Kevlar® reinforced EPDM core with ANSI 302/304 stainless steel outer braid.
- Fire rated materials per ASTM E 84-00 (NFPA 255, ANSI/UL 723 & UBC 8-1).
- Swivel connection provides union between chassis and riser shutoff.
- Brass fittings, stainless steel ferrules.
- Temperature range of 15°F [9°C] to 180°F [82°C]. (Operation below 32°F requires antifreeze)
- Max. working pressure of 400 psi [2756 kPa].
- Min. burst pressure of four times working pressure.

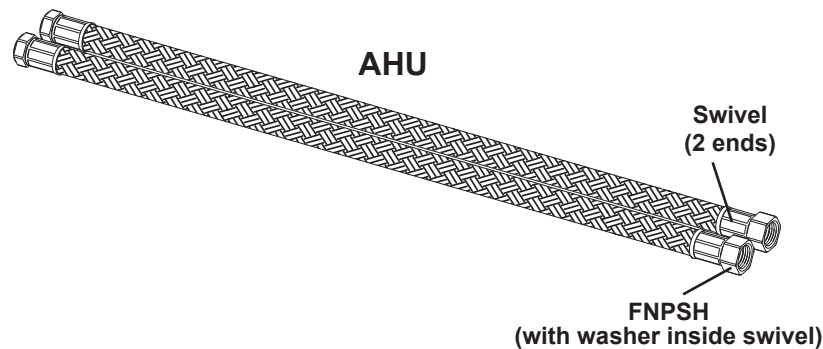

## Physical Data

Unit	Inside Diameter inches	Length feet [cm]	Working Pressure psi [kPa]	Min. Burst Pressure psi [kPa]	Min. Bend Radius inches [mm]
09 - 12	0.50	3 [91]	400 [2756]	1600 [11024]	3.56 [91]
15 - 18	0.75	3 [91]	400 [2756]	1600 [11024]	3.56 [91]
24 - 36	1.00	3 [91]	400 [2756]	1600 [11024]	4.3 [109]

## ACST Cabinet Stands

### Specifications

- 1" to 13" (25 to 330) tall, 1" (25) increments
- 16 Gauge galvanized steel
- Attached to cabinet with 4 screws
- Ships in bulk for field installation.
- Optional ISO pad 0.1" (2.5) thick

Unit	A	B	C
09-12	16.8 [427]	16.2 [411]	1 to 13 (25 to 330)
15-18	18.9 [480]	18.3 [465]	
24-36	23.9 [607]	23.3 [592]	

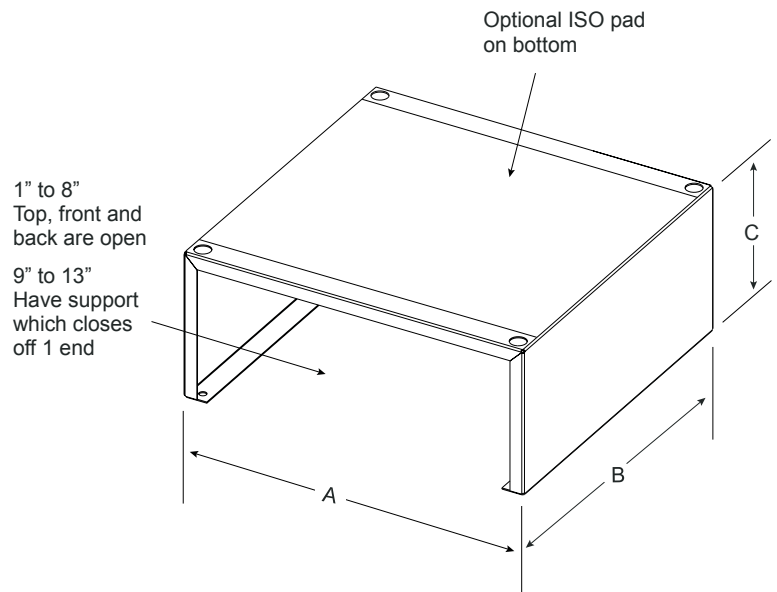



# Supply Air Openings and Grilles

## Supply Air K. O.'s in Cabinets

Cabinet Size	Cabinet Height	Front	Sides/Back	Top
C1, C2 (09, 12)	88	12 x 6 and 12 x 12		12 x 12
	80	12 x 6	12 x 6 and 12 x 12	
C3, C4 (15, 18)	88	14 x 6 and 14 x 14		14 x 14
	80	14 x 6	14 x 6 and 14 x 12	
C5, C7 (24, 36)	88	16 x 8 and 16 x 16		16 x 16
	80	16 x 6	16 x 6 and 16 x 12	

## Supply Air Grille Openings/sq. in.

Cabinet Size	Number of Openings	Minimum sq. in. Openings*	Recommended sq. in. Openings
C1, C2 (09, 12)	1 or 2	144 (1 - 12 x 12) (2 - 12 x 6)	288 (2 - 12 x 12)
C3, C4 (15, 18)	1, 2, or 3	168 (1 - 14 x 12) (2 - 14 x 6)	392 (2 - 14 x 14)
C5, C7 (24, 36)	2 or 3	384 (2 - 16 x 12)	512 (2 - 16 x 16)

Nominal Grille Size	Double Deflection Free Area (sq. ft.)		
	Deflection 0°	Deflection 22 1/2°	Deflection 45°
12 x 6	.30	.28	.22
12 x 12	.65	.59	.48
14 x 6	.40	.38	.33
14 x 12	.80	.71	.55
14 x 14	.95	.86	.70
16 x 8	.61	.55	.44
16 x 12	.93	.85	.68
16 x 16	1.25	1.12	.90

\* Less than minimum sq. in. opening will have higher sound levels than published

### Notes:

1. When selecting supply air openings/grilles consider CFM, velocity (throw), added static pressure and sound.
2. Other sizes available as special.
3. If custom grille sizes are used - area should be greater or equal to above.
4. If using more than recommended number of opening, total CFM may be reduced or be unstable (PSC or ECM Motor).
5. If only top is used, suggest using TSL which are shorter cabinets so that duct will have more space to be designed for static regain.

# Supply Air Openings and Grilles

Grilles are shipped loose for field installation after drywall has been finished. Grilles are offered in three different styles, brushed aluminum, painted polar ice or painted bright white to match the return air door standard colors. Overall dimensions - add 1.25" (32) to nominal dimensions.

## A816GA Series Grilles

**Single Deflection** - Adjustable vertical blades for controlling horizontal path of discharge air (Left/Right).

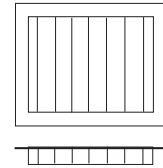

## A816GB Series Grilles

**Double Deflection** - Adjustable vertical and horizontal blades for controlling horizontal and vertical path of discharge air. (Left/Right and Up/Down)  
Recommended for all standard applications.

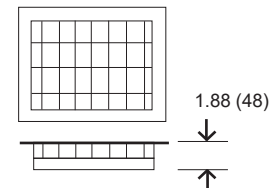

## A816GC Series Grilles

**Double Deflection with Opposed Blade Damper** - Addition of opposed blade damper to grille allows control of air volume (CFM) and path of discharge air. Recommended for applications requiring unequal air flow or side discharge grille(s) with additional top discharge air opening.

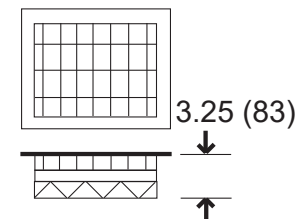

**Unequal Air Flow** - Air discharges requiring different air volumes (CFM). Use double deflection with opposed blade damper grilles.

**Top Discharge** - Units are designed to operate against relatively low air resistance (external static). Use of liberal duct sizing is recommended to maximize total unit air flow (CFM). Top duct outlet will offer more resistance to air flow than side outlets on the same cabinet. For top discharge only use TSL Series.

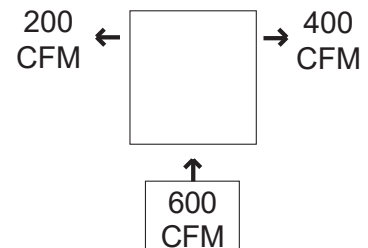

## ⚠ NOTICE! ⚠

Top air discharge units will require turning vanes and/or a volume damper for proper air flow and balancing, to minimize turbulence. These components must be field furnished and installed in accordance with SMACNA guidelines.

# Thermostats

Whether you're on a tight budget or have interest in the latest technology we have many types of thermostats to meet your project needs. Check out the details of our full thermostat product offering on the [Thermostats & Accessories](#) page of the ClimateMaster website.

Standard thermostats ship stand-a-lone and require field labor to make wiring connections on thermostats. ClimateMaster's A91558 Series adds a 6" whip factory assembled to the thermostat on one end with a 9-pin electrical quick connector on the other end. This is

designed for remote thermostat location applications. Cabinets can be order with 15', 25', or 35' remote thermostat whips. These whips come with the matching 9-pin electrical connector so thermostats can be quickly and easily installed in the field.

Customer supplied thermostats should be approved by ClimateMaster Engineering Department prior to using.

Below are a few examples of how thermostats are wired. Please see TSL and thermostat IOMs for full details.

## Typical Thermostat 24v Wiring

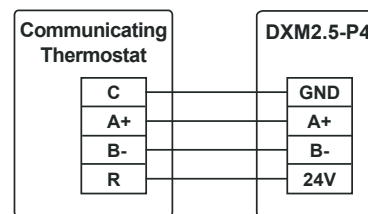
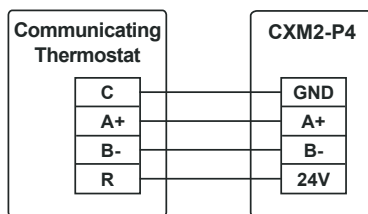
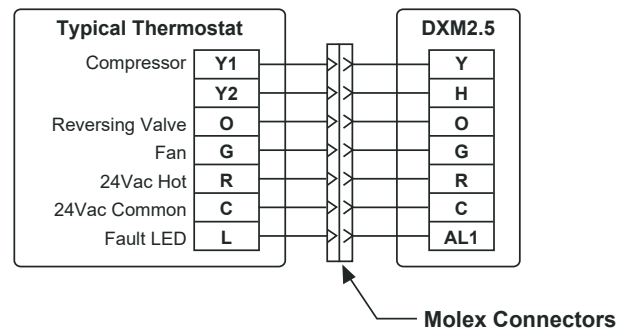
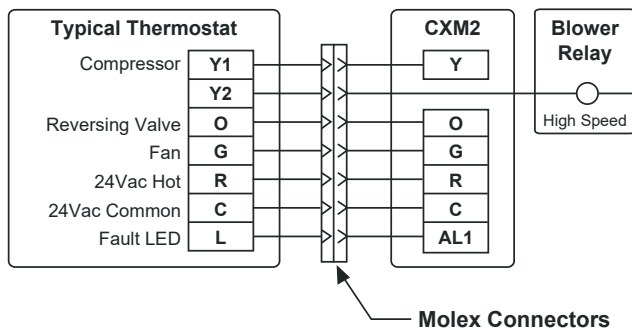

Thermostat Assembly with Molex Connector 6" Pigtail	Thermostat Only+	Remote	Surface	ADA	CXM2	DXM2.5	Manual Changeover	Automatic Changeover	Programmable	Digital	Fault Indicator	Setback Override	Fan Speeds	Wi-Fi	Wireless Remote Temp. Sensor
A9155801	ATA11U01	X	X	X	X	X	X	X	-	X	X	-	1	-	-
A9155802	ATA11U03	X	X	X	X	X	X	-	-	X	-	-	2*	-	-
A9155804	ATA22U01	X	X	X	X	X	X	X	-	X	X	-	2**	-	-
A9155809	ATP21W02	-	-	X	X	X	X	X	X	X	X	-	1	-	-
A9155810	ATP21W02	-	X	-	X	X	X	X	X	X	X	-	1	-	-
A9155811	ATP21W02	X	-	-	X	X	X	X	X	X	X	-	1	-	-
A9155805	ATP32U03C	X	X	X	X	X	X	X	X	X	X	X	2**	-	-
A9155807	AWC99U01	X	X	X	X	X	X	X	X	X	X	X	2**	X	X
A9155813	ATA32V01	X	X	X	X	X	X	X	-	X	-	X	2**	-	-
A9155814	AVB32V02C	X	X	X	X	X	X	X	X	X	X	X	2**	X	X
A9155815	AVB32V03C	X	X	X	X	X	X	X	X	X	X	X	2**	X	X

\*Fan speed change automatic through thermostat Y2 signal.  
 \*\* - Manual speed change  
 Note: A9155809 for ADA, A9155811 for Remote Mount.

# Thermostats

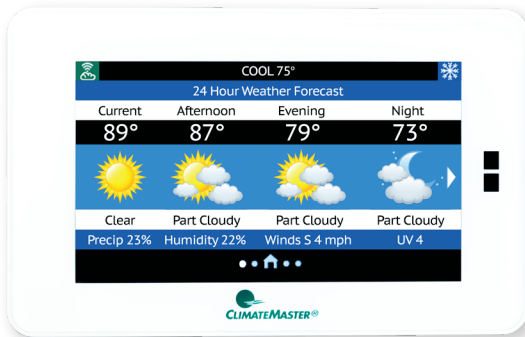

## AWC COMMUNICATING THERMOSTAT (AWC99U01)

5.1" w x 3.2" h x 0.9" d

- iGate® 2 Communicating (AWC) Thermostat
- Wi-Fi Enabled
- Remote troubleshooting and diagnosis
- Color Touch Screen
- 7-day Programmable
- Humidity control

## CM 500 (AVB32V03C)

5.25" w x 4" h x 1.1" d

- 7-day Programmable
- Wi-Fi Enabled
- Color Touch Screen
- Humidity control
- For use with water source heat pumps
- Mobile and web apps available for remote monitoring
- California Title 24 compliant

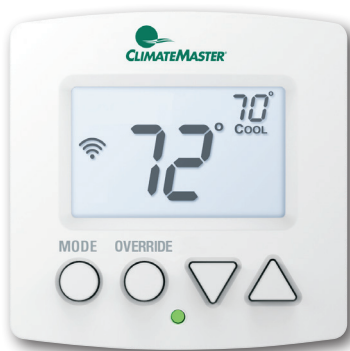

## CM 300 (AVB32V02C)

3.2" w x 3.2" h x 0.9" d

- 7-day Programmable
- Wi-Fi Enabled
- Humidity control
- For use with water source heat pumps
- Mobile and web apps available for remote monitoring
- California Title 24 compliant

## CM 100 (ATA32V01)

3.1" w x 3.1" h x 1.0" d

- Auto Changeover - Automatically switches between cooling or heating
- LED indicator light glows green or red to indicate cooling or heating
- Can control temperature to within 1° of set point
- 3-stage heating and 2-stage cooling for use with heat pump
- All programming and set points stored in nonvolatile memory
- Key pad Locking - set points can only be adjusted by authorized individuals when this feature is on
- Large number display, extremely easy to operate and program

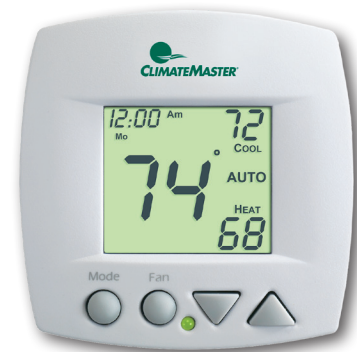

# TSL Cabinet Options

### Optional Cabinet Disconnect Switch

Located on control box access door. Can be accessed through slot in "G" Panel Frame. Classified as motor disconnect. See Cabinet decoder.

### Optional Cabinet Circuit Breaker

Located on control box access door. Can be accessed through slot in "G" Panel Frame. All 208/230V and 265V 15 and 20 amp classified as HACR breaker. 265V 25 amp and higher classified as supplemental breaker. See Cabinet decoder.

### Optional Thermostat Wire Harness (WHIP)

Low voltage wire harness 15, 25, or 35 foot ending with 9-Pin Molex quick connector. Exits cabinet on top, left front corner. Thermostat cable is rated CL-2. See Cabinet decoder. Can be encased in BX conduit as special, contact factory.

### Optional Premium Seal

Located on cabinet filter panel, seal is upgraded to extruded rubber gasket for durability and long life.

### Optional 2" Filter and Holder

2" filter improves air filtration and reduces maintenance.

### Accessory Filters (Not available for every application - check blower table for ESP)

- 1" (25 mm) thick, MERV 8, and MERV 11
- 2" (50 mm) thick, MERV 8, MERV 11, and MERV 13

### TSL Accessory Filter ESP Table

Model	Size	TSL with ECM Motor		Accessory Filter Initial ESP						
		Max CFM	Max ESP	coil area sq ft	face velocity fps	Merv 8		Merv 11		Merv 13
						1"	2"	1"	2"	2"
D1	9	450	0.4	2.5	180	0.08	0.06	0.09	0.08	0.15
D2	12	450	0.4	2.5	180	0.08	0.06	0.09	0.08	0.15
D3	15	700	0.5	2.5	280	0.17	0.14	0.22	0.15	0.25
D4	18	800	0.5	2.5	320	0.20	0.16	0.29	0.19	0.28
D5	24	950	0.6	3.4	280	0.17	0.14	0.22	0.15	0.25
D6	30	1150	0.6	3.4	340	0.22	0.16	0.33	0.20	0.30
D7	36	1350	0.6	3.4	400	0.26	0.21	0.44	0.24	0.34

ClimateMaster works continually to improve its products. As a result, the design and specifications of each product at the time of order may be changed without notice and may not be as described herein. Please contact ClimateMaster's Customer Service Department at 1-405-745-6000 for specific information on the current design and specifications. Statements and other information contained herein are not express warranties and do not form the basis of any bargain between the parties, but are merely ClimateMaster's opinion or commendation of its products. The latest version of this document is available at [climatemaster.com](http://climatemaster.com). © ClimateMaster, Inc. All rights reserved 2014

# Riser Definitions

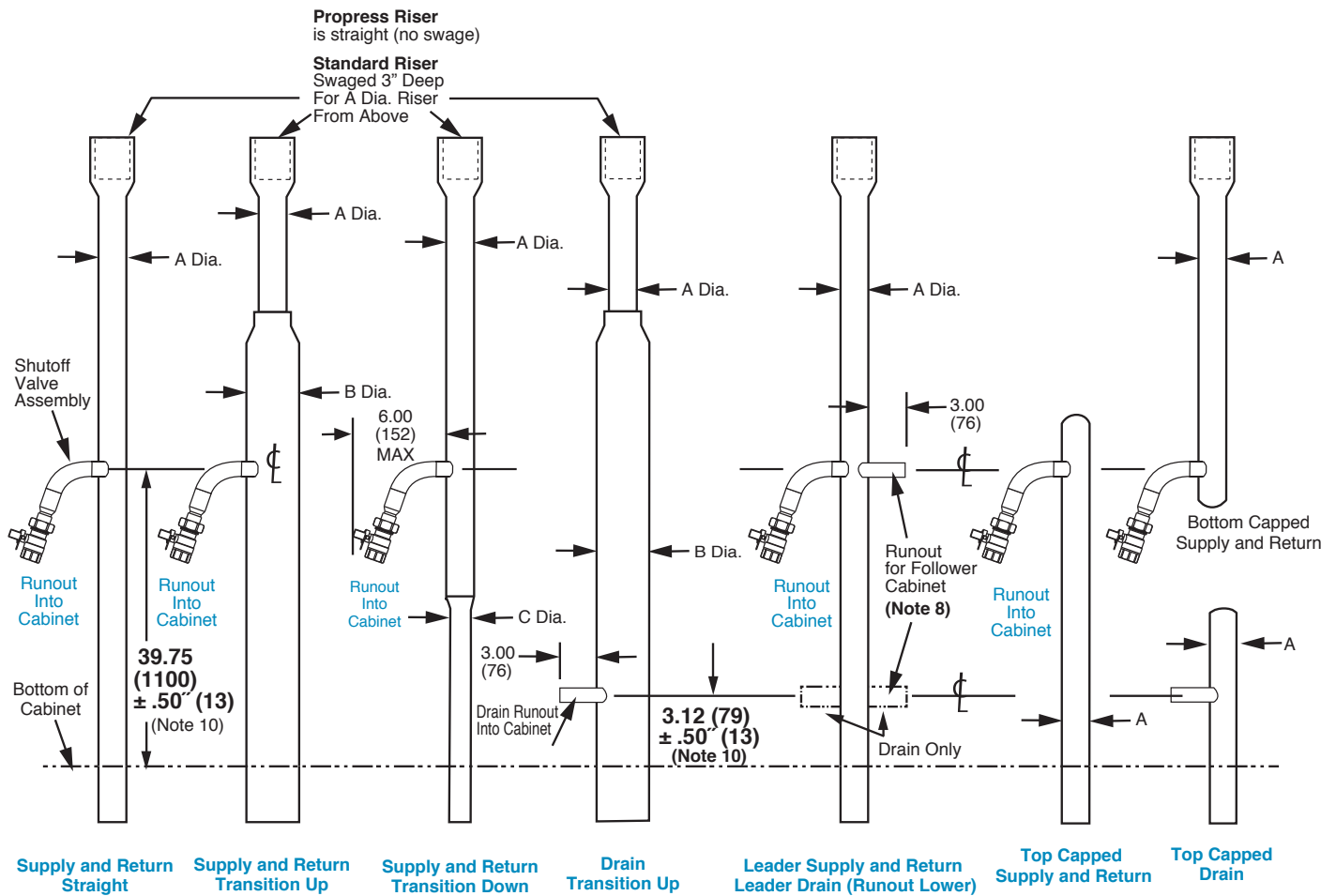

	Riser Diameter (in)						
A	1.00	1.25	1.50	2.00	2.50	3.00	4.00
B	1.25	1.50	2.00	2.50	3.00	-	-
C	-	1.00	1.25	1.50	2.00	2.50	-

## Notes:

1. You must know water flow direction to determine if cabinet requires transition up or down.
2. Transitions can only change by one diameter (1" to 1¼", 1¼" to 1½", etc.)
3. Riser transition couplings and run-outs are factory brazed.
4. All risers are factory pressure tested.
5. Standard riser diameters are nominal 1", 1¼", 1½", 2", 2½", and 3". Please consult the factory on pricing for nominal 4" water tubing.
6. Copper Type M and L available (4" L only).
7. Drain riser insulated standard. Insulation is optional for supply and return
8. Leader riser - For follower cabinet riser ball valve assemblies, 12" of straight copper are provided for field connection to the leader riser. Assembly to be cut to length and field brazed. In applications where more than 12" of straight copper is needed, copper and fittings to be field provided.
9. Standard ball valves have NPSH threads for connection to AHU hoses (1/2" for D/E1-2 (sizes 09-12); 3/4" for D/E3-4 (sizes 15-18); 1" for D/E5-7 (sizes 24-36)).
10. If cabinet stand or thick ISO pad is used, at installation add height/thickness to shutoff valve and drain run-out height. Verify riser shutoff height with plans before brazing.

**Note: ClimateMaster units with motorized valve option have water high pressure switches. Do not design riser stack where switch will not reset (trip - 300 PSI; Reset - 250 PSI).**

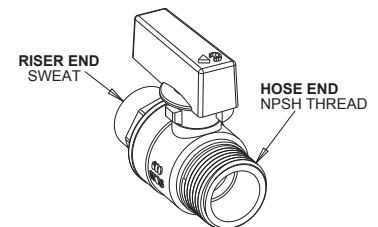

**Standard Valve**  
(Cabinet Digit 10 = 5)  
Used with AHU Style Hoses

# Riser GPM Definitions and Sizing

Riser GPM requirements and individual Unit GPM requirements are necessary to select the proper Riser Piping diameters. Refer to this page to determine GPM requirement, then refer to Riser Diameter Sizing Table to determine Riser Piping diameters.

Example is for bottom supply (upward flow) - bottom return (downward flow) system feed loop, both supply and return will be same GPM. GPM's are dependent upon unit load and system loop water temperatures. Please refer to Performance Charts for individual Unit GPM requirements.

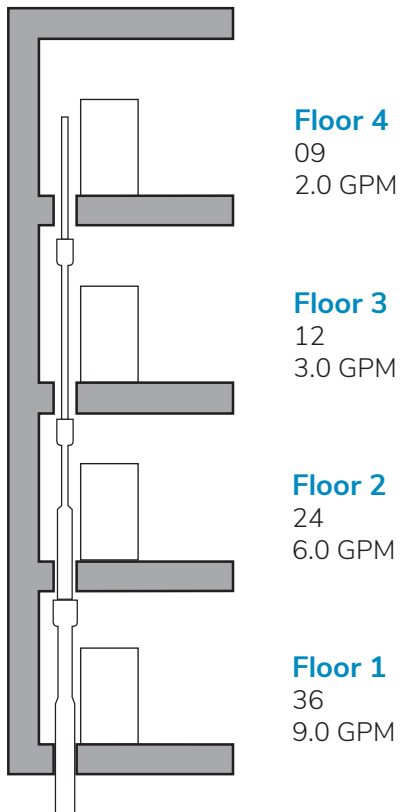

**Unit GPM (UGPM)** = Required gallons per minute from "Performance Charts," or GPM used to calculate unit capacity.

**Note:** For factory installed AFR check Flow Rate available (See Table)

**Total Riser GPM (TRGPM)** = The total GPM's required for all units on each riser.

**Total GPM Per Floor (TGF)** = Total GPM minus the sum of Unit GPM from all floors above or below, depending on direction of flow.

**Example:** Four floors, Consisting of units sizes TSL36, TSL24, TSL12 and TSL09, as shown in diagram. UGPM's are 9.0, 6.0, 3.0 and 2.0 respectively.

$$\text{TRGPM} = 9.0 + 6.0 + 3.0 + 2.0 = 20 \text{ GPM.}$$

## Upward Flow:

- Floor 1: TGF = 20 Add all floor GPM's (TRGPM).
- Floor 2: TGF = 11 Total GPM minus floor 1 GPM.
- Floor 3: TGF = 5 Total GPM minus floors 1 and 2 GPM's.
- Floor 4: TGF = 2 Total GPM minus floors 1, 2, and 3 GPM's.

## Downward Flow:

- Floor 4: TGF = 20 Add all floor GPM's (TRGPM).
- Floor 3: TGF = 18 Total GPM minus floor 4 GPM.
- Floor 2: TGF = 15 Total GPM minus floors 1 and 2 GPM's.
- Floor 1: TGF = 9 Total GPM minus floors 1, 2, and 3 GPM's.

Auto-Flow Regulator (US GPM) Code							
	5/8 Sweat		7/8 SWEAT				
	Unit 09	Unit 12	Unit 15	Unit 18	Unit 24	Unit 30	Unit 36
<b>C</b>	1.5	-	-	-	-	-	-
<b>D</b>	2.0	2.0	-	-	-	-	-
<b>E</b>	2.5	2.5	2.5	-	-	-	-
<b>F</b>	3.0	3.0	3.0	3.0	-	-	-
<b>G</b>	-	3.5	3.5	3.5	-	-	-
<b>H</b>	-	-	4.0	4.0	4.0	-	-
<b>J</b>	-	-	-	5.0	5.0	5.0	-
<b>K</b>	-	-	-	-	6.0	6.0	6.0
<b>L</b>	-	-	-	-	7.0	7.0	7.0
<b>M</b>	-	-	-	-	-	8.0	8.0
<b>N</b>	-	-	-	-	-	-	9.0
<b>P</b>	-	-	-	-	-	-	10.5

# Riser Diameter Sizing

Refer to Riser GPM Definitions and Sizing for the prefix to this example.

Each TSL Vertical Stack unit has three riser pipes: supply, return, and drain. The following example will be for Supply and Return riser pipe (from the top floor to the bottom floor), supply flow up and return flow down.

**Note:** If flows are both same direction, you will have to create two table 3's, Supply and Return

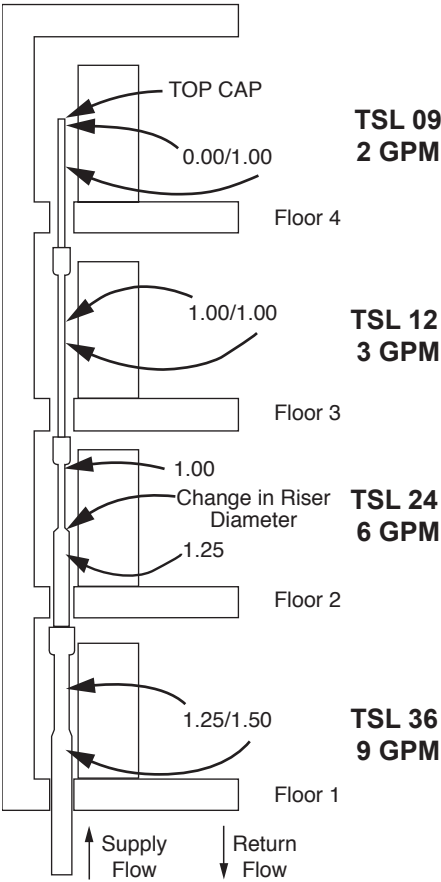

From Table 1 (below) determine the proper riser diameter needed to satisfy the required GPM's at each unit. Refer to Table 2 (below) for a summary.

**Top Cap** - Top half of riser is eliminated and sealed.  
**Bottom Cap** - Bottom half of riser is eliminated and sealed.

The following nomenclature is used to designate the diameters at the top (always first) and bottom of each unit.

- 0.00/1.00** - Indicates top cap/1" bottom.
  - 1.00/1.00** - Indicates 1" top/bottom.
  - 1.00/1.25** - Indicates 1" top/1.25" bottom.
  - 1.25/1.50** - Indicates 1.25" top/1.50" bottom.
- (from this we develop Table 3)

**Note:** Transition risers limited to 1 nominal diameter size larger or smaller within each floor (cabinet).

**Table 1**

Maximum GPM	10	16	23	48	80	135	190
Nominal Riser Diameter	1"	1-1/4"	1-1/2"	2"	2-1/2"	3"	4"

Max GPM for 1" to 1½" sized for 4 FT per second velocity  
 Max GPM for 2" to 4" sized for 5.5 FT per second velocity

**Note:** Max GPM per NABB recommendation. Never exceed 6.5 FPS, excessive noise and abrasion will occur.

**Table 2**

Floor	TGF	Diameter From Table 1
4	2	1" [25.4]
3	5	1" [25.4]
2	11	1.25" [31.8]
1	20	1.50" [38.1]

**Table 3**

Nomenclature per Unit	Description
0.00/1.00	Top Cap, w/1" Bot Feed
1.00/1.00	1" Full Length Riser
1.00/1.25	1" Top, 1.25" to 1st Floor
1.25/1.50	1.25" Top, 1.50" Bottom

**Table 4 (From IMC-2012 Table 307.2.2)**

Drain Diameter	Max Tonnage
1" [25 mm]	40
1¼" [32 mm]	90
1½" [38 mm]	125
2" [51 mm]	250

Values from Table 3 are to be entered on the Riser Piping Schedule of EZ order. Top diameter must match bottom diameter of floor above.

To calculate drain riser diameter, add up unit tonnage and use Table 4. Example has 6¾ tons, so 1" diameter is adequate.

ClimateMaster works continually to improve its products. As a result, the design and specifications of each product at the time of order may be changed without notice and may not be as described herein. Please contact ClimateMaster's Customer Service Department at 1-405-745-6000 for specific information on the current design and specifications. Statements and other information contained herein are not express warranties and do not form the basis of any bargain between the parties, but are merely ClimateMaster's opinion or commendation of its products. The latest version of this document is available at [climatemaster.com](http://climatemaster.com). © ClimateMaster, Inc. All rights reserved 2014



# Swage Riser Length Definitions and Sizing

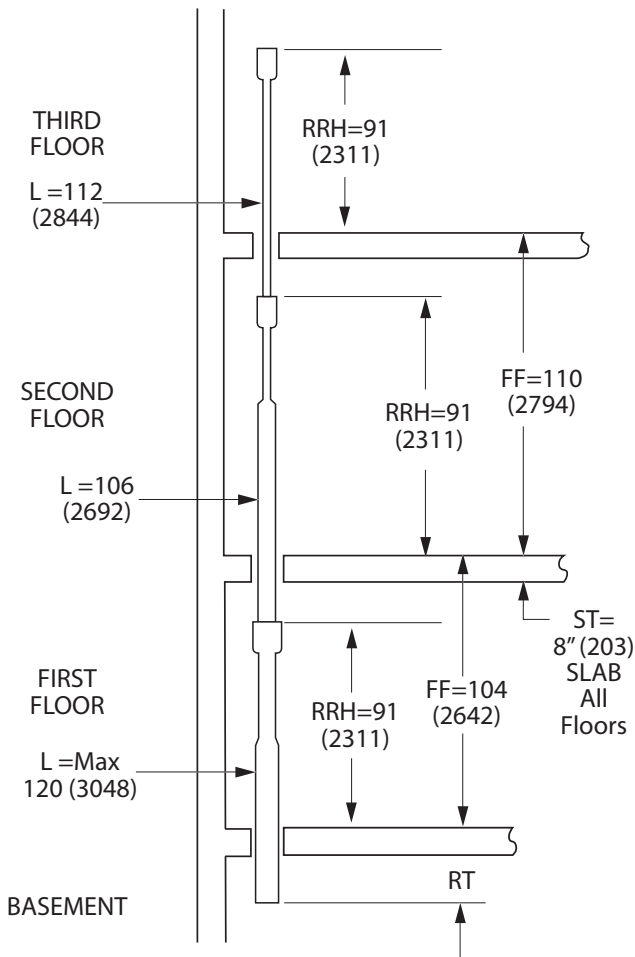

**Total Riser Length (L) for same height cabinets on every floor** = FF of floor below + 2" (51)

**Note:** If cabinet heights are mixed then L must be calculated.

**Floor To Floor Height (FF):** Distance from top of slab to top of above slab.

**Room Riser Height (RRH):** = 91 (2311) for all TSL's.

**Riser Tail (RT):** Length of riser extending down from the cabinet. Riser tail piece must extend a minimum of 5" (127) below slab.  $RT = L - RRH$

**Slab thickness (ST):** Slab thickness plus and additional material added to slab prior to setting cabinets.

**Riser insertion into swage** = 2" (51)

## Calculating Riser Dimensions for Example: 8" finished slab all floors

**FIRST FLOOR - (Pick L depending how far below slab wanted)**

$$L = 120 (3048) \text{ Max Standard Length}$$

$$RT = L - RRH = 120 (3048) - 91 (2311) = 29 (737)$$

**SECOND FLOOR**

$$L = FF (\text{Floor 1}) + 2 (51) = 106 (2692)$$

$$RT = L - RRH = 106 (2692) - 91 (2311) = 15 (381)$$

**THIRD FLOOR**

$$L = FF (\text{Floor 2}) + 2 (51) = 112 (2844)$$

$$RT = L - RRH = 112 (2844) - 91 (2311) = 21 (533)$$

## Notes:

- For calculating riser length do not include ISO pad or stand, except remember that below (B) on any floor should be 5 (127) or more for ease of brazing. For risers installed before cabinet—ISO pad or stand does affect riser shutoff valve and drain stub setting dimension from floor, add to 39.75 (1100) and 3.12 (79). Check plans before brazing.
- If riser maximum is exceeded or RT is less than slab + 5" (127) must use extension, see riser extension sizing.
- Complete all core drilling before assembling riser stack.
- Set from lowest floor up.
- Risers ship in bulk. Can ship by floor as special.
- Secure riser stack to building structure and use expansion fittings as required.
- For calculating and entering on EZ, use full length even if top or bottom is capped.
- Dimensions are inches (mm).

# Swage Riser Extension Definitions and Sizing

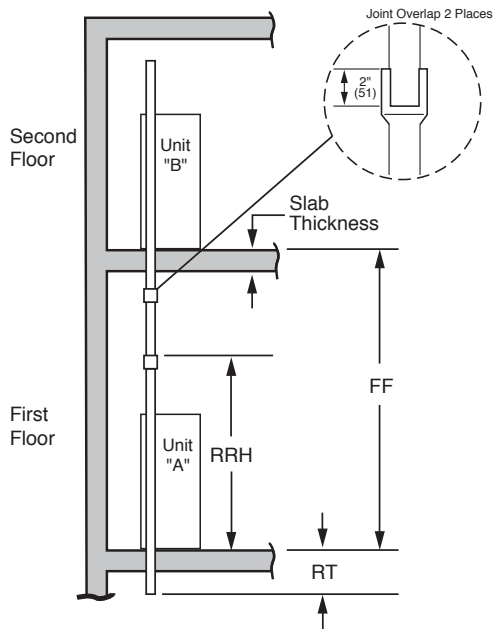

**Riser Extension Length:** Start with the floor to floor Dim. (FF) From this subtract the room riser height and tail length. Then add 4" (102) for the two joint overlaps.

**Riser Extension Length** = FF {First floor} - (RRH {First floor} + RT {Second floor}) + 4" (102). Minimum extension is 10 (254). Reduce riser length, if needed.

**Riser Tail (RT):** Length of riser extending down from the cabinet. Riser tail must extend a minimum of 5" (127) below slab, for ease of brazing.

**Room Riser Height (RRH):** 91 (2311) for TSL.

**Floor To Floor Height (FF):** Distance from top of slab to top of above slab. Slab thickness (ST); Slab thickness plus and additional material added to slab prior to setting cabinets.

**Special care must be taken in sizing riser lengths and tail piece lengths when:**

- A) Riser extensions are used.
- B) Floor to floor heights vary.
- C) Slab thickness varies from floor to floor.

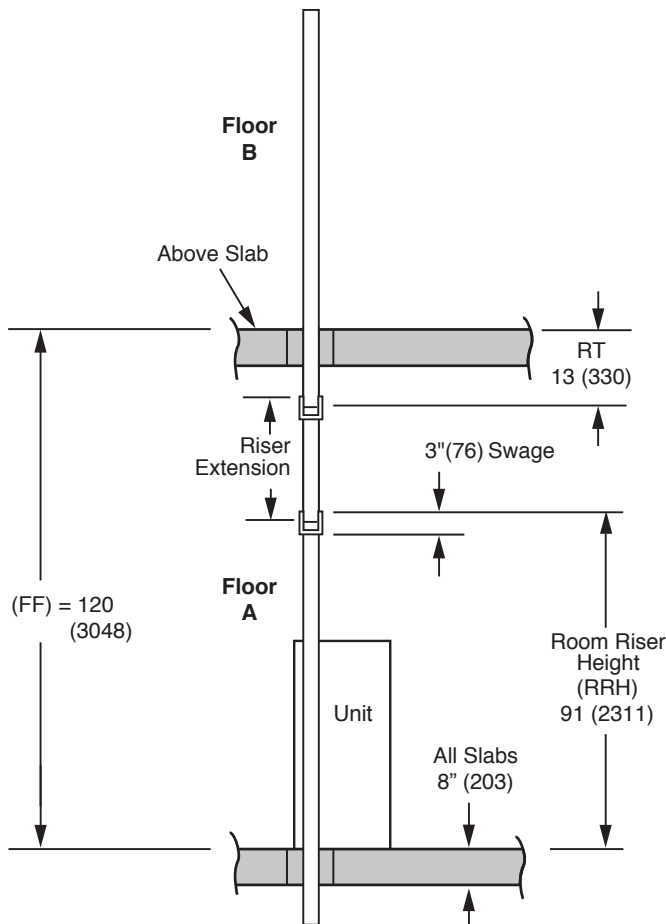

Calculate extension length for Floor A.

**Example:** Floor to floor (FF) = 120" (3048)  
 Room Riser Height (RRH) = 91" (2311)  
 RT (Floor above) = 13" (330).

**Riser Extension:**  $120" - (13" + 91") + 4" = 20"$   
 $3048 - (330 + 2311) + 102 = 508 \text{ mm}$ .

**Notes:**

1. Example shown - riser extensions would be ordered with Floor "A" and assembled between "A" and "B".
2. Riser and extension "A" Top and Riser "B" bottom must be the same diameter. Extensions cannot transition.
3. Extensions are shipped loose, bulk shipped to minimize shipping cost.
4. Dimensions are inches (mm).
5. Any extension below "A" can be ordered as a factory special.

# Slab Hole Chart – 3 Pipe

## Riser Stack Patterns



or



Clear Height is Floor to Ceiling Dimension

## Slab Hole, Risers Ship Loose and Installed Before Cabinet

Model	Clear Height		Riser Length		Riser Diameter					
					3	76.2	2	50.8	1	25.4
	in	mm	in	mm	in	mm	in	mm	in	mm
All	105	2667	115	2921	6 1/2	165	5 1/2	140	4 1/2	114
	100	2540	110	2794						
	96	2438	106	2692						
	95	2413	105	2667						
	94	2387	104	2641						
	93	2362	103	2616						

Dimensions for 8" (203) slab

Clear height is dimension from floor to ceiling. Riser length is clear height plus slab thickness plus 2" (50).

Opening centerline must be aligned from floor to floor

For risers over 100" (2540) using extensions with clear height equal to riser length or more, the hole size can be riser diameter plus 1" (25 mm).

If riser diameter is not shown use next larger size.

Contractor is responsible to meet all codes and regulations.

# Shipping

## Units Are Shipped FOB Factory

### Chassis can be shipped in two ways,

1. Standing upright, chassis are packaged in a shipping carton and are shipped four chassis per pallet (See Figure 1).
2. Standing upright, chassis are shipped in the cabinet. The chassis cabinet combo are shipped four units per pallet. This shipping methodology reduces the number of freight pieces by 50%. This reduces freight costs, labor to remove shipping material, and dunnage removal expenses (See Figure 1).

### Cabinets can be shipped in two ways,

1. Standing upright, cabinets are packaged in shrink wrap and are shipped four cabinets per pallet (See Figure 1)
2. Laid horizontally with risers attached. Due to risers extending both below and above the cabinet anytime risers are attached to the cabinets horizontal shipping with the use of a flat bed truck is required. The number of cabinets per pallet can vary based on size and quantity mix (See shipping tables 2 and 2a below). Pallets are shrink wrapped and a tarp is applied over the products for added protection during transit.

### Risers can be shipped in two ways,

1. Shipped horizontally attached to the cabinet. See cabinet shipping option 2 above for details
2. Shipped horizontally in a crate. Risers are crated by themselves and can be shipped independently from cabinets allowing for early installation. Risers shipping in a crate separately requires the use of a flat bed truck. The number of risers per pallet can vary based on diameter and quantity mix (See shipping table 3 below). Pallets are reinforced with a custom wood frame and packaging (See Shipping Figure 4 below).

Chassis, cabinets, and risers are palletized to maximize shipping density. The logic used for grouping is unit size by sales order.

Special shipping accommodations can be provided. Please see the Pre-Engineered factory design specials section for more details on this. Some examples include, palletizing by floor, palletizing by riser, end fork pallets, and reduced number of units per pallet.

## Shipping Table 1 – Standard Chassis

Vertical Shipping									
Description	Size	Multi-pack			Qty Per Pallet	Multi-pack Weight (lbs)	Multi-pack Weight (kg)	Pallet Stacking	Approx. Qty Per 53' Box Trailer
		Length	Width	Height					
Chassis	09-12	41	41	50	4	430	195	2 High	240
	15-18	43	43	50	4	542	246	2 High	240
	24-36	53	53	52	4	786	357	2 High	192
Cabinets	65" 09-12	41	41	72	4	422	192	1 High	112
	65" 15-18	43	43	72	4	466	212	1 High	112
	65" 24-36	53	53	72	4	650	295	1 High	72
Chassis Shipped In Cabinets	65" 09-12	41	41	72	4	830	377	1 High	112
	65" 15-18	43	43	72	4	986	447	1 High	112
	65" 24-36	53	53	72	4	1,410	640	1 High	72

ClimateMaster works continually to improve its products. As a result, the design and specifications of each product at the time of order may be changed without notice and may not be as described herein. Please contact ClimateMaster's Customer Service Department at 1-405-745-6000 for specific information on the current design and specifications. Statements and other information contained herein are not express warranties and do not form the basis of any bargain between the parties, but are merely ClimateMaster's opinion or commendation of its products. The latest version of this document is available at [climatemaster.com](http://climatemaster.com). © ClimateMaster, Inc. All rights reserved 2014

Shipping Table 1a – Hybrid Series

Vertical Shipping										
Description	Size	Multi-pack			Qty Per Pallet	Multi-pack Weight (lbs)	Multi-pack Weight (kg)	Pallet Stacking	Approx. Qty Per 53' Box Trailer	
		Length	Width	Height						
Chassis	09-12	48	41	50	4	562	255	2 High	208	
	15-18	51	45	50	4	762	346	2 High	192	
	24-36	61	55	52	4	984	447	2 High	80	
Cabinets	No Supply Flanges	65" 09-12	48	41	72	4	498	226	1 High	104
		65" 15-18	51	45	72	4	550	250	1 High	96
		65" 24-36	61	55	72	4	628	285	1 High	40
	No Supply Flanges	80" 09-12	48	41	87	4	550	250	1 High	104
		80" 15-18	51	45	87	4	606	275	1 High	96
		80" 24-36	61	55	87	4	696	316	1 High	40
	Supply Flanges Installed	80" 09-12	48	41	87	4	550	250	1 High	104
		80" 15-18	51	45	87	4	606	275	1 High	96
		80" 24-36	61	55	87	4	696	316	1 High	40
	No Supply Flanges	88" 09-12	48	41	95	4	582	264	1 High	104
		88" 15-18	51	45	95	4	642	292	1 High	96
		88" 24-36	61	55	95	4	736	334	1 High	40
	Supply Flanges Installed	88" 09-12	48	41	95	4	582	264	1 High	104
		88" 15-18	51	45	95	4	642	292	1 High	96
		88" 24-36	61	55	95	4	736	334	1 High	40
Chassis Shipped In Cabinets	No Supply Flanges	65" 09-12	48	41	72	4	1026	466	1 High	104
		65" 15-18	51	45	72	4	1274	578	1 High	96
		65" 24-36	61	55	72	4	1540	699	1 High	40
	No Supply Flanges	80" 09-12	41	41	87	4	886	402	1 High	104
		80" 15-18	43	43	87	4	1,078	489	1 High	96
		80" 24-36	53	53	87	4	1,482	672	1 High	40
	Supply Flanges Installed	80" 09-12	41	41	87	4	886	402	1 High	104
		80" 15-18	45	45	87	4	1,078	489	1 High	96
		80" 24-36	56	53	87	4	1,482	672	1 High	40
	No Supply Flanges	88" 09-12	41	41	95	4	942	427	1 High	104
		88" 15-18	43	43	95	4	1,138	516	1 High	96
		88" 24-36	53	53	95	4	1,542	700	1 High	40
	Supply Flanges Installed	88" 09-12	41	41	95	4	942	427	1 High	104
		88" 15-18	45	45	95	4	1,138	516	1 High	96
		88" 24-36	56	53	95	4	1,542	700	1 High	40

Shipping Table 2 – E Cabinet Series

Horizontal Shipping								
Description	Size	Multi-pack			Qty per pallet	Multi-pack Approx. Weight (lbs)	Multi-pack Approx. Weight (kg)	Pallet Stacking*
		Length	Width	Height				
Cabinets	65" 09-12	127	58	87	6	1046	475	2 High
	65" 15-18	127	58	93	6	1118	507	2 High
	65" 24-36	127	68	76	4	906	411	2 High
	80" 09-12	127	58	87	6	1,199	544	2 High
	80" 15-18	127	58	93	6	1,277	580	2 High
	80" 24-36	127	68	76	4	1,016	461	2 High
	88" 09-12	127	58	87	6	1,247	566	2 High
	88" 15-18	127	58	93	6	1,331	604	2 High
88" 24-36	127	68	76	4	1,056	479	2 High	

\* Warehousing purposes only, pallets are shipped 1 High

Shipping Table 2a – D Cabinet Series

Horizontal Shipping								
Description	Size	Multi-pack			Qty per pallet	Multi-pack Approx. Weight (lbs)	Multi-pack Approx. Weight (kg)	Pallet Stacking*
		Length	Width	Height				
Cabinets	65" 09-12	127	53	87	8	1150	522	2 High
	65" 15-18	127	53	93	8	1230	558	2 High
	65" 24-36	127	63	76	6	1262	573	2 High

\* Warehousing purposes only, pallets are shipped 1 High

Shipping Table 3

RISER SHIPPING									
Nominal Size (in.)	Pallet			# of Non-Insulated Layers per Pallet	# of Non-Insulated Risers per Pallet	# of Insulated Layers per Pallet	# of Insulated Risers per Pallet	Pallet Stacking	Qty Pallets Per 48' Flat Bed Trailer
	Length (in.)	Width (in.)	MAX Height (in.) *						
1	120	50	48	25	300	19	228	2 High	8
1.25	120	50	48	22	220	17	170	2 High	8
1.5	120	50	48	19	190	15	150	2 High	8
2	120	50	48	15	150	12	120	2 High	8
2.5	120	50	48	12	108	11	99	2 High	8
3	120	50	48	11	88	9	72	2 High	8
4	120	50	48	8	64	7	56	2 High	8

Calculations based on all palletized risers having the same nominal diameter size. Actual number of risers per pallet and number will vary based on riser diameter and insulation attachment mix.

\* - Includes the top pallet piece, bottom pallet piece, 0.25" cardboard dividers between each layer, and 0.375" thick tubing insulation (if applicable)

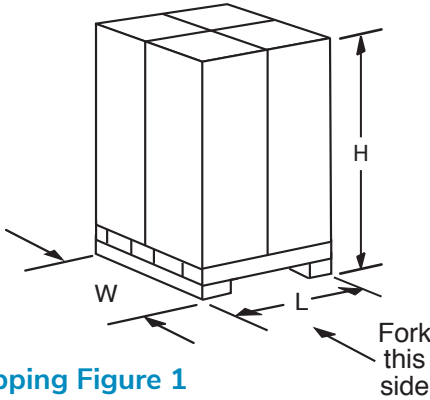

Shipping Figure 1

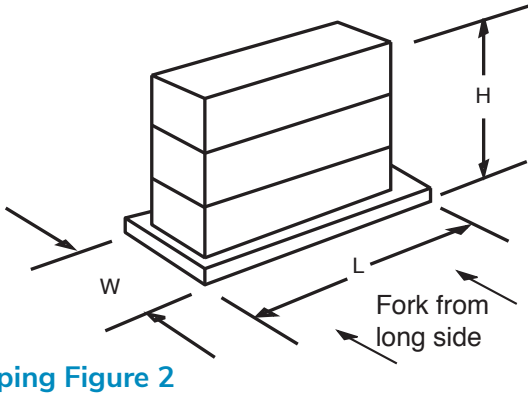

Shipping Figure 2

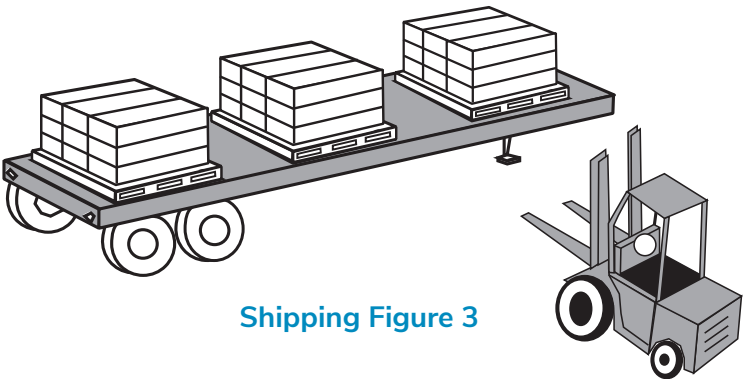

Shipping Figure 3

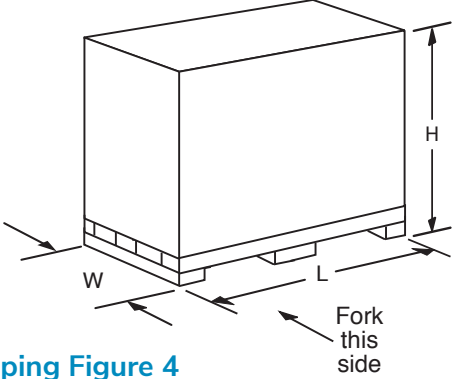

Shipping Figure 4

# Tranquility® Vertical Stack TSL Series Engineering Specifications – Page 1

## General:

Furnish and install ClimateMaster Tranquility® “TSL Vertical Stack” Water Source Heat Pumps, as indicated on the plans with capacities and characteristics as listed in the schedule and the specifications that follow.

Units shall be supplied completely factory built capable of operating over an entering water temperature range from 20° to 120°F (-6.7° to 48.9°C) as standard. Equivalent units from other manufacturers may be proposed provided approval to bid is given 10 days prior to bid closing. All equipment listed in this section must be rated and certified in accordance with Air-Conditioning, Heating and Refrigeration Institute/International Standards Organization (AHRI/ISO 13256-1). All equipment must be tested, investigated, and determined to comply with the requirements of the standards for Heating and Cooling Equipment UL-1995 for the United States and CAN/CSA-C22.2 NO.236 for Canada, by Intertek Testing Laboratories (ETL). The units shall have AHRI/ISO and ETL-US-C labels.

All units shall pass a factory acceptance test. The quality control system shall automatically perform the factory acceptance test via computer. A detailed report card from the factory acceptance test shall ship with each unit. **(Note: If unit fails the factory acceptance test, it shall not be allowed to ship. Unit serial number shall be recorded by factory acceptance test and furnished on report card for ease of unit warranty status.)**

## Cabinet Construction:

The cabinet panels shall be fabricated from heavy gauge galvanized steel. The rigid one-piece cabinet assembly shall be constructed so that it is self-supporting, and can be installed prior to the chassis arrival, and to be able to avoid damage during construction. Cabinet shall have a full panel over the chassis opening for structural rigidity of the cabinet; **no “open” top or “open” bottom designs allowed.**

The cabinet base shall contain a secondary drain pan fully insulated with a pressure differential drain trap connected to the condensate riser pipe, and guide rails for the slide in refrigeration chassis. Drain pan to be rubber grommet mounted to provide isolation of chassis from the cabinet. Drain pan(s) shall be easily accessible for cleaning. All interior surfaces shall be lined with 1/2 inch (12.7 mm) thick, 1-1/2 lb/ft<sup>3</sup> (24 kg/m<sup>3</sup>) acoustic type fiberglass insulation. All insulation shall be foil faced and have exposed edges butted up to flanges to prevent the introduction of glass fibers into the air stream.

Standard insulation must meet NFPA Fire Hazard Classification requirements 25/50 per ASTM E84, UL 723, CAN/ULC S102-M88 and NFPA 90A requirements; air erosion and mold growth limits of UL-181; stringent fungal resistance test per ASTM-C1071 and ASTM G21; and shall meet zero level bacteria growth per ASTM G22. **Unit insulation must meet these stringent requirements or unit(s) will not be accepted.**

Standard is 1 inch (25 mm) filter holder with 1inch (25 mm) thick fiberglass throwaway filter.

**Option: 2 inch (50 mm) filter holder with 2 inch (50 mm) thick fiberglass throwaway filter.**

**Pre-Engineered Special: Integrated fresh air intake. Removes the need for field attachment of fresh air assembly. Does not increase the cabinet footprint. Available with cabinet side connection only.**

Cabinet arrangements shall allow placement of riser piping on any one of the three sides of the cabinet not used for the chassis access and air supply. All cabinets shall have supply air knockouts on all sides and top. Return air K.O. to be removed from panel behind the filter. Field shall configure cabinets by removing factory knockouts and install duct flanges per model configuration shown on plans. For air noise attenuation purposes, the discharge air from fan shall discharge into insulated plenum that also contains x-shape painted air baffle. Units not having supply air noise baffles are not acceptable. Cabinet design shall allow a full height base board (4.50 inches/114 mm) beneath the return air “G” panel. The cabinet shall contain an easily removable motor/blower assembly.

# Tranquility® Vertical Stack TSL Series Engineering Specifications – Page 2

**Option:** Factory to configure supply air openings, remove K.O., cut insulation, and install duct angles. With dust protection, includes capping supply air openings and leaving K.O. in panel behind filter (installer to remove both).

Electrical conduit shall be installed from electrical unit control compartment to top of cabinet for low voltage control wiring as well as separate conduit for main power wiring. **Units without these two factory installed electric conduits will not be accepted.**

**Option:** Leader and follower cabinets.

**Option:** Required installation vibration isolation pad to be applied at the factory to the bottom of the cabinet if not field provided.

**Option:** Cabinet height 80" or 88" (203 or 223 cm)

**Pre-Engineered Special:** Extended cabinet heights

**Option:** Construction for unit mounted Thermostat (thermostat ordered separate) -- includes junction box mounted outside discharge plenum and has a Molex-type connector inside for quick connection to A91558 Series thermostat. The A91558 series use thermostat models ATA11U01, ATA11U03, ATA22U01, ATP21W02, ATP21W02, ATP21W02, ATP32U03C, AWC99U01, ATA32V01, AVB32V02C, AVB32V03C respectively with mating molex-type connector.

**Pre-Engineered Special:** Custom thermostat whips for connection to 3rd party provided thermostats.

**Option:** Low voltage 15, 25, or 35 foot (572, 762, or 1,067 cm) wire harness (whip) with molex-type connector for connection to remote mounted thermostat. For use with A91558 thermostat series (see above).

**Pre-Engineered Special:** Extended thermostat whips for remote thermostat location in excesses of the 35' from the cabinet.

**Option:** Cabinet to have wire harness for connection to A91558 series thermostat mounted to ADA "G" return air panel.

**Option:** Premium automotive grade rubber seal between cabinet inner panel and chassis.

Full-length supply, return, and insulated condensate water risers shall be type M copper. Riser length up to 120 inch (305 cm) is standard. Supply and return risers have integral internal piping including ball valves (for shut off purposes at unit). Risers and piping shall be factory pressure tested to check for leaks. Field installed hose kits are required to connect the chassis piping to the cabinet ball valve. The condensate riser shall be insulated with 3/8-inch (9.5 mm) Armaflex type insulation. The top of each riser shall be deeply swaged (3 inch/76.2 mm) to accept connection to the riser above/below, allowing for a floor to floor dimensional variance of ± one inch (25.4 mm). **Units not having swaged riser-piping connections shall not be acceptable. Couplings and trim pieces shall not be allowed.**

**Option:** Bulk ship risers so complete riser stack can be installed, pressure tested, and filled before the cabinets are installed.



# Tranquility® Vertical Stack TSL Series Engineering Specifications – Page 3

**Pre-Engineered Special:** Risers/Cabinets/Chassis shipped by floor. This helps with job site delivery coordination.

**Option:** Type L riser piping.

**Option:** Supply and return risers insulated with 3/8-inch (9.5 mm) ARMAFLEX (closed cell) type insulation. 1 inch through 3-inch diameter standard, 4-inch diameter available.

**Option:** Non-swaged riser piping for crimp (non-brazed) style connections.

**Pre-Engineered Special:** Risers for single pipe applications. Supply and return water lines are combined into one riser configuration.

**Pre-Engineered Special:** Riser connection location moved lower. Standard riser connections are made above the cabinets. This requires the use of a ladder or scaffolding to get access to the connection. Riser connection locations are moved lower so that connections can be made at the ground level. Risers must be shipped separately.

**Pre-Engineered Special:** Riser manual air vents. Allow for air to be purged from the riser stack during commissioning.

**Pre-Engineered Special:** Extended risers. Removes the need for riser extension pieces which results in less field connections.

**Pre-Engineered Special:** Remove drain riser. This is needed when condensate drain risers are field provided.

**Pre-Engineered Special:** Riser bypass valve. Allows water flow from supply to return riser during pressurization prior to the chassis being installed.

## **Fan and Motor Assembly:**

The cabinet shall contain a removable motor/blower assembly. Units shall have a direct drive centrifugal fan. The fan motor shall be 3 speed, permanently lubricated, PSC type with thermal overload protection. The fan motor for small size units (09 and 12) shall be isolated from the fan housing by a torsionally flexible motor mounting system with rubber type grommets to inhibit vibration induced high noise levels associated with “hard wire belly band” motor mounting. The fan motor on medium and large units (15-36) shall be isolated with flexible rubber type isolation grommets only. Airflow/External static pressure rating of the unit shall be based on a wet coil and clean filter. **Ratings based on a dry coil and/or no air filter shall not be acceptable.**

**Option:** Constant Volume (CV) ECM variable speed ball bearing type motor. The CV ECM fan motor shall provide soft starting, maintain constant CFM over its static operating range and provide airflow adjustment in 25 CFM increments via its control board. The fan motor shall be isolated from housing by rubber grommets. The motor shall be permanently lubricated and have thermal overload protection. A special dehumidification mode shall be provided to allow lower airflows in cooling for better dehumidification. The dehumidification mode may be constant or automatic (humidistat controlled).

# Tranquility® Vertical Stack TSL Series Engineering Specifications – Page 4

**Option:** Constant Torque (CT) ECM. The fan motor shall be isolated from housing by rubber grommets. The motor shall be permanently lubricated and have thermal overload protection.

## **Chassis:**

The chassis, which incorporates the air coil, water coil, drain pan with solid-state electronic condensate overflow protection, compressor, and electrical components shall be easily installed for quick jobsite installation and future servicing purposes. The slide in chassis shall have insulated panels surrounding the compressor. Compressors are not in the air stream. The chassis base shall be fabricated from heavy gauge galvanized steel formed to match the slide in rails of the cabinet. Units shall have a factory installed 1 inch (25.4 mm) thick filter bracket and throwaway type glass fiber filter. Furnish one spare set of filters.

**Option:** Chassis can ship upright in any cabinet that risers are not attached.

**Option:** UltraQuiet package shall consist of the standard double isolation of the compressor plus sound attenuating compressor blanket applied to the compressor. All sheet metal surrounding the compressor shall have high density sound attenuating material with STC rating of 26 per ASTM E-90 and then covered with fiberglass insulation.

**Option:** Factory wired for communicating thermostat, requires AWC99U01 thermostat.

**Option:** Rib relay replaces contactor for models 09 through 18. Eliminates contactor “click” when first energized.

**Option:** vFlow® The unit will be supplied with internally factory mounted modulating water valve with delta T control. The factory built-in valve shall modulate water flow through unit based on a field adjustable water temperature difference between the entering and leaving water. The valve shall automatically adjust for operating mode, source water temperature and variations in external head pressure. The valve will also act as a shut-off valve to prevent water flow through the unit when the unit is not activated and will have a minimum position capability.

**Option:** Factory installed 3-way water valve. Valves are used on units at the end of a riser water loop to ensure continuous flow between supply and return riser stacks when those units are not in operation. This prevents excessive water flow and pressure drop through the coax when it is not in operation.

**Pre-Engineered Special:** Internally factory mounted water loop strainer. Strainers filter water to ensure debris does not enter the unit coaxial heat exchanger. Debris in water loops can degrade thermal transfer (efficiency) and potentially limit water flow. Please consult TSL IOM for proper care and maintenance of strainers when selecting this option.

**Pre-Engineered Special:** Supply and Return P/T ports. Allows the for the water pressure drop to be checked across the heat exchanger which can be correlated to a fluid flow rate. Technicians can use this feature to determine if there is proper water flow through the unit.

**Option:** The unit will be supplied with internally factory mounted two-way motorized water valve (MWV) for variable speed loop pumping requirements. Valve to be fail closed type. Water circuit will have factory installed high pressure switch located between MWV and heat exchanger.

# Tranquility® Vertical Stack TSL Series Engineering Specifications – Page 5

**Option:** The unit will be supplied with internally factory mounted automatic water flow regulators.

**Option:** The unit will be supplied with internally factory mounted secondary pump rated for 200 PSIG applications.

Water connections between chassis and the cabinet shall be accomplished via a hose kit consisting of Kevlar-reinforced EPDM core hose surrounded by a stainless-steel braid. Hose kit shall have brass fittings with stainless-steel ferrules. AHU hose ends shall be Internal NPSH (National Pipe Straight Hose) swivel ends with EPDM washers which connect to mating threaded end connection on chassis and riser ball valve. The hose kit shall be rated for 400 psi (2,756 kPa) design working pressure.

## Refrigerant Circuit:

All units shall contain an EarthPure® (HFC-410A) sealed refrigerant circuit including a high efficiency scroll or rotary compressor designed for heat pump operation, a thermostatic expansion valve for refrigerant metering, an enhanced corrugated aluminium lanced fin and rifled copper tube refrigerant to air heat exchanger, reversing valve, coaxial (tube in tube) refrigerant to water heat exchanger, and safety controls including a high pressure switch, low pressure switch (loss of charge), water coil low temperature sensor, and air coil low temperature sensor. Access fittings shall be factory installed on high- and low- pressure refrigerant lines to facilitate field service. Activation of any safety device shall prevent compressor operation via a microprocessor lockout circuit. The lockout circuit shall be reset at the thermostat or at the contractor supplied disconnect switch. **Units that cannot be reset at the thermostat shall not be acceptable.**

Hermetic compressors shall be internally sprung and externally isolated. The compressor shall have a dual level vibration isolation system. The compressor will be mounted on specially engineered sound-tested EPDM vibration isolation grommets to a large heavy gauge compressor base pan, which is then isolated from the cabinet by resting on condensate drain pan which is isolated by grommets for maximized vibration attenuation. All units (except units with rotary compressors) shall include a discharge muffler to further enhance sound attenuation. Compressor shall have thermal overload protection.

Refrigerant to air heat exchangers shall utilize enhanced corrugated lanced aluminium fins and rifled copper tube construction rated to withstand 625 PSIG (4309 kPa) refrigerant working pressure. Copper hairpins are tin electroplated for added protection from formicary corrosion. **Units that do not have tin-plated hairpins shall not be acceptable.**

Refrigerant to water heat exchangers shall be of copper inner water tube and steel refrigerant outer tube design, rated to withstand 625 PSIG (4,309 kPa) working refrigerant pressure and 500 PSIG (3,445 kPa) working water pressure. The refrigerant to water heat exchanger shall be "electro-coated" with a low cure cathodic epoxy material a minimum of 0.4 mils thick (0.4 – 1.5 mils range) on all surfaces. The black colored coating shall provide a minimum of 1,000 hours salt spray protection per ASTM B117-97 on all external steel and copper tubing. The material shall be formulated without the inclusion of any heavy metals and shall exhibit a pencil hardness of 2H (ASTM D3363-92A), crosshatch adhesion of 4B-5B (ASTM D3359-95), and impact resistance of 160 in-lbs (184 kg-cm) direct (ASTM D2794-93).

Refrigerant metering shall be accomplished by thermostatic expansion valve only. Expansion valves shall be dual port balanced types with external equalizer for optimum refrigerant metering. Units shall be designed and tested for operating ranges of entering water temperatures from 20° to 120°F (-6.7° to 48.9°C). Reversing valve shall be four-way solenoid activated refrigerant valve, which shall default to heating mode should the solenoid fail to function. If the reversing valve solenoid defaults to cooling mode, an additional low temperature thermostat must be provided to prevent over-cooling an already cold room.

**Option:** The unit will be supplied with non-plated air to refrigerant heat exchanger.

**Option:** The unit will be supplied with cupro-nickel coaxial water to refrigerant heat exchanger.

# Tranquility® Vertical Stack TSL Series Engineering Specifications – Page 6

## Cabinet Drain Pan:

The drain pan shall be constructed of galvanized steel and have a powder coat paint application to further inhibit corrosion. This corrosion protection system shall meet the stringent 1,000-hour salt spray test per ASTM B117. Drain pan to be isolated from cabinet with four EPDM vibration isolation grommets. If plastic type material is used, it must be HDPE (High Density Polyethylene) to avoid thermal cycling shock stress failure over the lifetime of the unit. Drain pan shall be fully insulated. Drain pan shall have at a minimum a doubled sloped surface to allow positive drainage to the outlet opening, which shall be at the lowest level of the entire pan surface. Drain outlet shall be connected from pan outlet to condensate riser (if supplied) with factory installed trap inside of cabinet. The cabinet drain pan as standard will be supplied with solid-state electronic condensate overflow protection. Drain pans that are not isolated from cabinet shall not be acceptable. Mechanical float switches will NOT be accepted.

## Option: Stainless steel drain pan

## Electrical:

A control compartment shall be located within the chassis and shall contain a 50VA transformer, 24 volts activated, 2 pole compressor contactor, relay and solid-state controller for complete unit operation. Reversing valve and fan motor wiring shall be routed through this electronic controller. Units shall be name-plated for use with time delay fuses or HACR circuit breakers. Unit controls shall be 24 Volt and provide heating or cooling as required by the remote thermostat/sensor. A control compartment shall be located within the cabinet and shall contain a terminal block for high voltage connections. All electrical connections between the chassis and cabinet shall be made via locking quick-connects.

## Option: Disconnect Switch, Non-Fused, classified as motor disconnect.

## Option: Circuit Breaker, all 208/230 volt and 265 volt, 15 and 20 amp - HACR rated, 265-volt 25 amp and higher - supplemental rated.

## Enhanced Solid State Control System (CXM2):

Units shall have a solid-state control system. Units utilizing electro-mechanical control shall not be acceptable. The control system microprocessor board shall be specifically designed to protect against building electrical system noise contamination, EMI, and RFI interference. The control system shall interface with a heat pump type thermostat. The control system shall have the following features:

- a. Anti-short cycle time delay on compressor operation.
- b. Random start on power up mode.
- c. Low voltage protection.
- d. High voltage protection.
- e. Unit shutdown on high or low refrigerant pressures.
- f. Unit shutdown on low water temperature.
- g. Condensate overflow electronic protection.
- h. Option to reset unit at thermostat or disconnect.
- i. Automatic intelligent reset. Unit shall automatically reset the unit 5 minutes after trip if the fault has cleared. If a fault occurs 3 times sequentially without thermostat meeting temperature, then lockout requiring manual reset will occur.
- j. Ability to defeat time delays for servicing.
- k. The low-pressure switch shall not be monitored for the first 120 seconds after a compressor start command to prevent nuisance safety trips.
- l. 24V output to cycle a motorized water valve or other device with compressor contactor.
- m. Unit Performance Sentinel (UPS). The UPS warns when the heat pump is running inefficiently.
- n. Water coil low temperature sensing (selectable for water or anti-freeze).

# Tranquility® Vertical Stack TSL Series Engineering Specifications – Page 7

- o. Air coil low temperature sensing.
- p. Minimized reversing valve operation (Unit control logic shall only switch the reversing valve when cooling is demanded for the first time. The reversing valve shall be held in this position until the first call for heating, ensuring quiet operation and increased valve life).
- q. Emergency shutdown contacts.
- r. Entering and leaving water temperature sensing.
- s. Leaving air temperature sensing.
- t. Compressor discharge temperature sensing.

**NOTE: Units not providing the 8 safety protections of anti-short cycle, low voltage, high voltage, high refrigerant pressure, low pressure (loss of charge), air coil low temperature cut-out, water coil low temperature cut-out, and condensate overflow protections will not be accepted.**

When CXM2 is connected to AWC99U01 thermostat or handheld service tool, the installer/service technician can; check DIP Switch S2 settings; run operation modes manually; check all physical inputs from thermostat and refrigerant pressure switches status, (Y1, Y2, W, O, G, H, ESD, NSB, OR, HP switch, and LOC switch); current or at time of fault the following temperatures - water coil (LT1), air coil (LT2), compressor discharge, leaving air, leaving water, entering water and control voltage; record last five faults, list possible reasons, and clear faults. When the AWC99U01 communicating thermostat is used this same functionality can be viewed and adjusted remotely in the web portal or mobile app. **Systems not providing remote access, diagnosis, and adjustment functionality will not be accepted.**

## Option: Enhanced Solid State Control System (DXM2.5)

This control system is a communicating controller.

Control shall have the above-mentioned features of the CXM2 control system along with the following expanded features:

- a. Removable thermostat connector.
- b. Night setback control.
- c. Random start on return from night setback.
- d. Override temperature control with 2-hour timer for room occupant to override setback temperature at the thermostat.
- e. Dry contact night setback output for digital night setback thermostats.
- f. Ability to work with heat pump or heat/cool (Y, W) type thermostats.
- g. Ability to work with heat pump thermostats using O or B reversing valve control.
- h. Boilerless system heat control at low loop water temperature.
- i. Ability to allow up to 3 units to be controlled by one thermostat.
- j. Relay to operate an external damper.
- k. Relay to start system pump.
- l. 75 VA control transformer. Control transformer shall have load side short circuit and overload protection via a built-in circuit breaker.

**NOTE: Units not providing the 8 safety protections of anti-short cycle, low voltage, high voltage, high refrigerant pressure, low pressure (loss of charge), air coil low temperature cut-out, water coil low temperature cut-out, and condensate overflow protection for both drain pans will not be accepted.**

When DXM2.5 is connected to AWC99U01 communicating thermostat or handheld service tool, the installer/service technician can; check and set CFM; check DIP Switch S1, S2, and S3 settings; run operation modes manually; check all physical inputs from thermostat and refrigerant pressure switches status, (Y1, Y2, W, O, G, H, ESD, NSB, OR, HP switch, and LOC switch); current or at time of fault the following temperatures - water coil (LT1), air coil (LT2), compressor discharge, leaving air, leaving water, entering water and control

# Tranquility® Vertical Stack TSL Series Engineering Specifications – Page 8

voltage; record last five faults, list possible reasons, and clear faults. When the AWC99U01 communicating thermostat is used this same functionality can be viewed and adjusted remotely with the only portal or mobile app. **Systems not providing remote access, diagnosis, and adjustment functionality will not be accepted.**

## Digital Night Setback with Pump Restart (DXM2.5 w/ ATP32U03C/04C, AWC99U01):

The unit will be provided with a Digital Night Setback feature using an accessory relay on the DXM2.5 controller with an ATP32U03C/04C or AWC99U01 thermostat and an external, field-provided time clock. The external time clock will initiate and terminate the night setback period. The thermostat will have a night setback override feature with a programmable override time period.

An additional accessory relay on the unit DXM2.5 controller will energize the building loop pump control for the duration of the override period. **(Note: This feature requires additional low voltage wiring. Consult Application Drawings for details.)**

## Remote Service Sentinel (CXM2/DXM2.5):

Solid state control system shall communicate with applicable thermostats to display (at the thermostat) the unit status, fault status, and specific fault condition, as well as retrieve previously stored fault that caused unit shutdown. The Remote Service Sentinel allows building maintenance personnel or service personnel to diagnose unit from the wall thermostat. The control board shall provide a signal to the thermostat, indicating a lockout. A detailed message shall be provided at the communicating thermostat or service tool and specific fault status such as over/under voltage fault, high pressure fault, low pressure fault, low water temperature fault, condensate overflow fault, etc. **Units that do not provide this remote service sentinel shall not be acceptable.**

## Option: MPC (Multiple Protocol Control) Interface System

Units shall have all the features listed above (either CXM2 or DXM2.5) and the control board will be supplied with a Multiple Protocol interface board. Available protocols are BACnet MS/TP, Modbus, or Johnson Controls N2. The choice of protocol shall be field selectable/changeable via the use of a simple selector switch. Protocol selection shall not require any additional programming or special external hardware or software tools. This will permit all units to be daisy chain connected by a 2-wire twisted pair shielded cable. The following points must be available at a central or remote computer location:

- a. Space temperature
- b. Leaving water temperature
- c. Discharge air temperature
- d. Command of space temperature setpoint
- e. Cooling status
- f. Heating status
- g. Low temperature sensor alarm
- h. Low pressure sensor alarm
- i. High pressure switch alarm
- j. Condensate overflow alarm
- k. Hi/low voltage alarm
- l. Fan "ON/AUTO" position of space thermostat as specified above
- m. Unoccupied/occupied command
- n. Cooling command
- o. Heating command
- p. Fan "ON/AUTO" command
- q. Fault reset command
- r. Itemized fault code revealing reason for specific shutdown fault (any one of 7)

# Tranquility® Vertical Stack TSL Series Engineering Specifications – Page 9

This option also provides the upgraded 75 VA control transformer with load side short circuit and overload protection via a built-in circuit breaker.

## Return Panels:

The “G” return AR panel assembly shall be architecturally designed, acoustic type, with one-piece frame and hinged door for easy and quick access to filter. Assembly is attached to the cabinet with 4 bolts which can be easily removed for chassis access. The hinged return panel shall be made of heavy gauge die formed galvanized steel with a powder coat finish in “Polar Ice” or special color. Return air panels that protrude from wall more than 5/8 inch (15.9 mm) are not acceptable.

**Option:** Return air panel painted “Bright White” color

**Pre-Engineered Special:** Custom painting of return air panels per field specified color.

**Option:** “G” panel with mounting for ADA thermostat allows thermostat to be mounted low to comply with ADA height requirement.

**Pre-Engineered Special:** Custom return air panel knock outs for ADA mounted 3rd party provided thermostats.

**Pre-Engineered Special:** ADA return air panels with knock out moved lower. Needed when cabinets are placed on unit stands to comply with ADA maximum thermostat height.

**Option:** “G” panel with keyed locks - prevents users from tampering with units.

**Option:** Style “G” return air panel with frame for recessing cabinet behind finished wall.

**Option:** Motorized fresh air damper for “G” panel with frame - allows outside air to enter on right or left side.

**Option:** Flush Mounted “L” panel. Offered in Bright White and Polar Ice color option. Allows for chassis to be removed without removing the frame.

## Supply Grille(s):

Supply grille(s) shall be architecturally designed “brushed” aluminium or powder coated finish in “Polar Ice” color.

**Option:** Supply grille painted “Bright White”.

**Option:** Supply grille with double deflection style louvers.

**Option:** Supply grille with double deflection style louvers with opposed damper.

## Warranty:

ClimateMaster shall warranty equipment for a period of 12 months from start up or 18 months from shipping (which ever occurs first).

**Option:** Extended 4-year compressor warranty covers compressor for a total of 5 years.



# Tranquility® Vertical Stack TSL Series Engineering Specifications – Page 10

**Option:** Extended 4-year refrigeration circuit warranty covers coils, reversing valve, expansion valve and compressor for a total of 5 years.

**Option:** Extended 4-year control board warranty covers the CXM2/DXM2.5 control board for a total of 5 years.

## FIELD INSTALLED OPTIONS

### Hose Kits (required for field water connections):

Water connections between chassis and the cabinet shall be accomplished via a hose kit consisting of Kevlar-reinforced EPDM core hose surrounded by a stainless-steel braid. Hose kit shall have brass fittings with stainless-steel ferrules. The hose kit shall be rated for 400 psi (2,756 kPa) design working pressure. The AHU hose kits are required for each cabinet.

### Cabinet Stands - ACST Series:

Cabinet stands are used when applications have baseboards with heights taller than 4 inches. Heavy 16-gauge galvanized steel construction, bolts to bottom of cabinet. Heights 1-inch (25 mm) to 13-inch (330 mm) by 1-inch (25 mm) increments. Ships in bulk for field attachment.

**Pre-Engineered Special:** Cabinet stands factory assembled and attached to the cabinet.

### Filters:

Pleated media disposable 1 inch (25 mm) thick MERV 8 or MERV 11, 2 inches (50 mm) thick MERV 8, MERV 11 or MERV 13.

### Thermostats:

The thermostat shall be a ClimateMaster electronic type thermostat as selected below with the described features:

**Note:** To achieve full benefit of controls, use 2 speed thermostats (switch for manual or Y2 for automatic change).

#### a. Thermostat (Communicating) (AWC99U01)

An electronic communicating web-enabled touchscreen thermostat shall be provided. The thermostat shall offer three stages of heating and two stages of cooling with precise temperature control and have a four-wire connection to the unit. The thermostat shall be capable of manual or automatic change-over operation and shall operate in standard or programmable mode. An integrated humidity control feature shall be included to control a humidifier and/or a dehumidifier. The thermostat shall include a utility demand reduction feature to be initiated by an independent time program or an external input.

The thermostat shall provide access to via the web portal or mobile application to include temperature adjustment, schedule adjustment including occupied/unoccupied, entering water temperature, leaving water temperature, water coil temperature, air coil temperature, leaving air temperature, and compressor discharge temperature. A graphical system layout to be provided with real-time operating mode information of the temperature sensors for easy diagnostics.

The thermostat shall display system faults with probable cause and troubleshooting guidance. The system shall provide in clear language last five faults, time of faults, operating temps at time of fault, and possible reasons for the fault. The thermostat shall provide access for immediate manual control of all outputs via the web portal/mobile application for rapid troubleshooting.



# Tranquility® Vertical Stack TSL Series Engineering Specifications – Page 11

b. Single-Stage Digital Auto or Manual Changeover (ATA11U01)

Thermostat shall be a single-stage, digital, auto or manual changeover with HEAT-OFF-COOL-AUTO system switch and fan ON-AUTO switch. Thermostat shall have an LCD display with temperature and setpoint(s) in °F or °C. The Thermostat shall provide permanent memory of setpoint(s) without batteries. A fault LED shall be provided to display specific fault condition. Thermostat shall provide temperature display offset for custom applications.

c. Single Stage Digital Auto or Manual Changeover and Manual Two Fan Speed Selections (ATA11U03)

Thermostat shall be a single-stage, digital, auto or manual changeover with HEAT-OFF-COOL-AUTO system settings, high and low fan settings and fan ON-AUTO settings. Thermostat shall have an LCD display with temperature, setpoint(s), mode, and status indication. The temperature indication shall be selectable for °F or °C. The thermostat shall provide permanent memory of setpoint(s) without batteries. Thermostat shall provide heating setpoint range limit, cooling setpoint range limit, temperature display offset, keypad lockout, dead-band range setting, and inter-stage differential settings. Thermostat shall allow the use of an accessory remote temperature sensor (17B0008N05). Thermostat navigation shall be accomplished via 4 push buttons.

d. Multi-stage Digital Automatic Changeover (ATA22U01)

Thermostat shall be multi-stage (2H/2C), manual or automatic changeover with HEAT-OFF-COOL-AUTO-EM HEAT system settings and fan ON-AUTO settings. Thermostat shall have an LCD display with temperature, setpoint(s), mode, and status indication. The temperature indication shall be selectable for °F or °C. The thermostat shall provide permanent memory of setpoint(s) without batteries. A fault LED shall be provided to indicate specific fault condition(s). Thermostat shall provide temperature display offset for custom applications. Thermostat shall allow unit to provide better dehumidification with optional DXM2.5 controller by automatically using lower fan speed on stage 1 cooling (higher latent cooling) as main cooling mode, and automatically shifting to high-speed fan on stage 2 cooling. Thermostat can be configured to heat and cool even if in off mode (replaces night low limit switch (NLLS) in cabinet).

e. Multi-stage Manual Changeover Programmable 5/2 Day (ATP21W02)

Thermostat shall be 5 day/2 day programmable (with up to 4 setpoints per day), multi-stage (2H/1C), manual or automatic changeover with HEAT-OFF-COOL-EM HEAT system settings and fan ON-AUTO settings. Thermostat shall have an LCD display with temperature, setpoint(s), mode, and status indication. The temperature indication shall be selectable for °F or °C.

f. Multi-stage Automatic or Manual Changeover Programmable 7 Day (ATP32U03C)

Thermostat shall be 7 day programmable (with up to 4 setpoints per day), multi-stage (3H/2C), automatic or manual changeover with HEAT-OFF-COOL-AUTO-EM HEAT system settings and fan ON-AUTO settings. Thermostat shall have a blue backlit dot matrix LCD display with temperature, setpoints, mode, and status indication. The temperature indication shall be selectable for °F or °C. Time display shall be selectable for 12 or 24-hour clock. Fault identification shall be provided (when used with ClimateMaster CXM2 or DXM2.5 controls) to simplify troubleshooting by providing specific unit fault at the thermostat with red backlit LCD during unit lockout. The thermostat shall provide permanent memory of setpoints without batteries. Thermostat shall provide heating setpoint range limit, cooling setpoint range limit, temperature display offset, keypad lockout, dead-band range setting, and inter-stage differential settings. Thermostat shall provide progressive recovery to anticipate time required to bring space temperature to the next programmed event. Thermostat shall provide an installer setup for configuring options and for setup of servicing contractor name and contact information. Thermostat shall allow the use of an accessory remote and/or outdoor temperature sensor (AST008C). Thermostat navigation shall be accomplished via five buttons (up/down/right/left/select) with menu-driven selections for ease of use and programming.

g. CM100 - Multi-stage Automatic or Manual Changeover digital thermostat (ATA32V01)

Multi-stage (3H/2C), automatic or manual changeover with HEAT-OFF-COOL-AUTO-EM HEAT system settings and fan ONAUTO settings. Thermostat shall have a green backlit LED display with temperature, setpoints, mode, and status indication via a green (cooling) or red(heating) LED. The temperature indication shall be selectable for °F or °C. Time display shall be selectable for 12- or

# Tranquility® Vertical Stack TSL Series Engineering Specifications – Page 12

24- hour clock. The thermostat shall provide permanent memory of setpoints without batteries. Thermostat shall provide heating setpoint range limit, cooling setpoint range limit, temperature display offset, keypad lockout, dead-band range setting, and inter-stage differential settings. Thermostat shall provide progressive recovery to anticipate time required to bring space temperature to the next programmed event. Thermostat shall provide an installer setup for configuring. Thermostat navigation shall be accomplished via four buttons (Mode/fan/down/up) with menu-driven selections for ease of use and programming.

- h. CM300 – Multi-stage, Automatic or Manual Changeover, 7-day Programmable with Wi-Fi and Humidity Control (AVB32V02C)  
Residential version shall be 7 day programmable with up to 4 setpoints per day. Commercial version shall be 7 day programmable with 4 occupied/unoccupied periods per day with up to 4-hour override. Multi-stage (3H/2C), automatic or manual changeover with HEAT-OFF-COOL-AUTO-EM HEAT system settings and fan ON-AUTO settings, Wi-Fi, pre-occupancy purge fan option, night time control of display backlight, bi-color LED indicates a heating or cooling demand, keypad lock, title 24 compliant, openADR2.0b certified with Skyport web portal. Compatible with condensate overflow warning systems – lockout compressor with message on.
- i. CM500 – Color Touchscreen Display, Multi-stage, Automatic or Manual Changeover, 7-day Programmable with Wi-Fi and Humidity Control (AVB32V03C)  
Thermostat shall have color resistive touchscreen display with space temperature, relative humidity, setpoints, mode, status indication and local weather (if connected to Wi-Fi). Residential version shall be 7 day programmable with up to 4 setpoints per day. Commercial version shall be 7 day programmable with 4 occupied/unoccupied periods per day with up to 4-hour override. Multi-stage (3H/2C), automatic or manual changeover with HEAT-OFF-COOL-AUTO-EM HEAT system settings and fan ONAUTO settings, Wi-Fi, pre-occupancy purge fan option, customizable screen saver and background displays, indicator on display indicates a heating or cooling demand, set-point lock, title 24 compliant, openADR2.0b certified with Skyport web portal. Compatible with condensate overflow warning systems – lockout compressor with message on the display. Capable of being monitored by 3rd party software. Compatible with AST014 Wi-Fi remote sensor. Configurator mobile app or web portal for easy setup. Separate dehumidification and humidification setpoints shall be configurable for discreet outputs to a dehumidification option and/or an external humidifier. The temperature indication shall be selectable for °F or °C. Time display shall be selectable for 12- or 24-hour clock. The thermostat shall provide permanent memory of setpoints without batteries. Thermostat shall provide heating setpoint range limit, cooling setpoint range limit, temperature display offset, dead-band range setting, and inter-stage differential settings. Thermostat shall provide progressive recovery to anticipate time required to bring space temperature to the next programmed event. Thermostat shall provide access to a web portal and mobile app for installer setup for configuring options. Thermostat shall have menu-driven selections for ease of use and programming.

## DDC Sensors:

ClimateMaster wall mounted DDC sensor to monitor room temperature and interfaces with optional DDC interface system described above. Several types as described below:

- a. Sensor only with no display (MPC).
- b. Sensor with setpoint adjustment and override (MPC).
- c. Sensor with setpoint adjustment and override, LCD display, status/fault indication (MPC).

**NOTICE! This product specification document is furnished as a means to copy and paste ClimateMaster product information into project specification. It is not intended to be a complete list of product requirements. This document is an excerpt from the product submittal and must not be used without consulting the complete product submittal. For complete product installation and application requirements, please consult the complete product submittal. ClimateMaster is not responsible for misuse of this document or a failure to adequately review specific requirements in the product submittal.**

# Pre-Engineered Factory Design Specials

**In a fast pace ever changing market ClimateMaster is committed to working with our partners to bring solutions to their project challenges** and we do this in many

ways. We design our products to be extremely configurable, offer the widest range of product options, continually introduce new options, and support special design modification requests. When unique solutions are needed to support your project specific needs, ClimateMaster is here to be your partner!

In our years of experience we have supported many different requests. Below is a list commonly requested (pre-engineered) factory design specials we support:

- **Cabinets stands factory assembled and attached to the cabinet** – Saves labor and time in the field
- **Extended height cabinets** – Reduced ducting material; Supply air is discharged at a higher elevation (lengths limited)
- **Integrated fresh air intake** – Conditioned outside air can be ducted directly to the cabinet without the need for a field accessory and without extending the cabinets footprint
- **Single pipe risers** – Supply and return riser combined into one riser for single pipe applications
- **Riser to riser connection points moved lower** – Allows for brazing connection to be made without the use of a ladder or scaffolding
- **Supply and Return P/T ports** – Allows for water pressure drop to be checked across the heat exchanger which can be correlated to a fluid flow rate
- **Riser manual air vents** – Allow air to be purged from the system at the top of a riser stack
- **Extended riser lengths** – Removes the needed for extension pieces (lengths limited)
- **Remove drain riser** – When drain risers are field provided
- **Riser bypass valve** – Allows water flow from supply to return riser during pressurization prior to the chassis being installed
- **4" Risers** – Applications that need large amounts of water flow
- **Risers/Cabinets/Chassis shipped by floor** – Helps with job site delivery coordination
- **Extended thermostat whips** – Same labor/time saving solution but needed when remote thermostats are located more than 35' away
- **Custom thermostat whips** – Used for connection to 3rd party provided thermostats
- **ADA return air panels with custom knocks outs** – Needed with 3rd party provided thermostats are mounted to our return air doors
- **Customer return air panel colors** – Supports Architect/Designer/Owner requests
- **Strainers** – Collect debris in the water loop stopping it from entering the water heat exchanger

These are just a few of the product modifications we have supported for applications specific needs. To inquire about any of these preconfigured special options or any other solutions you need support with on your vertical high-rise project please contact your local ClimateMaster Representative: [Rep Locator](#).

# Performance Sheet

## SUBMITTAL DATA - I-P UNITS

Unit Designation: \_\_\_\_\_

Job Name: \_\_\_\_\_

Architect: \_\_\_\_\_

Engineer: \_\_\_\_\_

Contractor: \_\_\_\_\_

## PERFORMANCE DATA

Cooling Capacity: \_\_\_\_\_ Btuh

EER: \_\_\_\_\_

Heating Capacity: \_\_\_\_\_ Btuh

COP: \_\_\_\_\_

Ambient Air Temp: \_\_\_\_\_ °F

Entering Water Temp (Clg): \_\_\_\_\_ °F

Entering Air Temp (Clg): \_\_\_\_\_ °F

Entering Water Temp (Htg): \_\_\_\_\_ °F

Entering Air Temp (Htg): \_\_\_\_\_ °F

Airflow: \_\_\_\_\_ CFM

Fan Speed or Motor/RPM/Turns: \_\_\_\_\_

Operating Weight: \_\_\_\_\_ (lb)

## ELECTRICAL DATA

Power Supply: \_\_\_\_\_ Volts

\_\_\_\_\_ Phase \_\_\_\_\_ Hz

Minimum Circuit Ampacity: \_\_\_\_\_

Maximum Overcurrent Protection: \_\_\_\_\_

## SUBMITTAL DATA - S-I UNITS

Unit Designation: \_\_\_\_\_

Job Name: \_\_\_\_\_

Architect: \_\_\_\_\_

Engineer: \_\_\_\_\_

Contractor: \_\_\_\_\_

## PERFORMANCE DATA

Cooling Capacity: \_\_\_\_\_ kW

EER: \_\_\_\_\_

Heating Capacity: \_\_\_\_\_ kW

COP: \_\_\_\_\_

Ambient Air Temp: \_\_\_\_\_ °C

Entering Water Temp (Clg): \_\_\_\_\_ °C

Entering Air Temp (Clg): \_\_\_\_\_ °C

Entering Water Temp (Htg): \_\_\_\_\_ °C

Entering Air Temp (Htg): \_\_\_\_\_ °C

Airflow: \_\_\_\_\_ l/s

Fan Speed or Motor/RPM/Turns: \_\_\_\_\_

Operating Weight: \_\_\_\_\_ (kg)

## ELECTRICAL DATA

Power Supply: \_\_\_\_\_ Volts

\_\_\_\_\_ Phase \_\_\_\_\_ Hz

Minimum Circuit Ampacity: \_\_\_\_\_

Maximum Overcurrent Protection: \_\_\_\_\_

# Revision History

Date:	Item:	Action:
3/08/23	Pages 25, 99, and 104	Removed AHH hose kits. Updated the hose kit mechanical specs.
12/22/22	All	Transitioned CXM to CXM2 and DXM2 to DXM2.5 unit controls. Introduced AWC Wi-Fi communicating color touchscreen thermostat
06/14/22	Pages 9, 23	Added page to describe the CT ECM blower motor functionality. Updated ratings table.
03/24/22	Pages 65	Added additional cabinet dimensions
09/28/21	All	Removed LON Controls
09/07/21	Pages 57, 58 and 71	Added RA filter dimensions to physical data tables and updated AVHS "G" panel dimensions
08/26/21	Page 19, 71	Introduced ADA Type 1/Type 2 Thermostat Mounting Table in the AVHS "G" Panel Decoder
01/18/21	Page 20	Added Riser Decoder
01/08/21	Pages Added	Updated Physical Data, added Hybrid Physical Data and Supply Air Opening and Grilles pages, changed measurements on Hose Kits and Stands page
11/3/20	Page 84	Updated Engineering Specs
09/25/20	All	Updated document verbiage/layout, added Pre-Engineered section, introduced new 3-way water valve, risers attached with horizontal shipping, DDC chassis controls, thermostat options, new decoder format, and shipping tables
05/14/19	Pages 10,60,61,67	Misc. updates
01/11/19	Introduced Hybrid and E cabinet options	Added
09/26/18	All	updated heating LAT.
09/26/18	All	Reduced footprint of sizes 09-12. Introduced CT ECM w/CSM controls and added Flush Mounted Return Air Panel.
09/1/17	All	Updated decoder and DMX wiring diagrams
08/18/17	All	Updated information to new decoders
07/7/17	Cabinet and chassis decoders, 200 PSI pump, and modulating water valve, normally open MWV, and configuring cabinet.	Updated
05/08/17	Hose Kit Decoder and sweat valve	Updated
11/15/16	Document Design Update	Updated
04/19/16	Page 33	Updated
03/8/16	Page 62	Edit Engineering Specs
10/08/15	Performance Data - Page 12	Updated
09/01/15	Removed Electric Heat and vFlow Options	Updated
06/24/15	All	Updated
06/03/15	Engineering Specifications	Updated
1/14/15	All	Added vFlow, A Panel, ATP21W02, and Miscellaneous changes
12/16/14	Edits - Page 56	Updated
11/03/14	Misc Edits	Updated
06/30/14	Decoder	Updated
06/05/14	Created	



A NIBE GROUP MEMBER

7300 S.W. 44th Street  
Oklahoma City, OK 73179  
Phone: 405-745-6000  
climatemaster.com