

ROOFTOP (TRT) SERIES



COMMERCIAL ROOFTOP WATER-SOURCE HEAT PUMPS

INSTALLATION, OPERATION & MAINTENANCE

97B0138N01

Revised: November 5, 2024



A **NIBE** GROUP MEMBER

Table of Contents

Model Nomenclature	3
General Information	4
Dimensional Data	5
Standard Roof Curb	6
Installation	7
Piping Installation	8
Water Quality Requirements	9
Electrical – Wiring	13
Electrical – Low Voltage Wiring	14
Electrical – Thermostat Wiring	16
Sound Data	17
Electrical Data	18
Blower Motor VFD Controls	19
Wiring Diagram Matrix	21
Model Nomenclature – ClimaDry® II Option	22
ClimaDry® II – General Information	23
ClimaDry® II – Sequence of Operation	25
Blower Performance Data – Units with ClimaDry® II	27
Flushing/Purging Units with ClimaDry® II	28
Operating and Commissioning Limits	29
Start-Up Preparation	30
Blower Adjustment	31
Tensioning V-Belt Drives	32
Unit System Checkout	33
Unit Start-up	34
Operating Temperatures and Pressures	35
Start-up Log Sheet	36
Preventive Maintenance	37
Warranty	38
Revision History	40

Rooftop (TRT) Series

Rev.: November 5, 2024

This Page Intentionally Left Blank

Model Nomenclature

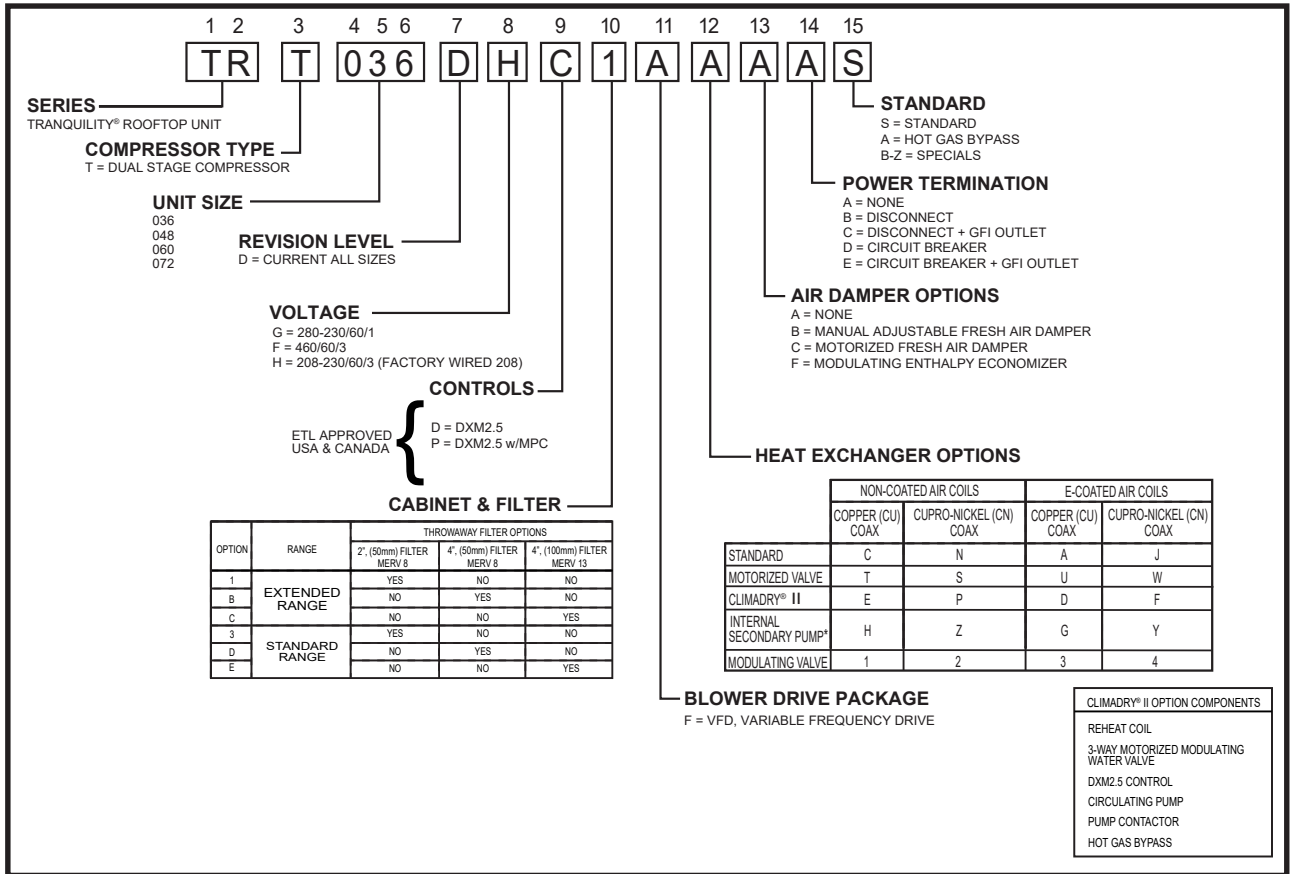

Curb (TRT & ERV Unit Nomenclature)

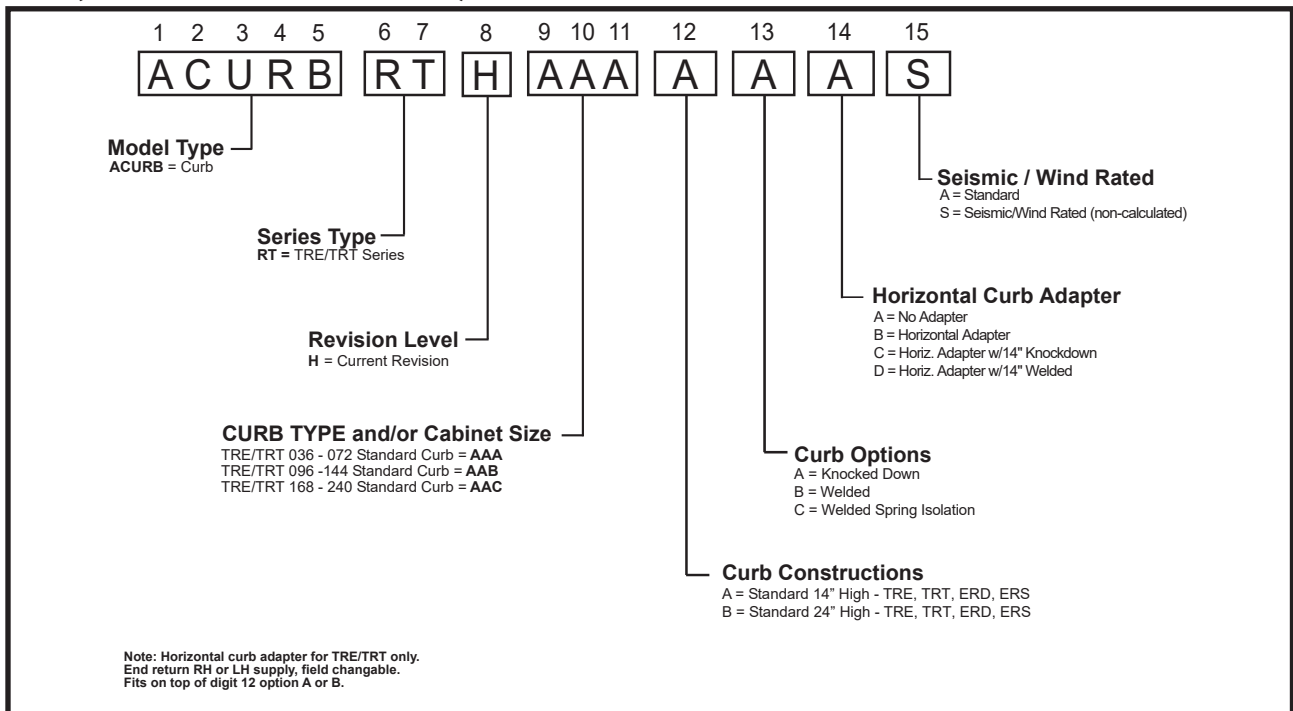

Rooftop (TRT) Series

Rev.: November 5, 2024

General Information

Inspection

Upon receipt of shipment at the job site, carefully check the shipment against the bill of lading. Make sure all units have been received. Inspect the carton or crating housing of each Rooftop Unit and inspect each unit for damage. Assure that the carrier makes proper notation of any shortages or damage on all copies of the freight bill and that he completes a Carrier Inspection Report. Concealed damage not discovered during unloading must be reported to the carrier within 15 days of receipt of shipment.

NOTE: It is the responsibility of the purchaser to file all necessary claims with the carrier.

Storage

Upon the arrival of equipment at the job site, immediately store units in a clean, dry area. **Store units in an upright position at all times.** TRT units should be stacked no more than 2 high. **Do not remove equipment from pallets until equipment is required for installation**

Unit Protection

Cover rooftop units on the job site. Cap the open ends of pipes. In areas where painting, plastering, roofing, or the spraying of fireproof material has not been completed, all due precautions must be taken to avoid physical damage to the units and contamination by foreign material.

Physical damage and contamination may prevent proper start-up and may result in costly equipment cleanup.

Pre-Installation

Installation, operation and maintenance instructions are provided with each unit. Before unit start-up, read all manuals and become familiar with the unit and its operation. Thoroughly check out the system before operation.

Prepare rooftop units for installation as follows:

1. Compare the electrical data on the unit nameplate with ordering and shipping information to verify that the correct unit has been shipped.
2. Select an installation site on the roof which allows adequate clearance for maintenance and servicing of the unit. A minimum of two feet of clearance is required on all service access and drain connection sides of the unit.
3. Verify that refrigerant tubing is free of kinks or dents, and that it has not been damaged during shipping.
4. Examine all pipes, fittings, valves and components before installing the system. Remove any dirt found on or in these components and assure that all components are securely fitted.
5. Verify curb is proper size for unit. Install curb according to manufacturer's instructions prior to installing unit.
6. Properly size supply and return duct work. Mount supply air duct to curb before installing unit.

CAUTION!

CAUTION! Supply air duct is inaccessible from inside unit once unit is installed.

WARNING!

WARNING! To avoid equipment damage, do not use these units as a source of heat during the construction process. The mechanical components and filters used in these units will quickly become clogged with construction dirt and debris which may cause system damage.

WARNING!

WARNING! Some units may be charged with refrigerants other than 410A and are so labeled. Use appropriate refrigerant handling techniques. Mixing refrigerants in units is dangerous and can cause equipment damage. To avoid the release of refrigerant into the atmosphere, the refrigerant circuit of this unit must only be serviced by technicians who meet local, state and federal proficiency requirements.

WARNING!

WARNING! The installation of water-source heat pumps and all associated components, parts, and accessories which make up the installation shall be in accordance with the regulations of ALL authorities having jurisdiction and MUST conform to all applicable codes. It is the responsibility of the installing contractor to determine and comply with ALL applicable codes and regulations.

Dimensional Data

Size	Outdoor Air Opening	Water In/Out (IPT)	Condensate
TRT036	12.57" x 30"	3/4"	1"
TRT048	12.57" x 30"	3/4"	1"
TRT060	12.57" x 30"	1"	1"
TRT072	12.57" x 30"	1-1/4"	1"

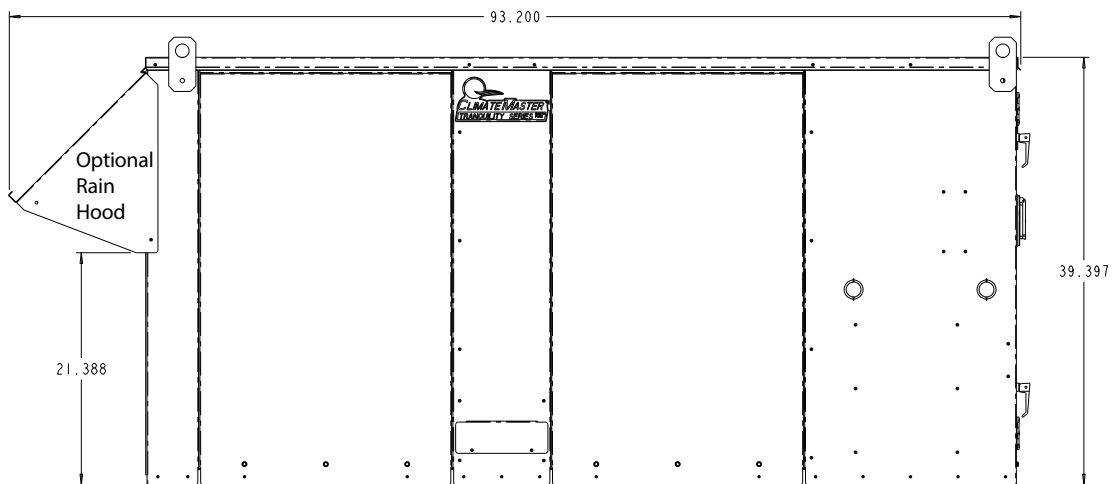
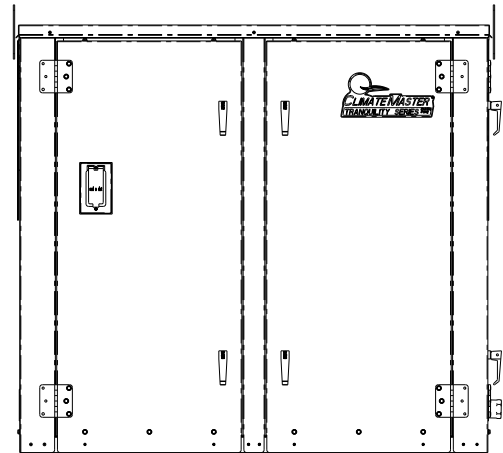
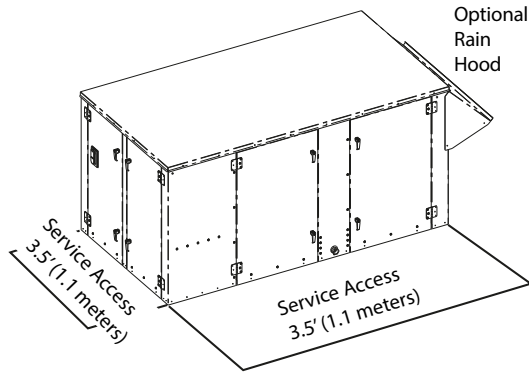

Top View of Base

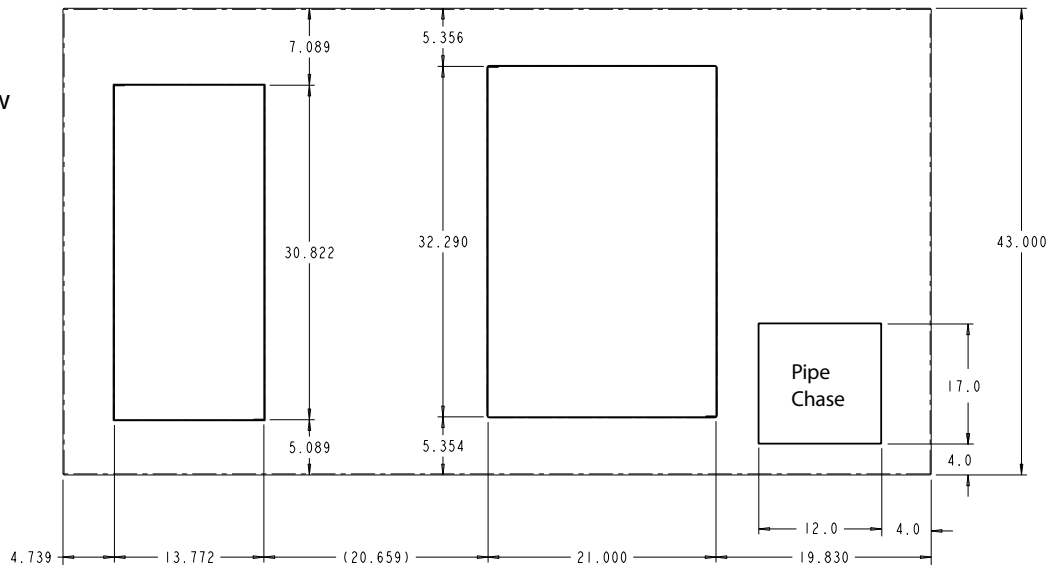

Rooftop (TRT) Series

Rev.: November 5, 2024

Standard Roof Curb

Model	A	B	C	D	E	F*
TRT036/48/60/72	72.25"	18"	35.25"	72.25"	35.25"	14" or 24"

* "F" dimension can be 14" or 24"

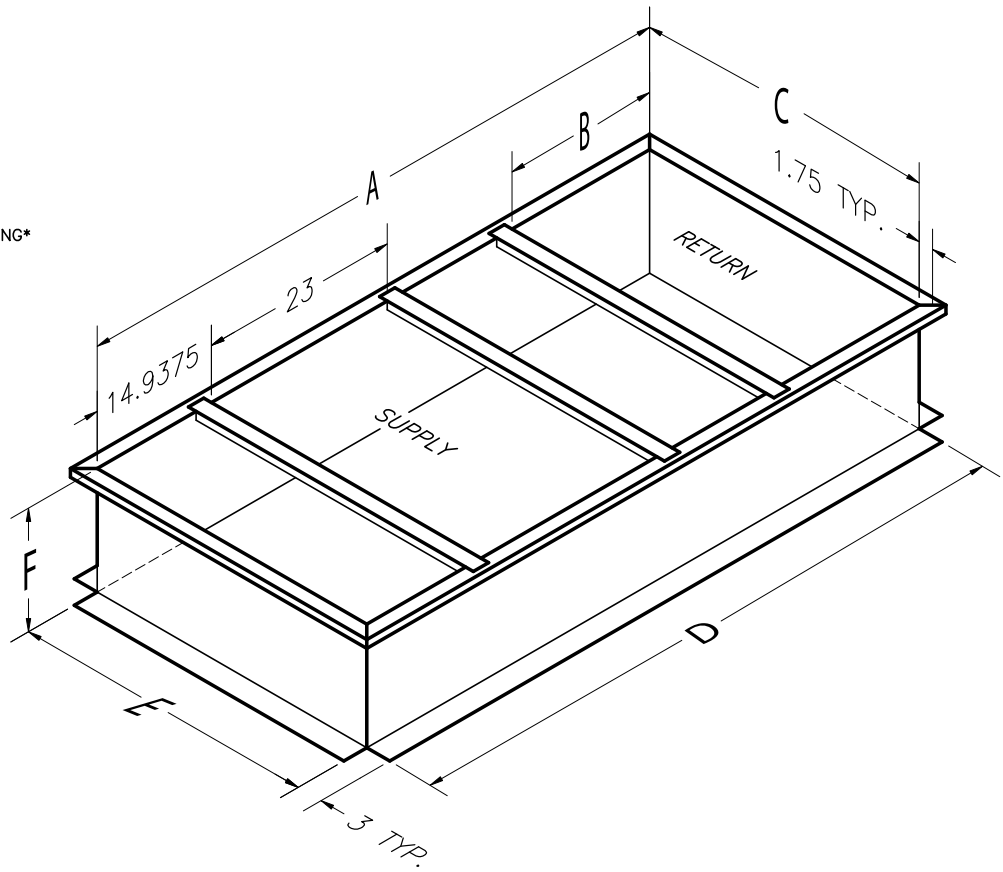
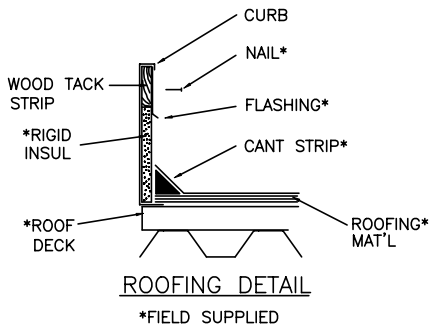

Installation

The installation of rooftop water-source heat pump units and all associated components, parts and accessories that make up the installation shall be in accordance with the regulations of ALL authorities having jurisdiction and MUST conform to all applicable codes. It is the responsibility of the Installing Contractor to determine and comply with ALL applicable codes and regulations.

⚠ CAUTION! ⚠

CAUTION! All refrigerant discharged from this unit must be recovered without exception. Technicians must follow industry accepted guidelines and all local, state and federal statutes for the recovery and disposal of refrigerants.

When a compressor is removed from this unit, system refrigerant circuit oil will remain in the compressor. To avoid leakage of compressor oil, the refrigerant lines of the compressor must be sealed after it is removed.

Mineral oil or equipment exposed to mineral oil (manifold gauges, vacuum pumps or hoses) cannot be used to service units charged with 410A refrigerant and P.O.E. oil. HFC-410A and P.O.E. oil are extremely hygroscopic (they absorb water from air). Only P.O.E. oil that has been verified as moisture free can be added to the system. Consult factory for more information.

Location, Access and Curb Installation

Install curbs with adequate clearance to allow unit maintenance and servicing. Conform to the following guidelines when selecting curb location.

1. Provide adequate clearance for filter replacement and drain pan removal. Do not block filter access with piping, conduit or other materials.
2. Provide access for fan and fan motor maintenance and for servicing the compressor and coils without removal of the unit.
3. Provide an unobstructed path to the unit to enable removal of the unit if necessary.
4. Provide access to water valves and fittings, and adequate access to the unit side panels and all electrical connections.

Follow these guidelines when installing the curb.

1. Set unit on curb.
2. Align unit so that return air and supply air in the unit match return and supply air opening in the curb frame.
3. Run supply and return loop piping and electrical supply lines through the pipe chase provided in the curb.

Figure 1: TRT Curb Installation

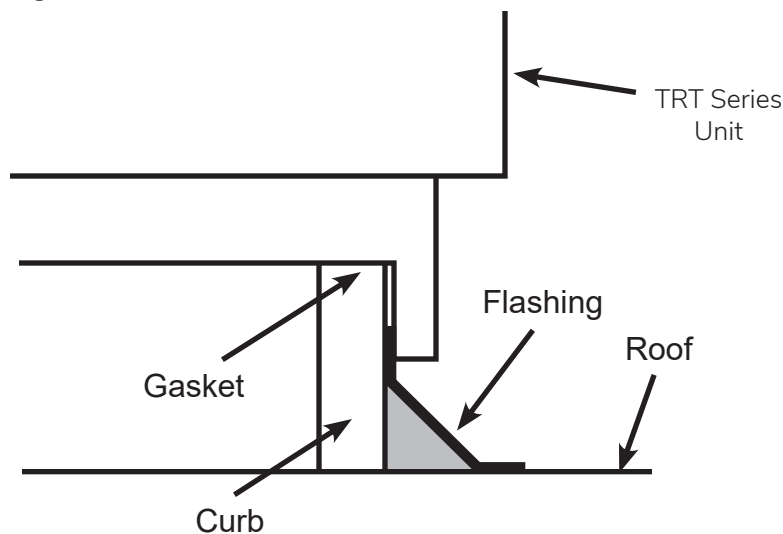

NOTE: Refer to previous pages for actual unit dimensions.

Rooftop (TRT) Series

Rev.: November 5, 2024

Piping Installation

! WARNING! !

WARNING! Piping must comply with all applicable Codes.

Supply and Return Piping

Follow these piping guidelines.

1. Install a drain valve at the base of each supply and return riser to facilitate system flushing.
2. Install shut-off/balancing valves and unions at each unit to permit unit removal of unit, if required.
3. Place strainers at the inlet of each system circulating pump. To ensure a clean system.

Always insulate where the piping runs through unheated areas or outside the building. If loop temperature is maintained between 60°F and 90°F, piping will not sweat nor lose heat under normal ambient conditions. Otherwise, insulation is required on loop water piping.

All loop piping above grade must be insulated on any unit connected to an open or closed GeoThermal loop (GLHP, GWHP).

Pipe joint compound is not necessary when Teflon® threaded tape is pre-applied to hose assemblies or when flared-end connections are used. If pipe joint compound is preferred, use compound only in small amounts on the male pipe threads of the fitting adapters. Prevent sealant from reaching the flared surfaces of the joint.

Maximum allowable torque for brass fittings is 30 foot-pounds. If a torque wrench is not available, tighten finger-tight plus one quarter turn. Tighten steel fittings as necessary.

NOTE: The manufacturer strongly recommends all piping connections, both internal and external to the unit, be pressure tested by an appropriate method prior to any finishing of the interior space or before access to all connections is limited. Test pressure may not exceed the maximum allowable pressure for the unit and all components within the water system. The manufacturer will not be responsible or liable for damages from water leaks due to inadequate or lack of a pressurized leak test, or damages caused by exceeding the maximum pressure rating during installation.

Condensate Piping

Install a condensate trap at each unit with the top of the trap positioned below the unit condensate drain connection.

Design the length of the trap (water-seal) based upon the amount of positive or negative pressure on the drain pan. As a general rule, 1" of trap is required for each 1" of negative pressure on the unit with a 1.5" (38 mm) minimum. Each unit must be installed with a dedicated trap for that unit.

Note that condensate may be allowed to drain onto the roof.

Figure 2 illustrates a typical trap used with TRT Heat Pumps.

Figure 2: Condensate Drain

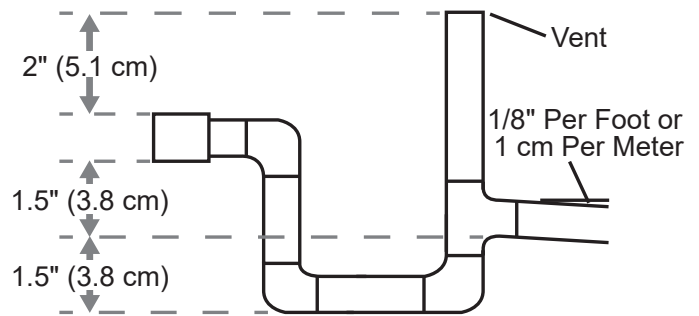

! WARNING! !

WARNING! Polyolester Oil, commonly known as POE oil, is a synthetic oil used in many refrigeration systems including those with HFC-410A refrigerant. POE oil, if it ever comes in contact with PVC or CPVC piping, may cause failure of the PVC/CPVC. PVC/CPVC piping should never be used as supply or return water piping with water source heat pump products containing HFC-410A as system failures and property damage may result.

! CAUTION! !

CAUTION! Corrosive system water requires corrosion-resistant fittings and hoses and may require water treatment.

Water Quality Requirements

Table 1: Water Quality Requirements

Clean water is essential to the performance and life span of water source heat pumps. Contaminants, chemicals, and minerals all have the potential to cause damage to the water heat exchanger if not treated properly. All closed water loop systems should undergo water quality testing and be maintained to the water quality requirements listed in this table.

WATER QUALITY REQUIREMENTS							
For Closed-Loop and Open-Loop Systems							
	Description	Symbol	Units	Heat Exchanger Type			
				Closed Loop Recirculating	Open Loop, Tower, Ground Source Well		
				All Heat Exchanger Types	COAXIAL HX Copper Tube in Tube	COAXIAL HX Cupronickel	Brazed Plate HX 316 SS
Scaling Potential	pH - Chilled Water <85°F			7.0 to 9.0	7.0 to 9.0	7.0 to 9.0	7.0 to 9.0
	pH - Heated Water >85°F			8.0 to 10.0	8.0 to 10.0	8.0 to 10.0	8.0 to 10.0
	Alkalinity	(HCO ₃ ⁻)	ppm - CaCO ₃ equiv.	50 to 500	50 to 500	50 to 500	50 to 500
	Calcium	(Ca)	ppm	<100	<100	<100	<100
	Magnesium	(Mg)	ppm	<100	<100	<100	<100
	Total Hardness	(CaCO ₃)	ppm - CaCO ₃ equiv.	30 to 150	150 to 450	150 to 450	150 to 450
	Langelier Saturation Index	LSI		-0.5 to +0.5	-0.5 to +0.5	-0.5 to +0.5	-0.5 to +0.5
Ryznar Stability Index	RSI		6.5 to 8.0	6.5 to 8.0	6.5 to 8.0	6.5 to 8.0	
Corrosion Prevention	Total Dissolved Solids	(TDS)	ppm - CaCO ₃ equiv.	<1000	<1000	<1000	<1500
	Sulfate	(SO ₄ ²⁻)	ppm	<200	<200	<200	<200
	Nitrate	(NO ₃ ⁻)	ppm	<100	<100	<100	<100
	Chlorine (free)	(Cl)	ppm	<0.5	<0.5	<0.5	<0.5
	Chloride (water < 80°F)	(Cl ⁻)	ppm	<20	<20	<150	<150
	Chloride (water > 120°F)	(Cl ⁻)	ppm	<20	<20	<125	<125
	Hydrogen Sulfide ^a	(H ₂ S)	ppb	<0.5	<0.5	<0.5	<0.5
	Carbon Dioxide	(CO ₂)	ppm	0	<50	10 to 50	10 to 50
	Iron Oxide	(Fe)	ppm	<1.0	<1.0	<1.0	<0.2
	Manganese	(Mn)	ppm	< 0.4	<0.4	<0.4	<0.4
	Ammonia	(NH ₃)	ppm	<0.05	<0.1	<0.1	<0.1
	Chloramine	(NH ₂ CL)	ppm	0	0	0	0
Fouling & Biological	Iron Bacteria		cells/mL	0	0	0	0
	Slime Forming Bacteria		cells/mL	0	0	0	0
	Sulfate reducing bacteria		cells/mL	0	0	0	0
	Suspended Solids ^b	(TSS)	ppm	<10	<10	<10	<10
Electrolysis All HX types	Earth Ground Resistance ^x		Ohms	0	Consult NEC & local electrical codes for grounding requirements		
	Electrolysis Voltage ^δ		mV	<300	Measure voltage internal water loop to HP ground		
	Leakage Current ^δ		mA	<15	Measure current in water loop pipe		
	Building Primary Electrical Ground to unit, must meet local diameter and penetration length requirements Do not connect heat pump to steel pipe unless dissimilar materials are separated by using Di-electric unions. Galvanic corrosion of heat pump water pipe will occur.						

Rooftop (TRT) Series

Rev.: November 5, 2024

Water Quality Requirements, Cont'd.

1. The ClimateMaster Water Quality Table provides water quality requirements for coaxial & brazed plate heat exchangers.
 2. The water must be evaluated by an independent testing facility comparing site samples against this Table. When water properties are outside of these parameters, the water must either be treated by a professional water treatment specialist to bring the water quality within the boundaries of this specification, or an external secondary heat exchanger must be used to isolate the heat pump water system from the unsuitable water. Failure to do so will void the warranty of the heat pump system and will limit liability for damage caused by leaks or system failure.
 3. Regular sampling, testing and treatment of the water is necessary to assure that the water quality remains within acceptable levels thereby allowing the heat pump to operate at optimum levels.
 4. If closed-loop systems are turned off for extended periods, water samples must be tested prior to operating the system.
 5. For optimal performance, it is recommended that the closed-loop piping systems are initially filled with de-ionized water.
 6. Well water with chemistry outside of these boundaries, and salt water or brackish water requires an external secondary heat exchanger. Surface/Pond water should not be used.
 7. If water temperature is expected to fall below 40°F, antifreeze is required. Refer to the heat pump IOM for the correct solution ratios to prevent freezing.
- α Hydrogen Sulfide has an odor of rotten eggs. If one detects this smell, a test for H2S must be performed. If H2S is detected above the limit indicated, remediation is necessary (Consult with your Water Testing/Treatment Professional) or a secondary heat exchanger is required using appropriate materials as recommended by the heat exchanger supplier.
 - β Suspended solids and particulates must be filtered to prevent fouling and failure of heat exchangers. Strainers or particulate filters must be installed to provide a maximum particle size of 600 micron (0.60 mm, 0.023 in.) using a 20 to 30 mesh screen size. When a loop is installed in areas with fine material such as sand or clay, further filtration is required to a maximum of 100 micron. Refer to the Strainer / Filter Sizing Chart to capture the particle sizes encountered on the site.
 - χ An electrical grounding system using a dedicated ground rod meeting NEC and Local Electrical codes must be installed. Building Ground must not be connected the WSHP piping system or other plumbing pipes.
 - δ Refer to IOM for instructions on measuring resistance and leakage currents within water loops.

Do not use PVC pipe for water loop (compressor POE oil and glycols damage PVC) use of HDPE pipe is recommended.

Strainer / Filter Sizing			
Mesh Size	Particle Size		
	Microns	MM	Inch
20	840	0.840	0.0340
30	533	0.533	0.0210
60	250	0.250	0.0100
100	149	0.149	0.0060
150	100	0.100	0.0040
200	74	0.074	0.0029

ppm = parts per million
ppb = parts per billion

Water Quality Requirements, Cont'd.

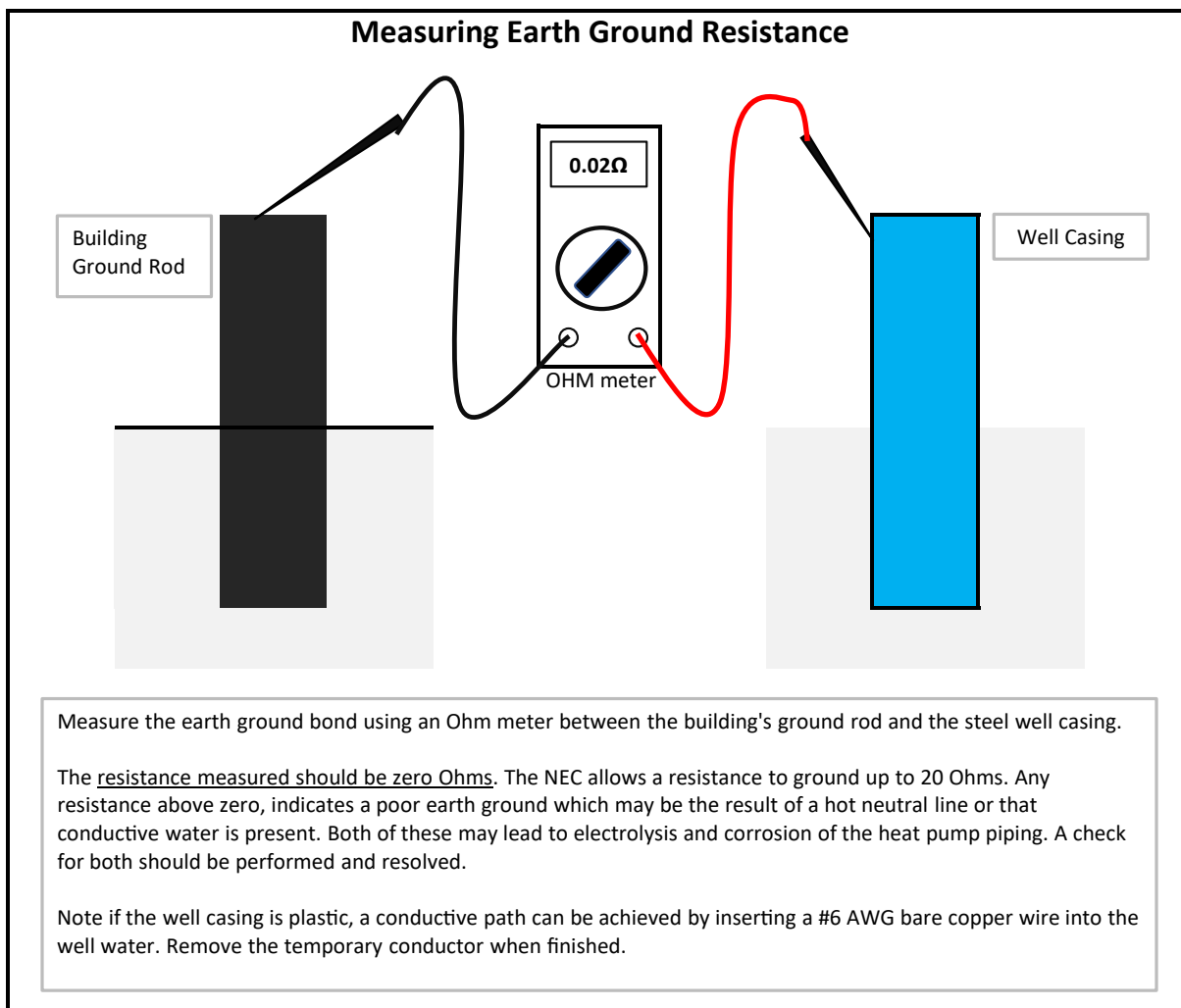

Rooftop (TRT) Series

Rev.: November 5, 2024

Water Quality Requirements, Cont'd.

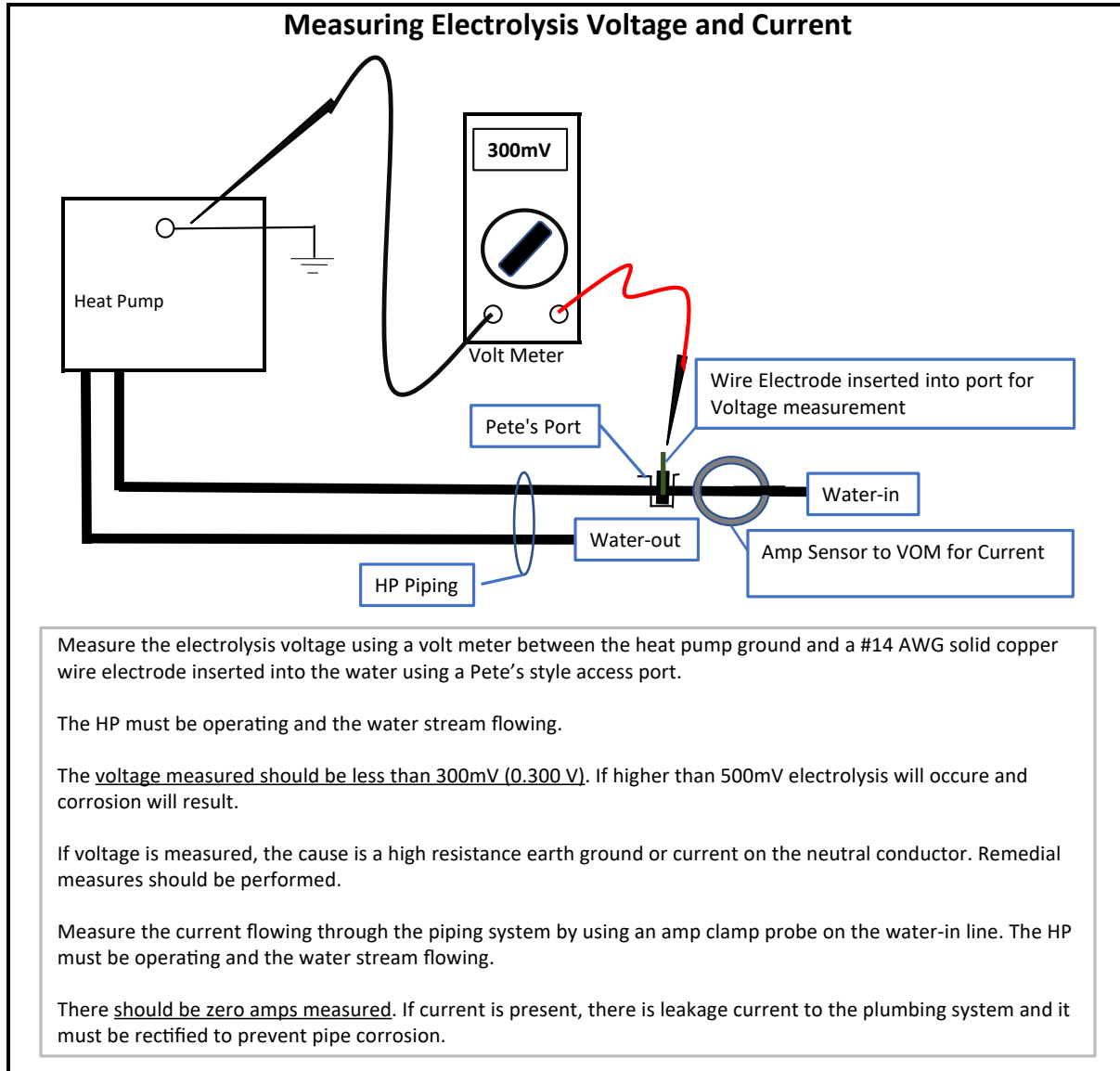

Electrical – Wiring

WARNING!

WARNING! Disconnect electrical power source to prevent injury or death from electrical shock.

General Line Voltage Wiring

Be sure the available power is the same voltage and phase as that shown on the unit serial plate. Line and low voltage wiring must be done in accordance with local codes or the National Electric Code, whichever is applicable.

TRT Power Connection

Line voltage connection is made by connecting the incoming line voltage wires to the power block. Line voltage conduit should be routed through curb and unit pipe chase. Terminate conduit at control/compressor deck.

208 Volt Operation

All 208-240 Volt units are factory wired for 208 Volt. The transformers may be switched to 240V operation as illustrated on the wiring diagram by switching the Red (240V) and the Orange (208V) wires on the transformer primary side. Unused wire terminal will be “hot” and must be insulated and secured to prevent an electric short.

CAUTION!

CAUTION! Use only copper conductors for field installed electrical wiring. Unit terminals are not designed to accept other types of conductors.

Optional GFI Outlet requires dedicated 115V - 20 AMP circuit provided by installer

Thermostat Wiring

All wiring must comply with all applicable electrical codes including NEC and local codes. Complete all wiring before units are installed. Use multi conductor, color-coded, low-voltage cable for all wiring. Refer to unit wiring diagram for required thermostat connections.

CAUTION!

CAUTION! Maintain zone integrity to assure accurate and efficient operational control of units or groups of units. Without adequate zone control, adjacent units may operate in heating and cooling mode simultaneously.

Refer to Table 2 for wire sizes and lengths. Do not allow the total resistance of all low-voltage wires used to exceed 1 ohm. Resistance in excess of 1 ohm may cause high voltage drop which may result in control malfunction.

Refer to the thermostat installation and operation manual to determine recommended heat anticipator settings.

When using a DDC building management system (BMS), communication grade wire may be required. Verify required communication and sensor wiring type with the manufacturer of the BMS system components.

Table 2: Recommended Thermostat Wire Sizes

WIRE SIZE	MAX. WIRE LENGTH*
22 - Gauge	30 feet [9.14 m]
20 - Gauge	50 feet [15.24 m]
18 - Gauge	75 feet [22.86 m]
16 - Gauge	125 feet [38.1 m]
14 - Gauge	200 feet [60.96 m]

* Length = physical length of wire from thermostat to unit.

Rooftop (TRT) Series

Rev.: November 5, 2024

Electrical – Low Voltage Wiring

Thermostat Connections

The thermostat will be wired to the DXM2.5 board located within the unit control box. Refer to the unit wiring diagram for specific details.

Low Water Temperature Cutout Selection

The DXM2.5 control allows the field selection of low water (or water-antifreeze solution) temperature limit by clipping jumper JW3, which changes the sensing temperature associated with thermistor LT1. Note that the LT1 thermistor is located on the refrigerant line between the coaxial heat exchanger and expansion device (TXV). Therefore, LT1 is sensing refrigerant temperature, not water temperature, which is a better indication of how water flow rate/temperature is affecting the refrigeration circuit.

The factory setting for LT1 is for systems using water (30°F [-1.1°C] refrigerant temperature). In low water temperature (extended range) applications with antifreeze (most ground loops), jumper JW3 should be clipped as shown in Figure 3 to change the setting to 10°F [-12.2°C] refrigerant temperature, a more suitable temperature when using an antifreeze solution. All ClimateMaster units operating with entering water temperatures below 60°F [15.6°C] must include the optional water/refrigerant circuit insulation package to prevent internal condensation.

Figure 3: LT1 Limit Setting

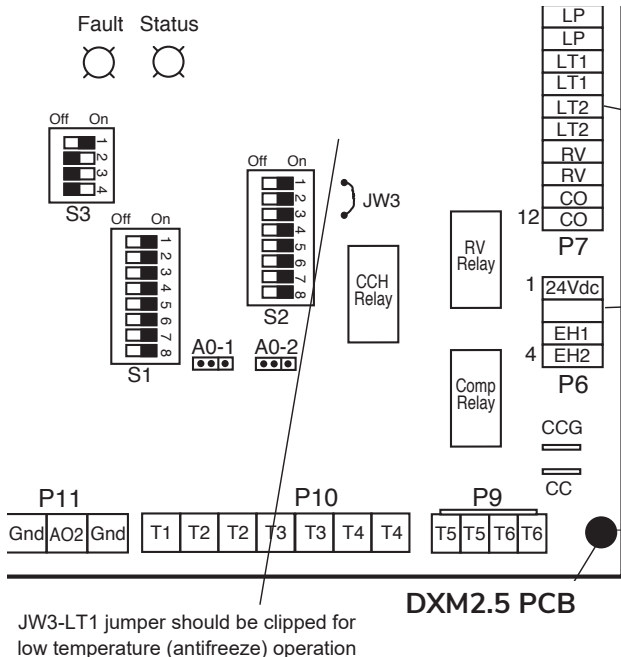

Accessory Connections

A terminal paralleling the compressor contactor coil has been provided on the DXM2.5 control. Terminal “A” is designed to control accessory devices. **NOTE: This terminal should be used only with 24 Volt signals and not line voltage. Terminal “A” is energized with the compressor contactor.**

The DXM2.5 controller includes two accessory relays ACC1 and ACC2. Each relay includes a normally open (NO) and a normally closed (NC) contact. Accessory relays may be configured to operate as shown in the tables below.

Accessory Relay 1 Configuration

DIP 2.1	DIP 2.2	DIP 2.3	ACC1 Relay Option
ON	ON	ON	Cycle with fan
OFF	ON	ON	N/A for Residential Applications
ON	OFF	ON	Water valve – Slow opening
ON	ON	OFF	Outside air damper
OFF	ON	OFF	ClimaDry® II option – Dehumidistat
OFF	OFF	OFF	ClimaDry® II option – Humidistat
OFF	OFF	ON	N/A for Residential Applications
ON	OFF	OFF	N/A for Residential Applications

All other DIP combinations are invalid

Accessory Relay 2 Configuration

DIP 2.4	DIP 2.5	DIP 2.6	ACC2 Relay Option
ON	ON	ON	Cycle with compressor
OFF	ON	ON	N/A for Residential Applications
ON	OFF	ON	Water valve – Slow opening
OFF	OFF	ON	Humidifier
ON	ON	OFF	Outside air damper

All other DIP combinations are invalid

Electrical – Low Voltage Wiring, Cont'd.

Figure 4: Accessory Wiring

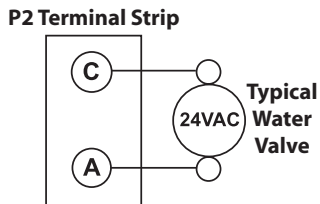

A slow closing valve may be required to help reduce water hammer. Figure 4 shows typical wiring for a 24VAC external solenoid valve. Figures 5 and 7 illustrate typical slow closing water control valve wiring for Taco 500 series (ClimateMaster P/N AVM) and Taco SBV series valves. Slow closing valves take approximately 60 seconds to open (very little water will flow before 45 seconds). Once fully open, an end switch allows the compressor to be energized. Only relay or triac based electronic thermostats should be used with slow closing valves. When wired as shown, the slow closing valve will operate properly with the following notations:

1. The valve will remain open during a unit lockout.
2. The valve will draw approximately 25-35 VA through the "Y" signal of the thermostat.

NOTE: This valve can overheat the anticipator of an electromechanical thermostat. Therefore, only relay or triac based thermostats should be used.

FOR NON-vFLOW® UNITS USING EXTERNAL MOTORIZED WATER VALVE

Figure 5: Accessory Motorized Water Valve - Typical Wiring Example #1

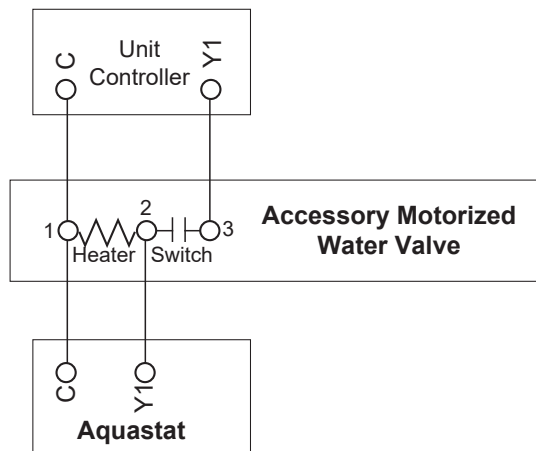

Figure 6: Two-Stage Piping

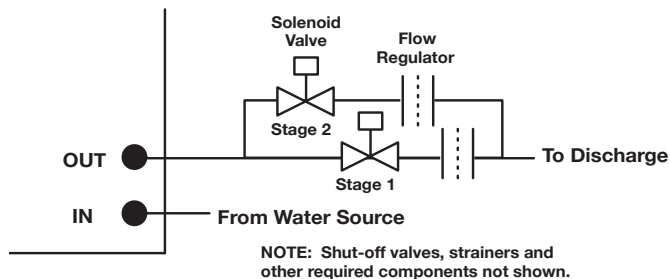
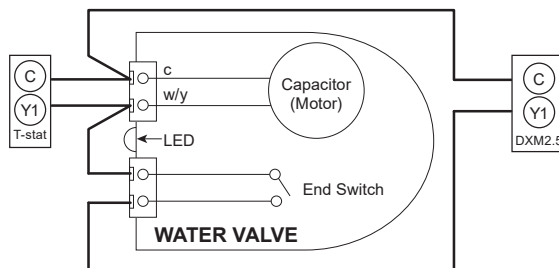

Figure 7: Accessory Motorized Water Valve - Typical Wiring Example #2



Rooftop (TRT) Series

Rev.: November 5, 2024

Electrical – Thermostat Wiring

Thermostat Installation - The thermostat should be located on an interior wall in a larger room, away from supply duct drafts. DO NOT locate the thermostat in areas subject to sunlight, drafts or on external walls. The wire access hole behind the thermostat may in certain cases need to be sealed to prevent erroneous temperature measurement. Position the thermostat back plate against the wall so that it appears level and so the thermostat wires protrude through the middle of the back plate. Mark the position of the back plate mounting holes and drill holes with a 3/16 inches (5 mm) bit. Install supplied anchors and secure plate to the wall. Thermostat wire must be 18 AWG wire. Representative thermostat wiring is shown in Figures 8a-b however, actual wiring connections should be determined from the thermostat IOM and or unit wiring diagram. Practically any heat pump thermostat will work with ClimateMaster units, provided it has the correct number of heating and cooling stages.

Figure 8a: Conventional 3 Heat / 2 Cool Thermostat Connection to DXM2.5 Control

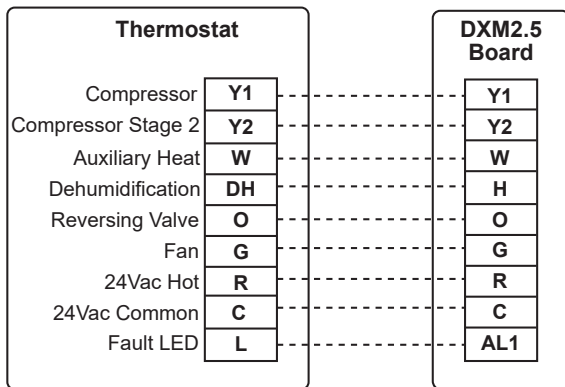
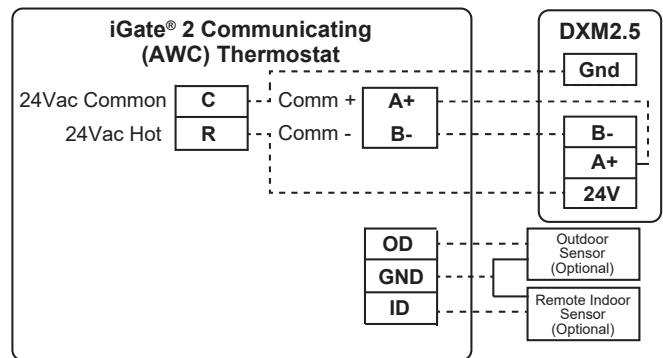
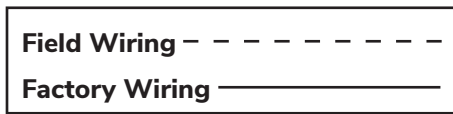

Figure 8b: Communicating Thermostat Connection to DXM2.5 Control



NOTES:

- 1) ECM automatic dehumidification mode operates with dehumidification airflows in the cooling mode when the dehumidification output from thermostat is active. Normal heating and cooling airflows are not affected.
- 2) DXM2.5 board DIP switch S2-7 must be in the auto dehumidification mode for automatic dehumidification.
- 3) DH connection not possible with units with internal variable speed pump. Use iGate® 2 Communicating (AWC) Thermostat.
- 4) Only use iGate® 2 Communicating (AWC) Thermostat when using Humidifier (H Input) in units with internal variable speed pump.



Sound Data

Standard 60 Hz Construction – Belt Drive Blower Motor + VFD

Model	Mode	Ducted Discharge Octave Band Frequency, Hz.							Free Air Inlet Combined With Casing (Cabinet) Radiated, Octave Band Frequency, Hz.						
		125	250	500	1000	2000	4000	8000	125	250	500	1000	2000	4000	8000
TRT036	Fan Only	55	50	37	33	34	36	34	64	51	48	48	41	47	40
	Cooling: Full Load	61	52	47	47	45	42	38	75	64	58	54	54	54	45
	Heating: Full Load	61	52	47	47	45	40	37	75	63	58	55	52	50	47
	Cooling: Part Load	53	49	34	34	37	38	36	69	65	55	58	57	54	43
	Heating: Part Load	53	46	36	32	30	33	35	69	65	56	53	48	46	44
TRT048	Fan Only	49	41	35	31	28	33	36	61	52	49	45	42	48	42
	Cooling: Full Load	59	54	50	47	48	47	42	72	65	62	59	55	56	49
	Heating: Full Load	59	53	49	47	46	44	40	72	63	60	56	53	55	48
	Cooling: Part Load	52	43	37	33	31	33	35	67	64	57	54	50	49	43
	Heating: Part Load	54	44	37	32	28	32	36	67	59	54	46	43	48	41
TRT060	Fan Only	51	40	33	32	31	34	35	60	53	50	53	46	46	40
	Cooling: Full Load	60	52	46	40	40	43	38	69	62	58	57	54	54	46
	Heating: Full Load	60	51	44	41	40	42	37	69	63	62	57	54	52	45
	Cooling: Part Load	52	43	34	33	33	35	35	63	59	53	52	46	47	42
	Heating: Part Load	53	44	32	31	30	33	35	63	61	55	52	45	46	42
TRT072	Fan Only	52	40	36	31	30	34	36	62	54	51	50	44	48	42
	Cooling: Full Load	64	54	52	46	47	49	49	72	65	68	60	58	61	53
	Heating: Full Load	64	54	50	46	46	48	41	72	64	64	60	57	60	51
	Cooling: Part Load	53	42	37	31	31	35	35	65	60	56	56	49	53	50
	Heating: Part Load	53	40	37	31	30	34	36	65	64	55	56	49	52	49

Tested in accordance with ARI 260
 TRT comes standard w/mute construction
 TRT Series Octave Band Sound Power Level (dB re 1PW)

Rooftop (TRT) Series

Rev.: November 5, 2024

Electrical Data

Electrical Data – Standard

Model #	Voltage Code	Voltage	Min/Max Voltage	Blower Option	Compressor			Blower Motor VFD			Rated Current *	Min Circuit Amp	SCCR kA rms Symmetrical	SCCR Volts Maximum	Max Fuse/HACR
					QTY	RLA	LRA	QTY	FLA	HP					
TRT036	G	208-1-60	197/254	VFD Only	1	15.6	83.0	1	11.4	1.0	27.0	30.9	5	600	45
	H	208-3-60	197/254	VFD Only	1	11.6	73.0	1	8.4	1.0	20.0	22.9	5	600	30
	F	460-3-60	414/506	VFD Only	1	5.7	38.0	1	4.1	1.0	9.8	11.2	5	600	15
TRT048	G	208-1-60	197/254	VFD Only	1	21.2	104.0	1	16.1	1.5	37.3	42.6	5	600	60
	H	208-3-60	197/254	VFD Only	1	14.0	83.1	1	13.0	1.5	27.0	30.5	5	600	40
	F	460-3-60	414/506	VFD Only	1	6.4	41.0	1	6.0	1.5	12.4	14.0	5	600	20
TRT060	G	208-1-60	197/254	VFD Only	1	26.9	139.9	1	16.1	1.5	43.0	49.7	5	600	70
	H	208-3-60	197/254	VFD Only	1	16.5	110.0	1	13.0	1.5	29.5	33.6	5	600	50
	F	460-3-60	414/506	VFD Only	1	7.2	52.0	1	6.0	1.5	13.2	15.0	5	600	20
TRT072	G	208-1-60	197/254	VFD Only	1	29.7	179.2	1	16.8	2.0	46.5	53.9	5	600	80
	H	208-3-60	197/254	VFD Only	1	17.6	136.0	1	13.2	2.0	30.8	35.2	5	600	50
	F	460-3-60	414/506	VFD Only	1	8.5	66.1	1	6.9	2.0	15.4	17.5	5	600	25

* Verbiage change from Total FLA to Rated Current

Electrical Data – ClimaDry® II Reheat or Internal Secondary Pump

Model #	Voltage Code	Voltage	Min/Max Voltage	Blower Option	Compressor			Blower Motor VFD			Pump		Rated Current *	Min Circuit Amp	SCCR kA rms Symmetrical	SCCR Volts Maximum	Max Fuse/HACR
					QTY	RLA	LRA	QTY	FLA	HP	QTY	FLA					
TRT036	G	208-3-60	197/254	VFD Only	1	15.6	83.0	1	11.4	1.0	1	1.07	28.1	32.0	5	600	45
	H	208-3-60	197/254	VFD Only	1	11.6	73.0	1	8.4	1.0	1	1.07	21.1	24.0	5	600	35
	F	460-3-60	414/506	VFD Only	1	5.7	38.0	1	4.1	1.0	1	1.07	10.9	12.3	5	600	15
TRT048	G	208-3-60	197/254	VFD Only	1	21.2	104.0	1	16.1	1.5	1	1.07	38.4	43.7	5	600	60
	H	208-3-60	197/254	VFD Only	1	14.0	83.1	1	13.0	1.5	1	1.07	28.1	31.6	5	600	45
	F	460-3-60	414/506	VFD Only	1	6.4	41.0	1	6.0	1.5	1	1.07	13.5	15.1	5	600	20
TRT060	G	208-3-60	197/254	VFD Only	1	26.9	139.9	1	16.1	1.5	1	1.07	44.1	50.8	5	600	70
	H	208-3-60	197/254	VFD Only	1	16.5	110.0	1	13.0	1.5	1	1.07	30.6	34.7	5	600	50
	F	460-3-60	414/506	VFD Only	1	7.2	52.0	1	6.0	1.5	1	1.07	14.3	16.1	5	600	20
TRT072	G	208-3-60	197/254	VFD Only	1	29.7	179.2	1	16.8	2.0	1	1.07	47.6	55.0	5	600	80
	H	208-3-60	197/254	VFD Only	1	17.6	136.0	1	13.2	2.0	1	1.07	31.9	36.3	5	600	50
	F	460-3-60	414/506	VFD Only	1	8.5	66.1	1	6.9	2.0	1	1.07	16.5	18.6	5	600	25

* Verbiage change from Total FLA to Rated Current

Blower Motor Variable Frequency Drive (VFD) Controls

VFD Blower Description

Variable Frequency Drives are controllers that vary electrical frequency and voltage to the fan motor. Electrical frequency is directly related to a fan motor's speed (RPM's). The faster the frequency, the faster the motor will go and vice versa. VFD's allow the fan motor to ramp speed (CFM) up or down to match the load of the space they are satisfying. This allows the TRT product to deliver variable capacity, optimizing system efficiency and saving owners money.

VFD controllers come factory installed and tested to provide supply fan motor speed modulation. VFDs on the supply fan, are quieter, more efficient, and are eligible for utility rebates. These products are commonly used in single zone variable air volume (VAV) applications. When applied to single zone VAV applications the system modulates the indoor fan and stages the compressor as space temperature changes, for increased part-load efficiency and more precise temperature control with fan speed varying down to 60% of maximum air flow. The VFD controls are paired with our intelligent DXM2.5 controls to provide superior service and functionality.

VFD Blower Sequence of Operation

The VFD blower option comes factory programmed with DXM2.5 controls. The DXM2.5 controls the VFD blower controller using a 0–10 VDC control signal, and comes factory programmed for Leaving Air Temperature (LAT) control mode. When the VFD is off, the output should be set to 0 VDC. For each unit size, there will be a maximum and minimum operating speed that the VFD can be operated at for any mode, defined in VFD Operational Table 3.1.

The VFD blower may be operated in LAT or discrete speed control modes.

NOTE: VFD output is 50% of last value during heating or cooling blower off delay times.

LAT Control VFD Operation

The DXM2.5 will come factory configured for LAT control operation. The VFD speed will be controlled by the DXM2.5 to maintain the factory default LAT set point, 55°F for cooling and 105°F for heating. LAT can be adjusted in the field. See VFD Operational Table 3.1 for full details.

When a compressor demand is recognized, the VFD output will be set to the most recent operating speed of the VFD in the current operating mode (heating or cooling). If there is no value stored from a previous heating or cooling cycle, the VFD speed will initially set at 75% or 8.0 VDC. After the VFD speed is initially set, the VFD control signal will not be adjusted until after 90 seconds of compressor operation, and then will be periodically checked and adjusted every 10 seconds if needed to maintain the LAT.

If the control switches from the heating mode to cooling, or cooling to heating without de-activating the compressor, the VFD control voltage will immediately switch to the last stored control voltage for the new operating mode, and then will not be adjusted for the first 90 seconds of operation in the new operating mode.

The VFD control voltage is increased or decreased incrementally based on the magnitude of the differential between the current LAT and the target LAT defined in VFD Operational Table 3.2.

Discrete Speed VFD Operation

When the DXM2.5 is configured for discrete speed VFD operation, the VFD speed will be set to the selected operating speed (A, B or C) for full load heating or cooling. Full load operation is defined as second stage or higher heating or cooling.

When the DXM2.5 is configured for discrete speed VFD operation, the VFD operating speed may be increased or decreased by 10%, if the appropriate speed adjustment flag is set in the VFD configuration flags. If the increase and decrease flags are both set, there will be no adjustment from the normal value.

When operating in first stage heating or cooling, the VFD speed will be set to the percentage of the selected full load operating speed (A, B or C, plus or minus adjustment) listed for each unit size as defined in VFD Operational Table 3.3.

Rooftop (TRT) Series

Rev.: November 5, 2024

Blower Motor Variable Frequency Drive (VFD) Controls, Cont'd.

VFD Operational Table 3.1

HP Family	Unit Size	Minimum Heat LAT	Maximum Heat LAT	Default Heat LAT	Minimum Cool LAT	Maximum Cool LAT	Default Cool LAT
TRT	36	85°	125°	105°	45°	65°	55°
	48	85°	125°	105°	45°	65°	55°
	60	85°	125°	105°	45°	65°	55°
	72	85°	125°	105°	45°	65°	55°

VFD Operational Table 3.2

LAT differential Actual – Target	VFD adjust (VDC)
$\Delta T \leq 1.0^{\circ}\text{F}$	0.0
$1.0 < \Delta T \leq 2.0^{\circ}\text{F}$	0.1
$2.0 < \Delta T \leq 3.0^{\circ}\text{F}$	0.2
$3.0 < \Delta T \leq 5.0^{\circ}\text{F}$	0.3
$\Delta T > 5.0^{\circ}\text{F}$	0.4

VFD Operational Table 3.3

HP Family	Unit Size	Minimum VFD Speed	Maximum VFD Speed	VFD Fixed Speed A	VFD Fixed Speed B	VFD Fixed Speed C	Part Load Multiplier	Default Fan Speed
TRT	36	3.6	9.9	6.9	5.8	8.9	75%	4.8
	48	4.5	9.5	7.5	7	8.5	75%	6
	60	4.3	9.8	7.3	6.7	8.8	75%	5.7
	72	3.9	9.9	7.2	6.2	8.9	75%	5.2

NOTE: All speed values are voltages from 0-10VDC

Wiring Diagram Matrix

All current diagrams can be located online at climatemaster.com.
Click 'Commercial Professional'.

1. Click 'Products' in the main navigation
2. Select 'Rooftop: Water Cooled'
3. Select the TRT product series
4. Click the Wire Diagrams tab in the middle of the page
5. Select your voltage and controls

Base unit Diagram	Voltage	TRT036-072
w/ DXM2.5 No Outside/Air	G = 208-230/60/1	96B0254N01
w/ DXM2.5 MTRZD Damper		
w/ DXM2.5 No Outside/Air	F = 460/60/3 H = 208-230/60/3	96B0254N03
w/ DXM2.5 MTRZD Damper		

*Option Diagram	
w/ MPC DDC	96B0291N03
w/Economizer	96B0291N02

Motorized valve and Internal Secondary Pump Options are included on the DXM2.5 base diagrams for non-ClimaDry® II applications.
Motorized outside air damper option is shown on the base unit diagrams.
Units with MPC or Economizer options will have multiple diagrams.

Rooftop (TRT) Series

Rev.: November 5, 2024

Model Nomenclature – ClimaDry® II Option

1	2	3	4	5	6	7	8	9	10	11	12	13	14	15
TRT	0	3	6	D	H	C	1	A	E	A	A	S		

HEAT EXCHANGER OPTIONS ③ ⑥ ⑦ ⑧

	NON-COATED AIR COILS		COATED AIR COILS	
	COPPER (CU) COAX	CUPRO-NICKEL (CN) COAX	COPPER (CU) COAX	CUPRO-NICKEL (CN) COAX
STANDARD	C	N	A	J
MOTORIZED VALVE	T	S	U	W
CLIMADRY® II	E	P	D	F
INTERNAL SECONDARY PUMP	H	Z	G	Y

CLIMADRY® II OPTION COMPONENTS
REHEAT COIL
3-WAY MOTORIZED MODULATING WATER VALVE
DXM2.5 CONTROL
CIRCULATING PUMP
PUMP CONTACTOR
HOT GAS BYPASS

NOTES:

1. ClimaDry® II reheat option (Digit 12 - D, E, F or P) must be ordered with original equipment (cannot be field added). Unit must have DXM2.5 control. 460 volts require 4 wire power supply with neutral. Not available for units with internal water valve, flow regulator options, or 575Volt. Check unit submittal for limitations and specific requirements.
2. All TRT rooftops with the ClimaDry II reheat option require antifreeze to protect the reheat coil in low ambient conditions. ASHRAE minimums for the region shall be considered during the calculation of the antifreeze solution.
3. ClimaDry II is not recommended for applications with poor water quality (see water quality guidelines in unit IOM). The copper heat exchanger (Digit 12 - D or E) with cast iron pump are designed for closed loop systems.
4. Max working water pressure for the ClimaDry II option is 145 psig.
5. Thermostat must be either:
 - A. Thermostat with dehumidification mode (ATP32U04 or similar)
 - B. Thermostat and separate humidistat or dehumidistat controller (see Table 4 for DXM2.5 DIP settings).
6. ClimaDry II units must have minimum entering air temperature of 65°F DB / 55°F WB while in the cooling, continuous fan, or dehumidification modes. Minimum entering air temperature while operating in the heating mode (not continuous fan) is the minimum entering air temperature for the standard model (without the ClimaDry II option) in the heating mode. Operating below these minimum entering air temperatures may result in nuisance faults.

ClimaDry® II – General Information

ClimaDry® II Modulating Reheat Option

ClimateMaster's patented ClimaDry® II Dehumidification option is an innovative means of providing modulating reheat without the complication of refrigeration controls. ClimaDry II is hot gas generated reheat, which utilizes one of the biggest advantages of a Water-Source Heat Pump (WSHP), the transfer of energy through the water piping system. ClimaDry II simply diverts condenser water through a water-to-air coil that is placed after the evaporator coil. If condenser water is not warm enough, the internal "run-around" loop increases the water temperature with each pass through the condenser coil (see figure 9, below).

ClimaDry® II Benefits

ClimaDry® II is like no other reheat option on the market. Proportional reheat is controlled to the desired leaving air temperature set point (factory set point of 72°F, 22°C), no matter what the water loop temperature is. Since dehumidification operation will occur under less than full load cooling conditions a good percentage of the time, it is important to have a reheat function that provides 100% reheat in the spring and fall when the water loop is cool. Supply air temperature is field adjustable to +/- 3°F [+/- 1.7°C] for even greater flexibility with the optional potentiometer. It is recommended that the ClimaDry II supply air temperature be set to match the space cooling setpoint so that ClimaDry II does not impact room temperature. Competitors without ClimaDry II typically use an on/off (non-modulating) refrigeration based reheat circuit, typically referred to as "Hot gas reheat" (HGR). HGR needs higher condensing temperatures to work

well, typically 85°F [29°C] entering water temperature (EWT). With HGR, cooler water temperatures produce cooler supply air temperatures, which could overcool the space, requiring additional space heating from another source or a special auto-change-over relay to allow the unit to switch back and forth between reheat and heating. Rarely does HGR provide 100% reheat, like ClimaDry II. ClimaDry II has a simple and easy to troubleshoot refrigerant circuit. No switching valves or hard to diagnose leaky check valves are utilized. No unusual refrigerant pressures occur during the reheat mode. The ClimaDry II refrigerant circuit is like every other ClimateMaster unit (without reheat), so everything the technician already knows applies to troubleshooting the ClimaDry II refrigeration circuit. Plus, the water loop portion of the ClimaDry II option is easy to understand and diagnose.

ClimaDry® II Applications

ClimaDry® II can be applied to a number of common applications, such as:

- Classrooms.
- Condominiums.
- Apartments.
- Computer rooms.
- Spaces with high latent loads like auditoriums, theaters, convention centers, etc.
- Most applications where humidity is a problem.

(NOTE: ClimaDry® II is not for use in high fraction outdoor air applications or in applications with corrosive atmospheres, such as pool rooms.)

Figure 9: ClimaDry® II Schematic

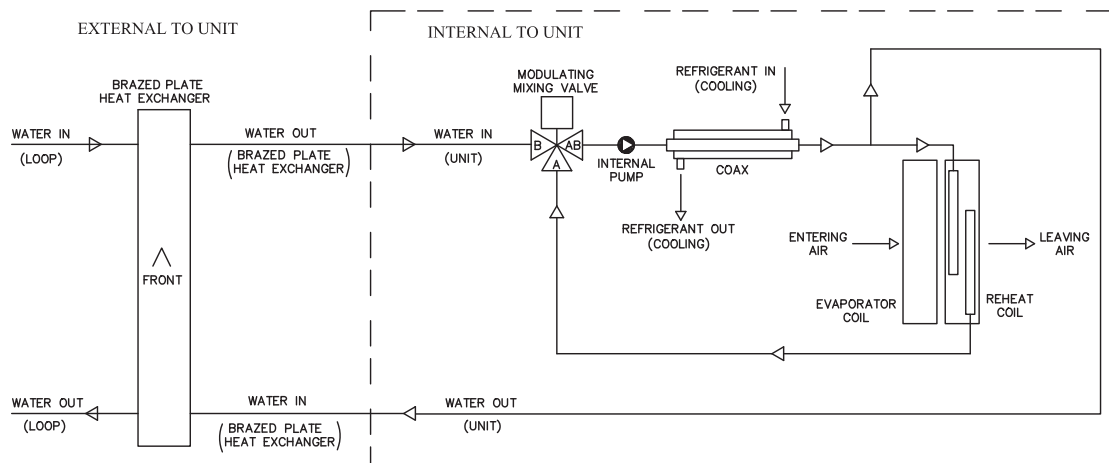

NOTE: Braze plate heat exchanger is used when connecting to a loop with no antifreeze.

Rooftop (TRT) Series

Rev.: November 5, 2024

ClimaDry® II – General Information, Cont'd.

With the ClimaDry® II option, return air from the space is cooled by the air-to-refrigerant (evaporator) coil, and then reheated by the water-to-air (reheat) coil to dehumidify the air, but maintain the same space temperature (thus operating as a dehumidifier).

The moisture removal capability of the heat pump is determined by the unit's latent capacity rating. Latent capacity equals Total capacity minus Sensible capacity. Using unit performance data from submittals (climatemaster.com) select the correct model, use your maximum entering water temperature (EWT) and flow rate to select TC and SC. For example, at 80°F [26.7°C] EWT and 15 GPM, the moisture removal capability (latent capacity) of a ClimateMaster TRE120 is 36.4 Mbtuh as shown in Figure 10.

Dividing the latent capacity by 1,069 BTU/LB of water vapor at 80°F DB and 67°F WB [26.7°C DB and 19.4°C WB] moist air enthalpy, converts the amount of moisture removal to pounds per hour (multiply pounds per hour by 0.4536 to obtain kg/hr). Calculations are shown in figure 10.

Most ClimateMaster heat pumps have a sensible-to-total (S/T) ratio of 0.72 to 0.82. Therefore, approximately, 25% of the cooling capacity is dedicated to latent cooling capacity (moisture removal). When selecting a unit with ClimaDry II, the space sensible and latent loads should be calculated. If the unit will be used for space cooling, a unit with at least enough capacity to satisfy the building sensible load should be selected. If the latent cooling load is not satisfied by the selection, a larger unit with enough latent capacity will be required. If the unit will be used for dehumidification purposes only, the latent capacity is the only consideration necessary. In this case, sensible load is immaterial.

Figure 10: Example TRE120 Performance
 4000 CFM Nominal (Rated) Airflow
 $LC = TC - SC = 121.2 - 84.8 = 36.4 \text{ Mbtuh}$
 $36,400 \text{ Btuh} \div 1,069 = 34.1 \text{ lbs/hr (15.4 kg/hr)}$

Water/Brine				Cooling - EAT 80/67°F					Heating - EAT 70°F				
EWT °F	Flow GPM	PD PSI	PD FT	TC	SC	kW	HR	EER	HC	kW	HE	LAT	COP
80	15.0	0.2	0.5	121.2	84.8	9.93	155.1	12.2	162.8	10.86	125.7	105.6	4.4
	22.5	0.4	1.0	126.2	87.0	9.28	157.9	13.6	171.5	11.08	133.7	107.6	4.5
	30.0	1.5	3.6	128.7	88.1	8.97	159.3	14.3	176.2	11.20	138.0	108.7	4.6
85	15.0	0.2	0.5	117.6	83.2	10.43	153.2	11.3	170.0	11.04	132.3	107.3	4.5
	22.5	0.4	0.9	122.6	85.4	9.75	155.9	12.6	179.2	11.27	140.7	109.4	4.7
	30.0	1.5	3.5	125.2	86.6	9.41	157.3	13.3	184.1	11.40	145.2	110.5	4.7
90	15.0	0.1	0.3	114.0	81.7	10.92	151.3	10.4	177.3	11.22	139.0	108.9	4.6
	22.5	0.4	0.9	119.1	83.9	10.21	153.9	11.7	186.8	11.47	147.7	111.1	4.8
	30.0	1.5	3.4	121.7	85.0	9.87	155.3	12.3	192.0	11.60	152.5	112.4	4.9
100	15.0	0.1	0.2	107.0	79.1	12.02	148.0	8.9	Operation not recommended				
	22.5	0.3	0.8	111.8	80.9	11.25	150.2	9.9					
	30.0	1.4	3.3	114.4	81.9	10.87	151.5	10.5					
110	15.0	0.1	0.2	100.5	77.2	13.24	145.6	7.6					
	22.5	0.3	0.7	104.8	78.4	12.40	147.1	8.5					
	30.0	1.4	3.2	107.2	79.1	12.00	148.1	8.9					
120	15.0	0.1	0.1	94.8	76.6	14.59	144.6	6.5					
	22.5	0.3	0.7	98.5	76.9	13.67	145.1	7.2					
	30.0	1.3	3.0	100.5	77.2	13.23	145.6	7.6					

Dividing the latent capacity by 1,069 BTU/LB of water vapor at 80°F DB and 67°F WB [26.7°C DB and 19.4°C WB] moist air enthalpy, converts the amount of moisture removal to pounds per hour (multiply pounds per hour by 0.4536 to obtain kg/hr). Calculations are shown in Figure 10.

ClimaDry® II – Sequence of Operation

ClimaDry® II Sequence of Operation

A heat pump equipped with ClimaDry® II can operate in three modes; cooling, cooling with reheat (dehumidification), and heating. The cooling/heating modes are like any other ClimateMaster WSHP. The reversing valve (“O” signal) is energized in cooling, along with the compressor contactor(s) and blower relay. In the heating mode the reversing valve is de-energized. Almost any thermostat will activate the heat pump in heating or cooling modes. The DXM2.5 microprocessor board, which is required with the ClimaDry II option, will accept either heat pump (Y, O) thermostats or non-heat pump (Y, W) thermostats. The reheat mode requires either a separate humidistat/dehumidistat or a thermostat that has an integrated dehumidification function for activation. The DXM2.5 board is configured to work with either a humidistat or dehumidistat input to terminal “H” (DIP Switch settings for the DXM2.5 board are shown below in table 4). Upon receiving an “H” input, the DXM2.5 board will activate the cooling mode and engage reheat. Tables 4 and 5 show the relationship between thermostat input signals and unit operation.

There are four operational inputs for single stage units and six operational inputs for dual stage units:

- Fan Only
- 1st Stage Cooling
- 2nd Stage Cooling
- 1st Stage Heating
- 2nd Stage Heating
- Reheat Mode

Fan Only: A (G) call from the thermostat to the (G) terminal of the DXM2.5 control board will bring the unit on in fan only mode.

1st Stage Cooling: A simultaneous call from (G), (Y1), and (O) to the (G), (Y1), (O/W2) terminals of the DXM2.5 control board will bring the unit on in 1st Stage Cooling.

2nd Stage Cooling: A simultaneous call from (G), (Y1), (Y2), and (O) to the (G), (Y1), (Y2), and (O/W2) terminals of the DXM2.5 control board will bring the unit on in 2nd Stage Cooling. When the call is satisfied at the thermostat the unit will continue to run in 1st Stage Cooling until the 1st Stage Cooling call is removed or satisfied, shutting down the unit. **NOTE: Not all units have two-stage cooling functionality. (e.g. TRT036-072 units)**

Table 4: Humidistat/Dehumidistat Logic and DXM2.5 (2.1, 2.2., 2.3) DIP settings

Sensor	2.1	2.2	2.3	Logic	Reheat (ON)–H	Reheat (OFF)–H
Humidistat	OFF	OFF	OFF	Reverse	0 VAC	24 VAC
Dehumidistat	OFF	ON	OFF	Standard	24 VAC	0 VAC

Table 5: ClimaDry® II Operating Modes

Mode	Input					Output				
	O	G	Y1	Y2 ³	H	O	G	Y1	Y2 ³	Reheat
No Demand	ON/OFF	OFF	OFF	OFF	OFF	ON/OFF	OFF	OFF	OFF	OFF
Fan Only	ON/OFF	ON	OFF	OFF	OFF	ON/OFF	ON	OFF	OFF	OFF
Cooling 1st Stage	ON	ON	ON	OFF	OFF	ON	ON	ON	OFF	OFF
Cooling 2nd Stage	ON	ON	ON	ON	OFF	ON	ON	ON	ON	OFF
Cooling & Dehumidistat ¹	ON	ON	ON	ON/OFF	ON	ON	ON	ON	ON/OFF	OFF
Dehumidistat Only	ON/OFF	OFF	OFF	OFF	ON	ON	ON	ON	ON	ON
Heating 1st Stage	OFF	ON	ON	OFF	OFF	OFF	ON	ON	OFF	OFF
Heating 2nd Stage	OFF	ON	ON	ON	OFF	OFF	ON	ON	ON	OFF
Heating & Dehumidistat ²	OFF	ON	ON	ON/OFF	ON	OFF	ON	ON	ON/OFF	OFF

¹Cooling input takes priority over dehumidify input.
²DXM2.5 is programmed to ignore the H demand when the unit is in heating mode.
³N/A for single stage units; Full load operation for dual capacity units.
⁴ON/OFF = Either ON or OFF.

Rooftop (TRT) Series

Rev.: November 5, 2024

ClimaDry® II – Sequence of Operation, Cont'd.

1st Stage Heating: A simultaneous call from (G) and (Y1) to the (G) and (Y1) terminals of the DXM2.5 control board will bring the unit on in 1st Stage Heating.

2nd Stage Heating: A simultaneous call from (G), (Y1), and (Y2) to the (G), (Y1), and (Y2) terminals of the DXM2.5 control board will bring the unit on in 2nd Stage Heating. When the call is satisfied at the thermostat the unit will continue to run in 1st Stage Heating until the call is removed or satisfied, shutting down the unit. **NOTE: Not all units have two-stage heating functionality (e.g. TRE036-072 units).**

Reheat Mode: A call from the Humidistat/Dehumidistat to the (H) terminal of the DXM2.5 control board will bring the unit on in Reheat Mode if there is no call for cooling at the thermostat. When the Humidistat/Dehumidification call is removed or satisfied the unit will shut down. **NOTE: Cooling always overrides Reheat Mode. In the Cooling mode, the unit cools and dehumidifies. If the cooling thermostat is satisfied but there is still a call for dehumidification, the unit will continue to operate in Reheat Mode.**

NOTE: Care must be taken when using a humidistat to operate ClimaDry® II. When the DIP Switch on the DXM2.5 controller is set for 'humidistat' it reverses the control logic so that an "open" control circuit initiates a ClimaDry II run cycle. If a humidistat is not connected, or if a manual switch on the humidistat is set to "off", ClimaDry II will see the open circuit and call for dehumidification.

TRT ClimaDry® II Component Functions

The ClimaDry® II option consists of the following components:

- Motorized Valve/Proportional Controller
- Supply Air Sensor
- Loop Pump
- Hydronic Coil
- Low Pressure Switch

The Proportional Controller operates on 24 VAC power supply and automatically adjusts the water valve based upon the Supply Air Sensor. The Supply Air Sensor senses supply air temperature at the blower inlet providing the input signal necessary for the proportional control to drive the motorized valve during the reheat mode of operation.

The Motorized Valve is a proportional actuator/three-way valve combination used to divert the condenser water from the coax to the hydronic reheat coil during the reheat mode of operation. The proportional controller signals the motorized valve based on the supply air temperature of the supply air sensor.

The Loop Pump circulates condenser water through the hydronic reheat coil during the reheat mode of operation. In this application, the loop pump is only energized during the reheat mode of operation. The Hydronic Coil is utilized during the reheat mode of operation to reheat the air to the setpoint of the proportional controller. Condenser water is diverted by the motorized valve and pumped through the hydronic coil by the loop pump in proportion to the control setpoint. The amount of reheating is dependent on the setpoint and how far from setpoint the supply air temperature is. The factory setpoint is 72°F [22°C], generally considered "neutral" air.

ClimaDry® II Application Considerations

The reheat coil adds a small amount of resistance to the air stream. In some cases the high static option may be required for applications with higher static ductwork. Consult the submittal data or the Installation/Operation/Maintenance (I.O.M.) manual for the specific heat pump to review blower tables.

Unlike most hot gas reheat options, the ClimaDry® II option will operate over a wide range of EWTs. Special flow regulation (water regulating valve) is not required for low EWT conditions.

TRT units with the ClimaDry II option shall have an antifreeze solution to protect the coil in low ambient conditions. ASHRAE minimums for the region shall be considered during the calculation of the antifreeze solution.

In applications where antifreeze is not specified, a secondary heat exchanger can be used to isolate the TRT from the water loop, thus requiring less antifreeze to be used with the TRT Secondary brazed plate heat exchanger. Figure 9 shows the heat exchanger connections.

Water-source heat pumps with ClimaDry II should not be used as make-up air units. These applications should use equipment specifically designed for make-up air.

Blower Performance Data – Units with ClimaDry® II

Coil Face Velocity FPM	ERE with Reheat - ESP Loss	
	TRT036 & 048 in. of Water	TRT060 & 072 in. of Water
175	-	-
200	0.17	0.17
225	0.18	0.18
250	0.20	0.20
275	0.21	0.21
300	0.22	0.23
325	0.23	0.24
350	0.25	0.26
375	0.26	0.27
400	0.27	0.29
425	-	0.30
450	-	0.31
475	-	-
500	-	-
525	-	-
550	-	-
575	-	-

Example:

Reheat coil loss can be determined from the above table.

$$\text{Coil velocity (FPM)} = \text{Airflow (CFM)} / \text{Face Area (sq. ft.)}$$

1. TRT=036 has a face area of 5 sq. ft. (see physical data table).
2. At 1,500 CFM, coil velocity (FPM) = 1,500 / 5 = 300 FPM
3. From above table, ESP is .22.
4. TRT036 (without reheat) C Drive at .6 ESP, 3.0 turns = 1,500 CFM
TRT036 (with reheat) C Drive at .82 ESP, 3.0 turns = 1,400 CFM
If drop in CFM is not acceptable, adjust turns to 2.0 for 1,500 CFM.

NOTE: Sometimes drive package must be changed.

Air Coil Face Area

Model	Square Feet
TRT036 - 048	5.0
TRT060 - 072	7.0

NOTE: For blower performance, see unit IOM or submittal.

Rooftop (TRT) Series

Rev.: November 5, 2024

Flushing/Purging Units with ClimaDry® II

When flushing/purging units equipped with ClimaDry® II the unit should be fully flushed/purged before attempting to flush/purge the ClimaDry II coil. Once the unit is flushed, energize the modulating three-way dehumidification valve to allow flow through the ClimaDry II hydronic circuit.

The unit must be powered (but not operating) during flushing/purging. Unit power is required to operate the three-way modulating valve during flushing.

Energize the modulating three-way dehumidification valve by removing the red wire from the ACC1 'N.O.' terminal on the DXM2.5 board. Connect this wire to the ACC1 'NC' terminal of the DXM2.5 controller, as shown in Figure 9, to energize the modulating three-way dehumidification valve. Once energized, the valve will take 45 – 75 seconds to fully shift. Continue flushing during this time. After the valve has completed its shift, use the air bleed from the top of the reheat coil to purge air from the coil.

NOTE: If the ClimaDry II sensor, located in the supply air stream is above 70°F it must be disabled to allow the modulating valve to shift. Disable this sensor by removing the white wire from the Low Voltage Terminal Block (LVTB) shown in Figure 10.

Figure 11. Flushing/Purging Wiring

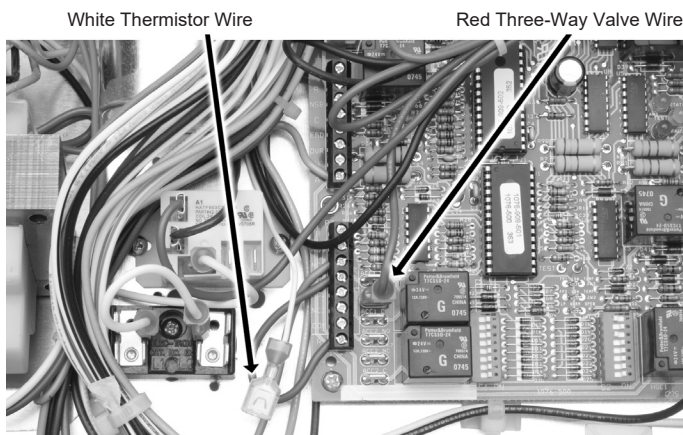

De-energize the valve by removing the red wire from the ACC1 'NC' terminal on the DXM2.5 board. The valve will spring return to its normal position in just a few seconds. After the valve has fully returned, repeat the process of running the valve through its cycle and purging air from the reheat coil.

Under extreme circumstances this procedure may be required multiple times to purge all air from the circuit. After completing the flushing/purging procedure, reconnect the red wire to the ACC1 'N.O.' terminal on the DXM2.5 for normal operation. Reconnect the white sensor wire to the LVTB, if it was removed, as shown in figure 12.

If air is allowed to collect in the ClimaDry II piping, nuisance trips may occur. Additional flush/purge cycles may be used when required.

Figure 12. Normal Unit Wiring

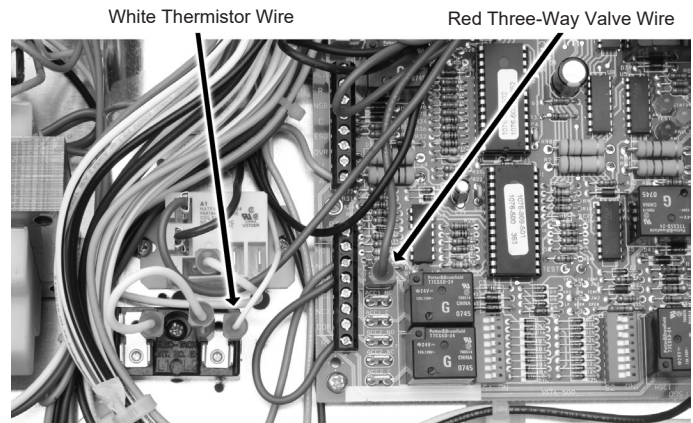

Operating and Commissioning Limits

Operating Limits

Environment - Units are designed for roof mount or indoor installation.

Power Supply - A voltage variation of +/- 10% of nameplate utilization voltage is acceptable.

Determination of operating limits is dependent primarily on three factors: 1) Return Air Temperature, 2) Entering Water Temperature, and 3) Ambient Temperature. When any one of these factors is at minimum or maximum levels, the other two factors must be at normal levels to ensure proper unit operation. Extreme variation in temperature and humidity and/or corrosive water or air will adversely affect unit performance, reliability, and service life. Consult Table 6a for operating limits.

Table 6a: Building Operating Limits

Air Temperature Limits	Cooling	Heating
Minimum Entering Air	60°F [15.5°C]	50°F [10°C]
Maximum Entering Air DB	90°F [32.2°C]	80°F [27°C]
Water Temperature Limits	Cooling	Heating
Minimum Entering Fluid	40°F [4°C]	20°F [-6.7°C]
Maximum Entering Fluid	120°F [48.9°C]	90°F [32.2°C]

Commissioning Limits

Consult Table 6b

NOTES:

- Limits on Table 6b are not normal or continuous operating conditions. Minimum/Maximum limits are commissioning limits to bring the building up to normal occupancy temperatures. Units are not designed/intended to operate under these limits on a regular or ongoing basis.
- Voltage utilization range complies with AHRI Standard 110.

Table 6b: Building Commissioning Limits

Air Temperature Limits	Cooling	Heating
Minimum Entering Air	40°F [4.4°C]	40°F [4°C]
Maximum Entering Air DB	110°F [43°C]	80°F [27°C]
Water Temperature Limits	Cooling	Heating
Minimum Entering Fluid	40°F [4°C]	20°F [-6.7°C]
Maximum Entering Fluid	120°F [48.9°C]	90°F [32.2°C]

Rooftop (TRT) Series

Rev.: November 5, 2024

Start-Up Preparation

⚠ WARNING! ⚠

WARNING! To prevent injury or death due to electrical shock or contact with moving parts, open unit disconnect before servicing unit.

System Cleaning and Flushing

Cleaning and flushing the unit is the single most important step to ensure proper start-up and continued efficient operation of the system.

Follow the instructions below to properly clean and flush the system:

1. Verify that electrical power to the units is disconnected.
2. Install the system with the supply hose connected directly to the return riser valve. Use a single length of flexible hose.
3. Open all air vents. Fill the system with water. Do not allow system to overflow. Bleed all air from the system. Check the system for leaks and repair appropriately.
4. Verify that all strainers are in place. Start the pumps and systematically check each vent to ensure that all air is bled from the system.
5. Verify that makeup water is available. Adjust makeup water appropriately to replace the air which was bled from the system. Check and adjust the water/air level in the expansion tank.
6. Set the boiler (when used) to raise the loop temperature to approximately 85°F. Open a drain at the lowest point in the system. Adjust the makeup water replacement rate to equal the rate of bleed.
7. Refill the system and add trisodium phosphate in a proportion of approximately one pound per 150 gallons of water. Reset the boiler (when used) to raise the loop temperature to about 100°F.
8. Circulate the solution for a minimum of eight to 24 hours. At the end of this period, shut off the circulating pump and drain the solution. Repeat system cleaning if necessary.
9. When the cleaning process is complete, remove the short-circuited hoses. Reconnect the hoses to the proper supply and return the connections to each of the Rooftop Units. Refill the system and bleed off all air.

⚠ CAUTION! ⚠

CAUTION! To avoid possible damage to piping systems constructed of plastic piping, DO NOT allow loop temperature to exceed 115° F.

10. Add antifreeze to the system in climates where ambient temperature falls below freezing, using the proportion of antifreeze shown in Table 7. The volume of antifreeze required will vary based on outdoor design temperature.
11. Test the system pH with litmus paper. The system water should be slightly alkaline (pH 7.5 to 8.5).Add chemicals as appropriate to maintain acidity levels.
12. When the system is successfully cleaned, flushed, refilled and bled, check the main system panels, safety cutouts, and alarms. Set the controls to properly maintain loop temperatures.

⚠ CAUTION! ⚠

CAUTION! Do Not use “Stop-Leak” or any similar chemical agent in this system. Addition of these chemicals to the loop water will foul the system and will inhibit unit operation.

Table 7: Percent Antifreeze Required By Volume

Antifreeze	Minimum Ambient Temperature			
	0°F	10°F	20°F	30°F
Methanol	25%	21%	16%	10%
Propylene Glycol	26%	23%	19%	9%
Ethylene Glycol	24%	20%	16%	12%

NOTE: The manufacturer strongly recommends all piping connections, both internal and external to the unit, be pressure tested by an appropriate method prior to any finishing of the interior space or before access to all connections is limited. Test pressure may not exceed the maximum allowable pressure for the unit and all components within the water system. The manufacturer will not be responsible or liable for damages from water leaks due to inadequate or lack of a pressurized leak test, or damages caused by exceeding the maximum pressure rating during installation.

⚠ CAUTION! ⚠

INSTALLER CAUTION! After making water connections on units equipped with ClimaDry®, ensure the three union nuts on the internal three-way valve are tight.

Blower Adjustment

CAUTION!

CAUTION! Always disconnect all power supply(s) to unit prior to making belt or sheave adjustments. Inadvertently starting of the motor can cause damage to the equipment and personal injury.

Airflow and External Static Pressure Selection Adjustment

The TRT Series comes standard with a large high RPM blower motor. This motor is capable of operating over a large ESP range. Depending on the mode of operation, the TRT series will either operate to a desired LAT or a discrete airflow speed (see Blower Motor Variable Frequency Drive (VFD) Controls section).

Sheave Adjustment

The TRT Series is supplied with a Variable Frequency Drive standard and in the field sheave adjustment should not be required.

Belt Tensioning

An overly loose belt will, upon motor start, produce a slippage 'squeel' and cause premature belt failure and or intermittent airflow. An overly tight belt can cause premature motor or blower bearing failure.

Belt Tensioning Procedure - TRT

Blower motors for TRT models are slide base mounted.

To adjust the belt tension:

1. Loosen the two (2) bolts that lock the base to the slide rails.
2. Locate the adjusting bolt on the left side of the base assembly.
3. Turn counter clock wise to tighten or clock wise to loosen the belt.
4. The belt should be tensioned using a tension gauge method such as the Browning Belt Tensioner to set proper belt tension (see next page).
5. After belt tension is set secure the (2) locking bolts.

NOTES:

- Motor position should not need adjustment.
- Motor sheave position is at mid position of each sheave. Thus the motor sheave is typically 2.5 turns open on a 5 turn sheave.

Rooftop (TRT) Series

Rev.: November 5, 2024

Tensioning V-Belt Drives

General Rules of Tensioning

1. Ideal tension is the lowest tension at which the belt will not slip under peak load conditions.
2. Check tension frequently during the first 24-48 hours of operation.
3. Over tensioning shortens belt and bearing life.
4. Keep belts free from foreign material which may cause slip.
5. Make V-drive inspection on periodic basis. Tension when slipping. Never apply belt dressing as this will damage the belt and cause early failure.

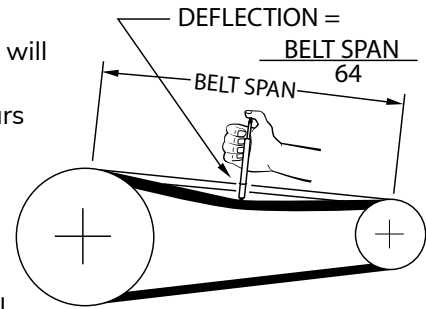

Tension Measurement Procedure

1. Measure the belt span (see sketch).
2. Position bottom of the large "O" ring on the span scale at the measured belt span.
3. Set the small "O" ring on the deflection force scale to zero.
4. Place the tension checker squarely on one belt at the center of the belt span. Apply a force on the plunger and perpendicular to the belt span until the bottom of the large "O" ring is even with the top of the next belt or with the bottom of a straight edge laid across the sheaves.
5. Remove the tension checker and read the force applied from the bottom of the small "O" ring on the deflection force scale.
6. Compare the force you have applied with the values given in the table below. The force should be between the minimum and maximum shown. The maximum value is shown for "New Belt" and new belts should be tensioned at this value to allow for expected tension loss. Used belts should be maintained at the minimum value as indicated in the table below.

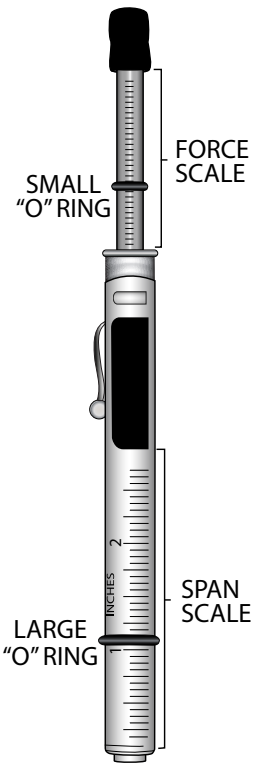

NOTE: The ratio of deflection to belt span is 1:64.

Cross Section	Smallest Sheave Diameter Range	RPM Range	Belt Deflection Force			
			Super Gripbelts and Unnotched Gripbands		Gripnotch Belts and Notched Gripbands	
			Used Belt	New Belt	Used Belt	New Belt
A, AX	7.6 - 9.1	1000 - 2500 2501 - 4000	16.458	24.464	18.237	27.133
			12.454	18.682	15.123	22.240
	9.6 - 12.2	1000 - 2500 2501 - 4000	20.016	30.246	22.240	32.915
B, BX	8.6 - 10.7	860 - 2500 2501 - 4000	-	-	21.795	32.026
			-	-	18.682	27.578
	11.2 - 14.2	860 - 2500 2501 - 4000	23.574	35.139	36.029	46.704
14.7 - 21.8	860 - 2500 2501 - 4000	28.022	41.811	37.808	56.045	
		26.688	39.587	32.470	48.483	

Unit System Checkout

- ❑ **Voltage:** Ensure that voltage is within the utilization range specifications of the unit compressor and fan motor.
- ❑ **System Water Temperature:** Ensure that it is within an acceptable range to facilitate start-up. (When conducting this check, also verify proper heating and cooling setpoints.)
- ❑ **System Water pH:** Verify system water acidity. (pH = 7.5 or 8.5) Proper pH promotes the longevity of hoses and heat exchangers.
- ❑ **System Flushing:** Properly clean and flush system periodically. Ensure that all supply and return hoses are connected end-to-end to facilitate system flushing and prevent fouling of the heat exchanger by system water. Water used in the system must be of potable quality and clean of dirt, piping slag, and chemical cleaning agents.
- ❑ **Closed-Type Cooling Tower or Open Tower with Heat Exchanger:** Check equipment for proper temperature set points and operation.
- ❑ **Water Flow Rate to Heat Pump:** System is balanced.
- ❑ **Standby Pump:** Verify that the standby pump is properly installed and in operating condition.
- ❑ **Control Box:** Tighten/check all electrical connections. Ensure transformer is wired on correct voltage TAP (208 - 230 Volt only).
- ❑ **Access Panels:** Assure that all access panels in the filter and fan section are securely closed.
- ❑ **Air Dampers:** Assure that all air dampers are properly set.
- ❑ **System Controls:** To ensure that no catastrophic system failures occur, verify that system controls are functioning and that the sequencing is correct.
- ❑ **Freeze Protection for Water System:** Verify that freeze protection is provided for the building loop water system when outdoor design conditions require antifreeze. Inadequate freeze protection can lead to expensive tower and system piping repairs.
- ❑ **System Water Loop:** Verify that all air is bled from the system. Air in the system impedes unit operation and causes corrosion in the system piping.
- ❑ **Unit Filters:** To avoid system damage, ensure that the unit filter is clean.
- ❑ **Unit Fans:** Manually rotate fans to assure free rotation. Ensure that fans are properly secured to the fan shaft. Do not oil fan motors on start-up since they are lubricated at the factory.
- ❑ **System Control Center:** To ensure control of the temperature set-points for operation of the system's heat rejector and boiler (when used), examine the system control and alarm panel for proper installation and operation.
- ❑ **Miscellaneous:** Note any questionable aspects of the installation.

Rooftop (TRT) Series

Rev.: November 5, 2024

Unit Start-Up

! WARNING! !

WARNING! Polyolester Oil, commonly known as POE oil, is a synthetic oil used in many refrigeration systems including those with HFC-410A refrigerant. POE oil, if it ever comes in contact with PVC or CPVC piping, may cause failure of the PVC/CPVC. PVC/CPVC piping should never be used as supply or return water piping with water source heat pump products containing HFC-410A as system failures and property damage may result.

! WARNING! !

WARNING! When the disconnect switch is closed, high voltage is present in some areas of the electrical panel. Exercise caution when working with energized equipment.

NOTE: Rooftop heat pump units are designed to start heating at a minimum return air temperature of 40°F with normal water flow rate and ambient temperature.

1. Adjust all water valves to their full open position. Turn on the line power to all heat pump units.
2. Operate each unit in the cooling cycle. Room temperature should be approximately 70° to 75°F DB, and 61° to 65°F WB. Loop water temperature entering the heat pumps should be between 60°F and 110°F. When the unit is operating in the cooling mode under AHRI conditions, the leaving water temperature is approximately 10°F warmer than the entering water temperature at 3 GPM / ton.
 - a. Adjust the unit thermostat to the coolest position. If the unit has a MCO thermostat, set the selector switch to cool. Both the fan and compressor should run. For heat pumps with ACO, adjust the cooling set point to a temperature at least 3°F below room temperature.
 - b. Check for cool air delivery at the unit grille within a few minutes after the unit has begun to operate. List the identification number of any machines that do not function.
3. Operate each heat pump in the heating cycle immediately after checking cooling cycle operation. A time delay will prevent the compressor from restarting for approximately 5 minutes.
 - a. If the unit has a MCO thermostat, set the temperature indicator to the highest setting and set the selector switch to HEAT. The fan and the compressor should start. If the unit has an optional ACO thermostat, set the temperature indicator to the highest setting and set the selector switch to AUTO. The fan and the compressor should start.
 - b. Once the unit has begun to run, check for warm air delivery at the unit grille. List the serial number of any machines that do not function.
4. Establish a permanent operating record by logging the unit operating conditions at initial start-up for each unit.
5. If a unit fails to operate, conduct the following checks:
 - a. Check the voltage and current. They should comply with the electrical specifications described on the unit nameplate.
 - b. Look for wiring errors. Check for loose terminal screws where wire connections have been made on both the line and low-voltage terminal boards.
 - c. Check for dirty filters. A clogged filter will cause safety cutouts to stop unit operation.
 - d. Check the supply and return piping. They must be properly connected to the inlet and outlet connections on the unit.
 - e. Check the fan. If the fan fails to operate, verify that the fan wheel turns freely and that it is secured to the shaft. Also verify that the fan operates in both heating and cooling modes.
 - f. If the checks described above fail to reveal the problem and the unit still will not operate, contact a trained service technician to ensure proper diagnosis and repair of the equipment.

Operating Temperatures and Pressures

Table 8: Operating Temperatures and Pressures

Entering Water Temp °F	Water Flow GPM/ton	Cooling						Heating																	
		Suction Pressure PSIG	Discharge Pressure PSIG	Superheat	Subcooling	Water Temp Rise °F	Air Temp Drop °F DB	Suction Pressure PSIG	Discharge Pressure PSIG	Superheat	Subcooling	Water Temp Drop °F	Air Temp Rise °F DB												
20	1.5																								
	2.25																								
	3																								
30*	1.5	123-133	176-206	19-29	19-29	21-25	20-22	62-72	291-321	6-16	4-10	7-9	18-22												
	2.25	111-131	164-184	25-35	18-28	14-16	18-22	67-77	291-331	6-16	4-10	5-7	20-22												
	3	107-127	156-176	29-39	17-27	10-12	16-22	69-79	294-334	6-16	4-10	4-6	21-23												
50	1.5	129-139	225-255	10-20	13-23	20-24	19-25	93-103	320-360	5-15	6-12	10-12	25-27												
	2.25	128-138	213-233	15-25	12-22	12-16	19-23	99-109	325-365	6-16	6-12	7-9	26-28												
	3	126-136	203-223	18-28	12-22	10-12	19-23	103-113	329-369	6-16	6-12	5-7	27-29												
70	1.5	135-145	300-330	5-15	12-22	19-23	19-21	125-135	247-397	6-16	6-12	14-16	31-33												
	2.25	135-145	281-301	6-16	10-20	12-16	18-22	135-145	362-402	6-16	5-11	10-12	33-35												
	3	134-144	269-289	7-17	8-18	8-14	17-23	139-149	361-411	7-17	5-11	7-9	33-35												
90	1.5	140-150	386-426	3-13	13-23	17-23	17-21	160-170	382-432	8-18	5-11	17-19	36-40												
	2.25	139-149	366-396	4-14	10-20	11-15	17-21	164-184	388-448	11-21	5-11	11-15	39-41												
	3	138-148	358-378	4-14	8-18	9-11	17-21	170-190	395-455	12-22	5-11	9-11	38-42												
100	1.5	138-158	428-478	3-13	13-23	16-22	16-20																		
	2.25	137-157	409-449	3-13	10-20	11-15	17-21																		
	3	141-151	397-437	4-14	8-18	9-11	17-21																		
120	1.5	144-164	544-574	2-12	11-21	15-21	11-15																		
	2.25	143-163	511-571	3-13	10-20	10-14	15-19																		
	3	142-162	495-555	3-13	8-18	7-11	14-20																		

*Based on 15% Methanol antifreeze solution

Rooftop (TRT) Series

Rev.: November 5, 2024

Start-Up Log Sheet

Installer: Complete unit and system checkout and follow unit start-up procedures in the IOM. Use this form to record unit information, temperatures and pressures during start-up. Keep this form for future reference.

Job Name: _____ **Street Address:** _____

Model Number: _____ **Serial Number:** _____

Unit Location in Building: _____

Date: _____ **Sales Order No:** _____

In order to minimize troubleshooting and costly system failures, complete the following checks and data entries before the system is put into full operation.

External Static: _____

Sheave Setting: _____ Turns

Temperatures: F or C

Antifreeze: _____ %

Pressures: PSIG or kPa

Type _____

Cooling Mode

Heating Mode

Entering Fluid Temperature				
Leaving Fluid Temperature				
Temperature Differential				
Return-Air Temperature	DB	WB	DB	WB
Supply-Air Temperature	DB	WB	DB	WB
Temperature Differential				
Water Coil Heat Exchanger (Water Pressure IN)				
Water Coil Heat Exchanger (Water Pressure OUT)				
Pressure Differential				
Compressor				
Amps				
Volts				
Discharge Line Temperature				
Motor				
Amps				
Volts				

Allow unit to run 15 minutes in each mode before taking data.

Do not connect gage lines.

Preventive Maintenance

Maintenance Procedures

Perform the maintenance procedures outlined below periodically as indicated.

WARNING!

WARNING! To prevent injury or death due to electrical shock or contact with moving parts, open unit disconnect switch before servicing unit.

Filters

Inspect filters. Establish a regular maintenance schedule. Clean filter and maintenance frequently depending upon need. To remove the filter from a Rooftop Unit, slide the filter out of its frame located in the return air opening. When reinstalling the filter, use the slide-in rails of the filter frame to guide the filter into the proper position. Verify that the airflow arrow found on the top of each filter points toward the unit. Always replace filters with the same size and quantity of filters as removed from the unit.

CAUTION!

CAUTION! To avoid fouled machinery and extensive unit cleanup, do not operate units without filters in place. Do not use equipment as a temporary heat source during construction.

Condensate Pans

Check condensate drain pans for algae growth every three months. If algae growth is apparent, consult a water treatment specialist for proper chemical treatment. The application of an algaecide every three months will typically eliminate algae problems in most locations.

Air Coil

Inspect the air coil annually for dirt accumulation. Clean coil as needed using a spray-on foaming coil cleaner. Rinse with clean water. Brushing coils should be avoided to avoid damage to coil fins.

Fan Motors

Lubricate fan motors annually. All ClimateMaster Rooftop Units are fully lubricated at the factory. Do not oil during installation.

Conduct Amperage checks annually. Amp draw should not exceed normal full load or rated load amps by more than 10 percent of the values noted on the unit nameplate. Maintain a log of Amperage values to detect deterioration prior to component failure.

Unit Insection

Visually inspect the unit annually. Pay special attention to hose assemblies. Repair any leaks and replace deteriorated hoses immediately.

Compressor

Conduct an Amperage check on the compressor(s) annually. Amp draw should not exceed normal full load or rated load amps by more than 10 percent of the values noted on the unit nameplate. Maintain a log of Amperage values to detect deterioration prior to component failure.

WARNING!

WARNING! When replacing the compressor contactor or lockout controls, use only ClimateMaster replacement parts. Substitution of other components may result in an inoperative safety circuit and may cause a hazardous condition.

Rooftop (TRT) Series

Rev.: November 5, 2024

Warranty



**CLIMATE MASTER, INC.
LIMITED EXPRESS WARRANTY/ LIMITATION OF REMEDIES AND LIABILITY**

It is expressly understood that unless a statement is specifically identified as a warranty, statements made by Climate Master, Inc., a Delaware corporation, ("CM") or its representatives, relating to CM's products, whether oral, written or contained in any sales literature, catalog or any other agreement, are not express warranties and do not form a part of the basis of the bargain, but are merely CM's opinion or commendation of CM's products.

EXCEPT AS SPECIFICALLY SET FORTH HEREIN, THERE IS NO EXPRESS WARRANTY AS TO ANY OF CM'S PRODUCTS. CM MAKES NO WARRANTY AGAINST LATENT DEFECTS. CM MAKES NO WARRANTY OF MERCHANTABILITY OF THE GOODS OR OF THE FITNESS OF THE GOODS FOR ANY PARTICULAR PURPOSE.

GRANT OF LIMITED EXPRESS WARRANTY

CM warrants CM products purchased and retained in the United States of America and Canada to be free from defects in material and workmanship under normal use and maintenance as follows: (1) All complete air conditioning, heating and/or heat pump units built or sold by CM for twelve (12) months from date of unit start up or eighteen (18) months from date of shipment (from factory), whichever comes first; (2) Repair and replacement parts, which are not supplied under warranty, for ninety (90) days from date of shipment (from factory). All parts must be returned to CM's factory in Oklahoma City, Oklahoma, freight prepaid, no later than sixty (60) days after the date of the failure of the part; if CM determines the part to be defective and within CM's Limited Express Warranty, CM shall, when such part has been either replaced or repaired, return such to a factory recognized dealer, contractor or service organization, F.O.B. CM's factory, Oklahoma City, Oklahoma, freight prepaid. The warranty on any parts replaced or repaired under warranty expires at the end of the original warranty period.

This warranty does not cover and does not apply to: (1) Air filters, fuses, refrigerant, fluids, oil; (2) Products relocated after initial installation; (3) Any portion or component of any system that is not supplied by CM, regardless of the cause of the failure of such portion or component; (4) Products on which the unit identification tags or labels have been removed or defaced; (5) Products on which payment to CM has been in default; (6) Products which have been subjected to lightning, fire, flood, accident, shortages of transportation, fuel, material, or labor, acts of God or any other reason beyond the sole control of CM; (7) Products which have defects or damage which result from a contaminated or corrosive air or liquid supply, operations at abnormal temperatures, or unauthorized opening of refrigerant circuit; (8) Mold, fungus or bacteria damages; (9) Products subjected to corrosion or abrasion; (10) Products manufactured or supplied by others; (11) Products which have been subjected to misuse, negligence or accidents; (12) Products which have been operated in a manner contrary to CM's printed instructions; or (13) Products which have defects, damage or insufficient performance as a result of insufficient or incorrect system design or the improper application of CM's products.

CM is not responsible for: (1) The costs of any fluids, refrigerant or other system components, or associated labor to repair or replace the same, which is incurred as a result of a defective part covered by CM's Limited Express Warranty; (2) The costs of labor, refrigerant, materials or service incurred in removal of the defective part, or in obtaining and replacing the new or repaired part; or, (3) Transportation costs of the defective part from the installation site to CM or of the return of any part not covered by CM's Limited Express Warranty.

Limitation: This Limited Express Warranty is given in lieu of all other warranties. If, notwithstanding the disclaimers contained herein, it is determined that other warranties exist, any such warranties, including without limitation any express warranties or any implied warranties of fitness for particular purpose and merchantability, shall be limited to the duration of the Limited Express Warranty.

LIMITATION OF REMEDIES

In the event of a breach of this Limited Express Warranty, CM will only be obligated at CM's option to repair the failed part or unit or to furnish a new or rebuilt part or unit in exchange for the part or unit which has failed. If CM is unable to repair or replace the failed part or unit, CM shall refund the purchase price paid to CM in exchange for the return of the solid goods. Said refund shall be the maximum liability of CM. **THIS REMEDY IS THE SOLE AND EXCLUSIVE REMEDY OF THE BUYER OR THEIR PURCHASER AGAINST CM FOR BREACH OF CONTRACT, FOR THE BREACH OF ANY WARRANTY OR FOR CM'S NEGLIGENCE OR IN STRICT LIABILITY.**

LIMITATION OF LIABILITY

CM shall have no liability for any damages if CM's performance is delayed for any reason or is prevented to any extent by any event such as, but not limited to, any war, civil unrest, government restrictions or restraints, strikes or work stoppages, fire, flood, accident, shortages of transportation, fuel, material, or labor, acts of God or any other reason beyond the sole control of CM. **CM EXPRESSLY DISCLAIMS AND EXCLUDES ANY LIABILITY FOR CONSEQUENTIAL OR INCIDENTAL DAMAGE IN CONTRACT, FOR BREACH OF ANY EXPRESS OR IMPLIED WARRANTY, OR IN TORT, WHETHER FOR CM'S NEGLIGENCE OR AS STRICT LIABILITY.**

OBTAINING WARRANTY PERFORMANCE

Normally, the contractor or service organization who installed the products will provide warranty performance for the owner. Should the installer be unavailable, contact any CM recognized dealer, contractor or service organization. If assistance is required in obtaining warranty performance, write or call:

Climate Master, Inc. • Customer Service • 7300 S.W. 44th Street • Oklahoma City, Oklahoma 73179 (405) 745-6000

NOTE: Some states or Canadian provinces do not allow limitations on how long an implied warranty lasts, or the limitation or exclusions of consequential or incidental damages, so the foregoing exclusions and limitations may not apply to you. This warranty gives you specific legal rights, and you may also have other rights which vary from state to state and from Canadian province to Canadian province.

Please refer to the CM Installation, Operation and Maintenance Manual for operating and maintenance instructions.

Rev.: 11/09



LC083

Notes:

Rooftop (TRT) Series

Rev.: November 5, 2024

Revision History

Date:	Item:	Action:
11/05/24	Electrical Data	Updated ClimaDry/Secondary Pump and Standard Electrical Data
11/21/22	ALL	Upgraded DXM2 to DXM2.5 unit controls
11/18/21	Updated Various Text	All pages
11/11/21	Removed LON Controls	All pages
10/5/21	All	Part Number Corrected from LC1084 to Correct 97B part number
	Water Quality Standards	Updated pgs 9-12
09/24/21	Decoder	Updated Curb decoder pg 3
08/4/21	Decoder	Updated decoder pg 3
04/23/20	Document Created	



A NIBE GROUP MEMBER

7300 S.W. 44th Street
 Oklahoma City, OK 73179
 Phone: 405-745-6000
 Fax: 405-745-6058
 climatemaster.com

ClimateMaster works continually to improve its products. As a result, the design and specifications of each product at the time for order may be changed without notice and may not be as described herein. Please contact ClimateMaster’s Customer Service Department at 1-405-745-6000 for specific information on the current design and specifications. Statements and other information contained herein are not express warranties and do not form the basis of any bargain between the parties, but are merely ClimateMaster’s opinion or commendation of its products.