

**TRANQUILITY[®] MODULAR
(817) VERTICAL STACK
CHASSIS**



**COMMERCIAL VERTICAL
STACK WATER-SOURCE
HEAT PUMP CHASSIS**
FOR INSTALLATION IN EXISTING
CLIMATEMASTER AND CHP
CABINETS

**INSTALLATION,
OPERATION
& MAINTENANCE**

97B0056N02
Revised: 12 January, 2022



Table of Contents

817 Model Nomenclature	3
General Information	4
Cabinet and Chassis Pre-Installation and Chassis	
Installation	6
Electrical Data	8
817 Series Wiring Diagram Matrix	8
Wire Diagrams	9
Preventive Maintenance	13
Start-up Log Sheet	14
Functional Troubleshooting	15
Performance Troubleshooting	16
Troubleshooting Form	17
Warranty	18
Revision History	20

817 Chassis

Rev.:01/12/22

This Page Intentionally Left Blank

817 Model Nomenclature

Chassis

	1	2	3	4	5	6	7	8	9	10	11	12	13
	8	1	7	0	9	G	S	P	S	S	C	S	A

Series
817 = TRANQUILITY
HIGH RISE
REPLACEMENT CHASSIS

Unit Size
09
12
24
30
36

Voltage
E = 265/60/1
G = 208-230/60/1

OPTION	S.S. Drain Pan	MUTE
A	X	-
S	-	-
1	-	X
2	X	X

Controls
P = Standard (24V N.C. Safeties) for use with CXM or DXM
M = Combination Controls (24V N.C. Safeties) For use w/either Electro-Mechanical or CMC Controls. (Compare with Cabinet Decoder for Compatibility)
S = Standard (Line Voltage, Pilot Duty Lock-Out Relay, Original chassis had N.O. Switches. Replacement has N.C. High Pressure Switch, Low Pressure Switch or High Discharge Temp Switch, FreezeStat and Quick Connect cord. (Compare with Cabinet Decoder for Compatibility)

Revision Level
A = Current Revision Level

Standard
S = Standard
A = Special #1
B = Special #2
Etc.....

Heat Exchanger Options
C = Copper Coax w/Coated Air Coil
N = Cupro-Nickel Coax w/Coated Air Coil
D = Copper Coax w/Coated Air Coil & Insulated Tubing
E = Cupro-Nickel Coax w/Coated Air Coil & Insulated Tubing
F = Copper Coax w/Non-Coated Air Coil & Insulated Tubing
G = Cupro-Nickel Coax w/Non-Coated Air Coil & Insulated Tubing
L = Copper Coax w/Non-Coated Air Coil
M = Cupro-Nickel Coax w/Non-Coated Air Coil
H = Copper, RV Energized in Heating w/Coated Air Coil (Replacement Only)
J = Cupro-Nickel, RV Energized in Heating w/Coated Air Coil

Water Valve & Pump Option
S = No Water valve
M = 2-Way Water Valve (Fail Closed)
N = 2-Way Water Valve (Fail Opened)

AUTO-FLOW REGULATOR (US GPM) CODE

	5/8 SWEAT			7/8 SWEAT		
	UNIT 09	UNIT 12	UNIT 15 & 18	UNIT 24	UNIT 30	UNIT 36
C	1.5					
D	2.0	2.0				
E	2.5	2.5	2.5			
F	3.0	3.0	3.0			
G	3.5	3.5	3.5			
H		4.0	4.0	4.0		
J		5.0	5.0	5.0	5.0	
K			6.0	6.0	6.0	6.0
L			7.0	7.0	7.0	7.0
M				8.0	8.0	8.0
N				9.0	9.0	9.0
P					10.0	10.0

S = STANDARD - NO FLOW REGULATOR

817 Chassis

Rev.:01/12/22

General Information

Safety

Warnings, cautions, and notices appear throughout this manual. Read these items carefully before attempting any installation, service, or troubleshooting of the equipment.

DANGER: Indicates an immediate hazardous situation, which if not avoided will result in death or serious injury. DANGER labels on unit access panels must be observed.

WARNING: Indicates a potentially hazardous situation, which if not avoided could result in death or serious injury.

CAUTION: Indicates a potentially hazardous situation or an unsafe practice, which if not avoided could result in minor or moderate injury or product or property damage.

NOTICE: Notification of installation, operation, or maintenance information, which is important, but which is not hazard-related.

! WARNING! !

WARNING! Verify refrigerant type before proceeding. Units are shipped with R-410A (EarthPure®) refrigerants. The unit label will indicate which refrigerant is provided. The EarthPure® Application and Service Manual should be read and understood before attempting to service refrigerant circuits with R-410A.

! WARNING! !

WARNING! To avoid the release of refrigerant into the atmosphere, the refrigerant circuit of this unit must be serviced only by technicians who meet local, state, and federal proficiency requirements.

! WARNING! !

WARNING! The installation of water-source heat pumps and all associated components, parts, and accessories which make up the installation shall be in accordance with the regulations of ALL authorities having jurisdiction and **MUST** conform to all applicable codes. It is the responsibility of the installing contractor to determine and comply with ALL applicable codes and regulations.

! WARNING! !

WARNING! All refrigerant discharged from this unit must be recovered **WITHOUT EXCEPTION**. Technicians must follow industry accepted guidelines and all local, state, and federal statutes for the recovery and disposal of refrigerants. If a compressor is removed from this unit, refrigerant circuit oil will remain in the compressor. To avoid leakage of compressor oil, refrigerant lines of the compressor must be sealed after it is removed.

! CAUTION! !

CAUTION! To avoid equipment damage, **DO NOT** use these units as a source of heating or cooling during the construction process. The mechanical components and filters can quickly become clogged with construction dirt and debris, which may cause system damage and void product warranty.

Inspection - Upon receipt of the equipment, carefully check the shipment against the bill of lading. Make sure all units have been received. Inspect the packaging of each unit, and inspect each unit for damage. Insure that the carrier makes proper notation of any shortages or damage on all copies of the freight bill and completes a common carrier inspection report. Concealed damage not discovered during unloading must be reported to the carrier within 15 days of receipt of shipment. If not filed within 15 days, the freight company can deny the claim without recourse. Note: It is the responsibility of the purchaser to file all necessary claims with the carrier. Notify your equipment supplier of all damage within fifteen (15) days of shipment.

Storage - Equipment should be stored in its original packaging in a clean, dry area. Store chassis in an upright position at all times. Stack units at a maximum of 2 units high.

Unit Protection - Cover units on the job site with either the original packaging or an equivalent protective covering. In areas where painting, plastering, and/or spraying has not been completed, all due precautions must be taken to avoid physical damage to the units and contamination by foreign material. Physical damage and contamination may prevent proper start-up and may result in costly equipment clean-up.

Examine all pipes, fittings, and valves before installing any of the system components. Remove any dirt or debris found in or on these components.

Prior to flushing risers with water, be sure that the temperature in building will always be above freezing.

Pre-Installation - Installation, Operation, and Maintenance instructions are provided with each unit. The installation site chosen should include adequate service clearance around the unit. Before unit start-up, read all manuals and become familiar with the unit and its operation. Thoroughly check the system before operation. Check that you have all kits and options required before starting. **Verify electrical service to cabinet is adequate for new chassis. See electrical data. Upgrade service if it is needed.**

Prepare chassis for installation as follows:

1. Verify refrigerant tubing is free of kinks or dents and that it does not touch other unit components.
2. Inspect all electrical connections. Connections must be clean and tight at the terminals.
3. Remove compressor shipping clips, bracket, or screws. See chassis pre-installation section for instructions.
4. If chassis is not installed in cabinet, store in original carton.

! WARNING! !

WARNING! Polyolester Oil, commonly known as POE oil, is a synthetic oil used in many refrigeration systems including those with HFC-410A refrigerant. POE oil, if it ever comes in contact with PVC or CPVC piping, may cause failure of the PVC/CPVC. PVC/CPVC piping should never be used as supply or return water piping with water source heat pump products containing HFC-410A as system failures and property damage may result.

! CAUTION! !

CAUTION! DO NOT store or install units in corrosive environments or in locations subject to temperature or humidity extremes (e.g., attics, garages, rooftops, etc.). Corrosive conditions and high temperature or humidity can significantly reduce performance, reliability, and service life. Always move and store units in an upright position. Tilting units on their sides will cause equipment damage.

! CAUTION! !

CAUTION! CUT HAZARD - Failure to follow this caution may result in personal injury. Sheet metal parts may have sharp edges or burrs. Use care and wear appropriate protective clothing, safety glasses and gloves when handling parts and servicing heat pumps.

817 Chassis

Rev.:01/12/22

Cabinet and Chassis Pre-Installation and Chassis Installation

⚠ CAUTION! ⚠

CAUTION! ALL WORK MUST BE PERFORMED BY A LICENSED SERVICE TECHNICIAN.

⚠ WARNING! ⚠

WARNING! DISCONNECT AND LOCKOUT ELECTRICAL POWER TO CABINET.

Cabinet Pre-Installation of Chassis

1. Shutoff and lockout unit power at main panel.
2. Close water shutoffs, disconnect hoses at chassis.
3. Disconnect electrical connection to chassis.
4. When installing a TRM chassis or an 817 chassis with control option code P go to the cabinet control box to verify the presence of a blue wire between pin 4 of the twelve pin Molex connector and pin 2 of the nine pin Molex connector. If this wire is not present add it prior to unit start up. Two blue wires are provided in the bag containing the unit installation manual. Select the blue wire that has the appropriate connectors on both ends to mate with the twelve and nine pin Molex's. Discard the unused blue wire. See this on the unit wiring diagram.
5. Remove old chassis.
6. Model 20's will require controls blower housing or deck and housing to be replaced (optional other models), see instructions with kit. (79S004 Series)

⚠ CAUTION! ⚠

CAUTION! CLIMATEMASTER IS NOT RESPONSIBLE OR LIABLE FOR ANY DAMAGE DUE TO WATER LEAKS

7. 816 style cabinets with "P" style controls only require a wire harness conversion kit. 816 style cabinets with "P" controls were offered with a singular 9-pin harness and utilized a gray FP1 thermistor for freeze protection in heating mode only. The later generation cabinets introduced a 6-pin wire harness combined with a 9-pin harness which added a violet FP2 thermistor for freeze protection during both heating and cooling modes of operation. The S11S0084N01 controls conversion kit includes a combination 12/9/6-pin wire harness and violet FP2 thermistor which is compatible with the current 817 and TRM replacement chassis products. See wire diagram that comes with the S11S0084N01 for details on installation of the conversion wire harness.

8. Revisions M and higher will have hose connection. Revisions A-L had hard unions, water connection must be reworked for hose connection. Use adapter kit 29S0019 series or repipe using new ball valve shutoffs. Any new piping cannot interfere with chassis.
9. **Note: Any water tubing modifications behind shutoff will require draining riser. Pressure test before refilling water.**
10. Attach hoses, NPT threaded end to cabinet.
11. Some high voltage cabinets will require wire harness (shipped with chassis). Open control box to connect, run wires through grommets hole in bottom of box, molex end hanging down. Close electrical box.

Note: Old A-Mode style electrical connectors should not be reused.
12. Cabinets that controls were changed require low voltage thermostat. Also old cabinets that energized RV for heating and new replacement has RV for cooling will require thermostat to send O signal. Replace thermostat if required.
13. Clean interior of cabinet.
14. Check drain pan is draining freely.

Chassis Pre-Installation

1. Check chassis data plate. Verify chassis is correct (Both size and voltage) for cabinet.

Old Chassis	New Chassis
10	817 09
15	817 12
20	TRM 18
28	817/TRM 24 or 30
30	817/TRM 30
36	817/TRM 36

2. Check for any shipping or handling damage. Make repairs or adjustments.
3. Verify refrigerant tubing is free of kinks or dents and that it does not touch other unit components.
4. Inspect all electrical connections. Connections must be clean and tight at the terminals.
5. If your model has 24 volt motorized water valve, locate black wire from wire nut, remove plastic covering from terminal and push into position 6 of 9 pin molex. (See View A).
6. Install hose adaptor kit 29S0019 Series if required.

Chassis Installation

1. Position chassis partway into cabinet.
2. Connect hoses, swivel end to chassis. Check washer is inside swivel hand tighten.
3. Purge air (if model has motorized water valve - manually open) from chassis. Hand tighten hoses plus 1/8 turn.
4. Slide into cabinet. Do not pinch hoses, adjust if required.
5. Connect electrical molex. 1, 2, or 3, depending on your model.
6. Open both water shutoffs. Check for any water leaks. Repair if needed
7. Attach upper blockoff. Blockoff should overlap air coil so no air can bypass coil. Seal if required.
8. Turn on electrical power.
9. Check unit operation.
10. Reinstall front panel. Panel or chassis sheet metal may require field modifications for attaching.

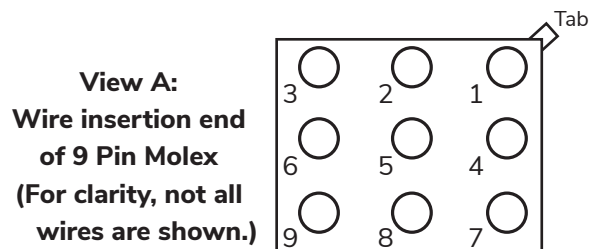

817 Chassis

Rev.:01/12/22

Electrical Data and 817 Series Wiring Diagram Matrix

Electrical Data

Model	Voltage Code	Voltage	Min/Max Voltage	Compressor	
				RLA	LRA
817 09	G	208-230/60/1	197/254	4.7	23
817 12	G	208-230/60/1	197/254	5.3	30
TRM 18	G	208-230/60/1	197/254	6.6	33
817/TRM 24	G	208-230/60/1	197/254	12.8	58.3
817/TRM 30	G	208-230/60/1	197/254	12.8	64
817/TRM 36	G	208-230/60/1	197/254	14.1	77
817 09	E	265/60/1	239/292	3.5	22.0
817 12	E	265/60/1	239/292	4.2	22.0
TRM 18	E	265/60/1	239/292	5.6	28.0
817/TRM 24	E	265/60/1	239/292	13.5	47.5
817/TRM 30	E	265/60/1	239/292	13.5	52.0
817/TRM 36	E	265/60/1	239/292	14.8	62.8

VERIFY ELECTRICAL SERVICE IS ADEQUATE FOR NEW CHASSIS.

817 Series Wiring Diagram Matrix

All diagrams can be located online at climatemaster.com using the part numbers presented below

Chassis

Model	Refrigerant	Wiring Diagram Part Number	Electrical	Control	Agency
817 09-36	EarthPure® (HFC-410A)	96B0036N18	208-230/1/60, 265/1/60	"P" Controls (Standard/FC MWV)	ETL
		96B0036N19		"P" Controls (FO MWV)	
		96B0036N07		"S" Controls	
		96B0036N17		"M" Controls	

Wiring Diagrams - 96B0036N18 - P Controls Standard/Fail Closed MWV

TITLE Size 09 - 36 "G", "E" & "V" Voltage, CXM or DXM, w/ "P" Controls		PCN NO. 14-0014	DATE 01/21/14		DRAWING NO. 96B0036N18	REV. A	
LEGEND: _____ Factory Line Voltage Wiring _____ Factory Low Voltage Wiring - - - - - Optional Wiring - - - - - Option Box High Pressure Switch Loss of Charge Switch Sensor, Water Coil Freeze Protection - - - - - Field Low Voltage		RV Solenoid Coil RELAY/ACTUATOR COIL CAPACITOR * OPTIONAL ITEMS BUTT CONNECT Splice Cap Wire Nut		CRC Compressor Run Capacitor COMPR Compressor ES Water Valve End Switch HP High Pressure Switch HPWS High Pressure Water Switch FP1 Sensor, Low Temp Protection Water Coil FP2 Sensor, Low Temp Protection Air Coil LOC Loss of Charge RAS Remote Air Sensor RVS Reversing Valve Solenoid SAC Start Assist Capacitor TBLK Terminal Block MWV Motorized Water Valve		NOTES: 1. Ext. Compr. Overload on Sizes 09, 10, 12 & 15 Only. 2. Used with TRM24/30/36 only. 3. WHEN THERE IS NO MWV END SWITCH, YELLOW JUMPER MUST BE ATTACHED AT PINS 3 & 4. 4. Optional wiring for Remote Air Sensor. Connects to 9-Pin Quick Connect In Cabinet, For Surface mounted TSTAT. 5. SPLICE CAP THE END SWITCH WIRES ON NORMALLY OPEN MOTORIZED WATER VALVE. 6. FOR USE WITH TACO PUMP. RED/YEL AND WHT WIRES ARE INSIDE PUMP WIRING BOX. 7. START ASSIST CAPACITOR FOR SIZES 9 -18 ONLY 8. Field connect blue wire, shipped loose with chassis. Part No. 11B0023N01.	

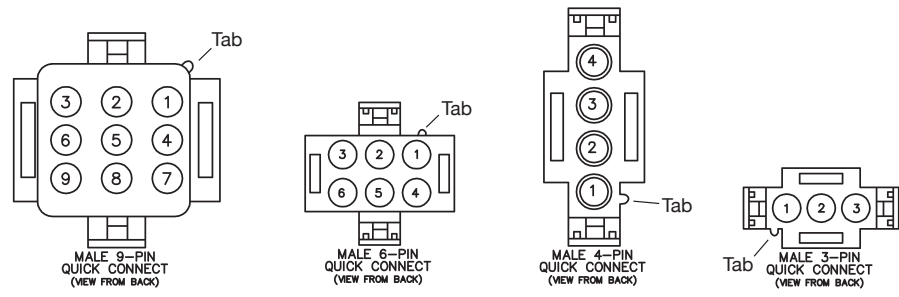
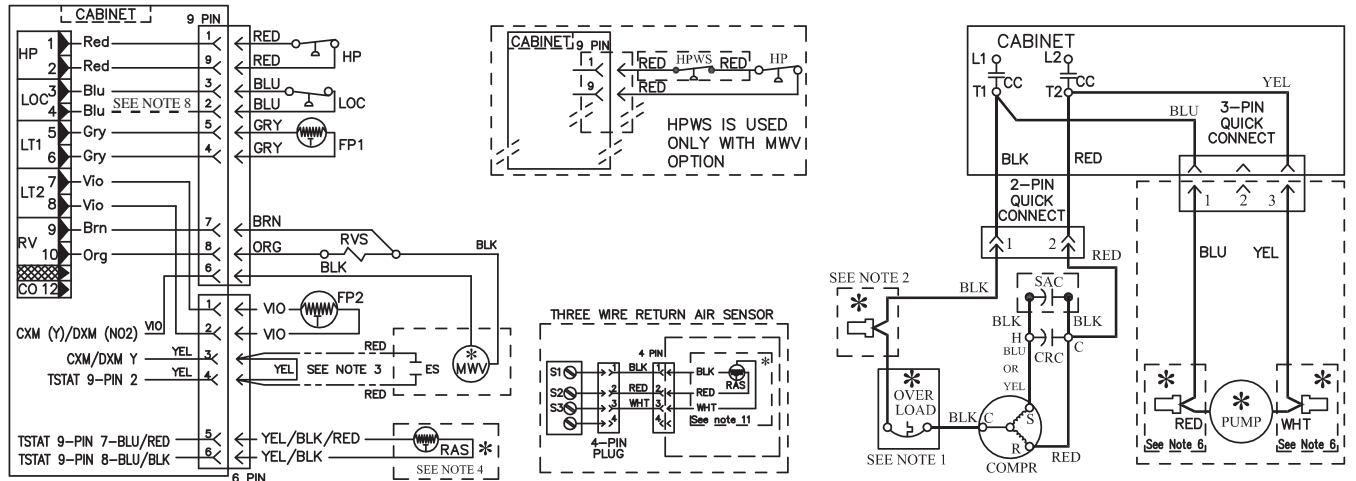







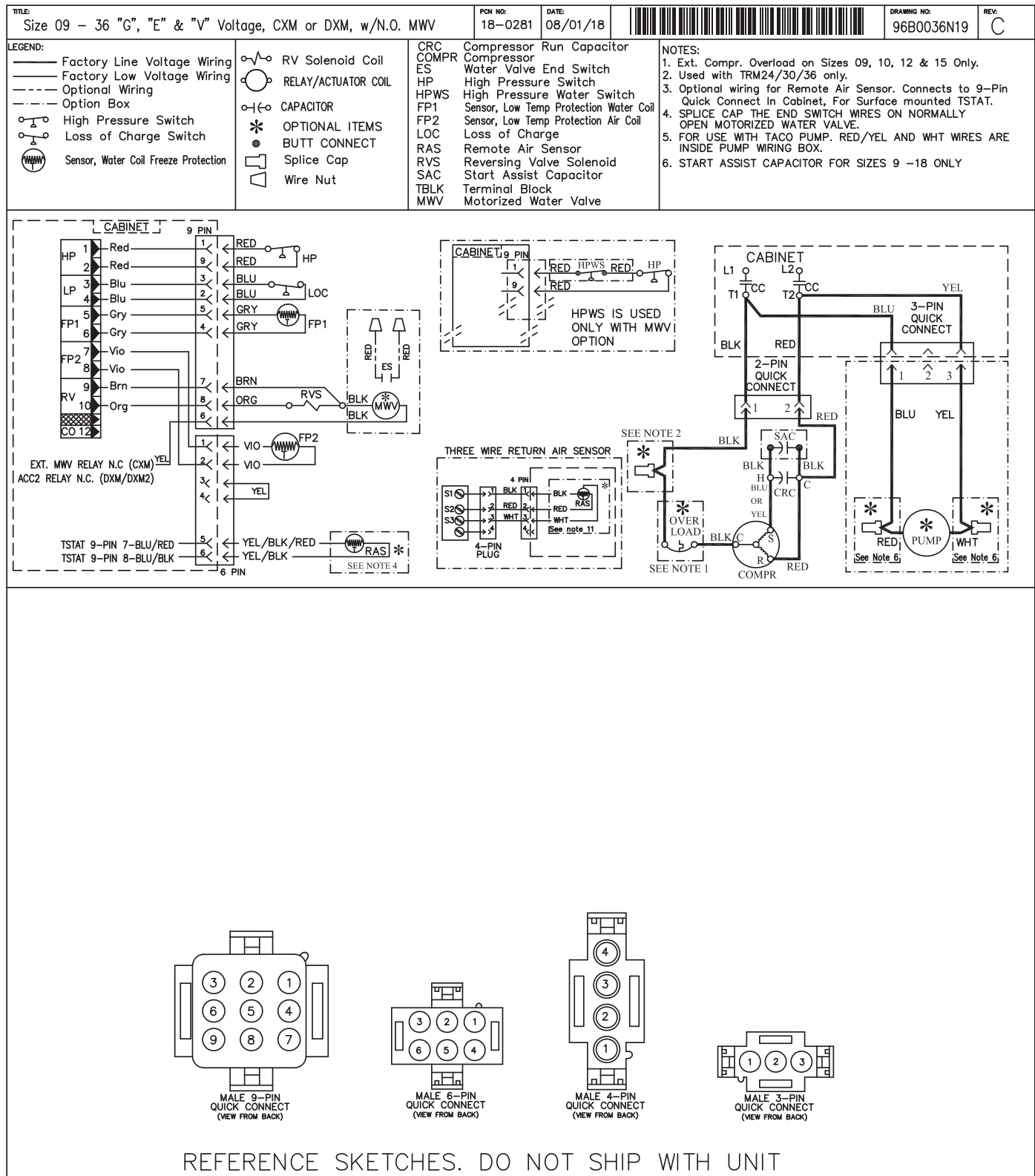

817 Chassis

Rev.:01/12/22

Wiring Diagrams - 96B0036N19 - P Controls Fail-Open MWV



Wiring Diagrams - 96B0036N07 - S Controls

TITLE: 81709 - 36 "G" & "E" Voltage, "LINE VOLTAGE" "S" Controls		PON NO: 16-0130	DATE: 03/18/16		DRAWING NO: 96B0036N07	REV: K	
LEGEND: ——— Factory Line Voltage Wiring - - - - - Factory Low Voltage Wiring - - - - - Optional Wiring - - - - - Option Box  High Pressure Switch  Loss of Charge Switch  FREEZE STAT		 RV Solenoid Coil  RELAY/ACTUATOR COIL  CAPACITOR * OPTIONAL ITEMS  MULTI SPLICE CONNECTOR		CRC Compressor Run Capacitor COMPR Compressor FS FREEZE STAT HP High Pressure Switch HPWS High Pressure Water Switch LTS LOW TEMP SWITCH LOC Loss of Charge LOR LOCK OUT RELAY RVS Reversing Valve Solenoid SAC Start Assist Capacitor TBLK Terminal Block		NOTES: 1. Ext. Compr. Overload on Sizes 09, 12, 15 & 18 Only. 2. Used with 81724/30/36 COMPR PLUG only. 3. START ASSIST CAPACITOR FOR SIZES 9-18 ONLY	

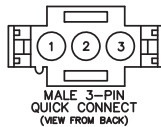
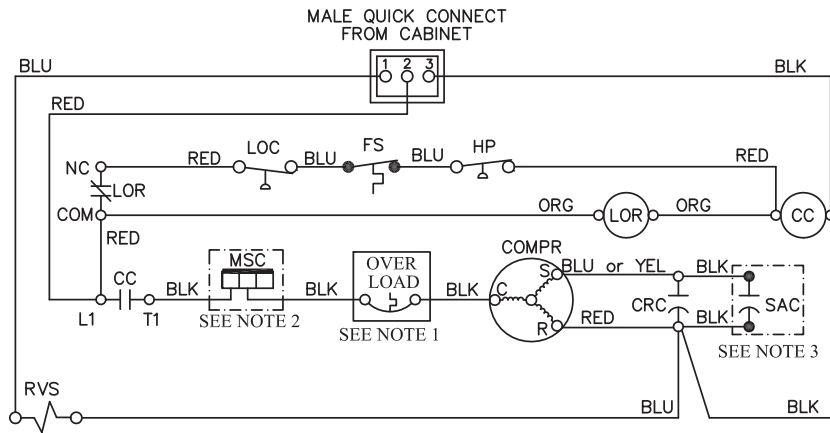









REFERENCE SKETCHES. DO NOT SHIP WITH UNIT

817 Chassis

Rev.:01/12/22

Wiring Diagrams - 69358802 - M Controls

TITLE: Size 09 - 36 "G" & "E" Voltage, CMC or ELEC MECH "M" Controls		PCN NO: 21-0095	DATE: 03/02/21		DRAWING NO.: 96B0036N17	REV.: C
LEGEND: — Factory Line Voltage Wiring - - - Factory Low Voltage Wiring - - - - - Optional Wiring [] Option Box  High Pressure Switch  Loss of Charge Switch  Sensor, Water Coil Freeze Protection  RV Solenoid Coil		 RELAY/ACTUATOR COIL  CAPACITOR * OPTIONAL ITEMS ● BUTT CONNECT  MULTI SPLICE CONNECTOR  Wire Nut		CRC Compressor Run Capacitor COMPR Compressor HP High Pressure Switch HPWS High Pressure Water Switch LTS LOW TEMP SWITCH LOC Loss of Charge RVS Reversing Valve Solenoid SAC Start Assist Capacitor TBLK Terminal Block MWV Motorized Water Valve		NOTES: 1. Ext. Compr. Overload on Sizes 09, 12, 15 & 18 Only. 2. Used with TRM24/30/36 COMPR PLUG only.

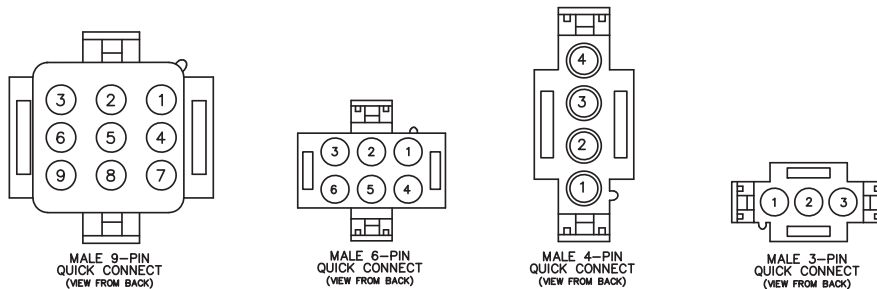
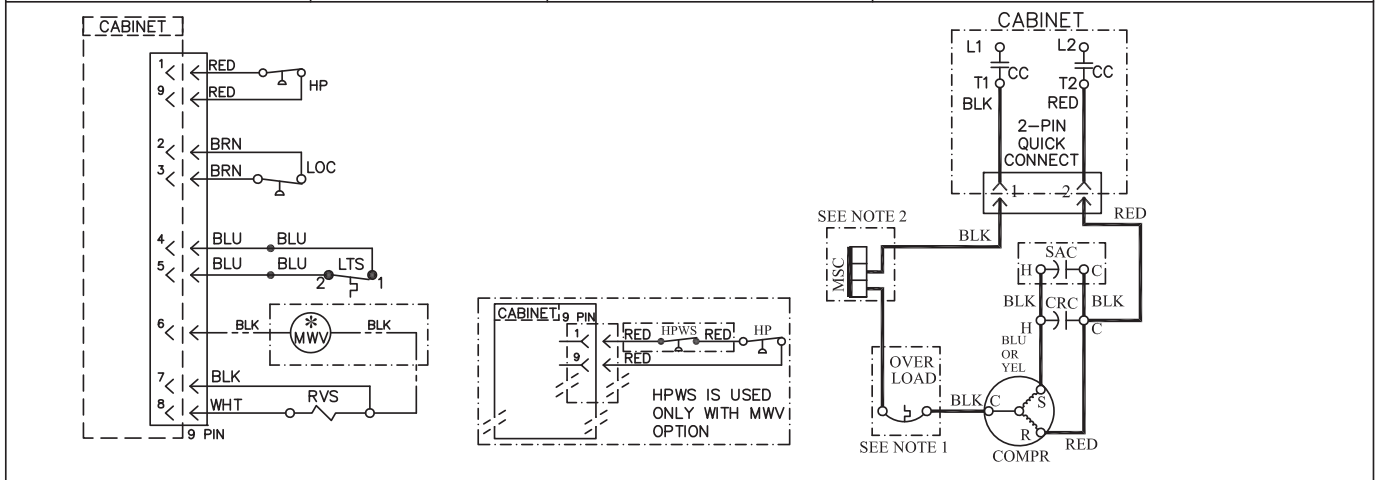

Preventive Maintenance

Water Coil Maintenance -

(Direct ground water applications only)

If the system is installed in an area with a known high mineral content (125 P.P.M. or greater) in the water, it is best to establish a periodic maintenance schedule with the owner so the coil can be checked regularly. Consult the well water applications section of this manual for a more detailed water coil material selection. Should periodic coil cleaning be necessary, use standard coil cleaning procedures, which are compatible with the heat exchanger material and copper water lines. Generally, the more water flowing through the unit, the less chance for scaling. Therefore, 1.5 gpm per ton [2.0 l/m per kW] is recommended as a minimum flow. Minimum flow rate for entering water temperatures below 50°F [10°C] is 2.0 gpm per ton [2.6 l/m per kW].

Water Coil Maintenance -

(All other water loop applications)

Generally water coil maintenance is not needed for closed loop systems. However, if the piping is known to have high dirt or debris content, it is best to establish a periodic maintenance schedule with the owner so the water coil can be checked regularly. Dirty installations are typically the result of deterioration of iron or galvanized piping or components in the system. Open cooling towers requiring heavy chemical treatment and mineral buildup through water use can also contribute to higher maintenance. Should periodic coil cleaning be necessary, use standard coil cleaning procedures, which are compatible with both the heat exchanger material and copper water lines. Generally, the more water flowing through the unit, the less chance for scaling. However, flow rates over 3 gpm per ton (3.9 l/m per kW) can produce water (or debris) velocities that can erode the heat exchanger wall and ultimately produce leaks.

Filters - Filters must be clean to obtain maximum performance. Filters should be inspected every month under normal operating conditions and be replaced when necessary. Units should never be operated without a filter.

Washable, high efficiency, electrostatic filters, when dirty, can exhibit a very high pressure drop for the fan motor and reduce air flow, resulting in poor performance. It is especially important to provide consistent washing of these filters (in the opposite direction of the normal air flow) once per month using a high pressure wash similar to those found at self-serve car washes.

Condensate Drain - In areas where airborne bacteria may produce a "slimy" substance in the drain pan, it may be necessary to treat the drain pan chemically with an algaecide approximately every three months to minimize the problem. The condensate pan may also need to be cleaned periodically to insure indoor air quality. The condensate drain can pick up lint and dirt, especially with dirty filters. Inspect the drain twice a year to avoid the possibility of plugging and eventual overflow.

Compressor - Conduct annual amperage checks to ensure that amp draw is no more than 10% greater than indicated on the serial plate data.

Fan Motors - All units have lubricated fan motors. Fan motors should never be lubricated unless obvious, dry operation is suspected. Periodic maintenance oiling is not recommended, as it will result in dirt accumulating in the excess oil and cause eventual motor failure. Conduct annual dry operation check and amperage check to insure amp draw is no more than 10% greater than indicated on serial plate data.

Air Coil - The air coil must be cleaned to obtain maximum performance. Check once a year under normal operating conditions and, if dirty, brush or vacuum clean. Care must be taken not to damage the aluminum fins while cleaning.
CAUTION: Fin edges are sharp.

Cabinet - Check inside cabinet once a year. Gently brush or vacuum clean if needed. Do not tear insulation.

Refrigerant System - To maintain sealed circuit integrity, do not install service gauges unless unit operation appears abnormal. Reference the operating charts for pressures and temperatures. Verify that air and water flow rates are at proper levels before servicing the refrigerant circuit.

817 Chassis

Rev.:01/12/22

Start-up Log Sheet

Installer: Complete unit and system checkout and follow unit start-up procedures in the IOM. Use this form to record unit information, temperatures and pressures during start-up. Keep this form for future reference.

Job Name: _____ **Street Address:** _____

Old Chassis Model Number: _____ **Serial Number:** _____

Old Cabinet Model Number: _____ **Serial Number:** _____

New Chassis Model Number: _____ **Serial Number:** _____

Unit Location in Building: _____

Date: _____ **Sales Order No:** _____

Deck Kit Number: _____ (If ordered)

In order to minimize troubleshooting and costly system failures, complete the following checks and data entries before the system is put into full operation.

Temperatures: **F or C**

Antifreeze: _____ %

Pressures: **PSIG or kPa**

Type: _____

	Cooling Mode	Heating Mode
Return-Air Temperature	DB	WB DB
Supply-Air Temperature	DB	WB DB
Temperature Differential		
Entering Fluid Temperature		
Leaving Fluid Temperature		
Temperature Differential		
Water Coil Heat Exchanger (Water Pressure IN)		
Water Coil Heat Exchanger (Water Pressure OUT)		
Pressure Differential		
Flow Rate GPM (l/s)		
Compressor		
Amps		
Volts		
Discharge Line Temperature		
Motor		
Amps		
Volts		

Allow unit to run 15 minutes in each mode before taking data.

Do not connect gauge lines

Functional Troubleshooting

For Cabinets with CXM or DXM Boards

Fault	Htg	Clg	Possible Cause	Solution	
Main power problems	X	X	Green Status LED Off	Check line voltage circuit breaker and disconnect.	
				Check for line voltage between L1 and L2 on the contactor.	
				Check for 24VAC between R and C on CXM2/DXM2	
HP Fault Code 2 High Pressure		X	Reduced or no water flow in cooling	Check pump operation or valve operation/setting. Check water flow adjust to proper flow rate.	
			Water Temperature out of range in cooling	Bring water temp within design parameters.	
		X		Reduced or no air flow in heating	Check for dirty air filter and clean or replace. Check fan motor operation and airflow restrictions. Dirty Air Coil- construction dust etc. Too high of external static. Check static vs blower table.
	Air temperature out of range in heating			Bring return air temp within design parameters.	
	Overcharged with refrigerant			Check superheat/subcooling vs typical operating condition table.	
	Bad HP Switch			Check switch continuity and operation. Replace.	
	LP/LOC Fault Code 3 Low Pressure / Loss of Charge	X	X	Insufficient charge	Check for refrigerant leaks
Compressor pump down at start-up				Check charge and start-up water flow.	
LT1 Fault Code 4 Water coil low temperature limit	X		Reduced or no water flow in heating	Check pump operation or water valve operation/setting. Plugged strainer or filter. Clean or replace.. Check water flow adjust to proper flow rate.	
			Inadequate antifreeze level	Check antifreeze density with hydrometer.	
			Improper temperature limit setting (30°F vs 10°F [-1°C vs -2°C])	Clip JW3 jumper for antifreeze (10°F [-12°C]) use.	
	X	X	Water Temperature out of range	Bring water temp within design parameters.	
			Bad thermistor	Check temp and impedance correlation per chart	
LT2 Fault Code 5 Air coil low temperature limit		X	Reduced or no air flow in cooling	Check for dirty air filter and clean or replace. Check fan motor operation and airflow restrictions. Too high of external static. Check static vs blower table.	
			Air Temperature out of range	Too much cold vent air? Bring entering air temp within design parameters.	
	X	X	Improper temperature limit setting (30°F vs 10°F [-1°C vs -12°C])	Normal airside applications will require 30°F [-1°C] only.	
			Bad thermistor	Check temp and impedance correlation per chart.	
Condensate Fault Code 6	X	X	Blocked drain	Check for blockage and clean drain.	
			Improper trap	Check trap dimensions and location ahead of vent. Check for piping slope away from unit. Check slope of unit toward outlet. Poor venting. Check vent location.	
			Poor drainage	Check for moisture shorting to air coil.	
	X	X	Moisture on sensor	Replace air filter.	
			Plugged air filter	Find and eliminate restriction. Increase return duct and/or grille size.	
			Restricted Return Air Flow	Check power supply and 24VAC voltage before and during operation. Check power supply wire size. Check compressor starting. Need hard start kit? Check 24VAC and unit transformer tap for correct power supply voltage.	
				Check power supply voltage and 24VAC before and during operation. Check 24VAC and unit transformer tap for correct power supply voltage.	
Over/Under Voltage Code 7 (Auto resetting)	X	X	Under Voltage	Check for poor air flow or overcharged unit.	
			Over Voltage		
Unit Performance Sentinel Code 8	X		Heating mode LT2>125°F [52°C]		
			Cooling Mode LT1>125°F [52°C] OR LT2< 40°F [4°C])	Check for poor water flow, or air flow.	
Swapped Thermistor Code 9	X	X	LT1 and LT2 swapped	Reverse position of thermistors	
No Fault Code Shown	X	X	No compressor operation	See "Only Fan Operates".	
			Compressor overload	Check and replace if necessary.	
			Control board	Reset power and check operation.	
Unit Short Cycles	X	X	Dirty air filter	Check and clean air filter.	
			Unit in "test mode"	Reset power or wait 20 minutes for auto exit.	
			Unit selection	Unit may be oversized for space. Check sizing for actual load of space.	
			Compressor overload	Check and replace if necessary	
			Thermostat position	Ensure thermostat set for heating or cooling operation.	
Only Fan Runs	X	X	Unit locked out	Check for lockout codes. Reset power.	
			Compressor Overload	Check compressor overload. Replace if necessary.	
			Thermostat wiring	Check thermostat wiring at heat pump. Jumper Y and R for compressor operation in test mode.	
			Thermostat wiring	Check G wiring at heat pump. Jumper G and R for fan operation	
Only Compressor Runs	X	X	Fan motor relay	Jumper G and R for fan operation. Check for Line voltage across BR contacts. Check fan power enable relay operation (if present).	
			Fan motor	Check for line voltage at motor. Check capacitor.	
			Thermostat wiring	Check thermostat wiring at heat pump. Jumper Y and R for compressor operation in test mode	
		X		Reversing valve	Set for cooling demand and check 24VAC on RV coil and at CXM2/DXM2 board. If RV is stuck, run high pressure up by reducing water flow and while operating engage and disengage RV coil voltage to push valve.
				Thermostat setup	Check for 'O' RV setup not 'B'.
Thermostat wiring	Check O wiring at heat pump. Jumper O and R for RV coil 'click'.				
Unit Doesn't Operate in Cooling		X	Thermostat wiring	Put thermostat in cooling mode. Check 24 VAC on O (check between C and O); check for 24 VAC on W (check between W and C). There should be voltage on O, but not on W. If voltage is present on W, thermostat may be bad or wired incorrectly.	

817 Chassis

Rev.:01/12/22

Performance Troubleshooting

Performance Troubleshooting	Htg	Clg	Possible Cause	Solution
Insufficient capacity/ Not cooling or heating	X	X	Dirty filter	Replace or clean.
	X		Reduced or no air flow in heating	Check for dirty air filter and clean or replace.
				Check fan motor operation and airflow restrictions.
				Too high of external static. Check static vs. blower table.
		X	Reduced or no air flow in cooling	Check for dirty air filter and clean or replace.
				Check fan motor operation and airflow restrictions.
				Too high of external static. Check static vs. blower table.
	X	X	Leaky duct work	Check supply and return air temperatures at the unit and at distant duct registers if significantly different, duct leaks are present.
	X	X	Low refrigerant charge	Check superheat and subcooling per chart.
	X	X	Restricted metering device	Check superheat and subcooling per chart. Replace.
		X	Defective reversing valve	Perform RV touch test.
X	X	Thermostat improperly located	Check location and for air drafts behind stat.	
X	X	Unit undersized	Recheck loads & sizing. Check sensible clg. load and heat pump capacity.	
X	X	Scaling in water heat exchanger	Perform scaling check and clean if necessary.	
X	X	Inlet water too hot or too cold	Check load, loop sizing, loop backfill, ground moisture.	
High Head Pressure	X		Reduced or no air flow in heating	Check for dirty air filter and clean or replace.
				Check fan motor operation and air flow restrictions.
				Too high of external static. Check static vs. blower table.
		X	Reduced or no water flow in cooling	Check pump operation or valve operation/setting.
	Check water flow. Adjust to proper flow rate.			
		X	Inlet water too hot	Check load, loop sizing, loop backfill, ground moisture.
	X		Air temperature out of range in heating	Bring return air temperature within design parameters.
		X	Scaling in water heat exchanger	Perform scaling check and clean if necessary.
X	X	Unit overcharged	Check superheat and subcooling. Re-weigh in charge.	
X	X	Non-condensables in system	Vacuum system and re-weigh in charge.	
X	X	Restricted metering device.	Check superheat and subcooling per chart. Replace.	
Low Suction Pressure	X		Reduced water flow in heating.	Check pump operation or water valve operation/setting.
				Plugged strainer or filter. Clean or replace.
				Check water flow. Adjust to proper flow rate.
	X		Water temperature out of range.	Bring water temperature within design parameters.
		X	Reduced air flow in cooling.	Check for dirty air filter and clean or replace.
				Check fan motor operation and air flow restrictions.
			Too high of external static. Check static vs. blower table.	
	X	Air temperature out of range	Too much cold vent air? Bring entering air temperature within design parameters.	
X	X	Insufficient charge	Check for refrigerant leaks.	
Low Discharge Air Temperature in Heating	X		Too high of air flow	Check fan motor speed selection and air flow chart.
	X		Poor performance	See 'Insufficient Capacity'
High humidity		X	Too high of air flow	Check fan motor speed selection and airflow chart.
		X	Unit oversized	Recheck loads & sizing. Check sensible clg load and heat pump capacity.

Troubleshooting Form

Customer: _____ Loop Type: _____ Startup Date: _____

Model #: _____ Serial #: _____ Antifreeze Type & %: _____

Complaint: _____

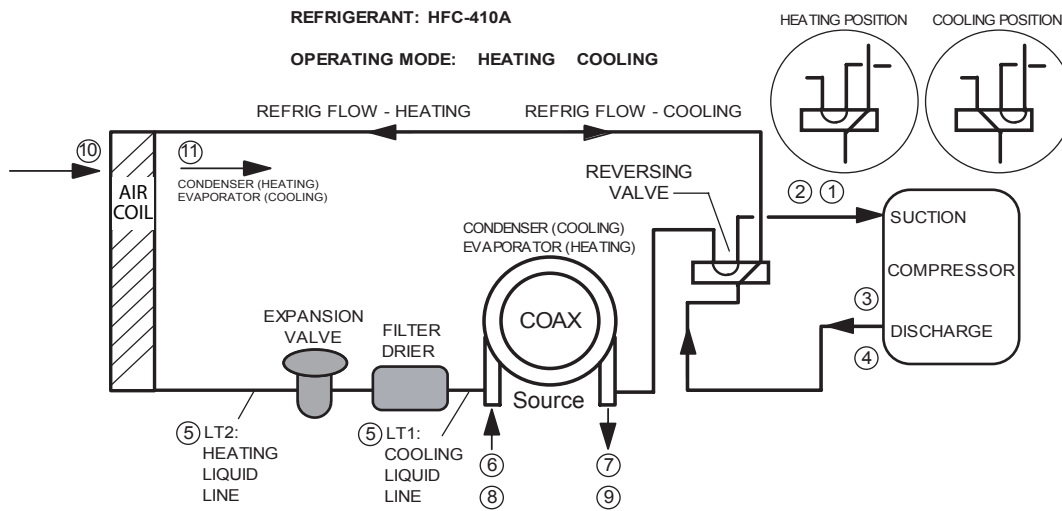

Description	Heating	Cooling	Notes
Voltage			
Compressor Amps			
1 Suction Temp			
2 Suction Press			
2a Saturation Temp			
2b Superheat			
3 Discharge Temp			
4 Discharge Press			
4a Saturation Temp			
4b Subcooling			
5 Liquid Line Temp			
6 Source Water In Tmp			
7 Source Water Out Tmp			Temp Diff. =
8 Source Water In Pres			
9 Source Water Out Pres			
9a Press Drop			
9b Flow Rate			
10 Return Air Temp			
11 Supply Air Temp			

Heat of Extraction (Absorption) or Heat of Rejection:

Fluid Factor: (for Btuh)
500 (Water); 485 (Antifreeze)

Fluid Factor: (for kW)
4.18 (Water); 4.05 (Antifreeze)

HE or HR =

_____ Flow Rate x _____ Temp. Diff x _____ Fluid Factor

Superheat = Suction temperature - suction saturation temp. = _____ (deg F)

Subcooling = Discharge saturation temp. - liquid line temp. = _____ (deg F)

Note: Never connect refrigerant gauges during startup procedures. Conduct water-side analysis using P/T ports to determine water flow and temperature difference. If water-side analysis shows poor performance, refrigerant troubleshooting may be required. Connect refrigerant gauges as a last resort.

Warranty



**CLIMATE MASTER, INC.
LIMITED EXPRESS WARRANTY/ LIMITATION OF REMEDIES AND LIABILITY**

It is expressly understood that unless a statement is specifically identified as a warranty, statements made by Climate Master, Inc., a Delaware corporation, ("CM") or its representatives, relating to CM's products, whether oral, written or contained in any sales literature, catalog or any other agreement, are not express warranties and do not form a part of the basis of the bargain, but are merely CM's opinion or commendation of CM's products.

EXCEPT AS SPECIFICALLY SET FORTH HEREIN, THERE IS NO EXPRESS WARRANTY AS TO ANY OF CM'S PRODUCTS. CM MAKES NO WARRANTY AGAINST LATENT DEFECTS. CM MAKES NO WARRANTY OF MERCHANTABILITY OF THE GOODS OR OF THE FITNESS OF THE GOODS FOR ANY PARTICULAR PURPOSE.

GRANT OF LIMITED EXPRESS WARRANTY. CM warrants CM products purchased and retained in the United States of America and Canada to be free from defects in material and workmanship under normal use and maintenance as follows: (1) All complete air conditioning, heating and/or heat pump units built or sold by CM for twelve (12) months from date of unit start up or eighteen (18) months from date of shipment (from factory), whichever comes first; (2) Repair and replacement parts, which are not supplied under warranty, for ninety (90) days from date of shipment (from factory). All parts must be returned to CM's factory in Oklahoma City, Oklahoma, freight prepaid, no later than sixty (60) days after the date of the failure of the part; if CM determines the part to be defective and within CM's Limited Express Warranty, CM shall, when such part has been either replaced or repaired, return such to a factory recognized dealer, contractor or service organization, F.O.B. CM's factory, Oklahoma City, Oklahoma, freight prepaid. The warranty on any parts repaired or replaced under warranty expires at the end of the original warranty period.

This warranty does not cover and does not apply to: (1) Air filters, fuses, refrigerant, fluids, oil; (2) Products relocated after initial installation; (3) Any portion or component of any system that is not supplied by CM, regardless of the cause of the failure of such portion or component; (4) Products on which the unit identification tags or labels have been removed or defaced; (5) Products on which payment to CM is or has been in default; (6) Products which have defects or damage which result from improper installation, wiring, electrical imbalance characteristics or maintenance; or are caused by accident, misuse or abuse, fire, flood, alteration or misapplication of the product; (7) Products which have defects or damage which result from a contaminated or corrosive air or liquid supply, operation at abnormal temperatures, or unauthorized opening of refrigerant circuit; (8) Mold, fungus or bacteria damages; (9) Products subjected to corrosion or abrasion; (10) Products manufactured or supplied by others; (11) Products which have been subjected to misuse, negligence or accidents; (12) Products which have been operated in a manner contrary to CM's printed instructions; or (13) Products which have defects, damage or insufficient performance as a result of insufficient or incorrect system design or the improper application of CM's products.

CM is not responsible for: (1) The costs of any fluids, refrigerant or other system components, or associated labor to repair or replace the same, which is incurred as a result of a defective part covered by CM's Limited Express Warranty; (2) The costs of labor, refrigerant, materials or service incurred in removal of the defective part, or in obtaining and replacing the new or repaired part; or, (3) Transportation costs of the defective part from the installation site to CM or of the return of any part not covered by CM's Limited Express Warranty.

Limitation: This Limited Express Warranty is given in lieu of all other warranties. If, notwithstanding the disclaimers contained herein, it is determined that other warranties exist, any such warranties, including without limitation any express warranties or any implied warranties of fitness for particular purpose and merchantability, shall be limited to the duration of the Limited Express Warranty.

LIMITATION OF REMEDIES
In the event of a breach of the Limited Express Warranty, CM will only be obligated at CM's option to repair the failed part or unit or to furnish a new or rebuilt part or unit in exchange for the part or unit which has failed. If after written notice to CM's factory in Oklahoma City, Oklahoma of each defect, malfunction or other failure and a reasonable number of attempts by CM to correct the defect, malfunction or other failure, and the remedy fails of its essential purpose, CM shall refund the purchase price paid to CM in exchange for the return of the sold good(s). Said refund shall be the maximum liability of CM. **THIS REMEDY IS THE SOLE AND EXCLUSIVE REMEDY OF THE BUYER OR THEIR PURCHASER AGAINST CM FOR BREACH OF CONTRACT, FOR THE BREACH OF ANY WARRANTY OR FOR CM'S NEGLIGENCE OR IN STRICT LIABILITY.**

LIMITATION OF LIABILITY
CM shall have no liability for any damages if CM's performance is delayed for any reason or is prevented to any extent by any event such as, but not limited to: any war, civil unrest, government restrictions or restraints, strikes or work stoppages, fire, flood, accident, shortages of transportation, fuel, material, or labor, acts of God or any other reason beyond the sole control of CM. **CM EXPRESSLY DISCLAIMS AND EXCLUDES ANY LIABILITY FOR CONSEQUENTIAL OR INCIDENTAL DAMAGE IN CONTRACT, FOR BREACH OF ANY EXPRESS OR IMPLIED WARRANTY, OR IN TORT, WHETHER FOR CM'S NEGLIGENCE OR AS STRICT LIABILITY.**

OBTAINING WARRANTY PERFORMANCE
Normally, the contractor or service organization who installed the products will provide warranty performance for the owner. Should the installer be unavailable, contact any CM recognized dealer, contractor or service organization. If assistance is required in obtaining warranty performance, write or call:

Climate Master, Inc. • Customer Service • 7300 S.W. 44th Street • Oklahoma City, Oklahoma 73179 (405) 745-6000

NOTE: Some states or Canadian provinces do not allow limitations on how long an implied warranty lasts, or the limitation or exclusions of consequential or incidental damages, so the foregoing exclusions and limitations may not apply to you. This warranty gives you specific legal rights, and you may also have other rights which vary from state to state and from Canadian province to Canadian province.

Please refer to the CM Installation, Operation and Maintenance Manual for operating and maintenance instructions.

Rev.: 11/09



LC083

817 Chassis

Rev.: 01/12/22

NOTES:

817 Chassis

Rev.:01/12/22

Revision History

Date:	Item:	Action:
01/12/22	Added controls conversion kit text to cabinet installation instructions	Added
08/27/21	Updated 2-Way Water Valve descriptions to "Fail Closed". Added new "Fail Opened" option.	Updated
03/25/20	Page 5 updated description for blue LOC wire Page 8 updated diagram	Updated
07/14/16	Logo	Updated
04/19/16	Logo	Updated
04/15/16	Text-Logo	Updated
02/28/14	Text and Wiring Diagrams	Updated
07/12/13	Miscellaneous Items	Updated
11/09/12	POE Oil Warning	Added
11/15/11	Model Nomenclature Cabinet and Chassis Pre-Installation and Chassis Installation.	Updated
01/03/11	Format - All Pages	Updated
07/26/10	Wiring Diagrams	Updated
06/28/10	Start-up Sheet Log	Updated
06/11/10	Format - All Pages	Updated
02/17/10	First Published	



97B0056N02



7300 S.W. 44th Street
Oklahoma City, OK 73179
Phone: 405-745-6000
Fax: 405-745-6058
climatemaster.com

ClimateMaster works continually to improve its products. As a result, the design and specifications of each product at the time for order may be changed without notice and may not be as described herein. Please contact ClimateMaster's Customer Service Department at 1-405-745-6000 for specific information on the current design and specifications. Statements and other information contained herein are not express warranties and do not form the basis of any bargain between the parties, but are merely ClimateMaster's opinion or commendation of its products.