



COMMERCIAL
TRANQUILITY® (SB) COMPACT HIGH-CAPACITY SERIES
**INSTALLATION, OPERATION
& MAINTENANCE MANUAL**

Part#: 97B0150N01 | Revised: December 19, 2024

Models: SB 072-300
60Hz – R-454B



Models:
SB
072-300

Table of Contents

3	Model Nomenclature	42	Electrical Data: Standard
4	Attentions, Cautions, and Warnings	43	Electrical Data: Dual Point Power
6	General Information	45	Electrical: Power and Low Voltage Wiring
9	Minimum Installation Area	46	Electrical: CXM2 Example Wiring Diagram
10	Refrigerant System Servicing	47	Electrical: Low Voltage Wiring
13	Physical Data	49	Electrical: Thermostat Wiring
14	SB072-120 Horizontal Dimensional Data	50	Electrical: External Pump Control
15	SB072-120 with WSE Horizontal Dimensional Data	51	Controls: CXM2 Communicating Controls
16	SB072-120 Vertical Dimensional Data	52	Blower Adjustment
17	SB072-120 with WSE Vertical Dimensional Data	53	VFD Operation
18	SB168-240 Vertical Dimensional Data	56	Tensioning V-Belt Drives
19	SB168-240 with WSE Vertical Dimensional Data	57	Blower Sheave Information
20	SB300 Vertical Dimensional Data	58	Blower Performance
21	SB300 with WSE Vertical Dimensional Data	79	Operating Limits and Commissioning Conditions
22	Horizontal Installation	80	Piping System Cleaning and Flushing
26	Horizontal Field Conversion of Air Discharge	81	Unit and System Checkout
29	Vertical Installation	82	Unit Startup Procedure
30	Vertical Field Conversion of Air Discharge (072-120)	85	Unit Operating Conditions
32	Vertical Field Conversion of Control Box (072-300)	92	Startup Log Sheet
33	Vertical Field Conversion of Water Connections (072-240)	95	Functional Troubleshooting
34	Vertical Condensate Installation	97	Performance Troubleshooting
35	Piping Installation	99	Functional Troubleshooting Form
36	Water-Loop Heat Pump Applications	100	Warranty (U.S. & Canada)
37	Ground-Loop Heat Pump Application	101	Warranty (International)
38	Water Quality Requirements	104	Revision History

ClimateMaster works continually to improve its products. As a result, the design and specifications of each product at the time of order may be changed without notice and may not be as described herein. Please contact ClimateMaster's Customer Service Department at 800-299-9747 for specific information on the current design and specifications. Statements and other information contained herein are not express warranties and do not form the basis of any bargain between the parties, but are merely ClimateMaster's opinion or commendation of its products.

Model Nomenclature

1 | 2 | 3 | 4 | 5 | 6 | 7 | 8 | 9 | 10 | 11 | 12 | 13 | 14 | 15
S | **B** | **L** | **O** | **7** | **2** | **A** | **K** | **C** | **N** | **O** | **C** | **O** | **1** | **S**

PRODUCT NAME

S = R-454B Refrigerant

MODEL TYPE

B = Compact High-Capacity Series

SUPPLY/RETURN CONFIGURATION

Horizontal		
Supply	Return	
	Left	Right
Straight	L	R
Back	B	P

Vertical	
Return/Supply	Option
Front/Top	F
Back/Top	C
Back/Front	G
Front/Back	H

SIZE

072	192
096	240
120	300
168	

REVISION

A = Current

VOLTAGE

3 Phase 60 Hz	With RDS
208/230V	K
460V	L
575V	M

CONTROLS

Control	Standard	MPC
CXM2	C	N
CXM2 with Disconnect	W	R

STANDARD

S = Standard

BLOWER MOTOR

		Belt Drive	Single-Point Power	Dual-Point Power
Standard Motor	Standard RPM		1	A
	Low RPM		2	B
	High RPM		3	C
Large Motor	Standard RPM		4	D
	High RPM		5	E
VFD			6	F

EXTENDED OPTIONS

0 = Standard, None
 W = Waterside Economizer

DRAIN PAN/HEAT EXCHANGER OPTIONS

C = Standard Drain Pan, Nonplated Air Coil
 S = Stainless-Steel Drain Pan, Nonplated Air Coil
 E = Standard Drain Pan, E-Coated Air Coil
 M = Stainless-Steel Drain Pan, E-Coated Air Coil

WATER OPTIONS

	Copper	
	Left-side Water Connection	Right-side Water Connection
None	0	Z
MWV	M	V
MOD/MWV	C	N

CABINET OPTIONS

Cabinet	UltraQuiet	Rail / Frame		
		1"	2"	1"
Extended Range	No	1	J	Q
	Yes	2	L	T
Standard Range	No	3	N	U
	Yes	4	F	V

Use ClimateMaster's selection software at <https://climatemastersolutions.com/eRep/> to configure your Tranquility SB model.

Models:
SB
072-300

Attentions, Cautions, and Warnings

SAFETY

Warnings, cautions, and notices appear throughout this manual. Read these items carefully before attempting any installation, service, or troubleshooting of the equipment.

DANGER: Indicates an immediate hazardous situation, which if not avoided will result in death or serious injury. DANGER labels on unit access panels must be observed.

WARNING: Indicates a potentially hazardous situation, which if not avoided could result in death or serious injury.

CAUTION: Indicates a potentially hazardous situation or an unsafe practice, which if not avoided could result in minor or moderate injury or product or property damage.

NOTICE: Notification of installation, operation, or maintenance information, which is important, but which is not hazard-related.

WARNING



Disconnect power supply(ies) before servicing. Refer servicing to qualified service personnel. Electric shock hazard. May result in injury or death!

WARNING

To avoid the release of refrigerant into the atmosphere, the refrigerant circuit of this unit must be serviced only by technicians who meet local, state, and federal proficiency requirements.

WARNING

The installation of water-source heat pumps and all associated components, parts, and accessories which make up the installation shall be in accordance with the regulations of ALL authorities having jurisdiction and MUST conform to all applicable codes. It is the responsibility of the installing contractor to determine and comply with ALL applicable codes and regulations.

WARNING

The appliance shall be stored in a room without continuously operating ignition sources (for example: open flames, an operating gas appliance or an operating electric heater).

WARNING

If unit connected via an air duct system to one or more rooms with R-454B is installed in a room with an area less than A_{min} or has an Effective Dispersal Volume less than minimum, that room shall be without continuously operating open flames or other POTENTIAL IGNITION SOURCES. A flame-producing device may be installed in the same space if the device is provided with an effective flame arrest.

WARNING

All refrigerant discharged from this unit must be recovered WITHOUT EXCEPTION. Technicians must follow industry accepted guidelines and all local, state, and federal statutes for the recovery and disposal of refrigerants. If a compressor is removed from this unit, refrigerant circuit oil will remain in the compressor. To avoid leakage of compressor oil, refrigerant lines of the compressor must be sealed after it is removed.

WARNING

This appliance is not intended for use by persons (including children) with reduced physical, sensory, or mental capabilities, or lack of experience and knowledge, unless they have been given supervision or instruction concerning use of the appliance by a person responsible for their safety.

WARNING

An unventilated area where the appliance using FLAMMABLE REFRIGERANTS is installed shall be so constructed that should any refrigerant leak, it will not stagnate so as to create a fire or explosion hazard.

WARNING

Auxiliary devices which may be a POTENTIAL IGNITION SOURCE shall not be installed in the duct work. Examples of such POTENTIAL IGNITION SOURCES are hot surfaces with a temperature exceeding 1,292°F (700°C)

WARNING

An unventilated area where a water source heat pump is installed and surpasses a R-454B refrigerant charge of 62 oz (1.76 kg), shall be without continuously operating open flames (for example an operating gas appliance) or other POTENTIAL IGNITION SOURCES (for example, an operating electric heater, hot surfaces).

WARNING

Only auxiliary electric heaters approved by ClimateMaster shall be installed in connecting ductwork. The installation of any other auxiliary devices is beyond ClimateMaster's responsibility.

WARNING

For mechanical ventilation, the lower edge of the air extraction opening where air is exhausted from the room shall not be more than 3.94 inches (100 mm) above the floor. The location where the mechanical ventilation air extracted from the space is discharged shall be separated by a sufficient distance, but not less than 9.84 feet (3 m), from mechanical ventilation air intake openings, to prevent recirculation to the space.

WARNING

Children being supervised are NOT to play with the appliance.

WARNING

Do not pierce or burn.

WARNING

Be aware that refrigerants may not contain odor.

Attentions, Cautions, and Warnings

CAUTION

DO NOT store or install units in corrosive environments or in locations subject to temperature or humidity extremes (e.g., attics, garages, rooftops, etc.). Corrosive conditions and high temperature or humidity can significantly reduce performance, reliability, and service life. Always move and store units in an upright position. Tilting units on their sides will cause equipment damage.

CAUTION

CUT HAZARD - Failure to follow this caution may result in personal injury. Sheet metal parts may have sharp edges or burrs. Use care and wear appropriate protective clothing, safety glasses and gloves when handling parts and servicing heat pumps.

CAUTION

To avoid equipment damage, DO NOT use these units as a source of heating or cooling during the construction process. The mechanical components and filters can quickly become clogged with construction dirt and debris, which may cause system damage and void product warranty.

CAUTION

All three phase scroll compressors must have direction of rotation verified at startup. Verification is achieved by checking compressor Amp draw. Amp draw will be substantially lower compared to nameplate values. Additionally, reverse rotation results in an elevated sound level compared to correct rotation. Reverse rotation will result in compressor internal overload trip within several minutes. Verify compressor type before proceeding.

NOTICE

Servicing shall be performed only as recommended by the manufacturer.

NOTICE

REFRIGERANT SENSORS for REFRIGERANT DETECTION SYSTEMS shall only be replaced with sensors specified by the appliance manufacturer.

NOTICE

An unconditioned attic is not considered natural ventilation.

NOTICE

This unit is equipped with electrically powered safety measures. To be effective, the unit must be electrically powered at all times after installation, other than when servicing.

NOTICE

For Installation Only in Locations Not Accessible to the General Public.

NOTICE

Maximum external statics must be adhered to in order to maintain minimum CFM.

NOTICE

LEAK DETECTION SYSTEM installed. Unit must be powered except for service.

Models:
SB
072-300

General Information

INSPECTION

Upon receipt of the equipment, carefully check the shipment against the bill of lading. Make sure all units have been received. Inspect the packaging of each unit, and inspect each unit for damage. Ensure that the carrier makes proper notation of any shortages or damage on all copies of the freight bill and completes a common carrier inspection report. Concealed damage not discovered during unloading must be reported to the carrier within 15 days of receipt of shipment. If not filed within 15 days, the freight company can deny the claim without recourse.

NOTE: It is the responsibility of the purchaser to file all necessary claims with the carrier. Notify your equipment supplier of all damage within 15 days of shipment.

STORAGE

Equipment should be stored in its original packaging in a clean, dry area. Store units in an upright position at all times. You may stack vertical configurations a maximum of two units high and horizontal configurations a maximum of three units high.

UNIT PROTECTION

Cover units on the job site with either the original packaging or an equivalent protective covering. Cap the open ends of pipes stored on the job site. In areas where painting, plastering, and/or spraying has not been completed, all due precautions must be taken to avoid physical damage to the units and contamination by foreign material. Physical damage and contamination may prevent proper startup and may result in costly equipment cleanup.

Examine all pipes, fittings, and valves before installing any of the system components. Remove any dirt or debris found in or on these components.

PRE-INSTALLATION

Installation, Operation, and Maintenance instructions are provided with each unit. Horizontal equipment is designed for installation above false ceiling or in a ceiling plenum. Other unit configurations are typically installed in a mechanical room. The installation site chosen should include adequate service clearance around the unit. Before unit startup, read all manuals and become familiar with the unit and its operation. Thoroughly check the system before operation.

PREPARE UNITS FOR INSTALLATION AS FOLLOWS:

1. Compare the electrical data on the unit nameplate with ordering and shipping information to verify that the correct unit has been shipped.
2. Keep the cabinet covered with the original packaging until installation is complete and all plastering, painting, etc. is finished.
3. Verify refrigerant tubing is free of kinks or dents and that it does not touch other unit components.
4. Inspect all electrical connections. Connections must be clean and tight at the terminals.
5. Remove any blower support packaging (water-to-air units only).
6. Some airflow patterns are field convertible (horizontal units only). Locate the airflow conversion section of this IOM.
7. Locate and verify any hot water generator (HWG), hanger, or other accessory kit located in the compressor section or blower section.

CHECKS TO THE AREA

Prior to beginning work on systems containing FLAMMABLE REFRIGERANTS, safety checks are necessary to ensure that the risk of ignition is minimized. For repair to the REFRIGERATING SYSTEM, these steps shall be completed prior to conducting work on the system.

General Information

Work Procedure

Work shall be undertaken under a controlled procedure so as to minimise the risk of a flammable gas or vapor being present while the work is being performed.

General Work Area

All maintenance staff and others working in the local area shall be instructed on the nature of work being carried out. Work in confined spaces shall be avoided.

Checking for presence of refrigerant

The area shall be checked with an appropriate refrigerant detector prior to and during work, to ensure the technician is aware of potentially toxic or flammable atmospheres. Ensure that the leak detection equipment being used is suitable for use with all applicable refrigerants, i.e. non-sparking, adequately sealed or intrinsically safe.

Presence of fire Extinguisher

If any hot work is to be conducted on the refrigeration equipment or any associated parts, appropriate fire extinguishing equipment shall be available to hand. Have a dry powder or CO₂ fire extinguisher adjacent to the charging area.

No ignition sources

No person carrying out work in relation to a REFRIGERATION SYSTEM which involves exposing any pipe work shall use any sources of ignition in such a manner that it may lead to the risk of fire or explosion. All possible ignition sources, including cigarette smoking, should be kept sufficiently far away from the site of installation, repairing, removing and disposal, during which refrigerant can possibly be released to the surrounding space. Prior to work taking place, the area around the equipment is to be surveyed to make sure that there are no flammable hazards or ignition risks. "No Smoking" signs shall be displayed.

Ventilated area

Ensure that the area is in the open or that it is adequately ventilated before breaking into the system or conducting any hot work. A degree of ventilation shall continue during the period that the work is carried out. The ventilation should safely disperse any released refrigerant and preferably expel it externally into the atmosphere.

Checks to the Refrigeration Equipment

The following checks shall be applied to installations using FLAMMABLE REFRIGERANTS:

- The actual REFRIGERANT CHARGE is in accordance with the room size within which the refrigerant containing parts are installed;
- The ventilation machinery and outlets are operating adequately and are not obstructed;
- If an indirect refrigerating circuit is being used, the secondary circuit shall be checked for the presence of refrigerant;
- Marking to the equipment continues to be visible and legible. Markings and signs that are illegible shall be corrected;
- Refrigerant piping or components are installed in a position where they are unlikely to be exposed to any substance which may corrode refrigerant containing components, unless the components are constructed of materials which are inherently resistant to being corroded or are suitably protected against being so corroded.

Checks to Electrical Devices

Repair and maintenance to electrical components shall include initial safety checks and component inspection procedures. If a fault exists that could compromise safety, then no electrical supply shall be connected to the circuit until it is satisfactorily dealt with. If the fault cannot be corrected immediately but it is necessary to continue operation, an adequate temporary solution shall be used. This shall be reported to the owner of the equipment so all parties are advised.

Initial safety checks shall include:

- Capacitors are discharged: this shall be done in a safe manner to avoid possibility of sparking;
- That no live electrical components and wiring are exposed while charging, recovering, or purging the system;
- That there is continuity of earth bonding.

Models:
SB
072-300

General Information

REPAIR TO INTRINSICALLY SAFE COMPONENTS

Intrinsically safe components must be replaced.

CABLING

Check that cabling will not be subject to wear, corrosion, excessive pressure, vibration, sharp edges or any other adverse environmental effects. The check shall also take into account the effects of aging or continual vibration from sources such as compressors or fans.

REQUIRED AREA FOR INSTALLATION

The minimum room area of the space (A_{min}) or a minimum room area of conditioned space (TA_{min}) shall be corrected for unit's location altitude by multiplying A_{min} or TA_{min} by the applicable altitude adjustment factor (AF) for building ground-level altitude (H_{alt}) in feet or meters, as shown in Table 1.

NOTE:

- You can use Imperial or Metric measurements to calculate A_{min} or TA_{min} .
- The maximum allowable altitude of installation for this product is 6,561 ft (2,000 m).

Table 1:Altitude Adjustment

H_{alt} ft (m)	AF
0 (0)	1.00
656 (200)	1.00
1,312 (400)	1.00
1,968 (600)	1.00
2,624 (800)	1.02
3,280 (1,000)	1.05
3,937 (1,200)	1.07
4,593 (1,400)	1.10
5,249 (1,600)	1.12
5,905 (1,800)	1.15
6,561 (2,000)	1.18

Minimum Installation Area

MINIMUM INSTALLATION AREA

Minimum area where a blower-equipped unit must be installed, and mechanical/natural ventilation is not required

Model	Charge (oz)	Configuration	Minimum Installation Area ft ² (m ²) [A _{min}]			
			Floor	Window	Wall	Ceiling
SB072	54	Vertical	186	70	46	40
		Horizontal	186	70	46	40
SB096	62	Vertical	213	80	53	46
		Horizontal	213	80	53	46
SB120	66	Vertical	227	85	57	49
		Horizontal	213	80	53	46
SB168	94	Vertical	323	121	81	69
SB192	103	Vertical	354	133	89	76
SB240	134	Vertical	461	173	115	99
SB300	184	Vertical	633	237	158	136

A _{min} =	Minimum area where unit is installed where unit has incorporated airflow
h _{inst} (floor) =	0.0 ft (0.0 m)
h _{inst} (window) =	3.3 ft (1.0 m)
h _{inst} (wall) =	5.9 ft (1.8 m)
h _{inst} (ceiling) =	7.2 ft (2.2 m)

Minimum area and CFM requirements for the conditioned space

Model	Charge (oz)	Minimum CFM [Q _{min}]	
		TA _{min} (ft ²)	Q _{min} (ft ³ /min)
SB072	54	2.77	91
SB096	62	3.18	105
SB120	66	3.38	112
SB168	94	4.82	159
SB192	103	5.28	174
SB240	134	6.87	227
SB300	184	9.43	311

TA _{min} =	Minimum conditioned area for venting leaked refrigerant
Q _{min} =	Minimum ventilation flow rate for conditioned space if space is less than TA _{min}

Minimum area of opening for natural ventilation

Model	Charge (oz)	A _{nv} (in ²)
SB072	54	98.70
SB096	62	105.76
SB120	66	109.12
SB168	94	130.22
SB192	103	136.31
SB240	134	155.48
SB300	184	182.19

A _{nv} =	Minimum natural ventilation area opening
-------------------	------------------------------------------

When the openings for connected rooms or natural ventilation are required, the following conditions shall be applied:

- The area of any openings above 11.8 inches (300 mm) from the floor shall not be considered in determining compliance with Anv_{min}.
- At least 50% of the required opening area Anv_{min} shall be below 7.8 inches (200 mm) from the floor.
- The bottom of the lowest openings shall not be higher than the point of release when the unit is installed and not more than 3.9 inches (100 mm) from the floor.
- Openings are permanent openings which cannot be closed.
- For openings extending to the floor, the height shall not be less than 0.78 inch (20 mm) above the surface of the floor covering.
- A second higher opening shall be provided. The total size of the second opening shall not be less than 50% of minimum opening area for Anv_{min} and shall be at least 3.3 ft (1.5 m) above the floor.

Refrigerant System Servicing

REFRIGERANT SYSTEM

To maintain sealed circuit integrity, do not install service gauges unless unit operation appears abnormal. Reference the operating charts for pressures and temperatures. Verify that air and water flow rates are at proper levels before servicing the refrigerant circuit.

Removal and Evacuation

When breaking into the refrigerant circuit to make repairs - or for any other purpose - conventional procedures shall be used. However, for flammable refrigerants it is important that best practice be followed, since flammability is a consideration. The following procedure shall be adhered to:

- Safely remove refrigerant following local and national regulations
- Evacuate
- Purge the circuit with Inert gas
- Evacuate
- Continuously flush or purge with Inert gas when using flame to open circuit
- Open the circuit.

The refrigerant charge shall be recovered into the correct recovery cylinders. For appliances containing flammable refrigerants, the system shall be purged with oxygen-free nitrogen to render the appliance safe. This process might need to be repeated several times. Compressed air or oxygen shall not be used for purging refrigerant systems.

For appliances containing flammable refrigerants, refrigerant purging shall be achieved by breaking the vacuum in the system with oxygen-free nitrogen and continuing to fill until the working pressure is achieved, then venting to atmosphere, and finally pulling down to a vacuum (optional for FLAMMABLE REFRIGERANT). This process shall be repeated until no refrigerant remains in the system (optional for FLAMMABLE REFRIGERANT). When the final oxygen-free nitrogen charge is used, the system shall be vented down to atmospheric pressure to enable work to take place.

The outlet for the vacuum pump shall not be close to any potential ignition sources, and ventilation shall be available.

Charging Procedures

In addition to conventional charging procedures, the following requirements shall be followed:

- Ensure that contamination of different refrigerants does not occur when using charging equipment.
- Hoses or lines shall be as short as possible to minimize the amount of refrigerant contained in them.
- Cylinders shall be kept in an appropriate position according to the instructions.
- Ensure that the REFRIGERATION SYSTEM is earthed prior to charging the system with refrigerant.
- Label the system when charging is complete (if not already).
- Extreme care shall be taken not to overfill the REFRIGERATION SYSTEM.

Prior to recharging the system, it shall be pressure-tested with the appropriate purging gas. The system shall be leak-tested on completion of charging but prior to commissioning. A follow up leak test shall be carried out prior to leaving the site.

Leak Detection

Under no circumstances shall potential sources of ignition be used in the searching for or detection of refrigerant leaks. A halide torch (or any other detector using a naked flame) shall not be used.

The following leak detection methods are deemed acceptable for all refrigerant systems.

Electronic leak detectors may be used to detect refrigerant leaks but, in the case of FLAMMABLE REFRIGERANTS, the sensitivity may not be adequate, or may need re-calibration. (Detection equipment shall be calibrated in a refrigerant-free area.) Ensure that the detector is not a potential source of ignition and is suitable for the refrigerant used. Leak detection equipment shall be set at a percentage of the lower flammability limit of the refrigerant and shall be calibrated to the refrigerant employed, and the appropriate percentage of gas (25% maximum) is confirmed.

Refrigerant System Servicing

Leak detection fluids are also suitable for use with most refrigerants but the use of detergents containing chlorine shall be avoided as the chlorine may react with the refrigerant and corrode the copper pipe-work.

NOTE:

Examples of leak detection fluids are:

- Bubble method
- Fluorescent method agents

If a leak is suspected, all naked flames shall be removed/extinguished.

If a refrigerant leak that requires brazing is identified, all of the refrigerant shall be recovered from the system, or isolated (by means of shut off valves) in a part of the system remote from the leak. Removal of refrigerant shall be according to Removal and Evacuation section.

DECOMMISSIONING

Before carrying out this procedure, it is essential that the technician is completely familiar with the equipment and all its detail. It is recommended good practice that all refrigerants are recovered safely. Prior to the task being carried out, an oil and refrigerant sample shall be taken in case analysis is required prior to re-use of recovered refrigerant. It is essential that electrical power is available before the task is commenced.

1. Become familiar with the equipment and its operation.
2. Isolate system electrically.
3. Before attempting the procedure, ensure that:
 - Mechanical handling equipment is available, if required, for handling refrigerant cylinders.
 - All personal protective equipment is available and being used correctly.
 - The recovery process is supervised at all times by a competent person.
 - Recovery equipment and cylinders conform to the appropriate standards.

4. Pump down refrigerant system, if possible.
5. If a vacuum is not possible, make a manifold so that refrigerant can be removed from various parts of the system.
6. Make sure that cylinder is situated on the scales before recovery takes place.
7. Start the recovery machine and operate in accordance with instructions.
8. Do not overfill cylinders (no more than 80 % volume liquid charge).
9. Do not exceed the maximum working pressure of the cylinder, even temporarily.
10. When the cylinders have been filled correctly and the process completed, make sure that the cylinders and the equipment are removed from site promptly and all isolation valves on the equipment are closed off.
11. Recovered refrigerant shall not be charged into another REFRIGERATING SYSTEM unless it has been cleaned and checked.

Labeling - Upon decommissioning, equipment shall be labeled stating that it has been decommissioned and emptied of refrigerant. The label shall be dated and signed.

Models:
SB
072-300

Refrigerant System Servicing

RECOVERY

When removing refrigerant from a system, either for servicing or decommissioning, it is recommended good practice that all refrigerants are removed safely.

When transferring refrigerant into cylinders, ensure that only appropriate refrigerant recovery cylinders are employed. Ensure that the correct number of cylinders for holding the total system charge is available. All cylinders to be used are designated for the recovered refrigerant and labeled for that refrigerant (i.e. special cylinders for the recovery of refrigerant). Cylinders shall be complete with pressure-relief valve and associated shut-off valves in good working order. Empty recovery cylinders are evacuated and, if possible, cooled before recovery occurs.

The recovery equipment shall be in good working order with a set of instructions concerning the equipment that is at hand and shall be suitable for the recovery of the flammable refrigerant. If in doubt, the manufacturer should be consulted.

In addition, a set of calibrated weighing scales shall be available and in good working order. Hoses shall be complete with leak-free disconnect couplings and in good condition.

The recovered refrigerant shall be processed according to local legislation in the correct recovery cylinder, and the relevant waste transfer note arranged. Do not mix refrigerants in recovery units and especially not in cylinders.

If compressors or compressor oils are to be removed, ensure that they have been evacuated to an acceptable level to make certain that flammable refrigerant does not remain within the lubricant. The compressor body shall not be heated by an open flame or other ignition sources to accelerate this process. When oil is drained from a system, it shall be carried out safely.

Physical Data

Models:
SB
072-300

SB Physical Data

Configuration	Horizontal			Vertical						
Unit Size	072	096	120	072	096	120	168	192	240	300
Compressor Type	Scroll			Scroll						
Number of Circuits (Compressors)	2			2						
Refrigerant Leak Detection System	R	R	R	R	R	R	R	R	R	R
Number of Sensors	2	2	2	2	2	2	2	2	2	2
Factory Charge R-454B (oz) [kg] per Circuit	54 [1.5]	62 [1.8]	66 [1.9]	54 [1.5]	62 [1.8]	66 [1.9]	94 [2.7]	103 [2.9]	134 [3.8]	184 [5.2]
Blower Motor										
Standard Motor (hp) [kW]	1 [0.75]	2 [1.49]	3 [2.23]	1 [0.75]	2 [1.49]	3 [2.23]		5 [3.73]		7.5 [5.60]
*Large Motor (hp) [kW]	2 [1.49]	3 [2.23]	5 [3.73]	2 [1.49]	3 [2.23]	5 [3.73]		7.5 [5.60]		10 [7.46]
Water Connections										
FPT (in) [mm]	1-1/4" [31.8]		1-1/2" [38.1]	1-1/4" [31.8]		1-1/2" [38.1]	2" [50.8]		2-1/2" [63.5]	
Coax Data										
Number of Coaxes per Circuit	1			1			2		3	
Volume per Coax (gallon) [liter]	1.62 [6.13]	2.40 [9.08]	2.40 [9.08]	1.62 [6.13]	2.40 [9.08]	2.40 [9.08]	3.62 [13.70]	4.83 [18.28]	4.90 [18.55]	7.39 [27.98]
Condensate Connection Size										
FPT (in) [mm]	3/4" [19.1]			1" [25.4]						
Miscellaneous Data										
Filter Standard - 1" [2.54cm] Throwaway (qty) (in) [cm]	(QTY.3) 16 x 20 [40.6 x 50.8]			(QTY.4) 20 x 20 [50.8 x 50.8]			(QTY.4) 20 x 25 [50.80 x 63.5]			
	(QTY.1) 20 x 20 [50.8 x 50.8]						(QTY.2) 20 x 30 [50.80 x 76.2]			
Weight - Operating (lbs) [kg]	586 [265.8]	644 [292.1]	698 [316.6]	586 [265.8]	644 [292.1]	698 [316.6]	1069 [484.9]	1164 [528.0]	1184 [537.1]	1297 [588.3]
Weight - Packaged (lbs) [kg]	626 [283.9]	684 [310.3]	738 [334.8]	626 [283.9]	684 [310.3]	738 [334.8]	1149 [521.2]	1244 [564.3]	1264 [573.3]	1377 [624.6]

O = Optional, R = Required

SB with WSE Physical Data

Unit Size	072	096	120	168	192	240	300
Vertical							
Weight - Operating (lbs.) [kg]	762 [345.5]	837 [379.7]	907 [411.6]	1529 [693.4]	1665 [755]	1693 [768]	1855 [841.3]
Weight - Packaged (lbs.) [kg]	814 [369.1]	889 [403.3]	962 [436.4]	1643 [745.3]	1779 [806.9]	1808 [819.9]	1974 [895.4]
Air Coil Volume (gal) [L]	4.3	4.8		9.7		19	
Horizontal							
Weight - Operating (lbs.) [kg]	838 [380.1]	921 [417.7]	998 [452.7]				
Weight - Packaged (lbs.) [kg]	900 [408.2]	978 [443.7]	1008 [457.2]				
Air Coil Volume (gal) [L]	4	4.4					

Models:
SB
072-300

SB072-120 Horizontal Dimensional Data

Unit Size	Overall Cabinet			Discharge Connections Duct Flange				Water Connections			Electrical Knockouts						Return Air Connections Using Return Air Opening								
	A	B	C	D	E	F	G	K	L	M	P				Q		S		T	U	V				
	Width	Depth	Height	Flange Offset	Supply Depth	Supply Width	Supply Height		Water Outlet	Water Inlet	1	2	1	2	3	4	1	2	Return Depth		Return Height	Unit Top Height			
											1-1/8" (2.9 cm)	7/8" (2.2 cm)	1-1/8" (2.9 cm)				7/8" (2.2 cm)		072	096-120					
072-120	inch	36.3	84.9	21.6	13.9	17.1	13.5	7.4	15.0	18.0	3.5	3.0	2.7	19.4	14.3	7.3	2.1	16.8	4.8	55.0	65.0	18.0	1.0	28.9	18.9
	cm	92.2	215.6	54.9	35.2	43.4	34.3	19.8	38.1	45.7	8.9	7.6	6.8	49.2	36.3	18.6	5.4	42.7	12.2	139.7	165.1	45.7	2.5	73.4	48.0

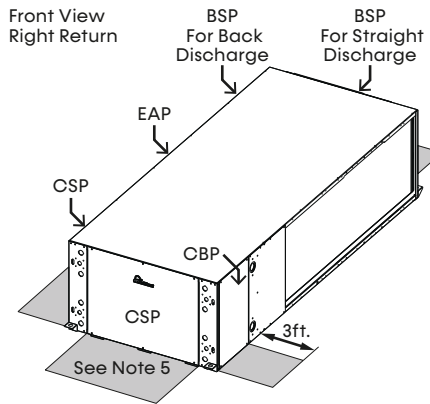
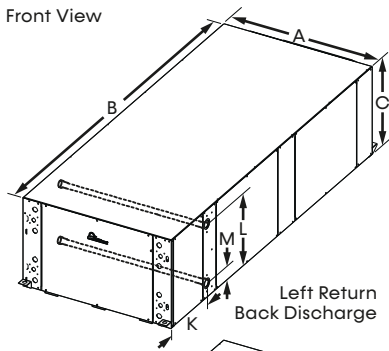

Notes:

- All dimensions in table are inches (cm).
- Water inlet and water outlet connections are configurable on either side (left or right) of the unit. Qty (2x) MPT Plugs are shipped loose in a plastic bag tied to the water leg in front of the unit. Installer must plug water inlet/outlet side not being connected to.
 - Condensate drain is 3/4-inch FPT and is located on cabinet end opposite the compressor.
 - Electrical access is configurable on either side (left or right) of the front.
 - If the control box is configured on one side, it can be field converted to the opposite side. Conversion should only be attempted by a qualified service technician.
 - Units require 3 feet (90.1 cm) of clearance for water connections, CSP, CBP, EAP, and BSP service access. Service access is required at all removable panels locations and installer should take care to comply with all building codes and allow adequate clearance for future field service.
 - Overall cabinet width dimensions do not include filter rail and duct flange.
 - Units are shipped with air-filter rails that are not suitable for supporting return air ductwork. An air-filter frame with duct-mounting collar is available to order as an accessory.

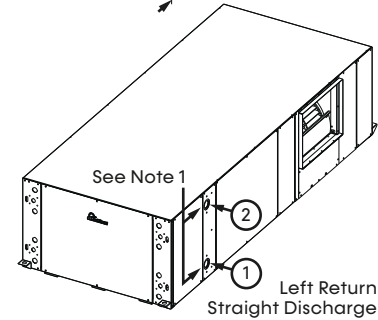

Legend:

- BSP = Blower Service Panel
- CSP = Compressor Service Panel
- CBP = Control Box Panel
- EAP = Expansion Valve Access Panel

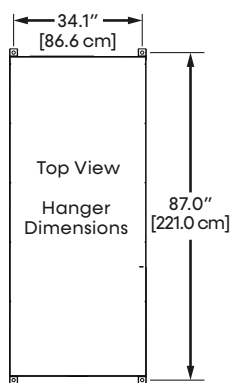
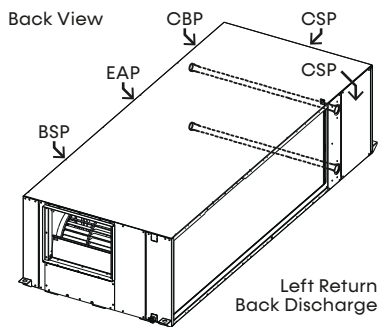

Legend	SB072-096	SB120
① Water Inlet ¹	1-1/4" FPT	1-1/2" FPT
② Water Outlet ¹	1-1/4" FPT	1-1/2" FPT
③ Condensate Drain ²	1" FPT	
④ High Voltage Access ³	1-3/8" (3.49 cm)	
⑤ Low Voltage Access ³	7/8" (2.2 cm)	

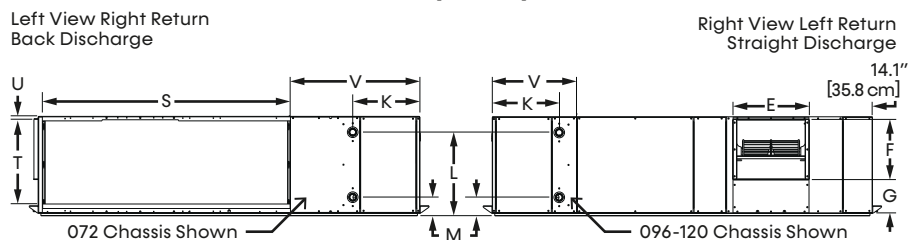
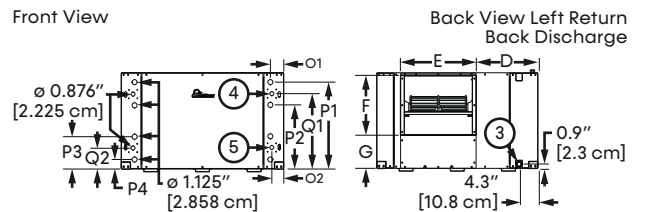
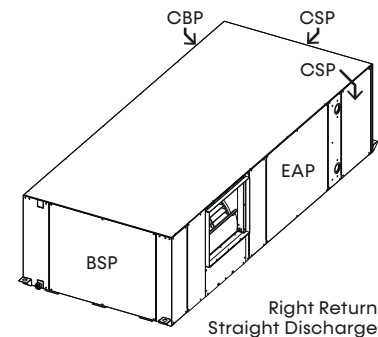

SB072-120 with WSE Horizontal Dimensional Data

Models:
SB
072-300

Unit Size	Overall Cabinet			Discharge Connections Duct Flange				Water Connections				Electrical Knockouts				Return Air Connections Using Return Air Opening												
	A	B	C	D	E	F	G	K	L	M	O		P				Q		S		T	U	V					
	Width	Depth	Height	Flange Offset	Supply Width	Supply Height	Supply Height	15.0	18.0	3.5	3.0	2.7	1	2	1	2	1	2	3	4	1	2	Return Depth		18.5	1.0	28.9	22.8
	inch	cm	inch	cm	inch	cm	inch						cm	inch	cm	inch	cm	inch	cm	inch	cm	inch	cm	inch				
072-120	46.3	84.9	21.6	23.9	17.1	13.5	7.4	15.0	18.0	3.5	3.0	2.7	1.94	14.3	7.2	2.1	16.8	4.7	55.1	61.0	18.5	1.0	28.9	22.8				
	117.6	215.6	54.8	60.6	43.4	34.3	18.8	38.1	45.7	8.9	7.6	6.8	49.2	36.3	18.3	5.4	42.7	11.9	140.0	154.9	47.0	2.5	73.4	57.9				

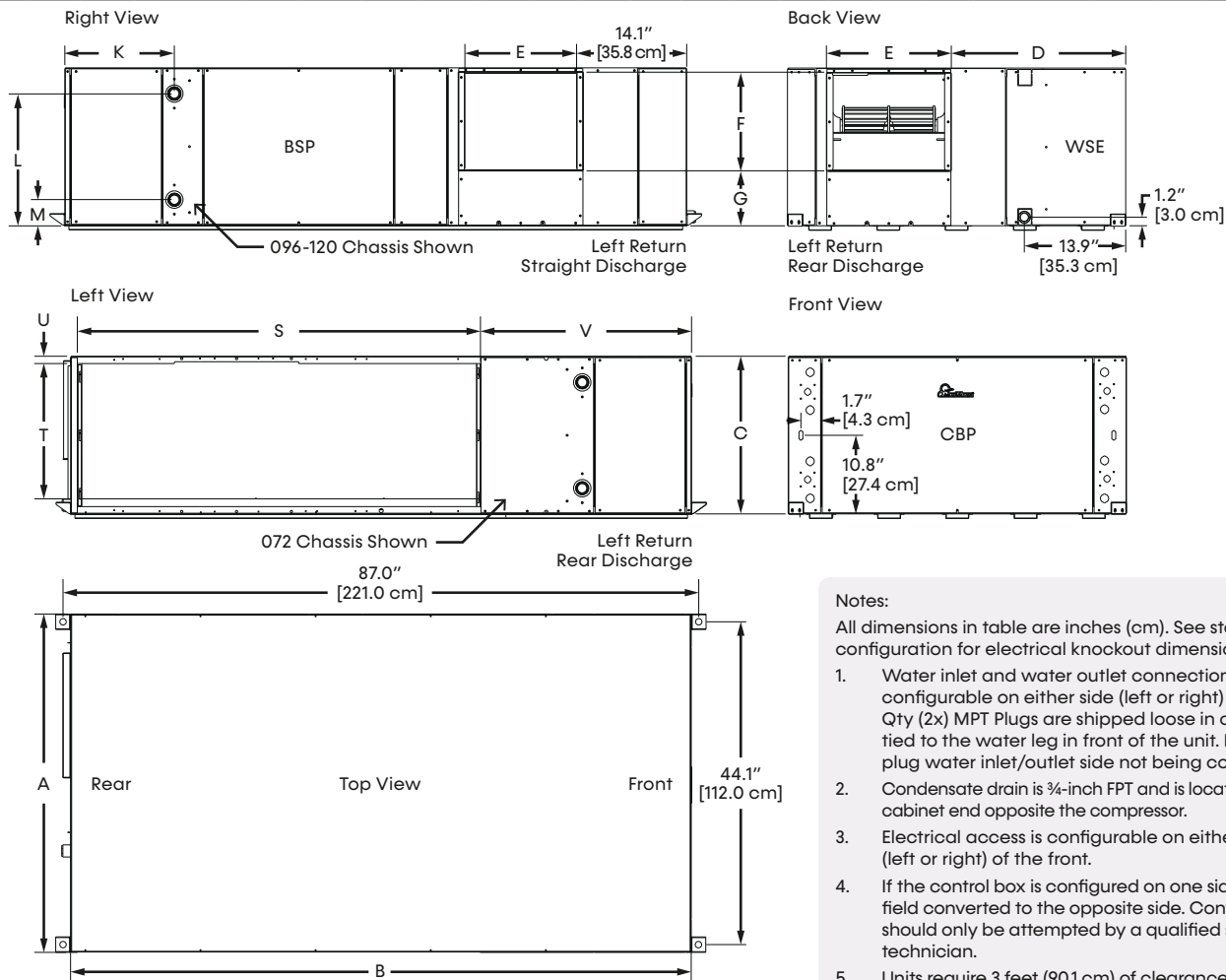

Legend:
 BSP = Blower Service Panel
 CSP = Compressor Service Panel
 CBP = Control Box Panel
 EAP = Expansion Valve Access Panel
 WSE = Waterside Economizer

- Notes:**
 All dimensions in table are inches (cm). See standard configuration for electrical knockout dimensions.
- Water inlet and water outlet connections are configurable on either side (left or right) of the unit. Qty (2x) MPT Plugs are shipped loose in a plastic bag tied to the water leg in front of the unit. Installer must plug water inlet/outlet side not being connected to.
 - Condensate drain is 3/4-inch FPT and is located on cabinet end opposite the compressor.
 - Electrical access is configurable on either side (left or right) of the front.
 - If the control box is configured on one side, it can be field converted to the opposite side. Conversion should only be attempted by a qualified service technician.
 - Units require 3 feet (90.1 cm) of clearance for water connections, CSP, CBP, EAP, and BSP service access. Service access is required at all removable panels locations and installer should take care to comply with all building codes and allow adequate clearance for future field service.
 - Overall cabinet width dimensions do not include filter rail and duct flange.
 - Units are shipped with air-filter rails that are not suitable for supporting return air ductwork. An air-filter frame with duct-mounting collar is available to order as an accessory.

Models:
SB
072-300

SB072-120 Vertical Dimensional Data

Unit Size	Overall Cabinet			Discharge Connections Duct Flange			Water Connections				Electrical Knockouts			Return Air Connections Using Return Air Opening						
	A	B	C	D	E	F	K	L	M	N	O			P	Q	S	T	U	V	
	Width	Depth	Height	Supply Width	Supply Height	Side Offset	1	2	3	Connection Height	1	2	3	7/8" (2.2 cm)	Return Width	Return Height				
072	inch	41.0	29.0	69.8	17.5	14.8	11.9	22.0	7.2	14.6	22.3	3.0	11.0						19.0	15.0
	cm	104.1	73.3	177.3	44.5	37.6	30.2	55.9	18.3	37.1	56.6	7.6	27.9	48.3	38.1	2.3	92.2	74.7	72.6	11.4
096-120	inch	41.0	29.0	69.8	17.5	14.8	11.9	22.0	7.2	14.6	22.3	3.0	11.0	19.0	15.0	0.9	36.0	35.1	28.6	2.6
	cm	104.1	73.3	177.3	44.5	37.6	30.2	55.9	18.3	37.1	56.6	7.6	27.9	48.3	38.1	2.3	91.4	89.2	72.6	6.6

Notes:

All dimensions in table are inches (cm)

1. Water inlet and water outlet connections are factory shipped on the left side. Union allows field conversion to right side.
2. Condensate drain is available on either side (left or right) of unit. Drain hose and drain connection will be tied inside the unit. Installer will untie the drain hose, form trap, and connect to the condensate drain hole of installer's choice.
3. Electrical access is available on either side (left or right) of unit and is also available in the front on the left or right side of the unit.
4. Overall cabinet dimensions do not include duct flange or filter rails.
5. Units require 3 feet (90.1 cm) of clearance for water connections, CSP, CBP, MSP, and BSP service access. Service access is required at all removable panels locations and installer should take care to comply with all building codes and allow adequate clearance for future field service.
6. Filter removal is from right or left side of filter frame, allow 3 feet (61 cm) of access for servicing.

Front View Top Discharge

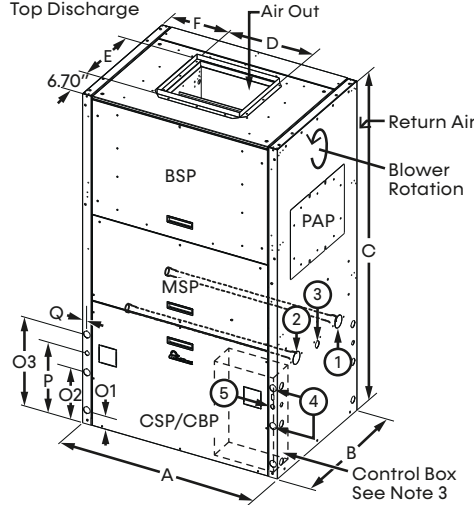

Rear View Top Discharge

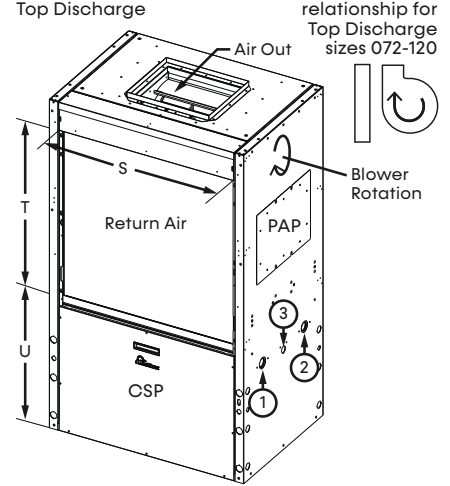

Blower to Air Coil relationship for Top Discharge sizes 072-120

Front View Straight Discharge

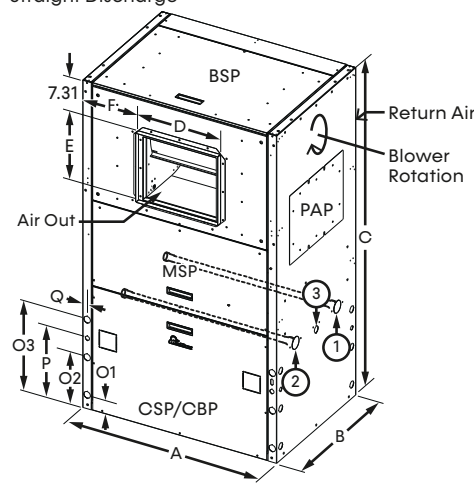

Rear View Straight Discharge

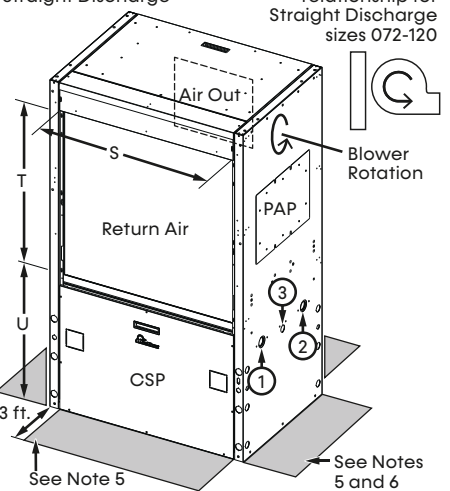

Blower to Air Coil relationship for Straight Discharge sizes 072-120

Right Side View Straight Discharge

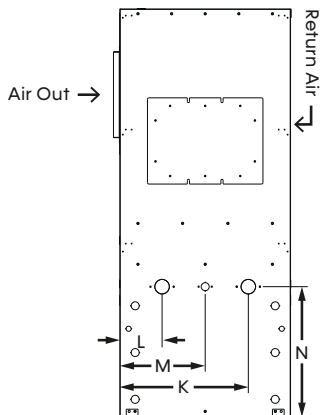

Notes	SB072-096	SB120
① Water Inlet ¹	1-1/4" FPT	1-1/2" FPT
② Water Outlet ¹	1-1/4" FPT	1-1/2" FPT
③ Condensate Drain ²	1" FPT	
④ High Voltage Access ³	1-3/8" (3.49 cm)	
⑤ Low Voltage Access ³	7/8" (2.2 cm)	

Legend

- BSP = Blower Service Panel
- CBP = Control Box Panel
- CSP = Compressor Service Panel
- MSP = Motor Service Panel
- PAP = Pulley Access Panel

SB072-120 with WSE Vertical Dimensional Data

Unit Size		Overall Cabinet			Discharge Connections Duct Flange			Water Connections				Electrical Knockouts			Return Air Connections Using Return Air Opening					
		A	B	C	D	E	F	K	L	M	N	O	P	Q	S	T	U	V		
		Width	Depth	Height	Supply Width	Supply Height	Side Offset	1	2	3	Connection Height	1	2	3	Return Width	Return Height		Return Side Offset		
072	inch	41.3	39.2	69.8	17.5	14.7	11.9	22.0	7.2	14.6	22.3	3.0	11.0	19.0	15.1	0.9	34.0	31.6	28.6	3.6
	cm	104.9	99.6	177.3	44.5	37.3	30.2	55.9	18.3	37.1	56.6	7.6	27.9	48.3	38.4	2.3	86.4	80.3	72.7	9.1
096-120	inch	41.3	39.2	69.8	17.5	14.7	11.9	22.3	6.9	14.6	22.3	3.0	11.0	19.0	15.1	0.9	36.0	34.1	28.6	3.0
	cm	104.9	99.6	177.3	44.5	37.3	30.2	56.6	17.5	37.1	56.6	7.6	27.9	48.3	38.4	2.3	91.4	86.6	72.7	7.5

Top View
Rear Return Front Discharge

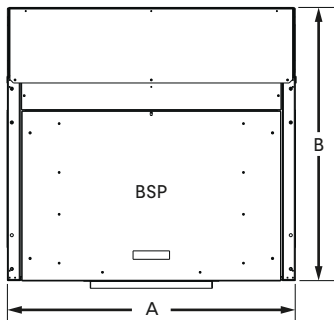

Top View
Rear Return Top Discharge

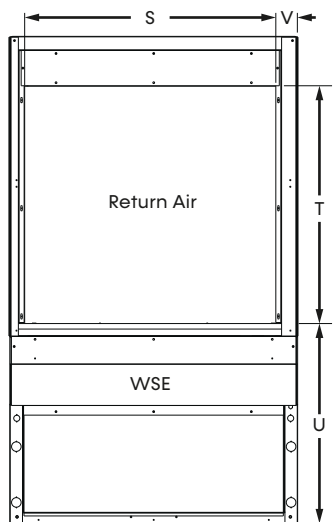
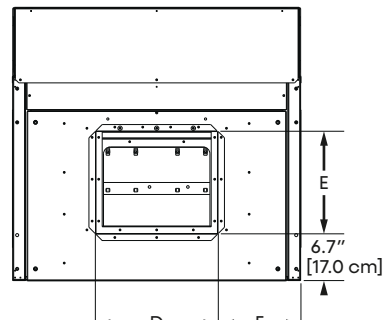

Back View
Rear Return Front Discharge

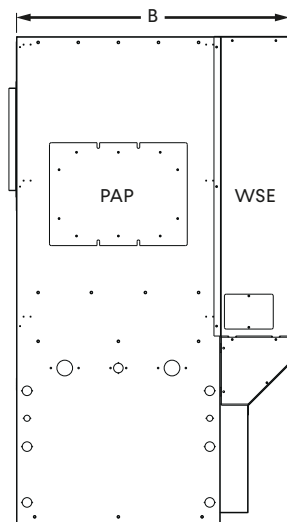

Right Side View

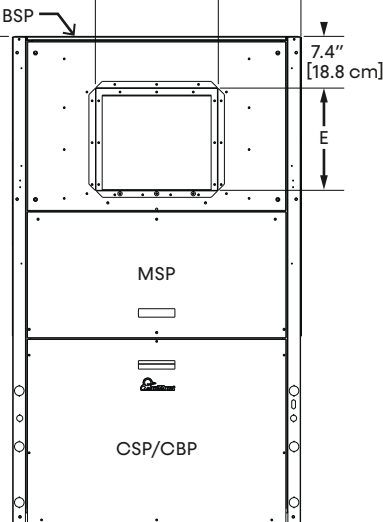

Front View
Rear Return Front Discharge

Notes:

All dimensions in table are inches (cm). See standard configuration for water connection and electrical knockout dimensions.

1. While clear access to all removable panels may not be required, installer should take care to comply with all building codes and allow adequate clearance for future field service.
2. Units require 3 feet (91 cm) of clearance for water connections, WSE coil air bleed, CBP, CSP, BSP, PAP, and MSP.
3. Condensate drain is internally trapped, externally vented.
4. For top discharge units, BSP is on front. For front discharge units, BSP is on top. Allow 3 feet above unit for service.

- BSP = Blower Service Panel
- CSP = Compressor Service Panel
- CBP = Control Box Panel
- MSP = Motor Service Panel
- PAP = Pulley Access Panel
- WSE = Waterside Economizer

Models:
SB
072-300

SB168-240 Vertical Dimensional Data

Unit Size	Overall Cabinet			Discharge Connections Duct Flange				Water Connections				Electrical Knockouts			Return Air Connections Using Return Air Opening						
	A	B	C	D	E	F	G	K	L	M	N	O			P	Q	S	T	U	V	
	Width	Depth	Height	Supply Width	Supply Height	Side Offset	Center Offset	1	2	3	Connection Height	1	2	3	7/8" (2.2 cm)	0.9	77.2	35.0	31.0	2.6	
								Water In	Water Out	Condensate		1-3/8" (3.5cm)									
168-240	inch	82.3	29.2	69.8	17.5	14.7	17.9	11.5	26.2	3.1	14.6	25.8	3.0	11.0	19.0	13.0	0.9	77.2	35.0	31.0	2.6
	cm	209.0	74.2	177.3	44.5	37.3	45.5	29.2	66.5	7.9	37.1	65.5	7.6	27.9	48.3	33.0	2.3	196.1	88.9	78.7	6.6

Front View Top Discharge

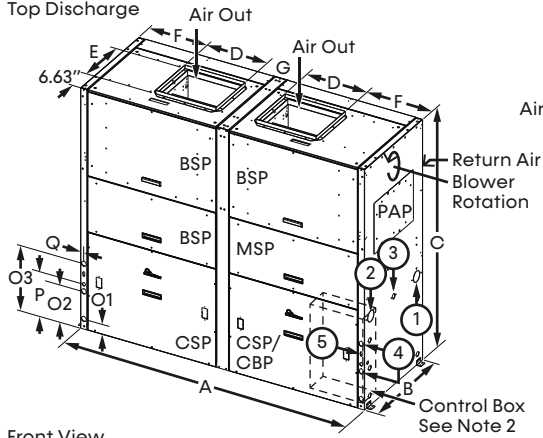

Front Return Rear Discharge (FR/RD)

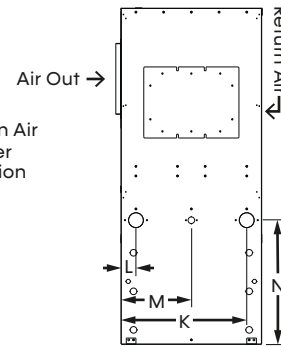

Rear View Top Discharge

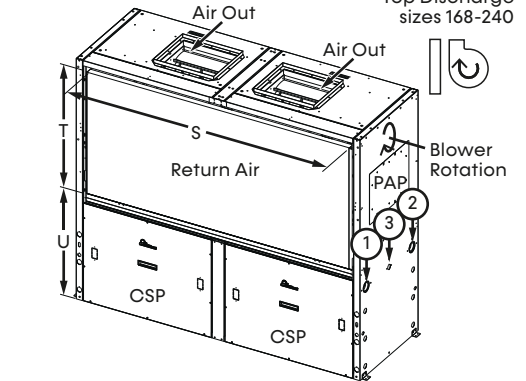

Front View Straight Discharge

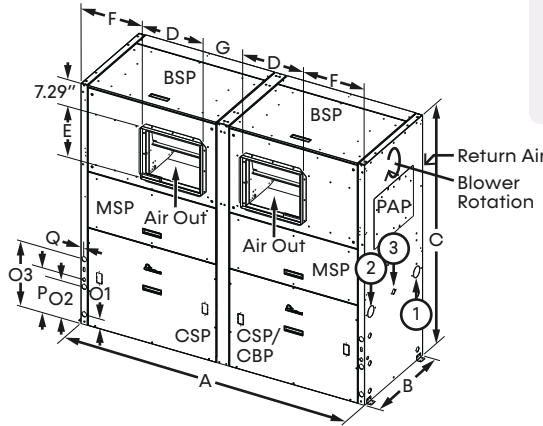

Rear View Straight Discharge

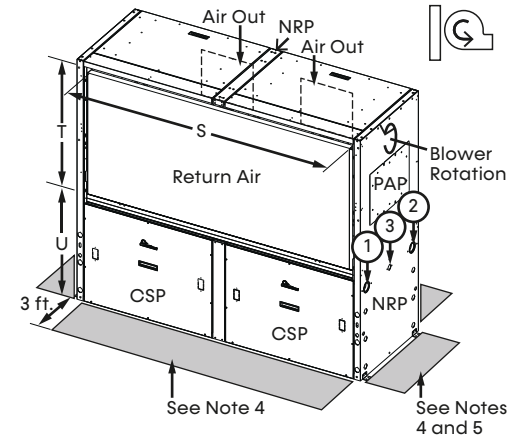

Legend
 BSP = Blower Service Panel
 CBP = Control Box Panel
 CSP = Compressor Service Panel
 MSP = Motor Service Panel
 PAP = Pulley Access Panel

Notes

- All dimensions in table are inches (cm)
- 1. Condensate drain is available on either side (left or right) of unit. Drain hose and drain connection will be tied inside the unit. Installer will untie the drain hose, form trap, and connect to the condensate drain hole of installer's choice.
- 2. Electrical access is available on either side (left or right) of unit and is also available in the front on the left or right side of the unit.
- 3. Overall cabinet height and depth dimensions do not include duct flange or filter rails.
- 4. Units require 3 feet (91 cm) of clearance for water connections, CBP, CSP, MSP, and BSP service access. Service access is required at all removable panels locations and installer should take care to comply with all building codes and allow adequate clearance for future field service.
- 5. Filter removal is from right or left side of filter frame, allow 3 feet (91 cm) of access for servicing.

Legend	SB168-240
① Water Inlet	2" FPT
② Water Outlet	2" FPT
③ Condensate Drain ¹	1" FPT
④ High Voltage Access ²	1-3/8" (3.49 cm)
⑤ Low Voltage Access ²	7/8" (2.2 cm)

SB168-240 with WSE Vertical Dimensional Data

Models:
SB
072-300

Unit Size		Overall Cabinet			Discharge Connections Duct Flange				Water Connections				Electrical Knockouts			Return Air Connections Using Return Air Opening					
		A	B	C	D	E	F	G	K	L	M	N	O	P	Q	S	T	U	V		
		Width	Depth	Height	Supply Width	Supply Height	Side Offset	Center Offset	1 Water In	2 Water Out	3 Condensate	Connection Height	1	2	3	Return Width	Return Height		Return Side Offset		
168-240	inch	82.3	42.0	69.8	17.5	14.7	17.9	11.5	26.1	3.1	14.6	25.8	3.0	11.0	19.0	15.1	0.9	76.0	34.0	30.7	3.6
	cm	209.0	106.7	177.3	44.5	37.3	45.5	29.3	66.3	7.9	37.1	65.5	7.6	27.9	48.3	38.4	2.3	193.0	86.4	78.0	9.1

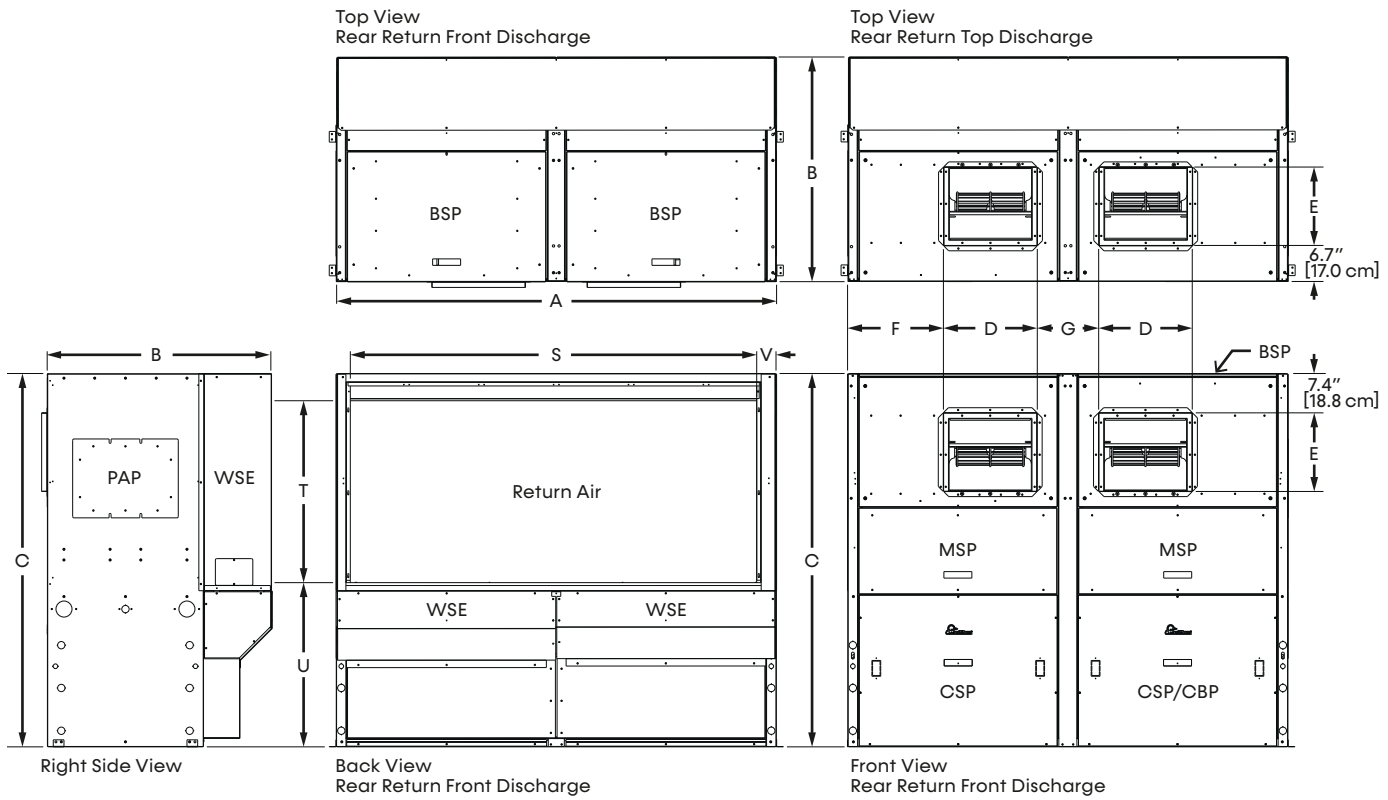

Notes:

All dimensions in table are inches (cm). See standard configuration for water connection and electrical knockout dimensions.

- While clear access to all removable panels may not be required, installer should take care to comply with all building codes and allow adequate clearance for future field service.
- Units require 3 feet (91 cm) of clearance for water connections, WSE coil air bleed, CBP, CSP, BSP, PAP, and MSP.
- Condensate drain is internally trapped, externally vented.
- For top discharge units, BSP is on front. For front discharge units, BSP is on top. Allow 3 feet above unit for service.

BSP = Blower Service Panel
 CSP = Compressor Service Panel
 CBP = Control Box Panel
 MSP = Motor Service Panel
 PAP = Pulley Access Panel
 WSE = Waterside Economizer

Models:
SB
072-300

SB300 Vertical Dimensional Data

Unit Size	Overall Cabinet			Discharge Connections Duct Flange				Water Connections				Electrical Knockouts			Return Air Connections Using Return Air Opening						
	A	B	C	D	E	F	G	K	L	M	N	O			P	Q	S	T	U	V	
	Width	Depth	Height	Supply Width	Supply Height	Side Offset	Center Offset	1	2	3	Connection Height	1	2	3	7/8" (2.2 cm)	Return Width	Return Height				
	1-3/8" (3.5cm)			Water In	Water Out	Condensate				Return Width		Return Height									
300	inch	82.3	29.2	69.8	17.5	14.7	6.3	8.6	25.8	3.4	14.6	24.2	3.0	11.0	19.0	13.0	0.9	77.2	35.0	31.0	2.6
	cm	209.0	74.2	177.3	44.5	37.3	16.0	21.8	65.5	8.6	37.1	61.5	7.6	27.7	48.3	33.0	2.3	196.1	88.9	78.7	6.6

Front View
Top Discharge

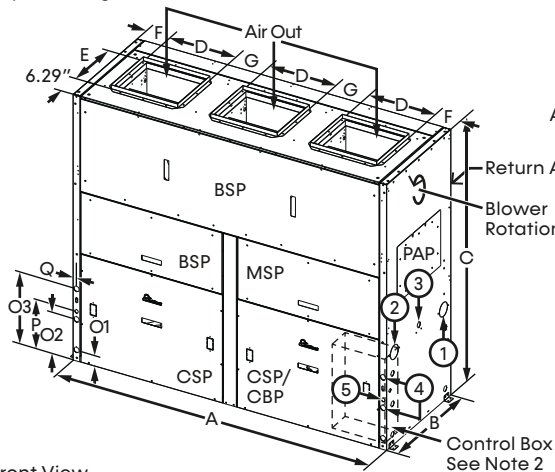

Right Side View
Straight Discharge

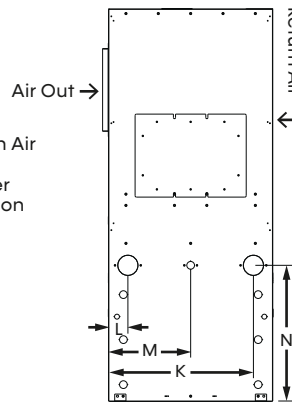

Rear Return
Top Discharge

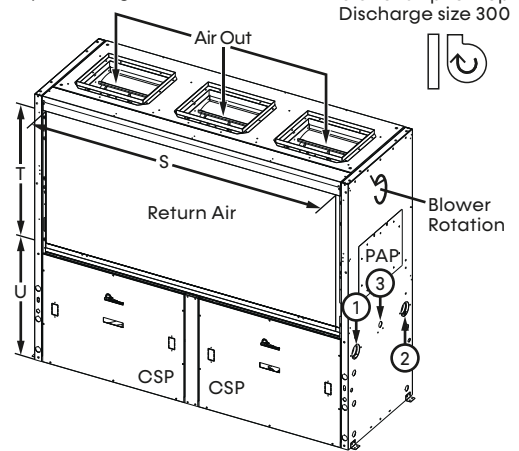

Blower to Air Coil
relationship for Top
Discharge size 300

Front View
Straight Discharge

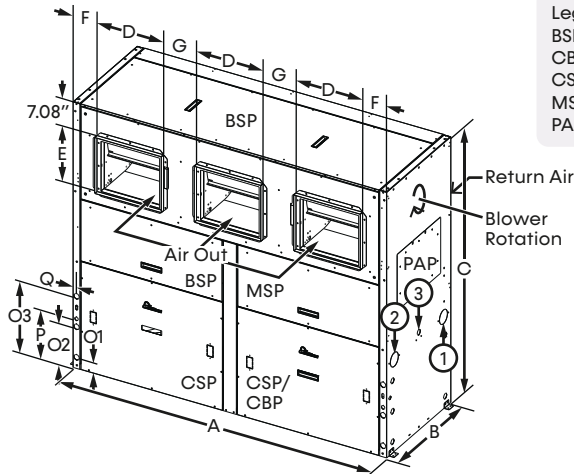

Legend

- BSP = Blower Service Panel
- CBP = Control Box Panel
- CSP = Compressor Service Panel
- MSP = Motor Service Panel
- PAP = Pulley Access Panel

Rear View
Straight Discharge

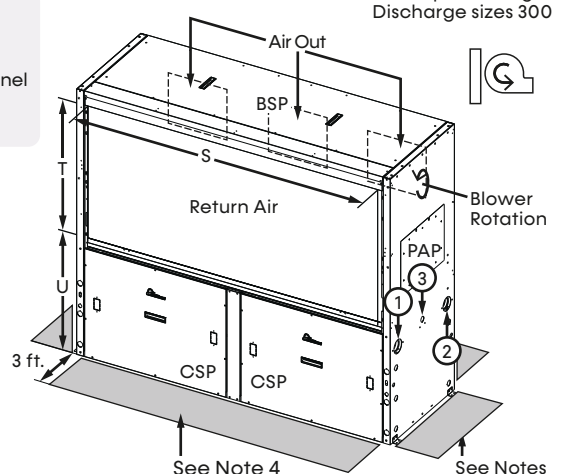

Blower to Air Coil
relationship for Straight
Discharge sizes 300

Notes:

All dimensions in table are inches (cm)

1. Condensate drain is available on either side (left or right) of unit. Drain hose and drain connection will be tied inside the unit. Installer will untie the drain hose, form trap, and connect to the condensate drain hole of installer's choice.
2. Electrical access is available on either side (left or right) of unit and is also available in the front on the left or right side of the unit.
3. Overall cabinet height and depth dimension does not include duct flange for or filter rails.
4. Units require 3 feet (91 cm) of clearance, CBP, CSP, MSP and BSP service access. While access to all removable panels may not be required, installer should take care to comply with all building codes and allow adequate clearance for future field service.
5. Filter removal is from right or left side of filter frame, allow 3 feet (91 cm) of access for servicing.

Legend	SB300
① Water Inlet	2-1/2" FPT
② Water Outlet	2-1/2" FPT
③ Condensate Drain ¹	1" FPT
④ High Voltage Access ²	1-3/8" (3.49 cm)
⑤ Low Voltage Access ²	7/8" (2.2 cm)

SB300 with WSE Vertical Dimensional Data

Unit Size	Overall Cabinet			Discharge Connections Duct Flange				Water Connections				Electrical Knockouts			Return Air Connections Using Return Air Opening						
	A	B	C	D	E	F	G	K	L	M	N	O			P	Q	S	T	U	V	
	Width	Depth	Height	Supply Width	Supply Height	Side Offset	Center Offset	1	2	3	Connection Height	1	2	3			Return Width	Return Height		Return Side Offset	
	inch	cm	inch	cm	inch	cm	inch	cm	inch	cm	inch	cm	inch	cm	inch	cm	inch	cm	inch	cm	inch
300	82.3	42.0	69.8	17.5	14.7	6.4	8.6	25.8	3.4	14.6	24.2	3.0	11.0	19.0	15.1	0.9	76.0	34.0	30.7	3.6	
	209.0	106.7	177.3	44.5	37.3	16.3	21.8	65.5	8.6	37.1	61.5	7.6	27.9	48.3	38.4	2.3	193.0	86.4	78.0	9.1	

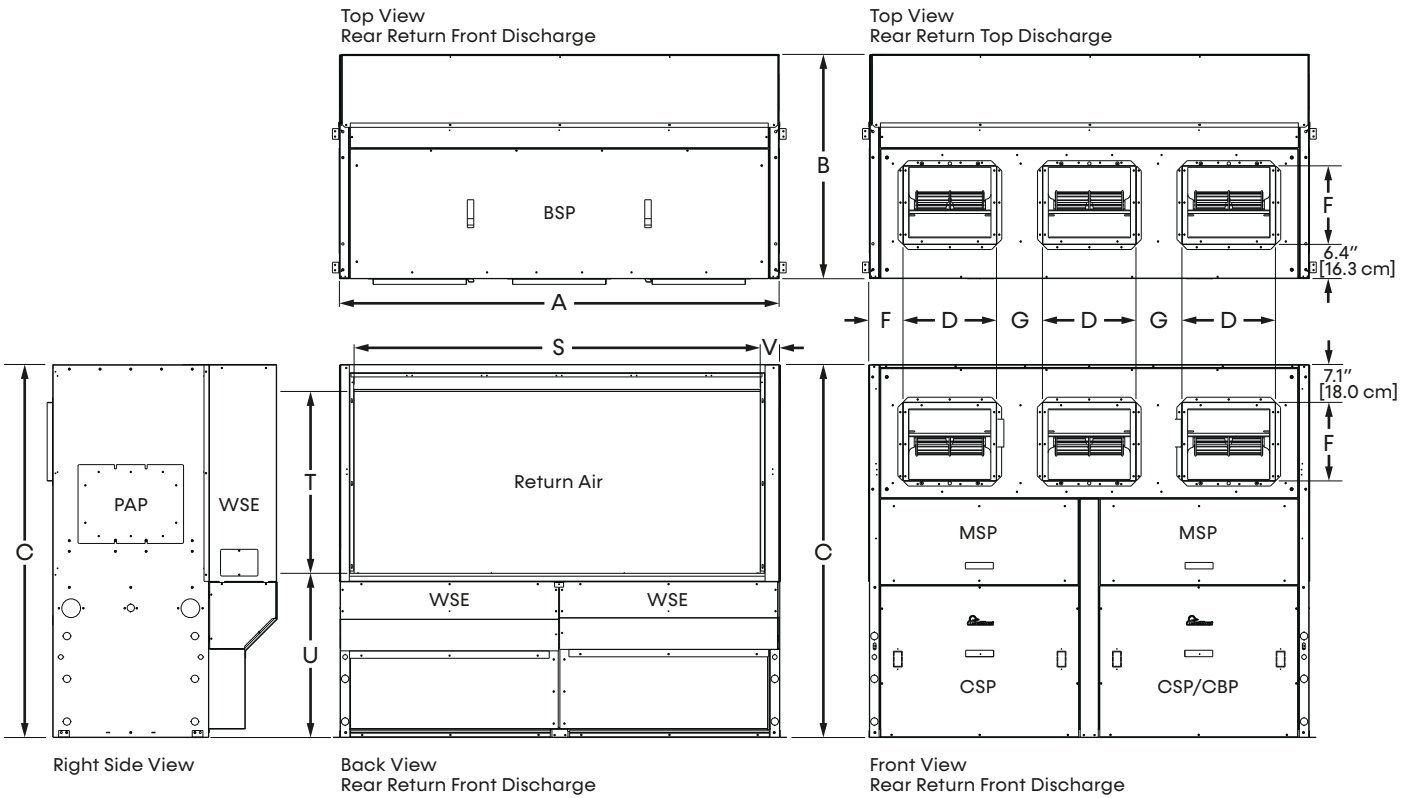

Notes:

All dimensions in table are inches (cm). See standard configuration for water connection and electrical knockout dimensions.

- While clear access to all removable panels may not be required, installer should take care to comply with all building codes and allow adequate clearance for future field service.
- Units require 3 feet (91 cm) of clearance for water connections, WSE coil air bleed, CBP, CSP, BSP, PAP, and MSP.
- Condensate drain is internally trapped, externally vented.
- For top discharge units, BSP is on front. For front discharge units, BSP is on the top. Allow 3 feet above unit for service.

- BSP = Blower Service Panel
- CSP = Compressor Service Panel
- CBP = Control Box Panel
- MSP = Motor Service Panel
- PAP = Pulley Access Panel
- WSE = Waterside Economizer

Models:
SB
072-300

Horizontal Installation

HORIZONTAL UNIT LOCATION

Units are not designed for outdoor installation. Locate the unit in an INDOOR area that allows enough space for service personnel to perform typical maintenance or repairs without removing unit from the ceiling. Horizontal units are typically installed above a false ceiling or in a ceiling plenum. Never install units in areas subject to freezing or where humidity levels could cause cabinet condensation (such as unconditioned spaces subject to 100% outside air). Consideration should be given to access for easy removal of the filter and access panels. Provide sufficient room to make water, electrical, and duct connection(s). Allow 3-foot (91 cm) clearance for servicing unit through all access panels.

If the unit is located in a confined space, such as a closet, provisions must be made for return air to freely enter the space by means of a louvered door, etc. Any access panel screws that would be difficult to remove after the unit is installed should be removed prior to setting the unit. Refer to Figure 2 for an illustration of a typical installation. Refer to unit submittal data or engineering design guide for dimensional data.

Conform to the following guidelines when selecting unit location:

1. Provide a hinged access door in concealed spline or plaster ceilings. Provide removable ceiling tiles in T-bar or lay-in ceilings. Refer to horizontal unit dimensions for specific series and model in the unit's Product Catalog. Size the access opening to accommodate the service technician during the removal or replacement of the compressor, control, or blower assembly. Provide access to hanger brackets, water valves and fittings. Provide screwdriver clearance to access panels, discharge collars and all electrical connections.
2. DO NOT obstruct the space beneath the unit with piping, electrical cables and other items that prohibit future removal of components or the unit itself.
3. Use a manual portable jack/lift to lift and support the weight of the unit during installation and servicing.

The installation of water source heat pump units and all associated components, parts and accessories which make up the installation shall be in accordance with the regulations of ALL authorities having jurisdiction and MUST conform to all applicable codes. It is the responsibility of the installing contractor to determine and comply with ALL applicable codes and regulations.

NOTE: Minimum clearances for installation are the same as the minimum required service clearances. Consult the service clearances or reference of installation clearances for more information.

MOUNTING HORIZONTAL UNITS

Horizontal units have four hanger brackets partially attached at the factory, one at each corner. Enclosed within the unit there is a hanger kit hardware bag containing vibration isolation grommets, washers, screws and a hanger installation instruction page. One additional screw from the hardware bag must be added to each hanger bracket before unit installation. Tighten each screw to 75 in-lbs (8.5 Nm). See Figure 1. Refer to the hanger installation instruction page contained in the hardware bag for details of final hanger bracket attachment and unit suspension.

Use four (4) field-supplied threaded rods and factory-provided vibration isolators to suspend the unit. Safely lift the unit into position supporting the bottom of the unit. Ensure the top of the unit is not in contact with any external objects. Connect the top end of the four all-thread rods, slide rods through the brackets and grommet then assemble washers and double nuts at each rod. Ensure that the unit is approximately level and that the threaded rod extends past the nuts.

Pitch the unit toward the drain as shown in Horizontal Unit Pitch to improve the condensate drainage.

Horizontal Installation

Figure 1: Hanger Bracket

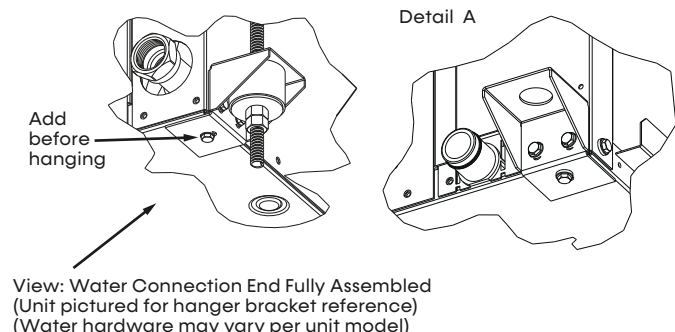

HORIZONTAL UNIT PITCH

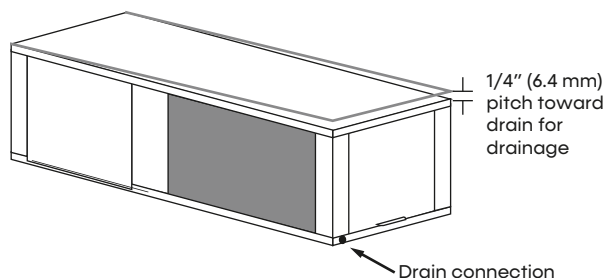
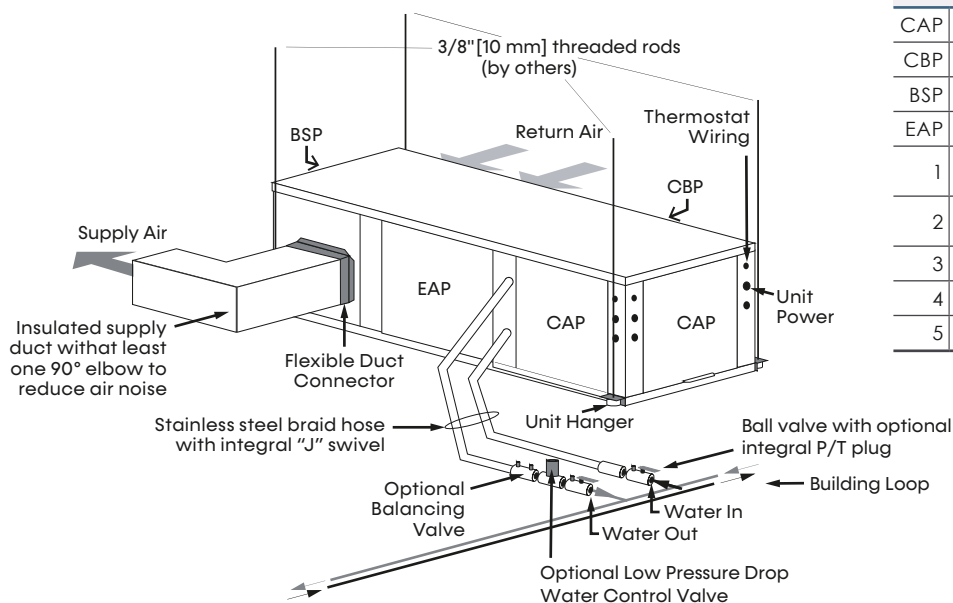

Figure 2: Typical Unit Installation



Legend inch (cm)	
CAP	= Compressor Access Panel
CBP	= Control Box Panel
BSP	= Blower Service Panel
EAP	= Expansion Valve Access Panel
1	= Water Outlet - 1-1/4 (3.2) FPT (072-096) 1-1/2 (3.8) FPT (120)
2	= Water Inlet - 1-1/4 (3.2) FPT (072-096) 1-1/2 (3.8) FPT (120)
3	= Condensate 3/4 (1.9) FPT
4	= High Voltage 1-1/8 (2.9) KO
5	= Low Voltage 7/8 (2.2) KO

Notes:

1. Service access is required for all removable panels and installer should take care to comply with all building codes and allow adequate clearance for future field service.
2. Water inlet and water outlet connections are available on either side (left or right) of the unit. Qty (2x) MPT Plugs are shipped loose in a plastic bag tied to the water leg in front of the unit. Installer must plug water inlet/outlet side not being connected to.
3. Condensate drain is 3/4-inch FPT and is located on cabinet end opposite the compressor.
4. Electrical access is available on either side (left or right) of the front.
5. Electric box is on right side. It can be field converted to left side. Conversion should only be attempted by qualified service technician. If electric box relocated to opposite side, and water connected to opposite side, then this access is not required.
6. Units require 3 feet (90.1 cm) of clearance for water connections, CAP, CBP, EAP, and BSP service access.
7. Overall cabinet width dimensions does not include filter rail and duct flange.
8. Units are shipped with air-filter rails that are not suitable for supporting return air ductwork. An air-filter frame with duct-mounting collar is available as an accessory.

AIR COIL

To obtain maximum performance, the air coil should be cleaned before startup. A 10% solution of dishwasher detergent and water is recommended for both sides of the coil. A thorough water rinse should follow. **Do not use ultraviolet-based anti-bacterial systems.**

NOTICE

Installation Note - Ducted Return: Many horizontal WSHPs are installed in a return air ceiling plenum application (above ceiling). Vertical WSHPs are commonly installed in a mechanical room with free return (e.g. louvered door). Filter rails are the industry standard and are included on commercial heat pumps only for holding the filter. For ducted return applications, the filter rail must be removed and replaced with a duct flange or filter frame. Canvas or flexible connectors should also be used to minimize vibration between the unit and ductwork.

Models:
SB
072-300

Horizontal Installation

CONDENSATE PIPING

A condensate drain line must be installed and pitched away from the unit to allow for proper drainage. This connection must meet all local plumbing/building codes.

Pitch the unit toward the drain as shown in Figure 3 to improve the condensate drainage. On small units (less than 2.5 tons/8.8 kW), ensure that unit pitch does not cause condensate leaks inside the cabinet.

Install condensate trap at each unit with the top of the trap positioned below the unit condensate drain connection as shown in Horizontal Unit Pitch. Design the depth of the trap (water-seal) based upon the amount of ESP capability of the blower (where 2 inches [51 mm] of ESP capability requires 2 inches [51 mm] of trap depth). As a general rule, 1½-inch [38 mm] trap depth is the minimum.

Each unit must be installed with its own individual trap and connection to the condensate line (main) or riser. Provide a means to flush or blow out the condensate line. DO NOT install multiple units with a common trap and/or vent.

Always vent the condensate line when dirt or air can collect in the line or a long horizontal drain line is required. Also vent when large units are working against higher external static pressure than other units connected to the same condensate main since this may cause poor drainage for all units on the line. **WHEN A VENT IS INSTALLED IN THE DRAIN LINE, IT MUST BE LOCATED AFTER THE TRAP IN THE DIRECTION OF THE CONDENSATE FLOW.**

STANDARD & STAINLESS STEEL DRAIN PANS

The condensate connection is female pipe thread. Field-provided male adapter required for condensate drain connection.

Figure 3: Horizontal Condensate Connection

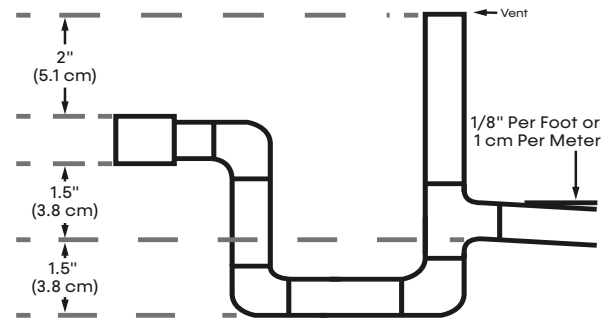

CAUTION

Ensure condensate line is pitched toward drain 1/8 inch per foot [11 mm per m] of run.

Figure 4: Right Return Side Discharge to Back

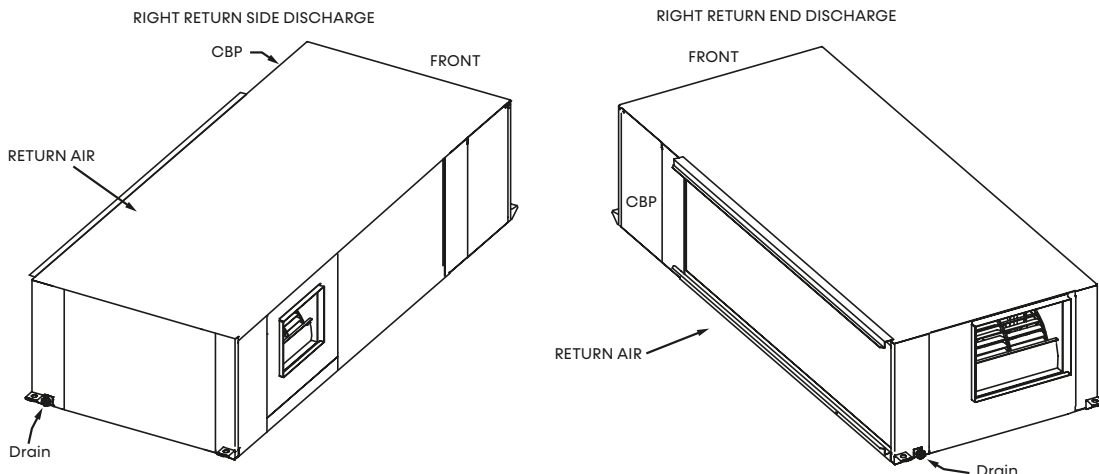

Horizontal Installation

DUCT SYSTEM INSTALLATION

Proper duct sizing and design is critical to the performance of the unit. The duct system should be designed to allow adequate and even airflow through the unit during operation. Air flow through the unit **MUST** be at or above the minimum rated airflow for a given unit size to avoid equipment damage. Duct systems should be designed for quiet operation. Refer to Figure 2 for horizontal duct system details or Figure 5 for vertical duct system details. A flexible connector is recommended for both discharge and return air duct connections on metal duct systems to eliminate the transfer of vibration to the duct system. To maximize sound attenuation of the unit blower, the supply and return plenums should include internal fiberglass duct liner or be constructed from ductboard for the first few feet. Application of the unit to uninsulated ductwork in an unconditioned space is not recommended, as the unit's performance may be adversely affected.

At least one 90-degree elbow should be included in the supply duct to reduce air noise. If air noise or excessive air flow is a problem, the blower speed can be changed. For airflow charts, consult submittal data for the series and model of the specific unit.

If the unit is connected to existing ductwork, a previous check should have been made to ensure that the ductwork has the capacity to handle the airflow required for the unit. If ducting is too small, as in the replacement of a heating only system, a larger ductwork should be installed. All existing ductwork should be checked for leaks and repaired as necessary.

An unventilated area where water source heat pump is installed and surpasses a R-454B refrigerant charge of 62 oz (1.76 kg), shall be without continuously operating open flames (for example an operating gas appliance) or other **POTENTIAL IGNITION SOURCES** (for example an operating electric heater, hot surfaces).

Only auxiliary electric heaters approved by ClimateMaster shall be installed in connecting ductwork. The installation of any other auxiliary devices is beyond ClimateMaster's responsibility.

For duct-connected units, false ceilings or drop ceilings may be used as a return air plenum as long as the ClimateMaster RDS is installed as shown in Figure 15.

WARNING

Ducts connected to an appliance shall not contain a **POTENTIAL IGNITION SOURCE**.

WARNING

Keep any required ventilation openings clear of obstruction.

WARNING

For mechanical ventilation, the lower edge of the air extraction opening where air is exhausted from the room shall not be more than 3.94 inches (100 mm) above the floor. The location where the mechanical ventilation air extracted from the space is discharged shall be separated by a sufficient distance, but not less than 9.84 feet (3 m), from mechanical ventilation air intake openings, to prevent recirculation to the space.

Models:
SB
072-300

Horizontal Field Conversion of Air Discharge

WARNING

To prevent injury or death from electrical shock, disconnect electrical power source.

OVERVIEW

Horizontal units can be field converted between straight (side) and back (end) discharge using the instructions below.

NOTE: It is not possible to field convert return air between left or right return models due to the necessity of refrigeration copper piping changes.

PREPARATION

Field conversion must be completed on the ground. If the unit is already hung, it should be taken down for the field conversion. Place in a well-lighted area. Conversion should only be attempted by a qualified service technician.

SIDE-TO-BACK DISCHARGE CONVERSION

1. Remove back panel and side access panel
2. Loosen two motor-slide nuts, raise motor-slide assembly and remove belt and motor sheave.
3. Remove blower sheave. Remove motor bolts and carefully remove motor.
4. Remove two motor clips and reattach to opposite side.
5. Unbolt (three per side) complete housing assembly.
6. Rotate complete assembly into new position. Locate over mounting holes in base, reattach using three bolts per side.
7. Mount motor, motor sheave, blower sheave and belt. Make sure wires are not pinched and not over sharp edges. Adjust motor downward to tighten belt. Raise or lower motor slide assembly with adjusting bolt and retighten two slide nuts. Check for correct tension (See Tensioning V-Belt Drives page). Rewire motor (at contactor) for correct rotation. Spin blower wheel to ensure wheel is not obstructed.
8. Replace two panels.

BACK-TO-SIDE DISCHARGE CONVERSION

If the discharge is changed from back to side, use Side-to-Back conversion steps noting that illustrations are reversed.

LEFT VERSUS RIGHT RETURN

It is not possible to field convert return air between left or right return models due to the necessity of refrigeration copper piping changes. However, the conversion process of side to back or back to side discharge for either right or left return configuration is the same. In some cases, it may be possible to rotate the entire unit 180 degrees if the return air connection needs to be on the opposite side. Rotating the unit moves the piping to the other end of the unit.

Step 1: Remove Blower Panel and Access Panel

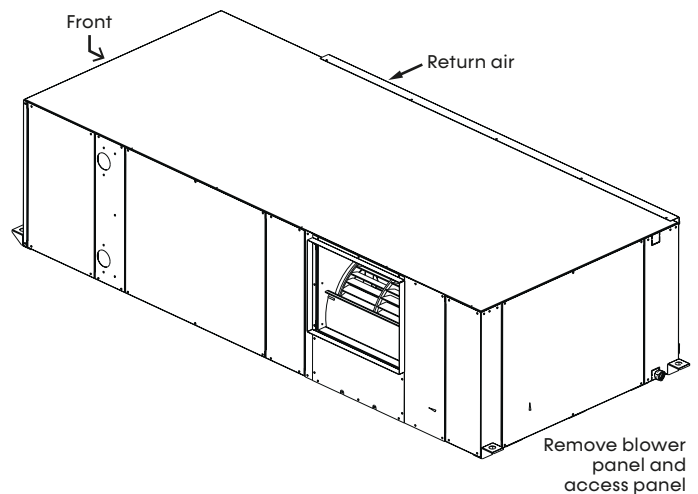

Step 2: Access Blower Housing Assembly

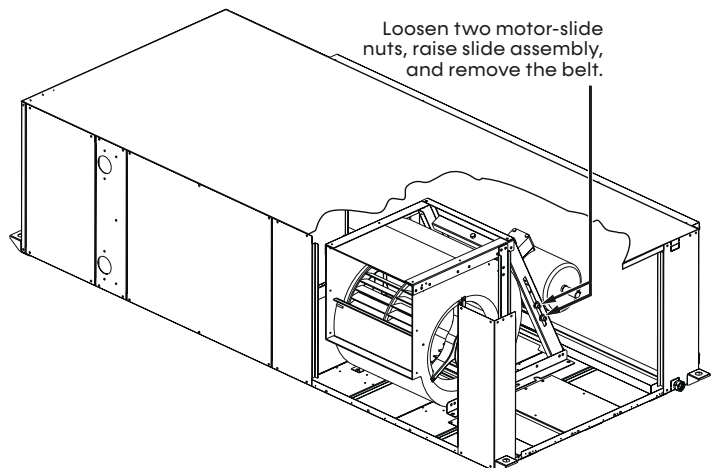

Horizontal Field Conversion of Air Discharge

Step 3: Prepare Blower Housing Assembly

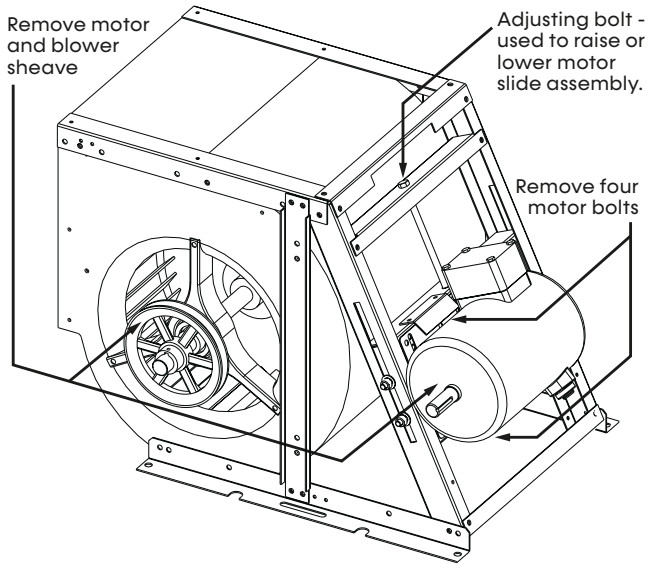

Step 5: Remove Bolts

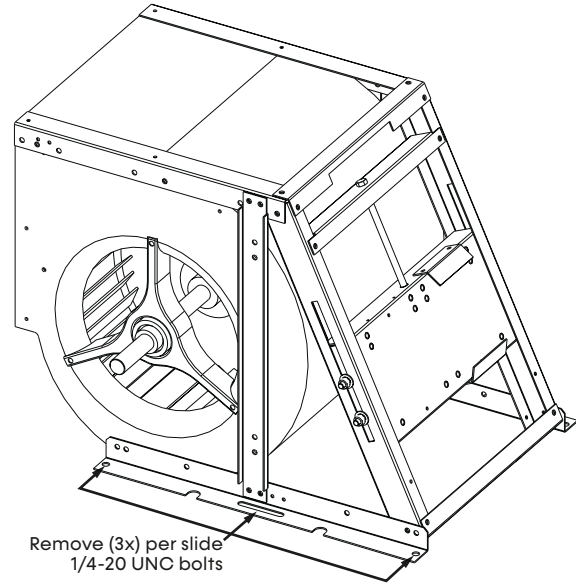

Step 4: Change Motor Clip Orientation

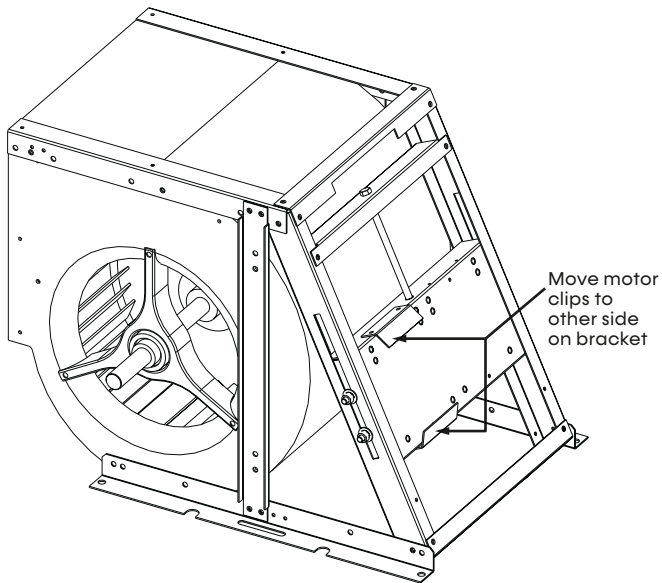

Step 6: Rotate Blower Housing and Bolt Down

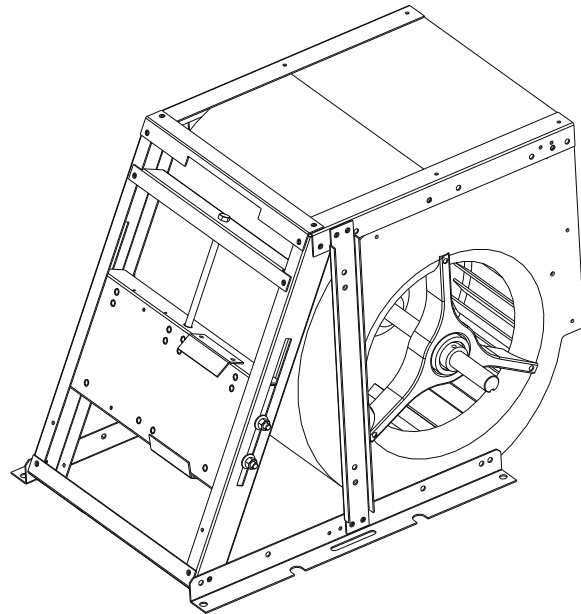

Rotate entire blower housing assembly to rest at back end of the unit. Locate housing holes and bolt down using previous 1/4-20 UNC bolts (3x) each side.

Models:
SB
072-300

Horizontal Field Conversion of Air Discharge

Step 7: Secure Motor, Motor Sheave, Blower Sheave, and Belt

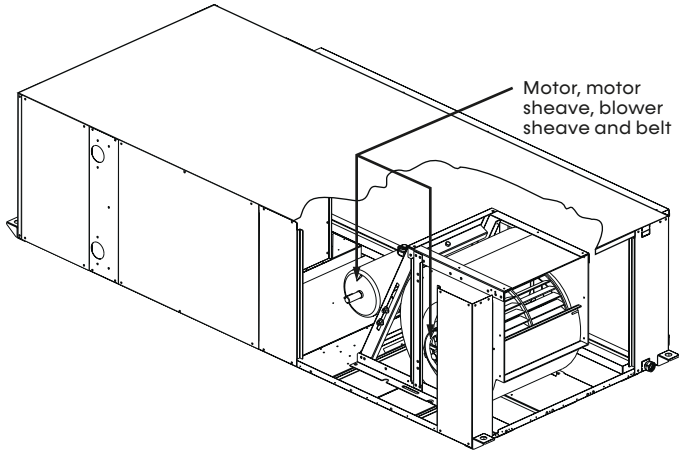

Step 8: Secure Blower Panel and Access Panel

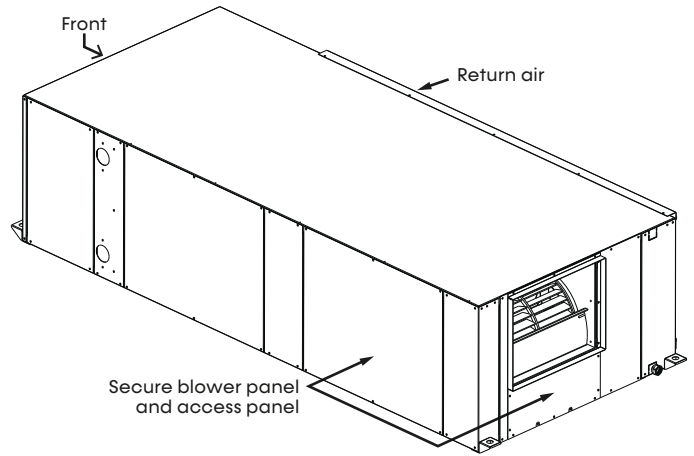

Vertical Installation

VERTICAL LOCATION AND ACCESS

SB units are not designed for outdoor installation. Locate the unit in an INDOOR area that allows enough space for installation and for service personnel to perform typical maintenance or repairs. SB units are typically installed in a floor level closet or in a small mechanical room. Refer to the figure below for an illustration of a typical installation. Install units with adequate clearance to allow maintenance and servicing. **NOTE: Minimum clearances for installation are the same as the minimum required service clearances. Consult the service clearances on for reference of installation clearances.** Conform to the following guidelines when selecting unit location:

- Provide adequate clearance for filter replacement and drain pan cleaning. DO NOT block filter access with piping, conduit or other materials. Refer to the product catalog for unit dimensions.
- Provide access for fan and fan motor maintenance and for servicing of the compressor and coils without removal of the unit.
- Provide an unobstructed path to the unit within the closet or mechanical room to enable removal of the unit if necessary.
- Provide access to water valves and fittings, and screwdriver access to the unit side panels, discharge collar and all electrical connections

DUCT SYSTEM DESIGN AND INSTALLATION GUIDELINES

The following application guidelines must be used when installing the Tranquility SB. Failure to follow these guidelines could result in unsatisfactory unit performance and/or premature failure of some unit components. ClimateMaster will not warranty, or accept responsibility for products which fail, have defects, damage or insufficient performance as a result of improper application.

- The duct system must be sized to handle the airflow quietly and must not exceed the maximum allowable External Static Pressure. To maximize sound attenuation, metal supply and return ducts should include internal insulation or be of duct-board construction for the first 10 feet or end of first full-sized elbow.
- Install a flexible connector in all supply and return air ducts close to the unit to inhibit sound transfer to the ducts.
- Do not install uninsulated ducts in an unconditioned space. The unit performance will be adversely affected and damage from condensate can occur.

Figure 5: Typical Vertical Installation

Rear Return/Top Discharge shown

Refer to Dimensional Data pages for other arrangements & dimensions

Ductwork not shown.

All components external of unit are field supplied.

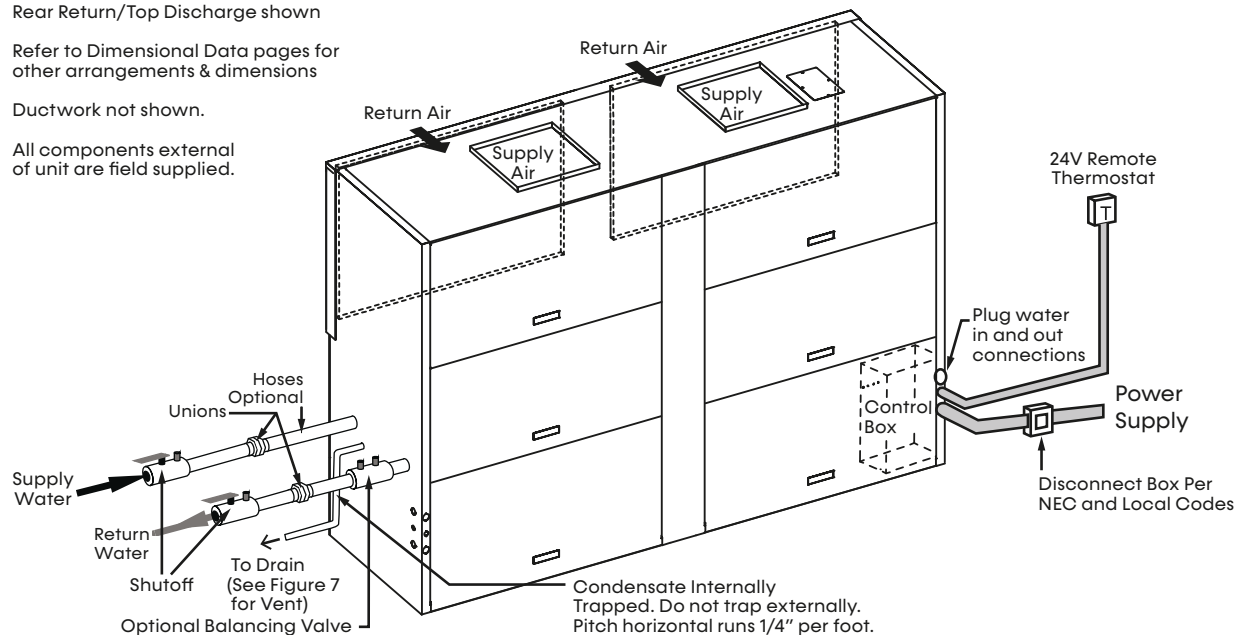

Models:
SB
072-300

Vertical Field Conversion of Air Discharge (072-120)

WARNING

To prevent injury or death from electrical shock, disconnect electrical power source.

OVERVIEW

Vertical unit sizes 072-120 can be field converted between top and straight (side) discharge and back (end) discharge using the instructions below.

NOTE: Field conversion of discharge air is not available in vertical unit sizes 168 to 300. Be sure to order your unit with the proper discharge air configuration.

PREPARATION

Place in a well-lit area. Conversion should only be attempted by qualified service technicians.

NOTE: To convert from straight discharge to top discharge, reverse the following steps.

Step 1: Remove Panels

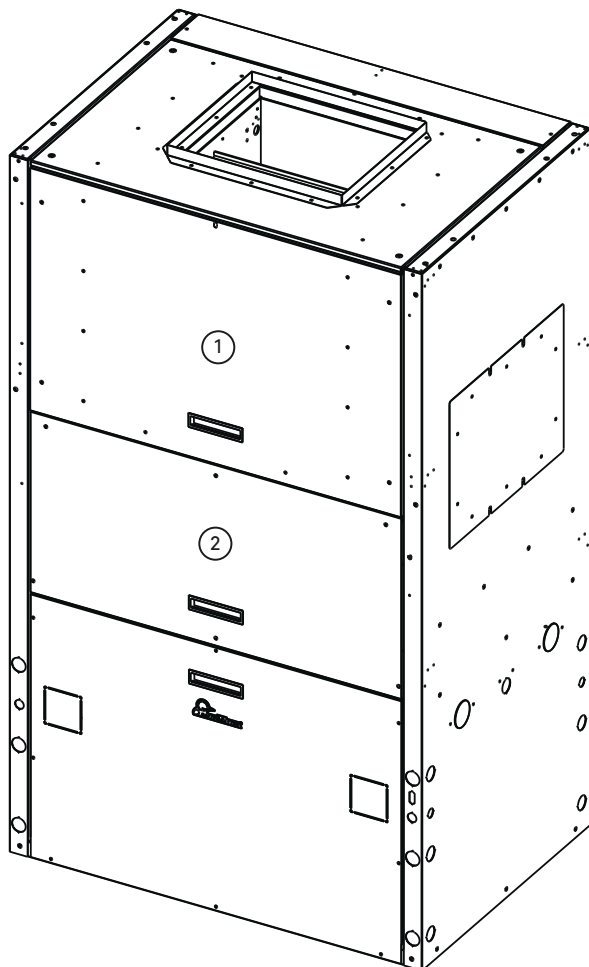

Step 2: Remove Screws

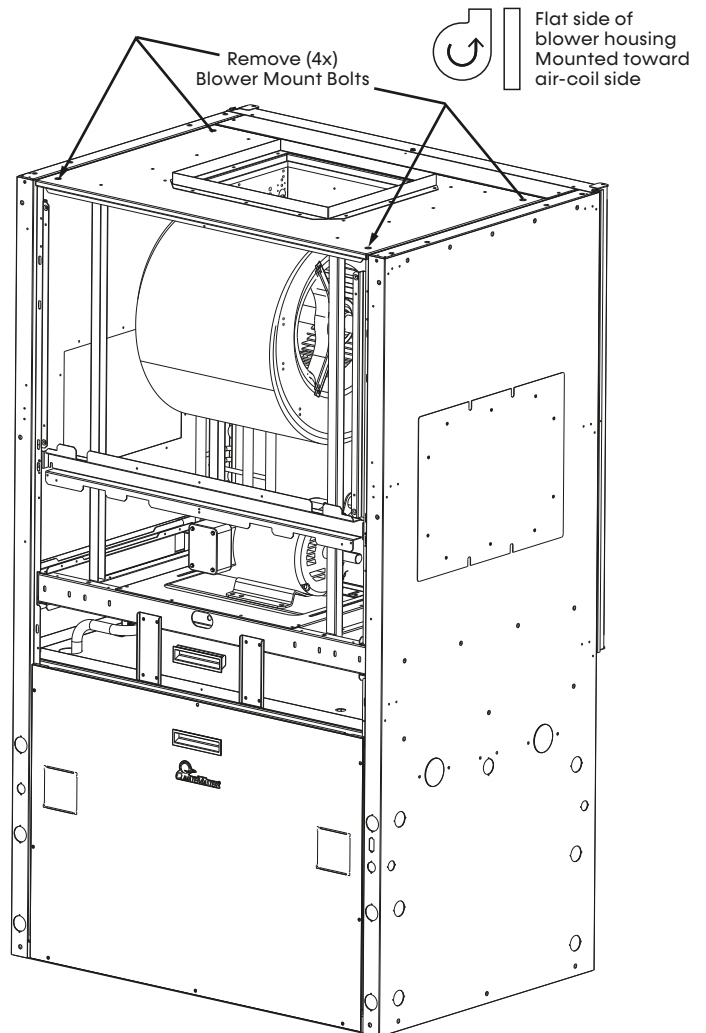

Vertical Field Conversion of Air Discharge (072-120)

Step 3: Rotate and reattach blower



Tilt blower and panel forward 90°



Rotate blower and panel 180°

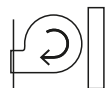

Flat side of blower housing mounted towards motor side

Replace (4x) Blower Mount Bolts

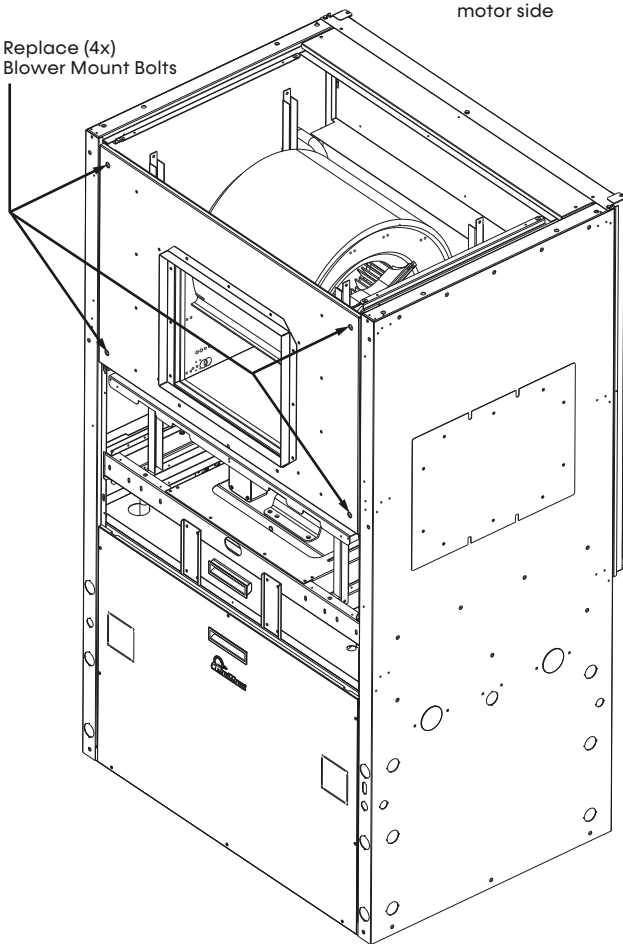

Step 4: Replace and Secure Panels

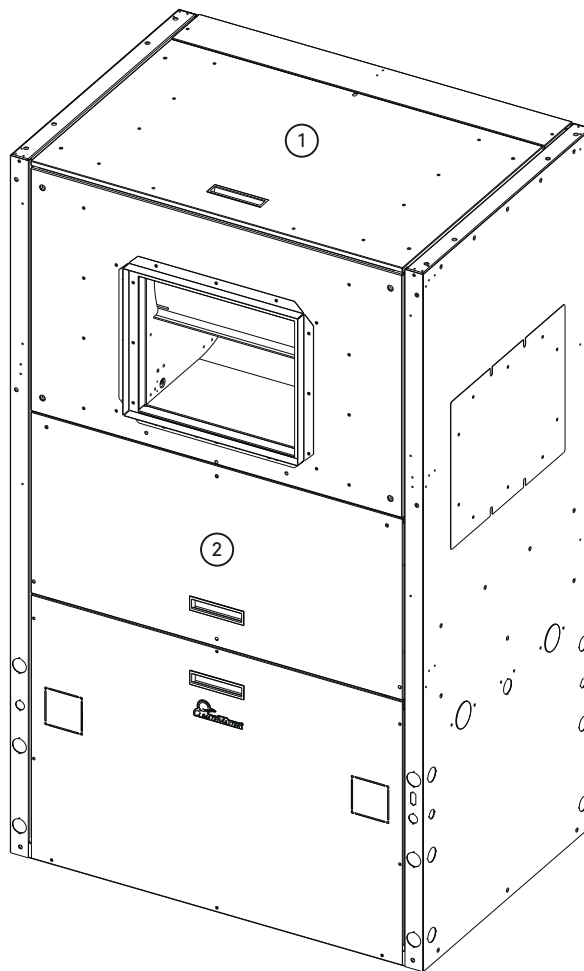

Models:
SB
072-300

Vertical Field Conversion of Control Box (072-300)

WARNING

To prevent injury or death from electrical shock, disconnect electrical power source.

NOTICE

You must provide three feet service access (or meet code requirements) for the new control box location.

OVERVIEW

The vertical unit control box can be field converted from front to any other corner for unit sizes 168-300, or opposite corner (water coil side) for unit sizes 072-120.

PREPARATION

Place in a well-lit area. Conversion should only be attempted by a qualified service technician.

Step 1: Remove Panels (SB168-300)

Remove panels 1-6 and dividers necessary to reroute wires to new control box location.

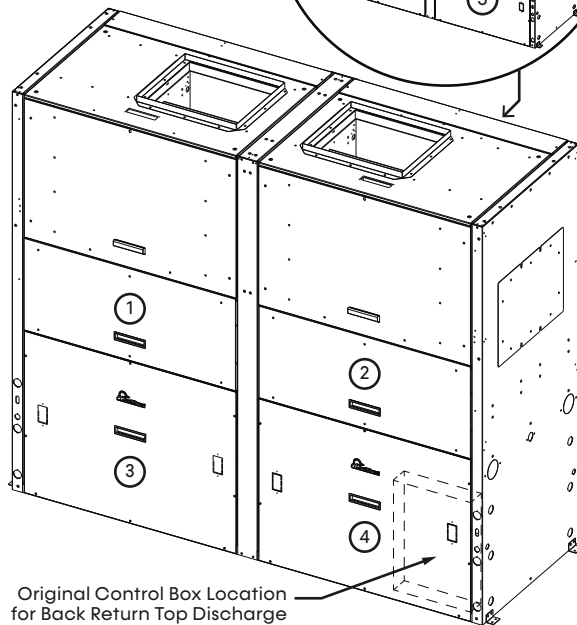
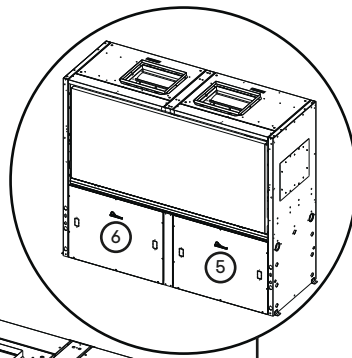

Original Control Box Location for Back Return Top Discharge

Note: SB168-240 chassis shown.

Step 1: Remove Panels (SB072-120)

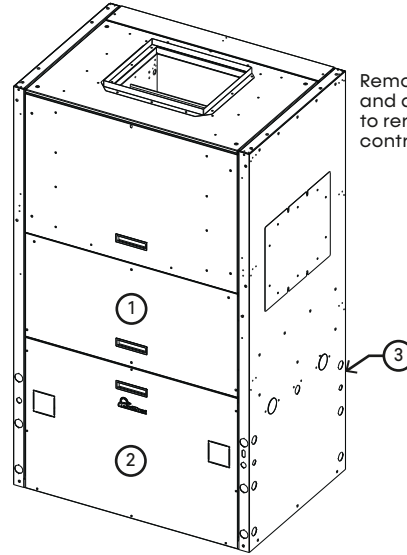

Remove panels 1-3 and dividers necessary to reroute wires to new control box location.

NOTE: After completing step 1, follow steps 2-7 for all sizes.

Step 2: Tag and detach all wires from components, pull wires out of control box, then remove the control box.

Step 3: Attach box to new location.

Step 4: Reroute wires.

NOTE: Keep wires away from hot lines and sharp edges.

Step 5: Reattach wires.

NOTE: On units with two compressors, reattach Circuit 1 to the same compressor so that the compressor configuration does not change. Only the location of the control box should change.

Step 6: Verify wiring in the unit matches the configuration wiring diagram.

Step 7: Replace panels.

Vertical Field Conversion of Water Connections (072-240)

Models:
SB
072-300

⚠ WARNING

To prevent injury or death from electrical shock, disconnect electrical power source.

OVERVIEW

For vertical unit sizes 072-240, the water connection can be field converted to opposite side. Connections can be both left, right, or one on each side.

NOTE: Field Conversion of Water Connections is not available on unit size 300. Be sure to order the proper water-connection hand configuration.

PREPARATION

Field conversion must be completed on the ground. If the unit is already hung it should be taken down for the field conversion. Place in a well-lit area. Conversion should only be attempted by a qualified service technician.

Left or Right Side-to-Back Discharge Conversion

NOTE: Water connection direction is determined when facing the motor side of the unit:

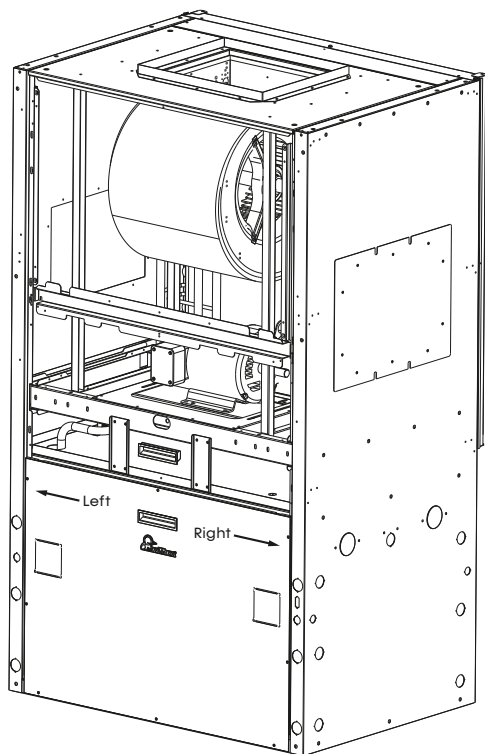

Step 1: Remove panels needed for access to water connections.

Step 2: Remove screws from side panels. Loosen (4x) screws in slots but do not remove.

Step 3: Both water in and out have a union centered in the middle of the unit. Undo both unions, rotate the water legs for opposite configuration, retighten unions, then reattach connection flanges to wrappers. Use slots to adjust and retighten screws in slots.

Step 4: Replace panels.

Step 5: Ensure wiring is per wire diagram.

Models:
SB
072-300

Vertical Condensate Installation

CONDENSATE PIPING

Remove KO on the side to which that drain will be connected. Remove access panels. Inside the unit, untie and uncoil drain hose. Form a trap in the hose ensuring the hose is not kinked or deformed. Connect plate assembly to the side frame with two screws.

Outside of unit, connect 1-inch MPT fitting to the plate assembly. Run the line to building drain. Horizontal runs must be pitched ¼ inch per foot (10 mm per 46 cm) toward drain. Do not trap externally.

The figure below illustrates a typical trap and vent used with the Tranquility SB.

Figure 6: SB Vertical Condensate Piping

All fittings and tubing outside of the unit are field supplied.

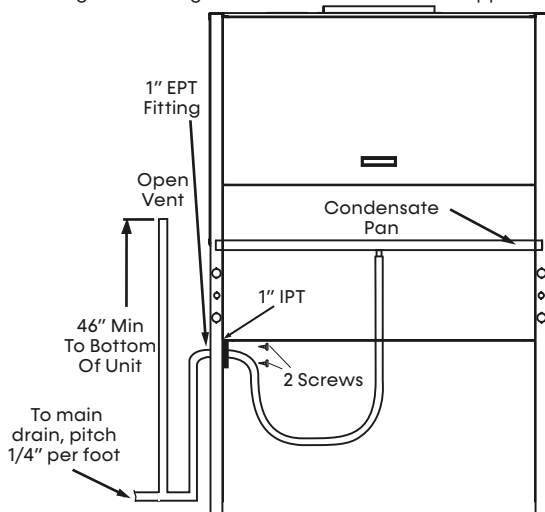

Each unit must be installed with its own individual line to the building's main condensate drain line or riser. Provide a means to flush or blow out the condensate line. **DO NOT** install units with a common trap and or vent. Always vent the condensate line when dirt or air can collect in the line or a long horizontal drain line is required. Also vent when large units are working against higher external-static pressure than other units connected to the same condensate main since this may cause poor drainage for all units on the line. **WHEN A VENT IS INSTALLED IN THE DRAIN LINE, IT MUST BE LOCATED AFTER THE TRAP IN THE DIRECTION OF THE CONDENSATE FLOW** and opening 46 inches (117 cm) minimum from bottom of unit. Vent the condensate piping per code.

WARNING

Ensure condensate line is pitched toward drain ¼ inch per foot [10mm per 46cm] of run.

Horizontal and Vertical Installations – Drain main or riser must be sized for all units connected to it.

Pipe Size inch (mm)	Connected Tons	Connected kW
3/4 (19)	<4	<14
1 (25)	<6	<21
1-1/4 (32)	<30	<105
1-1/2 (38)	<50	<175
2 (51)	<150	<527
3 (76)	<300	<1055
4 (102)	<500	<1758

Ensure all connections are secure and water tight.

After drain is connected to main and all drain connections are secure and water tight, pour one gallon of water into condensate pan. The water should drain out freely. Repair any leaks.

- On units with multiple fan outlets a “pair of pants” duct connection must be used for proper air balance and distribution and to prevent fan oscillation.
- Include at least one 90-degree turn in supply air ducts to reduce noise transmission.
- Existing ducts must be checked to ensure proper size and configuration prior to installation of any replacement unit. Also inspect for and repair all air leaks in existing ducts.
- Units may only be connected to a dedicated duct system. Consult the factory BEFORE connecting multiple units to a common duct system.
- Never connect a unit to a duct system with automatic or modulating dampers, VAV boxes, etc. in the supply air system. Never allow a situation where the total unit CFM can drop below the minimum required for proper unit operation.
- Never connect a bypass damper from the supply air duct to the return air duct. Never allow the return air temperature to drop below the minimum allowable normal temperature for proper unit operation.
- Do not use SB units for 100% outdoor air treatment. Do not add hot-gas-bypass to “convert” a unit for outdoor air treatment. Always use a dedicated outdoor air unit for outdoor air treatment.
- Do not exceed 10% of the total unit CFM with untreated outdoor air.

Piping Installation

INSTALLATION SUPPLY AND RETURN PIPING

Follow these piping guidelines:

1. Install a drain valve at the base of each supply and return riser to facilitate system flushing.
2. Install shut-off/balancing valves and unions at each unit to permit unit removal for servicing.
3. Place strainers at the inlet of each system circulating pump.
4. Select the proper hose length to allow slack between connection points. Hoses may vary in length by +2% to -4% under pressure.
5. Refer to Table 2. Do not exceed the minimum bend radius for the hose selected. Exceeding the minimum bend radius may cause the hose to collapse, which reduces water flow rate. Install an angle adapter to avoid sharp bends in the hose when the radius falls below the required minimum.

Insulation is not required on loop water piping except where the piping runs through unheated areas, outside the building or when the loop water temperature is below the minimum expected dew point of the pipe ambient conditions. Insulation is required if loop water temperature drops below the dew point (insulation is required for ground loop applications in most climates).

Pipe-joint compound is not necessary when water thread sealant tape is pre-applied to hose assemblies or when flared-end connections are used. If pipe-joint compound is preferred, use compound only in small amounts on the external pipe threads of the fitting adapters. Prevent sealant from reaching the flared surfaces of the joint.

NOTE: When antifreeze is used in the water loop, ensure that it is compatible with the thread-sealant tape or pipe-joint compound that is applied.

Maximum allowable torque for brass fittings is 30 ft-lbs [41 N-m]. If a torque wrench is not available, tighten finger-tight plus one quarter turn. Tighten steel fittings as necessary.

Optional pressure-rated hose assemblies designed specifically for use with ClimateMaster units are available. Similar hoses can be obtained from alternate suppliers. Supply and return hoses are fitted with swivel-joint fittings at one end to prevent kinking during installation.

The figure below illustrates a typical supply/return hose kit. Adapters secure hose assemblies to the unit and risers. Install hose assemblies properly and check regularly to avoid system failure and reduced service life.

⚠ WARNING

Polyolester Oil, commonly known as POE oil, is a synthetic oil used in many refrigeration systems including those with R-454B refrigerant. POE oil, if it ever comes in contact with PVC or CPVC piping, may cause failure of the PVC/CPVC. PVC/CPVC piping should never be used as supply or return water piping with water source heat pump products containing R-454B as system failures and property damage may result.

⚠ CAUTION

Corrosive system water requires corrosion resistant fittings and hoses, and may require water treatment.

⚠ CAUTION

Do not bend or kink supply lines or hoses.

⚠ CAUTION

Piping must comply with all applicable codes.

⚠ NOTICE

Do not allow hoses to rest against structural building components. Compressor vibration may be transmitted through the hoses to the structure, causing unnecessary noise complaints.

Table 2: Metal Hose Minimum Bend Radii

Hose Diameter	Minimum Bend Radii
1/2" [12.7 mm]	2-1/2" [6.4 cm]
3/4" [19.1 mm]	4" [10.2 cm]
1" [25.4 mm]	5-1/2" [14 cm]
1-1/4" [31.8 mm]	6-3/4" [17.1 cm]

Figure 7: Supply/Return Hose Kit

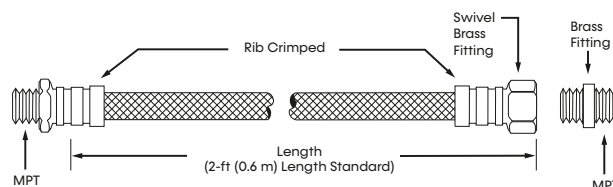

Models:
SB
072-300

Water-Loop Heat Pump Applications

COMMERCIAL WATER-LOOP APPLICATIONS

Commercial systems typically include a number of units connected to a common piping system. Any unit plumbing maintenance work can introduce air into the piping system; therefore air elimination equipment is a major portion of the mechanical room plumbing. Consideration should be given to insulating the piping surfaces to avoid condensation. The manufacturer recommends piping insulation any time the water temperature is below 60°F (15.6°C). Metal to plastic threaded joints should never be used due to their tendency to leak over time.

Water thread sealant tape or thread sealant is recommended to minimize internal fouling of the heat exchanger. Do not over tighten connections and route piping so as not to interfere with service or maintenance access. Hose kits are available from the manufacturer in different configurations for connection between the unit and the piping system. Depending upon selection, hose kits may include shut off valves, P/T plugs for performance measurement, high pressure stainless steel braided hose, "Y" type strainer with blow down valve, and/or with blow down valve, auto-flow valve and swivel connections.

The piping system should be flushed to remove dirt, piping chips, and other foreign material prior to operation (see Piping System Cleaning and Flushing in this manual). The flow rate is usually set between 2.25 and 3.5 GPM per ton (2.9 and 4.5 l/m per kW) of cooling capacity. The manufacturer recommends 3 GPM per ton (3.9 l/m per kW) for most water-loop heat pump applications. To ensure proper maintenance and servicing, P/T ports are imperative for temperature, flow verification, and performance checks.

Water-loop heat pump (cooling tower/boiler) systems typically utilize a common loop, maintained between 60 - 90°F (16 - 32°C). The use of a closed circuit evaporative cooling tower with a secondary heat exchanger between the tower and the water loop is recommended. If an open type cooling tower is used continuously, chemical treatment and filtering will be necessary.

Figure 8: Typical Water-Loop Application

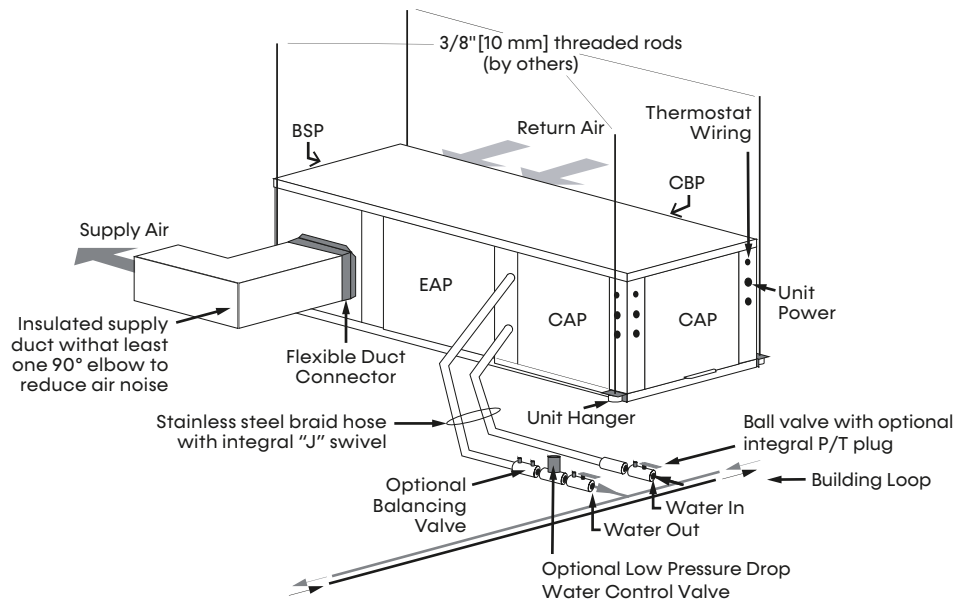

Ground-Loop Heat Pump Application

CAUTION

The following instructions represent industry accepted installation practices for closed loop earth coupled heat pump systems. Instructions are provided to assist the contractor in installing trouble free ground loops. These instructions are recommendations only. State/provincial and local codes MUST be followed and installation MUST conform to ALL applicable codes. It is the responsibility of the installing contractor to determine and comply with ALL applicable codes and regulations.

CAUTION

Ground loop applications require extended range equipment and additional refrigerant/water circuit insulation.

Test individual horizontal loop circuits before backfilling. Test vertical U-bends and pond loop assemblies prior to installation. Pressures of at least 100 psi (689 kPa) should be used when testing. Do not exceed the pipe pressure rating. Test entire system when all loops are assembled.

PRE-INSTALLATION

Prior to installation, locate and mark all existing underground utilities, piping, etc. Install loops for new construction before sidewalks, patios, driveways, and other construction has begun. During construction, accurately mark all ground loop piping on the plot plan as an aid in avoiding potential future damage to the installation.

PIPING INSTALLATION

All ground loop piping materials should be limited to polyethylene fusion only for in-ground sections of the loop. Galvanized or steel fittings should not be used at any time due to their tendency to corrode. All plastic to metal threaded fittings should be avoided due to their potential to leak in ground coupled applications. A flanged fitting should be substituted. P/T plugs should be used so that flow can be measured using the pressure drop of the unit heat exchanger.

Ground loop temperatures can range between 25 and 110°F (-4 to 43°C). Flow rates between 2.25 and 3 GPM (2.41 to 3.23 l/m per kW) of cooling capacity is recommended in these applications.

FLUSHING THE GROUND LOOP

Upon completion of system installation and testing, flush the system to remove all foreign objects and purge to remove all air.

ANTIFREEZE

In areas where minimum entering loop temperatures drop below 40°F (5°C) or where piping will be routed through areas subject to freezing, antifreeze is required. Alcohols and glycols are commonly used as antifreeze; however your local sales office should be consulted to determine the antifreeze best suited to your area. Freeze protection should be maintained to 15°F (9°C) below the lowest expected entering loop temperature. For example, if 30°F (-1°C) is the minimum expected entering loop temperature, the leaving loop temperature would be 22 to 25°F (-6 to -4°C) and freeze protection should be at 15°F (-10°C).

Calculation is as follows:

$$30^{\circ}\text{F} - 15^{\circ}\text{F} = 15^{\circ}\text{F} \quad [-1^{\circ}\text{C} - 9^{\circ}\text{C} = -10^{\circ}\text{C}]$$

All alcohols should be premixed and pumped from a reservoir outside of the building when possible or introduced under the water level to prevent fumes. Calculate the total volume of fluid in the piping system. Then use the percentage by volume shown in the table below for the amount of antifreeze needed. Antifreeze concentration should be checked from a well mixed sample using a hydrometer or refractometer to measure specific gravity.

Table 3: Antifreeze Percentages by Volume

Type	Minimum Antifreeze Concentration % for Low Temperature Protection			
	10°F [-12.2°C]	15°F [-9.4°C]	20°F [-6.7°C]	25°F [-3.9°C]
Methanol	25%	21%	16%	10%
100% USP food grade Propylene Glycol	38%	25%	22%	15%
Ethanol*	29%	25%	20%	14%

* Must not be denatured with any petroleum based product

Models:
SB
072-300

Water Quality Requirements

Table 4: Water Quality Requirements

Clean water is essential to the performance and life span of water source heat pumps. Contaminants, chemicals, and minerals all have the potential to cause damage to the water heat exchanger if not treated properly. All closed-loop water systems should undergo water quality testing and be maintained to the water quality standards listed in this table. All open-loop water systems shall be tested upon installation and periodically to ensure water quality standard in the table below are met.

Water Quality Requirements For Closed-Loop and Open-Loop Systems							
	Description	Symbol	Units	Heat Exchanger Type			
				Closed Loop Recirculating		Open Loop, Tower, Ground Source Well	
				All Heat Exchanger Types	Coaxial HX Copper Tube in Tube	Coaxial HX Cupronickel	Brazed- Plate HX 316 SS
Scaling Potential	pH - Chilled Water <85°F			7.0 to 9.0	7.0 to 9.0	7.0 to 9.0	7.0 to 9.0
	pH - Chilled Water >85°F			8.0 to 10.0	8.0 to 10.0	8.0 to 10.0	8.0 to 10.0
	Alkalinity	(HCO ₃ ⁻)	ppm - CaCO ₃ equivalent	50 to 500	50 to 500	50 to 500	50 to 500
	Calcium	(Ca)	ppm	<100	<100	<100	<100
	Magnesium	(Mg)	ppm	<100	<100	<100	<100
	Total Hardness	(CaCO ₃)	ppm - CaCO ₃ equivalent	30 to 150	150 to 450	150 to 450	150 to 450
	Langelier Saturation Index	LSI		-0.5 to +0.5	-0.5 to +0.5	-0.5 to +0.5	-0.5 to +0.5
	Ryznar Stability Index	RSI		6.5 to 8.0	6.5 to 8.0	6.5 to 8.0	6.5 to 8.0
Corrosion Prevention	Total Dissolved Solids	(TDS)	ppm - CaCO ₃ equivalent	<1000	<1000	<1000	<1000
	Sulfate	(SO ₄ ²⁻)	ppm	<200	<200	<200	<200
	Nitrate	(NO ₃ ⁻)	ppm	<100	<100	<100	<100
	Chlorine (free)	(Cl)	ppm	<0.5	<0.5	<0.5	<0.5
	Chloride (water < 80°F)	(Cl ⁻)	ppm	<20	<20	<150	<150
	Chloride (water > 120°F)	(Cl ⁻)	ppm	<20	<20	<125	<125
	Hydrogen Sulfide ^a	(H ₂ S)	ppb	<0.5	<0.5	<0.5	<0.5
	Carbon Dioxide	(CO ₂)	ppm	0	<50	10 to 50	10 to 50
	Iron Oxide	(Fe)	ppm	<1.0	<1.0	<1.0	<0.2
	Manganese	(Mn)	ppm	<0.4	<0.4	<0.4	<0.4
	Ammonia	(NH ₃)	ppm	<0.05	<0.1	<0.1	<0.1
	Chloramine	(NH ₂ CL)	ppm	0	0	0	0
Fouling & Biological	Iron bacteria		cells/mL	0	0	0	0
	Slime-forming bacteria		cells/mL	0	0	0	0
	Sulfate-reducing bacteria		cells/mL	0	0	0	0
	Suspended Solids ^b	(TSS)	ppm	<10	<10	<10	<10
Electrolysis All HX types	Earth Ground Resistance ^x		Ohms		Consult NEC and local electrical codes for grounding requirements		
	Electrolysis Voltage ^d		mV		Measure voltage and internal water loop to HP ground		
	Leakage Current ^e		mA		Measure current in water loop pipe		
	Building Primary Electrical Ground to unit, must meet local diameter and penetration length requirements. Do not connect heat pump to steel pipe unless dissimilar materials are separated by using DI-electric unions. Galvanic corrosion of heat pump water pipe will occur						

Water Quality Requirements

1. The Water Quality table provides water quality requirements for coaxial and brazed-plate heat exchangers.
2. The water must be evaluated by an independent testing facility comparing site samples against this table. When water properties are outside of these parameters, the water must either be treated by a professional water treatment specialist to bring the water quality within the boundaries of this specification, or an external secondary heat exchanger must be used to isolate the heat pump water system from the unsuitable water. Failure to do so will void the warranty of the heat pump system and will limit liability for damage caused by leaks or system failure.
3. Regular sampling, testing and treatment of the water is necessary to assure that the water quality remains within acceptable levels thereby allowing the heat pump to operate at optimum levels.
4. If closed-loop systems are turned off for extended periods, water samples must be tested prior to operating the system.
5. For optimal performance, it is recommended that the closed-loop piping systems are initially filled with de-ionized water.
6. Well water with chemistry outside of these boundaries, and salt water or brackish water requires an external secondary heat exchanger. Surface/Pond water should not be used.
7. If water temperature is expected to fall below 40°F (4.4°C), antifreeze is required. Refer to the heat pump IOM for the correct solution ratios to prevent freezing.
 - α Hydrogen Sulfide has an odor of rotten eggs. If one detects this smell, a test for H₂S must be performed. If H₂S is detected above the limit indicated, remediation is necessary. Consult with your water testing/treatment professional. If a secondary heat exchanger is required, use appropriate materials as recommended by the heat exchanger supplier.
 - β Suspended solids and particulates must be filtered to prevent fouling and failure of heat exchangers. Strainers or particulate filters must be installed to provide a maximum particle size of 600 micron (0.60 mm, 0.023 inch) using a 20 to 30 mesh screen size. When a loop is installed in areas with fine material such as sand or clay, further filtration is required to a maximum of 100 micron. Refer to the Strainer / Filter Sizing Chart to capture the particle sizes encountered on the site.
 - χ The WSHP piping system or other plumbing pipes must not be used as the building ground. An electrical grounding system using a dedicated ground rod meeting NEC and local electrical codes must be installed.
 - δ Refer to the Antifreeze Percentages by Volume table for instructions on measuring resistance and leakage currents within water loops.

Strainer / Filter Sizing

Mesh Size	Particle Size		
	Microns	MM	Inch
20	840	0.840	0.0340
30	533	0.533	0.0210
60	250	0.250	0.0100
100	149	0.149	0.0060
150	100	0.100	0.0040
200	74	0.074	0.0029

ppm = parts per million
ppb = parts per billion

Models:
SB
072-300

Water Quality Requirements

Measuring Earth Ground Resistance for Ground-Water Applications

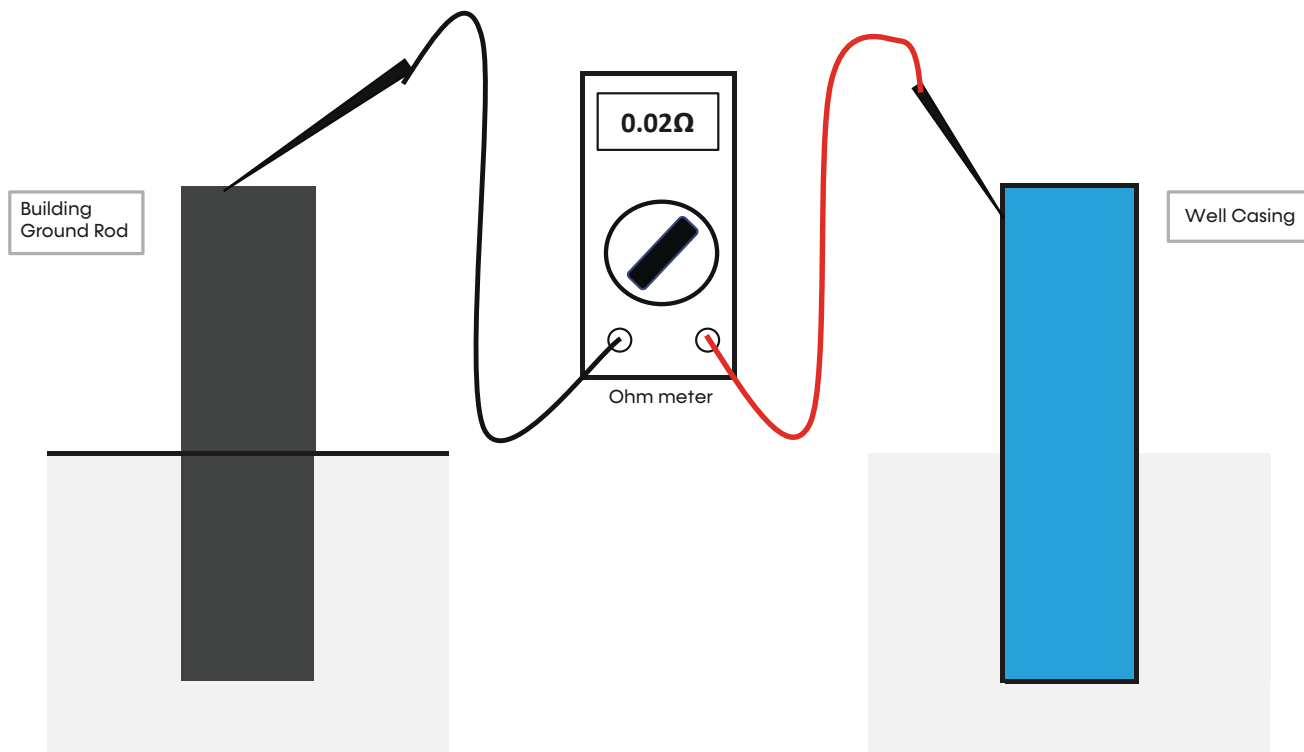

Measure the earth ground bond using an Ohm meter between the building's ground rod and the steel well casing.

The resistance measured should be zero Ohms. The NEC allows a resistance to ground up to 20 Ohms. Any resistance above zero indicates a poor earth ground, which may be the result of a hot neutral line or that conductive water is present. Both of these may lead to electrolysis and corrosion of the heat pump piping. A check for both should be performed and resolved.

NOTE: If the well casing is plastic, a conductive path can be achieved by inserting a #6 AWG bare copper wire into the well water. Remove the temporary conductor when finished.

Water Quality Requirements

Models:
SB
072-300

Measuring Electrolysis, Voltage, and Current for Ground-Water Applications

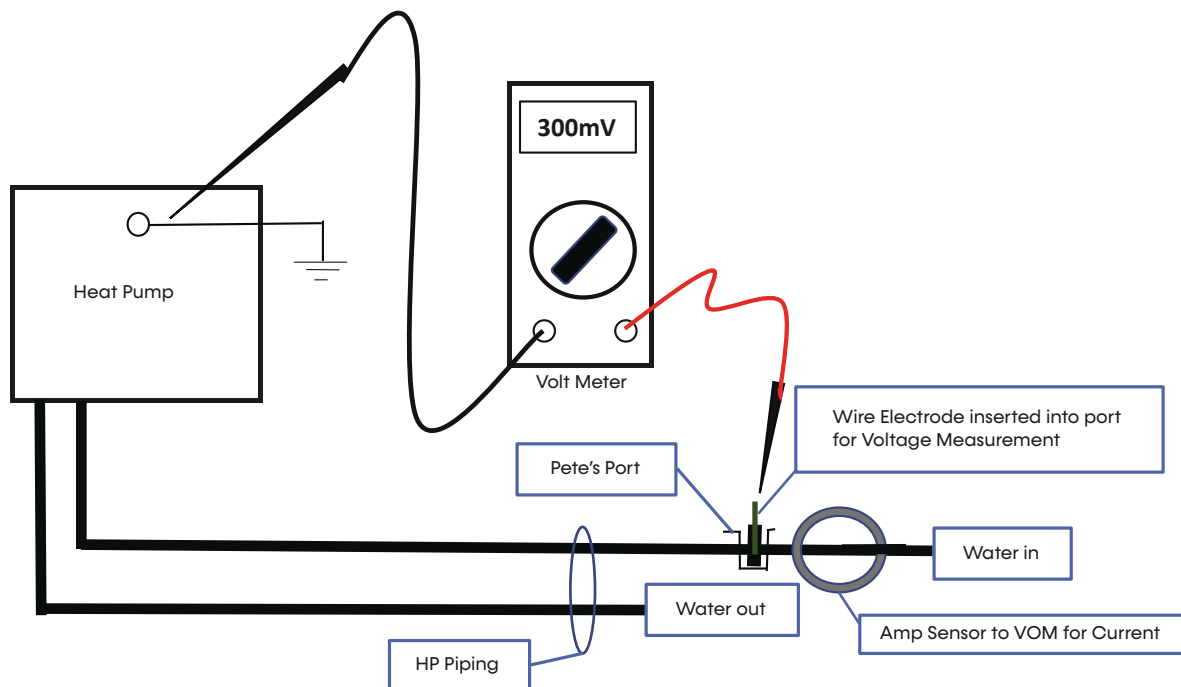

Measure the electrolysis voltage using a volt meter between the heat pump ground and a #14 AWG solid copper wire electrode inserted into the water using a Pete's style access port.

The heat pump must be operating and the water stream flowing.

The voltage measured should be less than 300mV (0.300V). If the voltage is higher than 500mV, electrolysis will occur and corrosion will result.

If voltage is measured, the cause is a high-resistance earth ground or current on the neutral conductor. Remedial measures should be performed.

Measure the current flowing through the piping system by using an amp clamp probe on the water-in line. The heat pump must be operating and the water stream flowing.

There should be zero amps measured. If current is present, there is leakage current to the plumbing system and it must be rectified to prevent pipe corrosion.

TRANQUILITY® (SB) COMPACT HIGH-CAPACITY SERIES– IOM

Models:
SB
072-300

Electrical Data: Standard

Model	Voltage Code	Voltage	Min/Max Voltage	Blower Option	Compressor			Fan Motor FLA	Rated Current Amps	Min Circuit Amps	SCCR kA RMS Symmetrical	SCCR Volts Maximum	Max Fuse HACR Amps
					Qty	RLA	LRA						
SB072	K	208/230-3-60	187/253	1,2,3	2	12.2	97.5	3.0	27.4	30.5	5	600	40
				4,5	2	12.2	97.5	5.8	30.2	33.3	5	600	45
				6	2	12.2	97.5	5.2	29.6	32.6	5	600	40
	L	460-3-60	414/506	1,2,3	2	5.8	44.3	1.4	13.0	14.5	5	600	20
				4,5	2	5.8	44.3	2.9	14.5	16.0	5	600	20
				6	2	5.8	44.3	6.9	18.5	20.2	5	600	25
	M	575-3-60	518/633	1,2,3	2	4.5	27.1	1.2	10.2	11.3	5	600	15
				4,5	2	4.5	27.1	2.2	11.2	12.3	5	600	15
	SB096	K	208/230-3-60	187/253	1,2,3	2	12.8	120.4	5.8	31.4	34.6	5	600
4,5					2	12.8	120.4	8.2	33.8	37.0	5	600	45
6					2	12.8	120.4	9.3	34.9	38.1	5	600	50
L		460-3-60	414/506	1,2,3	2	6.0	49.4	2.9	14.9	16.4	5	600	20
				4,5	2	6.0	49.4	4.1	16.1	17.6	5	600	20
				6	2	6.0	49.4	9.6	21.6	24.0	5	600	30
M		575-3-60	518/633	1,2,3	2	5.8	41.0	2.2	13.8	15.3	5	600	20
				4,5	2	5.8	41.0	3.2	14.8	16.3	5	600	20
SB120		K	208/230-3-60	187/253	1,2,3	2	18.6	155.0	8.2	45.4	50.1	5	600
	4,5				2	18.6	155.0	14.0	51.2	55.9	5	600	70
	6				2	18.6	155.0	11.0	48.2	52.8	5	600	70
	L	460-3-60	414/506	1,2,3	2	8.3	58.1	4.1	20.7	22.8	5	600	30
				4,5	2	8.3	58.1	6.5	23.1	25.2	5	600	30
				6	2	8.3	58.1	13.6	30.2	33.6	5	600	45
	M	575-3-60	518/633	1,2,3	2	7.7	47.8	3.2	18.6	20.5	5	600	25
				4,5	2	7.7	47.8	5.2	20.6	22.5	5	600	30
	SB168	K	208/230-3-60	187/253	1,2,3	2	24.4	200.0	8.2	57.0	63.1	5	600
4,5					2	24.4	200.0	14.0	62.8	68.9	5	600	90
6					2	24.4	200.0	8.9	57.7	63.8	5	600	80
L		460-3-60	414/506	1,2,3	2	11.9	103.0	4.1	27.9	30.9	5	600	40
				4,5	2	11.9	103.0	6.5	30.3	33.3	5	600	45
				6	2	11.9	103.0	13.6	37.4	40.8	5	600	50
M		575-3-60	518/633	1,2,3	2	9.4	78.0	3.2	22.0	24.4	5	600	30
				4,5	2	9.4	78.0	5.2	24.0	26.4	5	600	35
SB192		K	208/230-3-60	187/253	1,2,3	2	27.7	178.5	8.2	63.6	70.5	5	600
	4,5				2	27.7	178.5	14.0	69.4	76.3	5	600	100
	6				2	27.7	178.5	14.6	70.0	76.9	5	600	100
	L	460-3-60	414/506	1,2,3	2	11.5	103.0	4.1	27.1	30.0	5	600	40
				4,5	2	11.5	103.0	6.5	29.5	32.4	5	600	40
				6	2	11.5	103.0	13.6	36.6	40.0	5	600	50
	M	575-3-60	518/633	1,2,3	2	9.0	78.0	3.2	21.2	23.5	5	600	30
				4,5	2	9.0	78.0	5.2	23.2	25.5	5	600	30
	SB240	K	208/230-3-60	187/253	1,2,3	2	28.5	255.0	14.0	71.0	78.1	5	600
6					2	28.5	255.0	28.0	85.0	92.1	5	600	110
L		460-3-60	414/506	1,2,3	2	13.5	123.0	6.5	33.5	36.9	5	600	50
				6	2	13.5	123.0	18.8	45.8	50.5	5	600	60
M		575-3-60	518/633	1,2,3	2	10.7	93.7	5.2	26.6	29.3	5	600	35
SB300	K	208/230-3-60	187/253	6	2	40.8	270.0	22.3	103.9	114.1	5	600	150
	L	460-3-60	414/506	6	2	19.4	147.0	22.1	60.9	66.4	5	600	80

Electrical Data: Dual Point Power

Model	Voltage Code	Voltage	Min/Max Voltage	Blower Option	Compressor Power Supply							Fan Power Supply					
					Qty	RLA	LRA	Rated Current Amps	Min Circuit Amps	SCCR kA RMS Symmetrical	SCCR Volts Max	Max Fuse HACR Amps	Fan Motor FLA	Min Circuit Amps	SCCR kA RMS Symmetrical	SCCR Volts Max	Max Fuse HACR Amps
SB072	K	208/230-3-60	187/253	A,B,C	2	12.2	97.5	24.4	27.5	5	600	35	3.0	3.8	5	600	15
				D,E	2	12.2	97.5	24.4	27.5	5	600	35	5.8	7.3	5	600	15
				F	2	12.2	97.5	24.4	27.5	5	600	35	5.2	6.4	5	600	15
	L	460-3-60	414/506	A,B,C	2	5.8	44.3	11.6	13.1	5	600	15	1.4	1.8	5	600	15
				D,E	2	5.8	44.3	11.6	13.1	5	600	15	2.9	3.6	5	600	15
				F	2	5.8	44.3	11.6	13.1	5	600	15	6.9	8.6	5	600	15
	M	575-3-60	518/633	A,B,C	2	4.5	27.1	9.0	10.1	5	600	15	1.2	1.5	5	600	15
				D,E	2	4.5	27.1	9.0	10.1	5	600	15	2.2	2.8	5	600	15
	SB096	K	208/230-3-60	187/253	A,B,C	2	12.8	120.4	25.6	28.8	5	600	40	5.8	7.3	5	600
D,E					2	12.8	120.4	25.6	28.8	5	600	40	8.2	10.3	5	600	15
F					2	12.8	120.4	25.6	28.8	5	600	40	9.3	11.6	5	600	20
L		460-3-60	414/506	A,B,C	2	6.0	49.4	12.0	13.5	5	600	15	2.9	3.6	5	600	15
				D,E	2	6.0	49.4	12.0	13.5	5	600	15	4.1	5.1	5	600	15
				F	2	6.0	49.4	12.0	13.5	5	600	15	9.6	12.0	5	600	20
M		575-3-60	518/633	A,B,C	2	5.8	41	11.6	13.1	5	600	15	2.2	2.8	5	600	15
				D,E	2	5.8	41	11.6	13.1	5	600	15	3.2	4.0	5	600	15
SB120		K	208/230-3-60	187/253	A,B,C	2	18.6	155	37.2	41.9	5	600	60	8.2	10.3	5	600
	D,E				2	18.6	155	37.2	41.9	5	600	60	14.0	17.5	5	600	30
	F				2	18.6	155	37.2	41.9	5	600	60	11.0	13.7	5	600	20
	L	460-3-60	414/506	A,B,C	2	8.3	58.1	16.6	18.7	5	600	25	4.1	5.1	5	600	15
				D,E	2	8.3	58.1	16.6	18.7	5	600	25	6.5	8.1	5	600	15
				F	2	8.3	58.1	16.6	18.7	5	600	25	13.6	17.0	5	600	30
	M	575-3-60	518/633	A,B,C	2	7.7	47.8	15.4	17.3	5	600	25	3.2	4.0	5	600	15
				D,E	2	7.7	47.8	15.4	17.3	5	600	25	5.2	6.5	5	600	15

Table continued on next page.

Models:
SB
072-300

Electrical Data: Dual Point Power

Table continued from previous page.

Model	Voltage Code	Voltage	Min/Max Voltage	Blower Option	Compressor Power Supply							Fan Power Supply					
					Qty	RLA	LRA	Rated Current Amps	Min Circuit Amps	SCCR kA RMS Symmetrical	SCCR Volts Max	Max Fuse HACR Amps	Fan Motor FLA	Min Circuit Amps	SCCR kA RMS Symmetrical	SCCR Volts Max	Max Fuse HACR Amps
SB168	K	208/230-3-60	187/253	A,B,C	2	24.4	200	48.8	54.9	5	600	70	8.2	10.3	5	600	15
				D,E	2	24.4	200	48.8	54.9	5	600	70	14.0	17.5	5	600	30
				F	2	24.4	200	48.8	54.9	5	600	70	8.9	11.1	5	600	15
	L	460-3-60	414/506	A,B,C	2	11.9	103	23.8	26.8	5	600	35	4.1	5.1	5	600	15
				D,E	2	11.9	103	23.8	26.8	5	600	35	6.5	8.1	5	600	15
				F	2	11.9	103	23.8	26.8	5	600	35	13.6	17.0	5	600	30
	M	575-3-60	518/633	A,B,C	2	9.4	78	18.8	21.2	5	600	30	3.2	4.0	5	600	15
				D,E	2	9.4	78	18.8	21.2	5	600	30	5.2	6.5	5	600	15
	SB192	K	208/230-3-60	187/253	A,B,C	2	27.7	178.5	55.4	62.3	5	600	90	8.2	10.3	5	600
D,E					2	27.7	178.5	55.4	62.3	5	600	90	14.0	17.5	5	600	30
F					2	27.7	178.5	55.4	62.3	5	600	90	14.6	18.3	5	600	30
L		460-3-60	414/506	A,B,C	2	11.5	103	23.0	25.9	5	600	35	4.1	5.1	5	600	15
				D,E	2	11.5	103	23.0	25.9	5	600	35	6.5	8.1	5	600	15
				F	2	11.5	103	23.0	25.9	5	600	35	13.6	17.0	5	600	30
M		575-3-60	518/633	A,B,C	2	9.0	78	18.0	20.3	5	600	25	3.2	4.0	5	600	15
				D,E	2	9.0	78	18.0	20.3	5	600	25	5.2	6.5	5	600	15
SB240		K	208/230-3-60	187/253	A,B,C	2	28.5	255	57.0	64.1	5	600	90	14.0	17.5	5	600
	F				2	28.5	255	57.0	64.1	5	600	90	28.0	35.0	5	600	60
	L	460-3-60	414/506	A,B,C	2	13.5	123	27.0	30.4	5	600	40	6.5	8.1	5	600	15
				F	2	13.5	123	27.0	30.4	5	600	40	18.8	23.5	5	600	40
	M	575-3-60	518/633	A,B,C	2	10.7	93.7	21.4	24.1	5	600	30	5.2	6.5	5	600	15
SB300	K	208/230-3-60	187/253	F	2	40.8	270	81.6	91.8	5	600	125	22.3	27.9	5	600	50
	L	460-3-60	414/506	F	2	19.4	147	38.8	43.7	5	600	60	22.1	27.6	5	600	45

Electrical: Power and Low Voltage Wiring

ELECTRICAL

Line Voltage - All field installed wiring, including electrical ground, must comply with NFPA 70: National Electrical Code (NEC), CSA C22.1: Canadian Electrical Code (CE Code), as well as applicable local codes. Refer to the unit electrical data for fuse sizes. Consult wiring diagram for field connections that must be made by the installing (or electrical) contractor. All final electrical connections must be made with a length of flexible conduit to minimize vibration and sound transmission to the building.

GENERAL LINE-VOLTAGE WIRING

Be sure the available power is the same voltage and phase shown on the unit serial plate. Line- and low-voltage wiring must be done in accordance with local codes or the National Electric Code, whichever is applicable.

TRANSFORMER

All 208/230V units are factory wired for 208V. If supply voltage is 230V, installer must rewire transformer. See wire diagram for connections.

DISCONNECT

Units with a factory-installed disconnect switch will provide full separation of all poles and disconnection from main line voltage. For units where factory disconnect is not selected as an option, the installer must incorporate the means to fully disconnect the line voltage in the fixed wiring in accordance with wiring rules and local electrical codes.

LOW WATER-TEMPERATURE CUTOUT SELECTION

The CXM2 allows the field selection of low-water (or water-antifreeze solution) temperature limit by clipping jumper JW3, which changes the sensing temperature associated with thermistor LT1. Note that the LT1 thermistor is located on the refrigerant line between the coaxial heat exchanger and expansion device (TXV or cap tube). Therefore, LT1 is sensing refrigerant temperature, not water temperature, which is a better indication of how water flow rate/temperature is affecting the refrigeration circuit.

Figure 9: LT1 Limit Setting

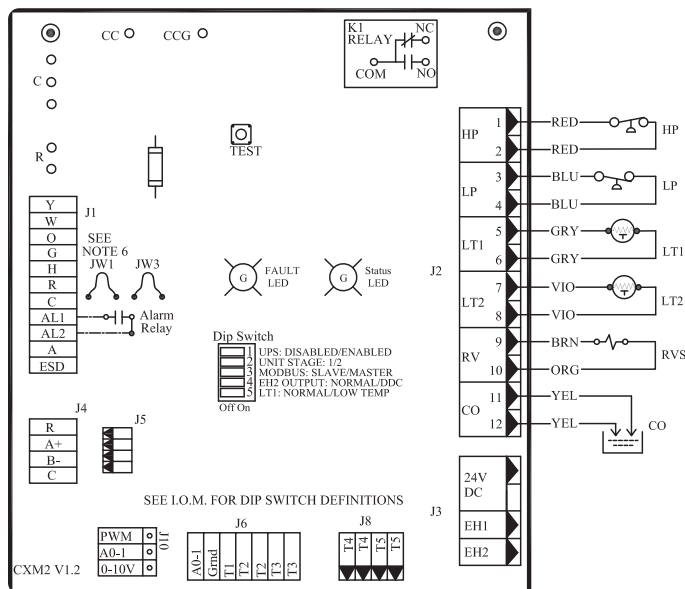

The factory setting for LT1 is for systems using water (30°F [-1.1°C] refrigerant temperature). In low water temperature (extended range) applications with antifreeze (most ground loops), jumper JW3 should be clipped as shown in the figure below to change the setting to 10°F (-12.2°C) refrigerant temperature, a more suitable temperature when using an antifreeze solution. All SB units operating with entering water temperatures below 59°F (15°C) must include the optional water/refrigerant circuit insulation package to prevent internal condensation.

Figure 10: SB Horizontal Control Box (Representative)

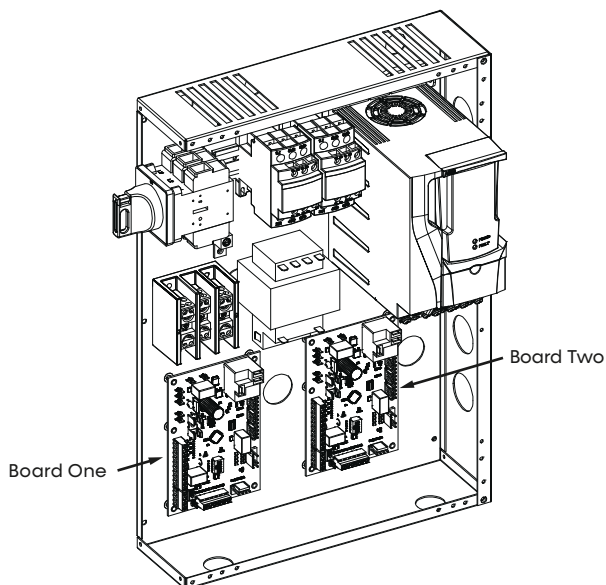

Models:
SB
072-300

Electrical: CXM2 Example Wiring Diagram

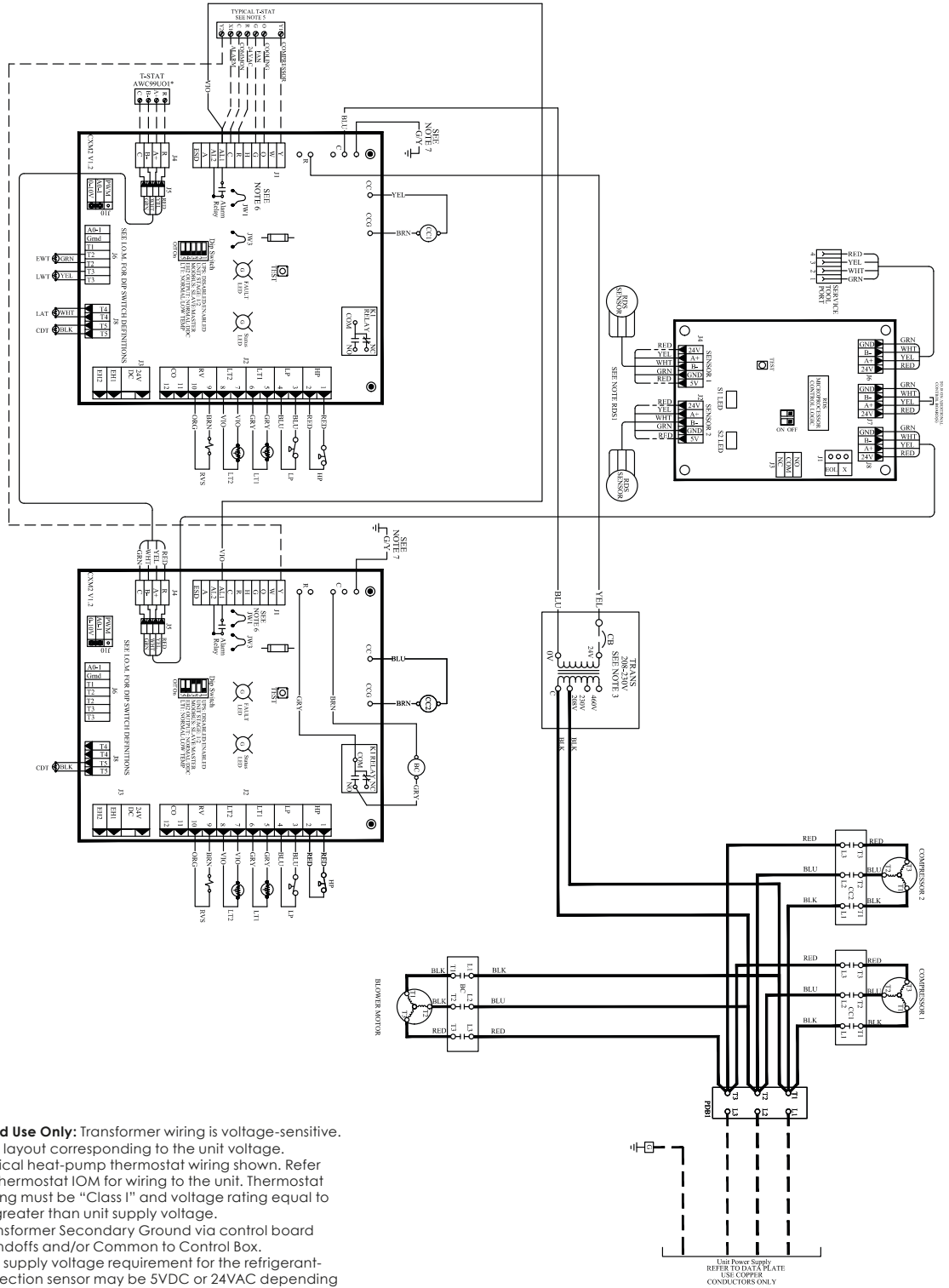

NOTES:

1. **Field Use Only:** Transformer wiring is voltage-sensitive. Use layout corresponding to the unit voltage.
2. Typical heat-pump thermostat wiring shown. Refer to thermostat IOM for wiring to the unit. Thermostat wiring must be "Class 1" and voltage rating equal to or greater than unit supply voltage.
3. Transformer Secondary Ground via control board standoffs and/or Common to Control Box.
4. The supply voltage requirement for the refrigerant-detection sensor may be 5VDC or 24VAC depending on the type of sensor provided by the manufacturer.

Electrical: Low Voltage Wiring

MODELS WITH WATERSIDE ECONOMIZER

Controller is factory assembled. Factory settings are 45°F (7.2°C), valve opens, closes at 55°F (12.8°C), and 5 minute short cycle delay. Settings are adjustable.

ACCESSORY CONNECTIONS

A terminal paralleling the compressor contactor coil has been provided on the CXM2. Terminal “A” is designed to control accessory devices, such as water valves. **NOTE: This terminal should be used only with 24V signals and not line voltage.** Terminal “A” is energized with the compressor contactor. See the specific unit wiring diagram for details.

Table 5: Low Voltage VA Ratings

Component	VA
Typical Blower Relay	6 - 7
Typical Reversing Valve Solenoid	4 - 6
30 A Compressor Contactor	6 - 9
Subtotal	16 - 22
+ CXM2 (5 - 9VA)*	21 - 31
Remaining VA for Accessories	19 - 29

*Standard transformer for SB units is 100VA.

Figure 11: Accessory Wiring

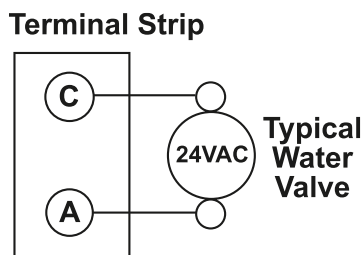

CAUTION

Many units are installed with a factory or field-supplied manual or electric shut-off valve. **DAMAGE WILL OCCUR** if shut-off valve is closed during unit operation. A high-pressure switch must be installed on the heat-pump side of any field provided shut-off valves and connected to the heat-pump controls in series with the built-in refrigerant circuit high-pressure switch to disable compressor operation if water pressure exceeds pressure switch setting. The field-installed high-pressure switch shall have a cut-out pressure of 300 psig and a cut-in pressure of 250 psig. This pressure switch can be ordered from ClimateMaster with a ¼-inch internal flare connection as part number 39B0005N02.

WATER SOLENOID VALVES

An external solenoid valve(s) should be used on ground water installations to shut off flow to the unit when the compressor is not operating. A slow closing valve may be required to help reduce water hammer. Figure 12 shows typical wiring for a 24VAC external solenoid valve. Figure 13 illustrates a slow-closing water control valve wiring for a style of typical accessory water valve. Slow-closing valves take approximately 60 seconds to open (very little water flows before 45 seconds). Once fully open, an end switch allows the compressor to be energized. Only relay or triac based electronic thermostats should be used with slow-closing valves. When wired as shown, the slow-closing valve operate properly with the following notations:

1. The valve will remain open during a unit lockout.
2. The valve will draw approximately 25-35VA through the “Y” signal of the thermostat.

NOTE: This valve can overheat the anticipator of an electromechanical thermostat. Therefore, only relay or triac based thermostats should be used.

Figure 12: Optional Motorized Water Valve Wiring

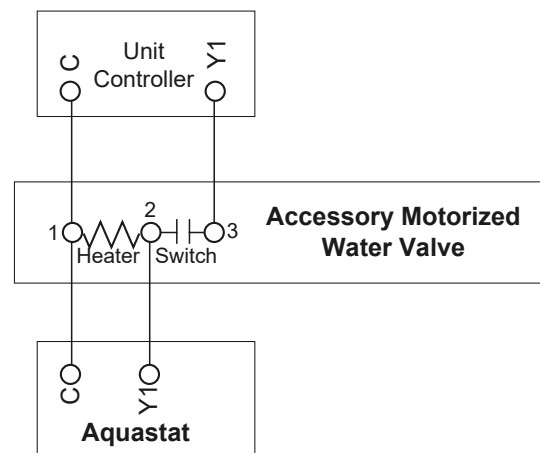

THERMOSTAT CONNECTIONS

The thermostat should be wired directly to the CXM2. See “Electrical: Thermostat Wiring” (Figure 15) for specific terminal connections. Review the appropriate AOM (Application, Operation and Maintenance) manual for units with DDC controls.

Models:
SB
072-300

Electrical: Low Voltage Wiring

REFRIGERANT DETECTION SYSTEM (RDS)

The function, operation, and required servicing measures for the Refrigerant Detection System (RDS) include the following:

- The RDS monitors the status of the refrigerant sensor(s) in the unit. If refrigerant is detected above the maximum threshold, the control enables the unit blower, disables the compressor(s), and enables the pilot relay on the RDS control board. You can use this relay to open external zoning dampers and/or activate external mechanical ventilation. The relay is normally closed (NC) and can control a signal with a maximum of 28VA @ 24VAC.
- A fault is enabled if the RDS control board loses communication with a refrigerant sensor or if the main control board loses communication with the RDS board. See Functional Troubleshooting for steps to troubleshoot the RDS.
- The End of Line (EoL) termination is used to prevent signal reflection issues in the communication network. When the EoL termination is enabled, it places a resistor at the end of the communication line, ensuring proper signal integrity and reducing potential communication errors. Add the EoL termination resistor when the RDS board is the end of a daisy-chain, and the total length of the wire is greater than 50 feet.

Figure 13: RDS Board

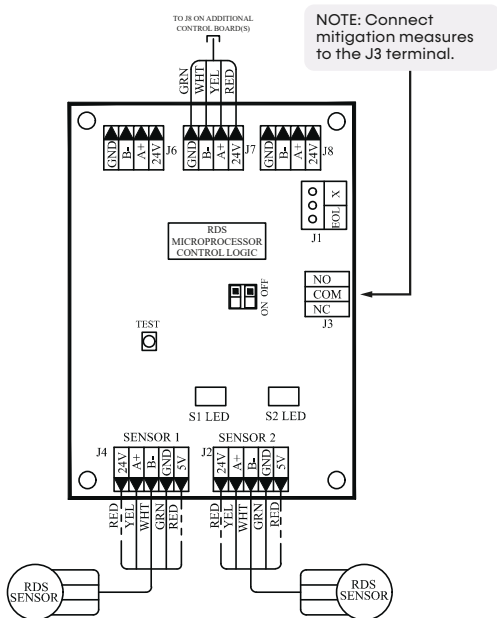

RDS SENSOR PLACEMENT

Use the following guidelines to maintain the installation and placement of the field-installed refrigerant detection sensor upstream of the unit's return-air inlet:

1. The sensor must be located within 3 inches of the unit
2. The sensor must be on the same plane or lower than the unit
3. The sensor must be on the same side of the coil as the feeder tubes (feeder tubes are located near the electrical components)

NOTICE

The sensor cannot be installed in a way that exposes it to water and must be installed using the orientation displayed in the figure below.

Figure 14: Sensor Placement

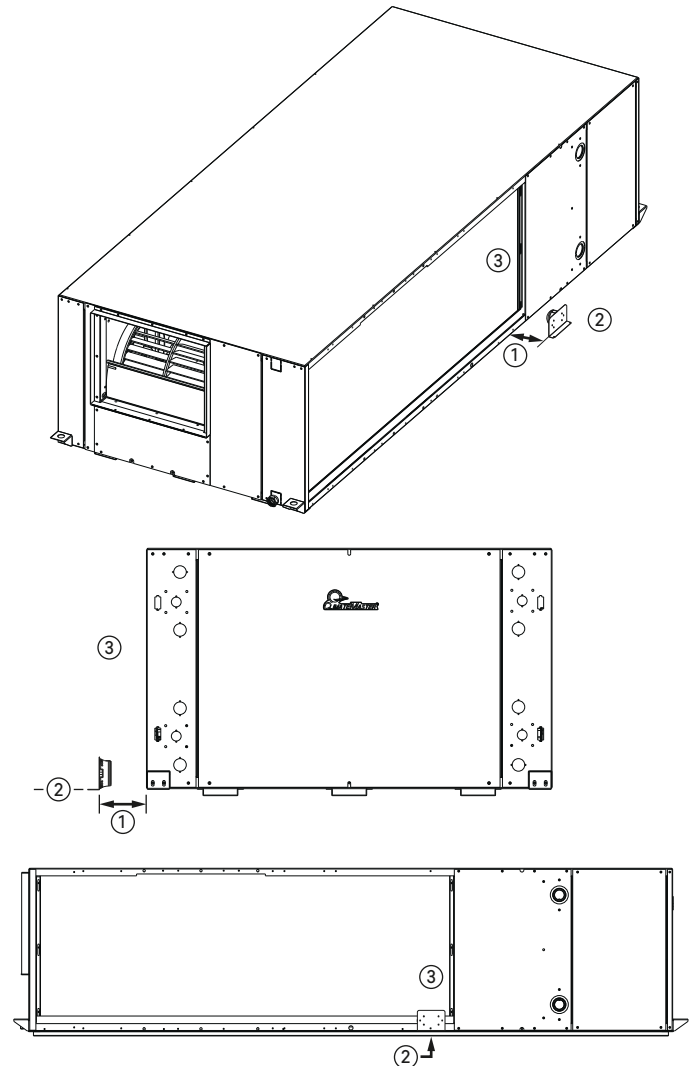

Electrical: Thermostat Wiring

THERMOSTAT INSTALLATION

The thermostat should be located on an interior wall in a larger room, away from supply duct drafts. DO NOT locate the thermostat in areas subject to sunlight, drafts or on external walls. The wire access hole behind the thermostat may in certain cases need to be sealed to prevent erroneous temperature measurement.

Position the thermostat back plate against the wall so that it appears level and so the thermostat wires protrude through the middle of the back plate.

Mark the position of the back plate mounting holes and drill holes with a 3/16-inch (5-mm) bit. Install supplied anchors and secure plate to the wall. Thermostat wire must be 18 AWG wire. Wire the appropriate thermostat as shown in the figure below to the low voltage terminal strip on the CXM2. Practically any heat pump thermostat will work with ClimateMaster units, provided it has the correct number of heating and cooling stages.

Figure 15: Thermostat Connection

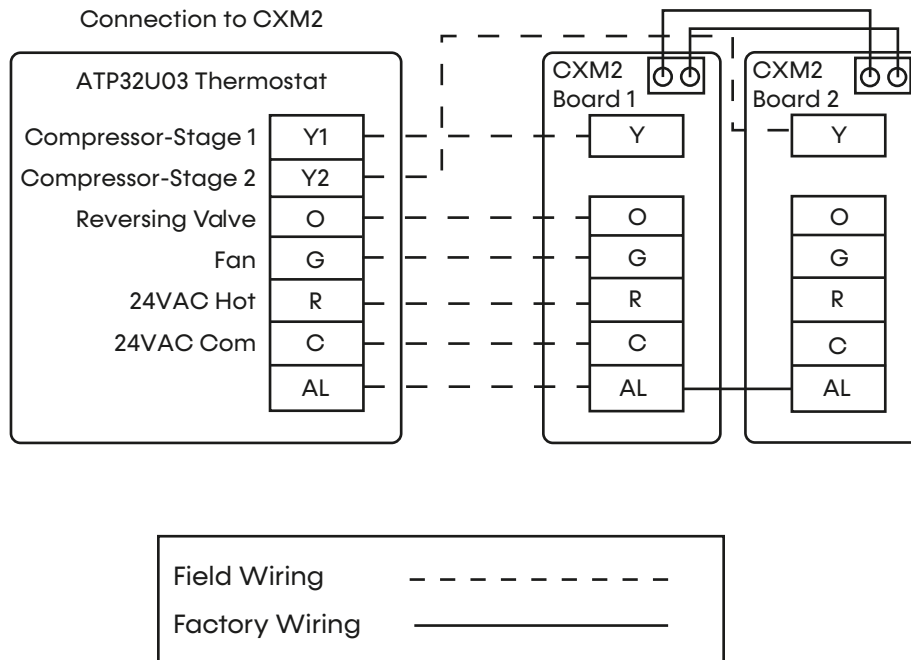

Models:
SB
072-300

Electrical: External Pump Control

Figure 16: External Pump Control Diagram

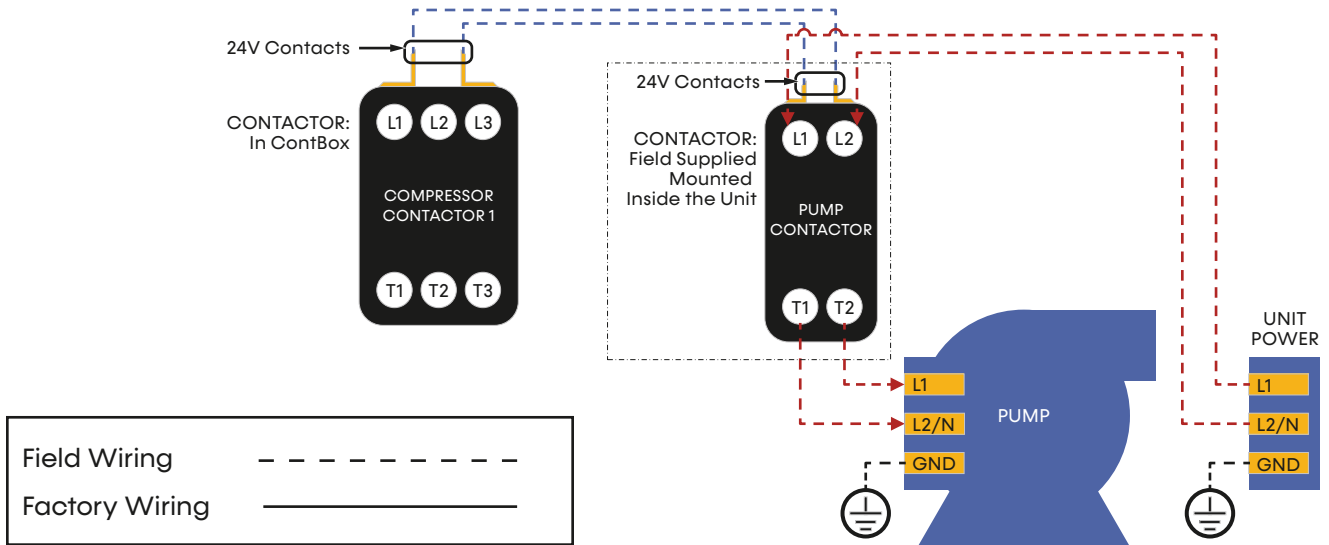
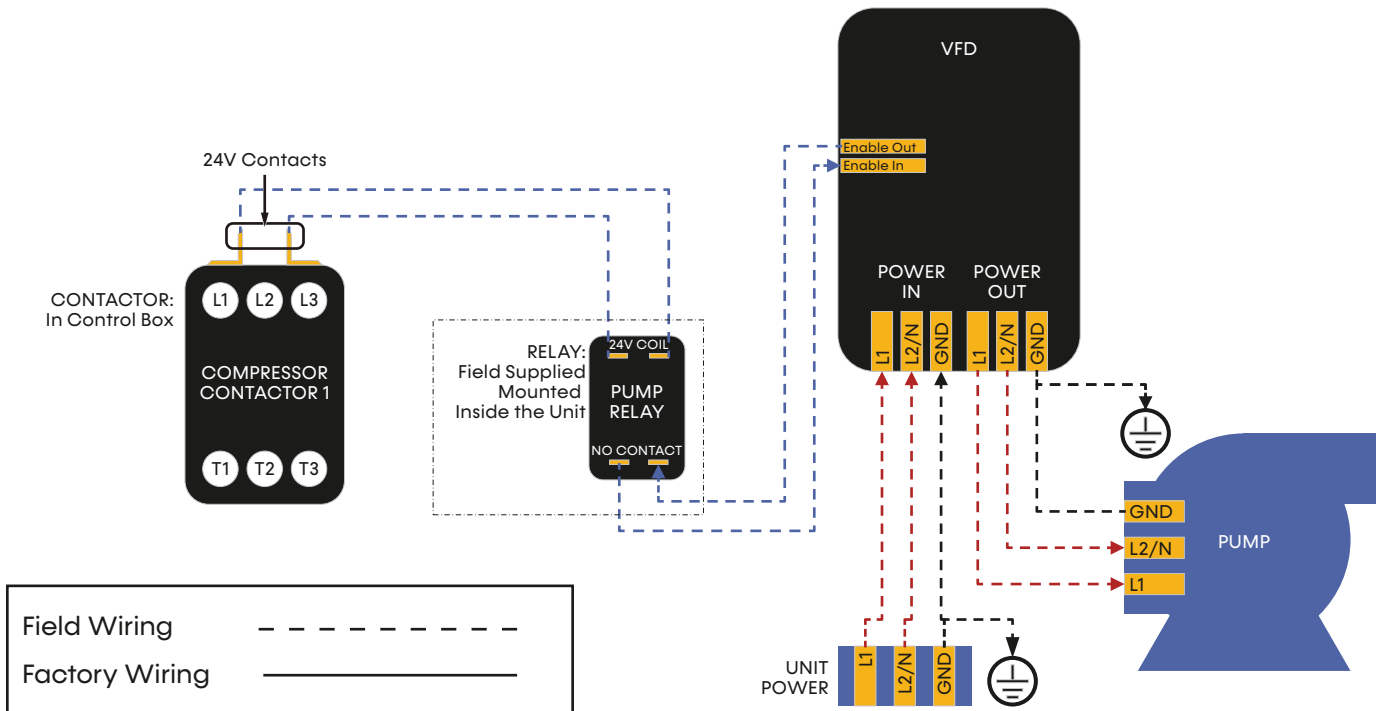

Figure 17: External Pump Control with VFD Diagram



Controls: CXM2 Communicating Controls



CXM2 Communicating Controls

For detailed controller information, see the CXM2 Application, Operation, and Maintenance (AOM) manual (part # 97B0137N01). To confirm the controller type of your particular unit, refer to digit 9 on the unit model number and the unit nomenclature diagram found on page 3 of this manual.

Models:
SB
072-300

Blower Adjustment

CAUTION

Always disconnect all power supply(s) to unit prior to making belt or sheave adjustments. Inadvertently starting of the motor can cause damage to the equipment and personal injury.

AIRFLOW AND EXTERNAL STATIC PRESSURE

Selection Adjustment

The SB Series is available with standard, low, and high static options. These options will substitute a different blower drive sheave for each static range. In addition certain static ranges (see blower tables) may require the optional large fan motor. Please specify static range and motor horsepower when ordering. See model nomenclature.

Sheave Adjustment

The SB Series is supplied with variable sheave drive on the fan motor to adjust for differing airflows at various ESP conditions. Select an airflow requirement on the left side of the table, then move horizontally to right under the required ESP. Contractor is responsible for balancing airflow, and maintaining static in duct as needed. Sheaves can be adjusted through the outlined static range at the selected airflows. Fully closed, the sheave will produce the highest static capability (higher rpm). To adjust sheave position: loosen belt tension and remove belt, loosen set screw on variable sheave (on fan motor) and open sheave to desired position. Re-tighten set screw and replace belt and set belt tension as below.

Sheave and Pulley Alignment

Verify belt is straight; misalignment will cause premature belt failure. Adjust sheave if needed.

Belt Tensioning

An overly loose belt will, upon motor start, produce a slippage 'squeel' and cause premature belt failure and or intermittent airflow. An overly-tight belt can cause premature belt, motor, or blower bearing failure.

Use the following steps to ensure proper belt tensioning:

1. Remove belt from motor sheave
2. Lift motor assembly
3. Loosen the $\frac{5}{16}$ -inch hex nuts on the grommet motor adjustment bolts (two per bolt). To increase the belt tension loosen the top hex nut. To decrease the belt tension loosen the bottom hex nut.
4. Turn the bolts by hand to the desired position then tighten the $\frac{5}{16}$ -inch hex nuts (two per bolt).
5. Lower the motor assembly
6. Install the belt
7. The belt should be tensioned with a tensioning gauge method such as the Browning Belt Tensioner to set proper belt tension (See next page).

NOTES:

- **Motor position should not need adjustment.**
- **Motor sheave position is at mid position of each sheave. Thus the motor sheave is typically 2.5 turns open on a 5-turn sheave.**

Special Note for AHRI Testing

The Units should be adjusted as follows for rated airflow:

- SB072 - 2400cfm/2.5 turns and 0.57 in wg ESP
- SB096 - 3200cfm/3.0 turns and 0.62 in wg ESP
- SB120 - 4000cfm/3.0 turns and 0.59 in wg ESP

VFD Operation

Models:
SB
072-300

SINGLE ZONE VARIABLE AIR VOLUME (VAV)

Products with option “6” or “F” in the 14th digit of the model number come with a variable frequency drive (VFD) and are intended to be applied in single zone VAV applications. SB units use two CXM2 in a dual-board configuration. The VFD is controlled by board 2. The VFD receives a modulating 0-10 VDC signal from the CXM2, and varies the output frequency directly proportionally to the input signal. With 60 Hz frequency, a signal of 10 VDC will result in a 60 Hz frequency to the motor and 100% fan speed. If the signal is 5 VDC, the VFD output will be 30 Hz (50% fan speed).

VFD BLOWER OPERATION

If the CXM2 is configured for VFD blower operation, the CXM2 will control an external VFD using a 0–10 VDC control signal on AO1, and will default to the LAT control mode.

NOTE: VFD output is 50% of last value during heating or cooling blower off delay times.

The actual operating range for the VFD when the blower should be active will be 2–10 VDC associated to the operating speed of 0–100%. When the VFD should be off, the output should be set to 0 VDC.

For each unit size, there will be a maximum and minimum operating speed that the VFD can be operated at for any mode, defined in Table 6.

The VFD blower may be operated in discrete speed or LAT control modes. If configured for discrete speed operation, the VFD speed will be operated using one of the three set operating speeds for each unit size, defined Table 6. If configured for LAT operation, the VFD speed will be controlled by the CXM2 to achieve or maintain the selected target LAT value for the current operating mode.

DISCRETE SPEED VFD OPERATION

When the CXM2 is configured for discrete-speed VFD operation, the VFD speed will be set to the selected operating speed (A, B or C) for full-load heating or cooling. Full-load operation is defined as the second stage enabled in either heating or cooling. The possible discrete operating speeds for each unit size are defined in Table 6.

When the CXM2 is configured for discrete-speed VFD operation, the VFD operating speed may be increased or decreased by 10%. The speed offset option defaults to normal (no offset). To increase the VFD operating speed by 10%, set the speed offset option to Increase. To decrease the VFD operating speed by 10%, set the speed offset option decrease.

When operating in first-stage heating or cooling, the VFD speed will be set to the percentage multiplier of the selected full-load operating speed (A, B or C, plus or minus adjustment) listed for each unit size as defined in Table 6.

LAT CONTROL VFD OPERATION

When the CXM2 is configured for LAT control operation, the VFD speed will be controlled by the CXM2 to maintain the selected target LAT for heating or cooling operation.

When a compressor demand is recognized, the VFD output will be set to the most recent operating speed of the VFD in the current operating mode (heating or cooling). If there is no value stored from a previous heating or cooling cycle, the VFD speed will initially be set to 75% or 8.0 VDC. After the VFD speed is initially set, the VFD control signal will not be adjusted until after 90 seconds of compressor operation, and then will be periodically checked and adjusted every 10 seconds if needed to maintain the LAT.

Models:
SB
072-300

VFD Operation

If the control switches from the heating mode to cooling, or cooling to heating without de-activating the compressor, the VFD control voltage will immediately switch to the last stored control voltage for the new operating mode, and then will not be adjusted for the first 90 seconds of operation in the new operating mode.

The VFD control voltage is increased or decreased incrementally based on the magnitude of the differential between the current LAT and the target LAT, using the following:

LAT differential Actual – Target	VFD adjust (VDC)
$\Delta T \leq 1.0^{\circ}\text{F}$	0.0
$1.0 < \Delta T \leq 2.0^{\circ}\text{F}$	0.1
$2.0 < \Delta T \leq 3.0^{\circ}\text{F}$	0.2
$3.0 < \Delta T \leq 5.0^{\circ}\text{F}$	0.3
$\Delta T > 5.0^{\circ}\text{F}$	0.4

The VFD control voltage is increased or decreased based on both the operating mode and the whether the current LAT is above or below the target LAT, using the following:

Operating mode	LAT differential (Actual – Target)	VFD voltage adjustment
Heat	Above	Increase
	Below	Decrease
Cool	Above	Decrease
	Below	Increase

NOTE: Blower speed is directly proportional to VFD output frequency and voltage

When the control stages from first to second stage operation, the output voltage signal will be immediately increased by 25% of the current value, not to exceed the maximum speed (voltage) for the selected heat pump family and size. The blower speed will not be adjusted further for 90 seconds after transition from first to second stage operation.

When making VFD speed adjustments for LAT control, the VFD speed should never go above the maximum speed (voltage) or below the minimum speed (voltage), for the selected heat pump family and size.

CONTINUOUS FAN VFD OPERATION

When the CXM2 is configured for VFD blower operation, the continuous fan operating speed will be a selectable value. The default continuous fan operating speeds (default fan speeds) are shown in Table 6, along with the minimum and maximum operating speed values.

NOTE: In VFD operation (Blower Type = 128), the VFD enable signal is triggered by the K1 relay. A01 output voltage for continuous fan operation will change to a percentage for the selected blower speed from the values presented in Table 6 or for full load airflow needs.

VFD Operation

Models:
SB
072-300

Table 6: VFD Control Values

Model	Minimum VFD Speed	Maximum VFD Speed	VFD Fixed Speed A	VFD Fixed Speed B	VFD Fixed Speed C	Part Load Multiplier	Default Fan Speed
SB072	3.7	10.0	7.4	6.2	9.0	71%	5.2
SB096	3.8	10.0	7.0	6.0	9.0	75%	5.0
SB120	4.2	10.0	8.0	7.0	9.0	70%	6.0
SB168	4.1	10.0	7.9	6.4	9.0	76%	5.4
SB192	4.4	10.0	8.0	7.0	9.0	73%	6.0
SB240	4.2	10.0	8.0	7.0	9.0	70%	6.0
SB300	5.0	10.0	8.0	8.0	9.5	71%	7.0

Table 7: Operating Temperatures

Model	Minimum Heat LAT	Maximum Heat LAT	Default Heat LAT	Minimum Cool LAT	Maximum Cool LAT	Default Cool LAT
SB072	85°	125°	105°	45°	65°	55°
SB096	85°	125°	105°	45°	65°	55°
SB120	85°	125°	105°	45°	65°	55°
SB168	85°	125°	105°	45°	65°	55°
SB192	85°	125°	105°	45°	65°	55°
SB240	85°	125°	105°	45°	65°	55°
SB300	85°	125°	105°	45°	65°	55°

ADVANCED CONTROL ALGORITHM

Option: The CXM2 is a communicating controller which also features two-stage control of cooling and two-stage control of heating modes for exacting temperature and dehumidification purposes. This control system coupled with a multi-stage thermostat will better dehumidify room air by automatically running the heat pump’s fan at lower speed on the first stage of cooling thereby implementing low sensible-heat-ratio cooling.

When higher cooling performance is needed, the system will activate the second stage of cooling and automatically switch the fan to the higher fan speed setting.

When CXM2 is connected to either ACDU service tool or AWC thermostat the installer/service technician can check and set CFM, toggle between discrete and LAT modes, select fixed fan speed, or LAT set point.

Models:
SB
072-300

Tensioning V-Belt Drives

GENERAL RULES OF TENSIONING

1. Ideal tension is the lowest tension at which the belt will not slip under peak load conditions.
2. Check tension frequently during the first 24-48 hours of operation.
3. Over tensioning shortens belt and bearing life.
4. Keep belts free from foreign material which may cause slip.
5. Inspect the V-drive on a periodic basis. Tension when slipping. Never apply belt dressing as this will damage the belt and cause early failure.

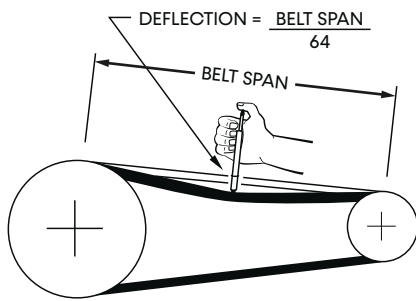

TENSION MEASUREMENT PROCEDURE

6. Measure the belt span (see sketch).
7. Position bottom of the large "O" ring on the span scale at the measured belt span.
8. Set the small "O" ring on the deflection force scale to zero.
9. Place the tension checker squarely on one belt at the center of the belt span. Apply a force on the plunger and perpendicular to the belt span until the bottom of the large "O" ring is even with the top of the next belt or with the bottom of a straight edge laid across the sheaves.
10. Remove the tension checker and read the force applied from the bottom of the small "O" ring on the deflection force scale.
11. Compare the force you have applied with the values given in the table below. The force should be between the minimum and maximum shown. The maximum value is shown for "New Belt" and new belts should be tensioned at this value to allow for expected tension loss. Used belts should be maintained at the minimum value as indicated in the table below.

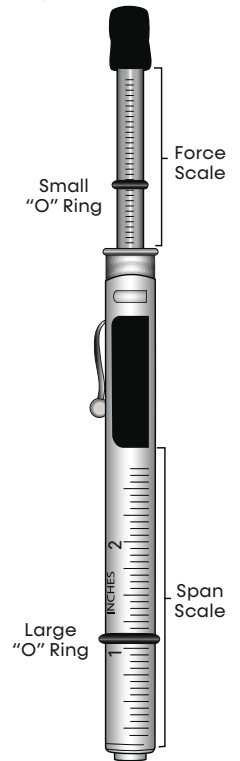

NOTE: The ratio of deflection to belt span is 1:64.

Cross Section	Smallest Sheave Diameter Range	RPM Range	Belt Deflection Force			
			Super Gripbelts and Unnotched Gripbands		Gripnotch Belts and Notched Gripbands	
			Used Belt	New Belt	Used Belt	New Belt
A, AX	7.6 - 9.1	1000 - 2500	16.458	24.464	18.237	27.133
		2501 - 4000	12.454	18.682	15.123	22.240
	9.6 - 12.2	1000 - 2500	20.016	30.246	22.240	32.915
B, BX	8.6 - 10.7	1000 - 2500	-	-	21.795	32.026
		2501 - 4000	-	-	18.682	27.578
	11.2 - 14.2	1000 - 2500	23.574	35.139	36.029	46.704
B, BX	11.2 - 14.2	2501 - 4000	20.016	29.802	31.581	40.477
		8.6 - 2500	28.022	41.811	37.808	56.045
	14.7 - 21.8	2501 - 4000	26.688	39.587	32.470	48.483

Blower Sheave Information

Horizontal

Model Size	Drive Package	Sheave			Belt
		Motor	Blower	Bushing	
72	1,A	1VP34 X 7/8 B	BK67 X 1 B	-	V-BELT BX47
	2,B	1VP34 X 7/8 B	BK85 X 1 B	-	V-BELT BX50
	3,C	1VP44 X 7/8 B	BK67 X 1 B	-	V-BELT BX48
	4,D	1VP34 X 7/8 B	BK67 X 1 B	-	V-BELT BX47
	5,6,E,F	1VP44 X 7/8 B	BK67 X 1 B	-	V-BELT BX48
96	1,A	1VP40 X 7/8 B	BK67 X 1 B	-	V-BELT BX47
	2,B	1VP34 X 7/8 B	BK77 X 1 B	-	V-BELT BX48
	3,C	1VP44 X 7/8 B	BK62H	-	V-BELT BX47
	4,D	1VP40 X 7/8 B	BK67 X 1 B	-	V-BELT B49
	5,6,E,F	1VP44 X 7/8 B	BK62H	-	V-BELT B49
120	1,A	1VP44 X 7/8 B	BK67 X 1 B	-	V-BELT BX50
	2,B	1VP34 X 7/8 B	BK67 X 1 B	-	V-BELT B49
	3,C	1VP50 X 7/8 B	BK67 X 1 B	-	V-BELT BX51
	4,D	1VP44 X 1-1/8	BK67 X 1 B	-	V-BELT BX50
	5,6,E,F	1VP50 X 1-1/8 B	BK67 X 1 B	-	V-BELT BX51

Vertical

Model Size	Drive Package	Sheave			Belt
		Motor	Blower	Bushing	
72	1,A	1VP34 X 7/8 B	BK67 X 1 B	-	V-BELT BX56
	2,B	1VP34 X 7/8 B	BK85 X 1 B	-	V-BELT BX59
	3,C	1VP44 X 7/8 B	BK67 X 1 B	-	V-BELT BX57
	4,D	1VP34 X 7/8 B	BK67 X 1 B	-	V-BELT BX56
	5,6,E,F	1VP44 X 7/8 B	BK67 X 1 B	-	V-BELT BX57
	96	1,A	1VP40 X 7/8 B	BK67 X 1 B	-
2,B		1VP34 X 7/8 B	BK77 X 1 B	-	V-BELT BX57
3,C		1VP44 X 7/8 B	BK62H	-	V-BELT BX56
4,D		1VP40 X 7/8 B	BK67 X 1 B	-	V-BELT BX54
5,6,E,F		1VP44 X 7/8 B	BK62H	-	V-BELT BX54
120		1,A	1VP44 X 7/8 B	BK67 X 1 B	-
	2,B	1VP34 X 7/8 B	BK67 X 1 B	-	V-BELT BX54
	3,C	1VP50 X 7/8 B	BK67 X 1 B	-	V-BELT BX56
	4,D	1VP44 X 1-1/8	BK67 X 1 B	-	V-BELT BX55
	5,6,E,F	1VP50 X 1-1/8 B	BK67 X 1 B	-	V-BELT BX56
	168	1,A	1VP44 X 7/8 B	BK80H	H x 1-3.16
2,B		1VP40 X 7/8 B	BK80H	H x 1-3.16	V-BELT BX51
3,C		1VP50 X 7/8 B	BK80H	H x 1-3.16	V-BELT BX52
4,D		1VP44 X 1-1/8	BK80H	H x 1-3.16	V-BELT BX51
5,6,E,F		1VP50 X 1-1/8 B	BK80H	H x 1-3.16	V-BELT BX52
192	1,A	1VP44 X 7/8 B	BK77H	H x 1-3.16	V-BELT BX51
	2,B	1VP44 X 7/8 B	BK95H	H x 1-3.16	V-BELT BX54
	3,C	1VP50 X 7/8 B	BK70H	H x 1-3.16	V-BELT BX51
	4,D	1VP44 X 1-1/8	BK77H	H x 1-3.16	V-BELT BX51
	5,6,E,F	1VP50 X 1-1/8 B	BK70H	H x 1-3.16	V-BELT BX51
240	1,A	1VP60 X 1-1/8 B	BK90H	H x 1-3.16	V-BELT BX55
	2,B	1VP50 X 1-1/8 B	BK90H	H x 1-3.16	V-BELT BX54
	3,C	1VP60 X 1-1/8 B	BK80H	H x 1-3.16	V-BELT BX53
	6,F	2VP60 X 1-3/8	2BK80H	H x 1-3.16	V-BELT BX52
300	6,F	2VP62 X 1-3/8	2BK80H	H x 1-3.16	V-BELT BX53

Models:
SB
072-300

Blower Performance

SB072

SCFM	ESP (in.w.c.)	0.00	0.10	0.20	0.30	0.40	0.50	0.60	0.70	0.80	0.90	1.00	1.10	1.20	1.30	1.40	1.50
1,800	BHP			0.28	0.32	0.35	0.39	0.42	0.45	0.48	0.52	0.56	0.60	0.64	0.69	0.72	0.76
	Sheave/Mtr			B	B	B	A	A	A	A	A	A	C	C	C	C	C
	RPM			599	645	690	735	775	815	850	885	910	940	965	995	1015	1040
1,900	BHP			0.31	0.36	0.40	0.44	0.49	0.53	2.50	0.62	0.65	0.69	0.73	0.76	0.80	0.84
	Sheave/Mtr			B	B	A	A	A	A	A	A	C	C	C	C	C	C
	RPM			604	655	695	740	780	820	855	890	920	950	980	1005	1030	1055
2,000	BHP		0.31	0.34	0.39	0.45	0.50	0.54	0.59	0.63	0.67	0.72	0.75	0.79	0.82	0.86	0.90
	Sheave/Mtr		B	B	B	A	A	A	A	A	A	C	C	C	C	C	C
	RPM		568	615	660	705	750	785	825	860	895	930	960	990	1015	1040	1065
2,100	BHP	0.33	0.38	0.42	0.46	0.50	0.54	0.59	0.65	0.70	0.74	0.78	0.81	0.85	0.89	0.94	0.98
	Sheave/Mtr	B	B	B	A	A	A	A	A	A	A	C	C	C	C	C	C
	RPM	531	583	630	670	715	755	795	835	875	905	940	970	1000	1025	1055	1080
2,200	BHP	0.37	0.40	0.45	0.49	0.55	0.60	0.65	0.70	0.75	0.79	0.83	0.87	0.92	0.96	1.00	1.04
	Sheave/Mtr	B	B	B	A	A	A	A	A	A	C	C	C	C	C	E	E
	RPM	552	599	645	685	730	770	810	850	885	915	950	980	1010	1040	1065	1090
2,300	BHP	0.42	0.47	0.51	0.56	0.60	0.65	0.70	0.75	0.80	0.84	0.89	0.94	1.00	1.05	1.10	1.16
	Sheave/Mtr	B	B	B	A	A	A	A	A	A	C	C	C	E	E	E	E
	RPM	573	620	660	705	745	785	820	860	895	925	960	990	1020	1050	1075	1105
2,400	BHP	0.48	0.52	0.57	0.61	0.66	0.72	0.78	0.83	0.87	0.92	0.97	1.02	1.07	1.13	1.19	1.25
	Sheave/Mtr	B	B	A	A	A	A	A	A	A	C	C	E	E	E	E	E
	RPM	604	645	690	730	765	805	845	880	910	945	975	1010	1035	1065	1095	1125
2,500	BHP	0.52	0.57	0.61	0.66	0.72	0.78	0.83	0.89	0.94	1.00	1.03	1.08	1.14	1.20	1.25	1.31
	Sheave/Mtr	B	B	A	A	A	A	A	A	C	E	E	E	E	E	E	E
	RPM	620	660	700	740	780	815	850	885	920	950	985	1015	1045	1075	1100	1130
2,600	BHP	0.56	0.61	0.66	0.70	0.76	0.82	0.88	0.93	0.98	1.04	1.08	1.14	1.20	1.26	1.32	1.37
	Sheave/Mtr	B	A	A	A	A	A	A	A	C	E	E	E	E	E	E	E
	RPM	635	675	715	750	790	825	860	895	925	960	990	1020	1050	1080	1110	1135
2,700	BHP	0.61	0.66	0.71	0.76	0.82	0.87	0.93	0.98	1.04	1.10	1.15	1.21	1.27	1.33	1.39	1.45
	Sheave/Mtr	B	A	A	A	A	A	A	A	E	E	E	E	E	E	E	E
	RPM	655	695	730	770	805	840	875	905	940	970	1000	1030	1060	1090	1120	1145
2,800	BHP	0.66	0.72	0.77	0.83	0.88	0.93	0.99	1.05	1.11	1.16	1.22	1.30	1.37	1.44	1.51	1.57
	Sheave/Mtr	B	A	A	A	A	A	A	D	E	E	E	E	E	E	E	E
	RPM	670	710	750	785	815	850	885	915	950	980	1010	1040	1070	1100	1130	1155
2,900	BHP	0.71	0.77	0.82	0.87	0.93	0.98	1.04	1.10	1.16	1.22	1.30	1.36	1.43	1.50	1.57	1.63
	Sheave/Mtr	A	A	A	A	A	A	D	E	E	E	E	E	E	E	E	E
	RPM	685	725	765	795	830	860	895	925	955	985	1020	1045	1075	1105	1135	1160
3,000	BHP	0.79	0.84	0.90	0.95	1.01	1.07	1.13	1.19	1.25	1.31	1.38	1.46	1.52	1.59	1.66	
	Sheave/Mtr	A	A	A	A	A	D	D	E	E	E	E	E	E	E	E	
	RPM	710	745	780	815	850	885	915	945	975	1005	1035	1065	1090	1120	1150	

- Notes:
- A, 1 = Standard RPM/Standard Blower Motor
 - E, 5 = High RPM/Large Blower Motor
 - The maximum allowable altitude of installation for this product is 6,561 ft (2,000 m).

Blower Performance SB072 with VFD

Models:
SB
072-300

SCFM	ESP (in.w.c.)	0.00	0.10	0.20	0.30	0.40	0.50	0.60	0.70	0.80	0.90	1.00	1.10	1.20	1.30	1.40	1.50	
1,800	BHP			0.28	0.32	0.35	0.39	0.42	0.45	0.48	0.52	0.56	0.60	0.64	0.69	0.72	0.76	
	Discrete Spd Setting			B	B	B	A	A	A	A	A	A	C	C	C	C	C	
	RPM			599	645	690	735	775	815	850	885	910	940	965	995	1015	1040	
1,900	BHP			0.31	0.36	0.40	0.44	0.49	0.53	2.50	0.62	0.65	0.69	0.73	0.76	0.80	0.84	
	Discrete Spd Setting			B	B	A	A	A	A	A	A	C	C	C	C	C	C	
	RPM			604	655	695	740	780	820	855	890	920	950	980	1005	1030	1055	
2,000	BHP		0.31	0.34	0.39	0.45	0.50	0.54	0.59	0.63	0.67	0.72	0.75	0.79	0.82	0.86	0.90	
	Discrete Spd Setting			B	B	B	A	A	A	A	A	C	C	C	C	C	C	
	RPM			568	615	660	705	750	785	825	860	895	930	960	990	1015	1040	1065
2,100	BHP	0.33	0.38	0.42	0.46	0.50	0.54	0.59	0.65	0.70	0.74	0.78	0.81	0.85	0.89	0.94	0.98	
	Discrete Spd Setting			B	B	B	A	A	A	A	A	C	C	C	C	C	C	
	RPM			531	583	630	670	715	755	795	835	875	905	940	970	1000	1025	1055
2,200	BHP	0.37	0.40	0.45	0.49	0.55	0.60	0.65	0.70	0.75	0.79	0.83	0.87	0.92	0.96	1.00	1.04	
	Discrete Spd Setting			B	B	B	A	A	A	A	C	C	C	C	C	E	E	
	RPM			552	599	645	685	730	770	810	850	885	915	950	980	1010	1040	1065
2,300	BHP	0.42	0.47	0.51	0.56	0.60	0.65	0.70	0.75	0.80	0.84	0.89	0.94	1.00	1.05	1.10	1.16	
	Discrete Spd Setting			B	B	B	A	A	A	A	C	C	C	C	C	C	C	
	RPM			573	620	660	705	745	785	820	860	895	925	960	990	1020	1050	1075
2,400	BHP	0.48	0.52	0.57	0.61	0.66	0.72	0.78	0.83	0.87	0.92	0.97	1.02	1.07	1.13	1.19	1.25	
	Discrete Spd Setting			B	B	A	A	A	A	A	C	C	C	C	C	C	C	
	RPM			604	645	690	730	765	805	845	880	910	945	975	1010	1035	1065	1095
2,500	BHP	0.52	0.57	0.61	0.66	0.72	0.78	0.83	0.89	0.94	1.00	1.03	1.08	1.14	1.20	1.25	1.31	
	Discrete Spd Setting			B	B	A	A	A	A	C	C	C	C	C	C	C	C	
	RPM			620	660	700	740	780	815	850	885	920	950	985	1015	1045	1075	1100
2,600	BHP	0.56	0.61	0.66	0.70	0.76	0.82	0.88	0.93	0.98	1.04	1.08	1.14	1.20	1.26	1.32	1.37	
	Discrete Spd Setting			B	A	A	A	A	A	C	C	C	C	C	C	C	C	
	RPM			635	675	715	750	790	825	860	895	925	960	990	1020	1050	1080	1110
2,700	BHP	0.61	0.66	0.71	0.76	0.82	0.87	0.93	0.98	1.04	1.10	1.15	1.21	1.27	1.33	1.39	1.45	
	Discrete Spd Setting			B	A	A	A	A	A	C	C	C	C	C	C	C	C	
	RPM			655	695	730	770	805	840	875	905	940	970	1000	1030	1060	1090	1120
2,800	BHP	0.66	0.72	0.77	0.83	0.88	0.93	0.99	1.05	1.11	1.16	1.22	1.30	1.37	1.44	1.51	1.57	
	Discrete Spd Setting			B	A	A	A	A	A	C	C	C	C	C	C	C	C	
	RPM			670	710	750	785	815	850	885	915	950	980	1010	1040	1070	1100	1130
2,900	BHP	0.71	0.77	0.82	0.87	0.93	0.98	1.04	1.10	1.16	1.22	1.30	1.36	1.43	1.50	1.57		
	Discrete Spd Setting			A	A	A	A	A	A	C	C	C	C	C	C	C	C	
	RPM			685	725	765	795	830	860	895	925	955	985	1020	1045	1075	1105	1135
3,000	BHP	0.79	0.84	0.90	0.95	1.01	1.07	1.13	1.19	1.25	1.31	1.38	1.46	1.52	1.59			
	Discrete Spd Setting			A	A	A	A	A	A	C	C	C	C	C	C	C	C	
	RPM			710	745	780	815	850	885	915	945	975	1005	1035	1065	1090	1120	

- Notes:
- Motor Sheave set to 1-turn open from factory.
 - Factory torque setting is A. Torque setting is field-adjustable to any torque setting listed in drive table through the ACDU01 Service Tool.
 - The unit can control the blower through LAT control. Enable this setting in the field with the ACDU01 Service Tool.
 - You can purchase the Advanced control panel as an accessory.
 - The maximum allowable altitude of installation for this product is 6,561 ft (2,000 m).

Models:
SB
072-300

Blower Performance

SB096

SCFM	ESP (in.w.c.)	0.00	0.10	0.20	0.30	0.40	0.50	0.60	0.70	0.80	0.90	1.00	1.10	1.20	1.30	1.40	1.50
2,400	BHP	0.45	0.50	0.54	0.59	0.63	0.69	0.74	0.80	0.85	0.90	0.94	0.99	1.04	1.10	1.16	1.22
	Sheave/Mtr	B	B	B	B	B	A	A	A	A	A	A	A	A	A	C	C
	RPM	578	625	665	705	745	785	820	860	895	925	960	990	1020	1050	1080	1110
2,500	BHP	0.50	0.55	0.59	0.64	0.69	0.75	0.81	0.88	0.92	0.97	1.01	1.06	1.12	1.17	1.23	1.29
	Sheave/Mtr	B	B	B	B	A	A	A	A	A	A	A	A	A	C	C	C
	RPM	599	645	685	725	765	800	835	875	905	940	970	1005	1035	1060	1090	1120
2,600	BHP	0.55	0.60	0.65	0.69	0.75	0.80	0.86	0.92	0.97	1.02	1.08	1.13	1.19	1.25	1.30	1.36
	Sheave/Mtr	B	B	B	B	A	A	A	A	A	A	A	A	A	C	C	C
	RPM	625	665	705	740	780	815	850	885	920	950	985	1015	1045	1075	1100	1130
2,700	BHP	0.60	0.65	0.70	0.75	0.80	0.86	0.91	0.97	1.02	1.08	1.14	1.20	1.26	1.32	1.38	1.44
	Sheave/Mtr	B	B	B	A	A	A	A	A	A	A	A	A	C	C	C	C
	RPM	645	685	725	760	795	830	865	900	930	960	995	1025	1055	1085	1115	1140
2,800	BHP	0.65	0.71	0.76	0.82	0.87	0.93	0.98	1.04	1.10	1.16	1.21	1.28	1.36	1.43	1.50	1.56
	Sheave/Mtr	B	B	B	A	A	A	A	A	A	A	A	A	C	C	C	C
	RPM	665	705	745	780	810	845	880	910	945	975	1005	1035	1065	1095	1125	1150
2,900	BHP	0.71	0.76	0.82	0.87	0.92	0.98	1.03	1.09	1.16	1.22	1.29	1.36	1.43	1.50	1.57	1.63
	Sheave/Mtr	B	B	A	A	A	A	A	A	A	A	A	A	C	C	C	C
	RPM	685	720	760	795	825	860	890	920	955	985	1015	1045	1075	1105	1135	1160
3,000	BHP	0.78	0.84	0.89	0.95	1.00	1.06	1.12	1.18	1.24	1.30	1.37	1.43	1.50	1.58	1.64	1.71
	Sheave/Mtr	B	B	A	A	A	A	A	A	A	A	A	C	C	C	C	C
	RPM	700	740	775	810	845	880	910	940	970	1000	1030	1055	1085	1115	1140	1170
3,100	BHP	0.85	0.91	0.96	1.02	1.08	1.14	1.22	1.29	1.36	1.44	1.50	1.57	1.63	1.70	1.76	1.82
	Sheave/Mtr	B	B	A	A	A	A	A	A	A	A	A	C	C	C	C	C
	RPM	720	755	790	825	860	890	925	955	985	1015	1040	1070	1095	1125	1150	1175
3,200	BHP	0.93	1.00	1.07	1.14	1.20	1.26	1.32	1.38	1.44	1.51	1.57	1.64	1.70	1.78	1.85	1.92
	Sheave/Mtr	B	A	A	A	A	A	A	A	A	A	C	C	C	C	C	C
	RPM	740	775	810	845	875	905	935	965	995	1025	1050	1080	1105	1135	1160	1185
3,300	BHP	1.01	1.08	1.14	1.21	1.28	1.33	1.39	1.45	1.51	1.58	1.64	1.72	1.78	1.84	1.93	2.00
	Sheave/Mtr	B	A	A	A	A	A	A	A	A	A	C	C	C	C	C	E
	RPM	755	790	820	855	890	915	945	975	1005	1035	1060	1090	1115	1140	1170	1195
3,400	BHP	1.08	1.15	1.22	1.29	1.35	1.41	1.47	1.53	1.59	1.68	1.75	1.83	1.90	1.96	2.02	2.08
	Sheave/Mtr	A	A	A	A	A	A	A	A	A	A	C	C	C	C	E	E
	RPM	765	800	835	870	900	930	960	990	1015	1045	1070	1100	1125	1150	1175	1200
3,500	BHP	1.16	1.23	1.29	1.36	1.42	1.48	1.54	1.60	1.66	1.73	1.79	1.85	1.92	2.01	2.09	2.17
	Sheave/Mtr	A	A	A	A	A	A	A	A	A	C	C	C	C	E	E	E
	RPM	780	815	845	880	910	940	970	1000	1025	1055	1080	1105	1130	1160	1185	1210

Notes:

- A, 1 = Standard RPM/Standard Blower Motor
- E, 5 = High RPM/Large Blower Motor
- The maximum allowable altitude of installation for this product is 6,561 ft (2,000 m).

Table continued on next page.

Blower Performance SB096

Models:
SB
072-300

Table continued from previous page.

SCFM	ESP (in.w.c.)	0.00	0.10	0.20	0.30	0.40	0.50	0.60	0.70	0.80	0.90	1.00	1.10	1.20	1.30	1.40	1.50
3,600	BHP	1.24	1.30	1.37	1.44	1.51	1.58	1.65	1.72	1.78	1.86	1.92	1.98	2.06	2.13	2.21	2.29
	Sheave/Mtr	A	A	A	A	A	A	A	A	A	C	C	C	E	E	E	E
	RPM	795	825	860	890	920	950	980	1010	1035	1065	1090	1115	1145	1165	1190	1215
3,700	BHP	1.34	1.40	1.46	1.53	1.61	1.68	1.75	1.82	1.90	1.97	2.06	2.13	2.21	2.28	2.36	2.44
	Sheave/Mtr	A	A	A	A	A	A	A	A	C	C	E	E	E	E	E	E
	RPM	820	850	880	910	940	970	1000	1025	1055	1080	1110	1135	1160	1180	1205	1230
3,800	BHP	1.43	1.49	1.56	1.63	1.70	1.78	1.86	1.94	2.02	2.12	2.20	2.28	2.34	2.42	2.50	2.58
	Sheave/Mtr	A	A	A	A	A	A	A	A	E	E	E	E	E	E	E	E
	RPM	840	870	900	930	960	990	1020	1045	1070	1100	1125	1150	1170	1195	1220	1245
3,900	BHP	1.58	1.64	1.71	1.78	1.85	1.93	2.01	2.09	2.19	2.27	2.35	2.41	2.49	2.57	2.65	
	Sheave/Mtr	A	A	A	A	A	A	D	D	E	E	E	E	E	E	E	
	RPM	865	890	920	950	980	1010	1035	1060	1090	1115	1140	1160	1185	1210	1235	
4,000	BHP	1.68	1.75	1.83	1.92	2.00	2.08	2.16	2.26	2.34	2.42	2.50	2.56	2.64	2.72	2.80	
	Sheave/Mtr	A	A	A	A	D	D	D	E	E	E	E	E	E	E	E	
	RPM	885	910	940	970	1000	1025	1050	1080	1105	1130	1155	1175	1200	1225	1250	

- Notes:
- A, 1 = Standard RPM/Standard Blower Motor
 - E, 5 = High RPM/Large Blower Motor
 - The maximum allowable altitude of installation for this product is 6,561 ft (2,000 m).

Models:
SB
072-300

Blower Performance SB096 with VFD

SCFM	ESP (in.w.c.)	0.00	0.10	0.20	0.30	0.40	0.50	0.60	0.70	0.80	0.90	1.00	1.10	1.20	1.30	1.40	1.50
2,400	BHP	0.45	0.50	0.54	0.59	0.63	0.69	0.74	0.80	0.85	0.90	0.94	0.99	1.04	1.10	1.16	1.22
	Discrete Spd Setting	B	B	B	B	B	A	A	A	A	A	A	A	A	A	C	C
	RPM	578	625	665	705	745	785	820	860	895	925	960	990	1020	1050	1080	1110
2,500	BHP	0.50	0.55	0.59	0.64	0.69	0.75	0.81	0.88	0.92	0.97	1.01	1.06	1.12	1.17	1.23	1.29
	Discrete Spd Setting	B	B	B	B	A	A	A	A	A	A	A	A	A	C	C	C
	RPM	599	645	685	725	765	800	835	875	905	940	970	1005	1035	1060	1090	1120
2,600	BHP	0.55	0.60	0.65	0.69	0.75	0.80	0.86	0.92	0.97	1.02	1.08	1.13	1.19	1.25	1.30	1.36
	Discrete Spd Setting	B	B	B	B	A	A	A	A	A	A	A	A	A	C	C	C
	RPM	625	665	705	740	780	815	850	885	920	950	985	1015	1045	1075	1100	1130
2,700	BHP	0.60	0.65	0.70	0.75	0.80	0.86	0.91	0.97	1.02	1.08	1.14	1.20	1.26	1.32	1.38	1.44
	Discrete Spd Setting	B	B	B	A	A	A	A	A	A	A	A	A	C	C	C	C
	RPM	645	685	725	760	795	830	865	900	930	960	995	1025	1055	1085	1115	1140
2,800	BHP	0.65	0.71	0.76	0.82	0.87	0.93	0.98	1.04	1.10	1.16	1.21	1.28	1.36	1.43	1.50	1.56
	Discrete Spd Setting	B	B	B	A	A	A	A	A	A	A	A	A	C	C	C	C
	RPM	665	705	745	780	810	845	880	910	945	975	1005	1035	1065	1095	1125	1150
2,900	BHP	0.71	0.76	0.82	0.87	0.92	0.98	1.03	1.09	1.16	1.22	1.29	1.36	1.43	1.50	1.57	1.63
	Discrete Spd Setting	B	B	A	A	A	A	A	A	A	A	A	A	C	C	C	C
	RPM	685	720	760	795	825	860	890	920	955	985	1015	1045	1075	1105	1135	1160
3,000	BHP	0.78	0.84	0.89	0.95	1.00	1.06	1.12	1.18	1.24	1.30	1.37	1.43	1.50	1.58	1.64	1.71
	Discrete Spd Setting	B	B	A	A	A	A	A	A	A	A	A	C	C	C	C	C
	RPM	700	740	775	810	845	880	910	940	970	1000	1030	1055	1085	1115	1140	1170
3,100	BHP	0.85	0.91	0.96	1.02	1.08	1.14	1.22	1.29	1.36	1.44	1.50	1.57	1.63	1.70	1.76	1.82
	Discrete Spd Setting	B	B	A	A	A	A	A	A	A	A	A	C	C	C	C	C
	RPM	720	755	790	825	860	890	925	955	985	1015	1040	1070	1095	1125	1150	1175
3,200	BHP	0.93	1.00	1.07	1.14	1.20	1.26	1.32	1.38	1.44	1.51	1.57	1.64	1.70	1.78	1.85	1.92
	Discrete Spd Setting	B	A	A	A	A	A	A	A	A	A	C	C	C	C	C	C
	RPM	740	775	810	845	875	905	935	965	995	1025	1050	1080	1105	1135	1160	1185
3,300	BHP	1.01	1.08	1.14	1.21	1.28	1.33	1.39	1.45	1.51	1.58	1.64	1.72	1.78	1.84	1.93	2.00
	Discrete Spd Setting	B	A	A	A	A	A	A	A	A	A	C	C	C	C	C	C
	RPM	755	790	820	855	890	915	945	975	1005	1035	1060	1090	1115	1140	1170	1195
3,400	BHP	1.08	1.15	1.22	1.29	1.35	1.41	1.47	1.53	1.59	1.68	1.75	1.83	1.90	1.96	2.02	2.08
	Discrete Spd Setting	A	A	A	A	A	A	A	A	A	A	C	C	C	C	C	C
	RPM	765	800	835	870	900	930	960	990	1015	1045	1070	1100	1125	1150	1175	1200

Notes:

- Motor Sheave set to 1-turn open from factory.
- Factory torque setting is A. Torque setting is field-adjustable to any torque setting listed in drive table through the ACDU01 Service Tool.
- The unit can control the blower through LAT control. Enable this setting in the field with the ACDU01 Service Tool.
- You can purchase the Advanced control panel as an accessory.
- The maximum allowable altitude of installation for this product is 6,561 ft (2,000 m).

Table continued on next page.

Blower Performance SB096 with VFD

Models:
SB
072-300

Table continued from previous page.

SCFM	ESP (in.w.c.)	0.00	0.10	0.20	0.30	0.40	0.50	0.60	0.70	0.80	0.90	1.00	1.10	1.20	1.30	1.40	1.50
3,500	BHP	1.16	1.23	1.29	1.36	1.42	1.48	1.54	1.60	1.66	1.73	1.79	1.85	1.92	2.01	2.09	2.17
	Discrete Spd Setting	A	A	A	A	A	A	A	A	A	C	C	C	C	C	C	C
	RPM	780	815	845	880	910	940	970	1000	1025	1055	1080	1105	1130	1160	1185	1210
3,600	BHP	1.24	1.30	1.37	1.44	1.51	1.58	1.65	1.72	1.78	1.86	1.92	1.98	2.06	2.13	2.21	2.29
	Discrete Spd Setting	A	A	A	A	A	A	A	A	A	C	C	C	C	C	C	C
	RPM	795	825	860	890	920	950	980	1010	1035	1065	1090	1115	1145	1165	1190	1215
3,700	BHP	1.34	1.40	1.46	1.53	1.61	1.68	1.75	1.82	1.90	1.97	2.06	2.13	2.21	2.28	2.36	2.44
	Discrete Spd Setting	A	A	A	A	A	A	A	A	C	C	C	C	C	C	C	C
	RPM	820	850	880	910	940	970	1000	1025	1055	1080	1110	1135	1160	1180	1205	1230
3,800	BHP	1.43	1.49	1.56	1.63	1.70	1.78	1.86	1.94	2.02	2.12	2.20	2.28	2.34	2.42	2.50	2.58
	Discrete Spd Setting	A	A	A	A	A	A	A	A	C	C	C	C	C	C	C	C
	RPM	840	870	900	930	960	990	1020	1045	1070	1100	1125	1150	1170	1195	1220	1245
3,900	BHP	1.58	1.64	1.71	1.78	1.85	1.93	2.01	2.09	2.19	2.27	2.35	2.41	2.49	2.57	2.65	
	Discrete Spd Setting	A	A	A	A	A	A	A	A	C	C	C	C	C	C	C	
	RPM	865	890	920	950	980	1010	1035	1060	1090	1115	1140	1160	1185	1210	1235	
4,000	BHP	1.68	1.75	1.83	1.92	2.00	2.08	2.16	2.26	2.34	2.42	2.50	2.56	2.64	2.72	2.80	
	Discrete Spd Setting	A	A	A	A	A	A	A	C	C	C	C	C	C	C	C	
	RPM	885	910	940	970	1000	1025	1050	1080	1105	1130	1155	1175	1200	1225	1250	

Notes:

- Motor Sheave set to 1-turn open from factory.
- Factory torque setting is A. Torque setting is field-adjustable to any torque setting listed in drive table through the ACDU01 Service Tool.
- The unit can control the blower through LAT control. Enable this setting in the field with the ACDU01 Service Tool.
- You can purchase the Advanced control panel as an accessory.
- The maximum allowable altitude of installation for this product is 6,561 ft (2,000 m).

Models:
SB
072-300

Blower Performance SB120

SCFM	ESP (in.w.c.)	0.00	0.10	0.20	0.30	0.40	0.50	0.60	0.70	0.80	0.90	1.00	1.10	1.20	1.30	1.40	1.50
3,000	BHP	0.75	0.81	0.86	0.91	0.97	1.03	1.09	1.15	1.21	1.27	1.34	1.41	1.47	1.54	1.61	1.67
	Sheave/Mtr	B	B	B	B	B	B	A	A	A	A	A	A	A	A	A	A
	RPM	680	720	755	790	825	860	895	925	955	985	1015	1045	1070	1100	1130	1155
3,100	BHP	0.82	0.88	0.94	0.99	1.04	1.10	1.17	1.26	1.33	1.40	1.46	1.53	1.59	1.66	1.72	1.80
	Sheave/Mtr	B	B	B	B	B	A	A	A	A	A	A	A	A	A	A	C
	RPM	700	735	775	805	840	875	905	940	970	1000	1025	1055	1080	1110	1135	1165
3,200	BHP	0.90	0.96	1.03	1.10	1.17	1.23	1.29	1.35	1.41	1.47	1.55	1.61	1.68	1.74	1.81	1.89
	Sheave/Mtr	B	B	B	B	B	A	A	A	A	A	A	A	A	A	A	C
	RPM	720	755	790	825	860	890	920	950	980	1010	1040	1065	1095	1120	1145	1175
3,300	BHP	0.98	1.04	1.11	1.18	1.25	1.31	1.37	1.43	1.49	1.55	1.62	1.68	1.75	1.81	1.88	1.95
	Sheave/Mtr	B	B	B	B	A	A	A	A	A	A	A	A	A	A	A	C
	RPM	740	770	805	840	875	905	935	965	995	1020	1050	1075	1105	1130	1155	1180
3,400	BHP	1.06	1.13	1.19	1.26	1.33	1.38	1.44	1.50	1.56	1.65	1.72	1.80	1.87	1.94	2.00	2.06
	Sheave/Mtr	B	B	B	B	A	A	A	A	A	A	A	A	A	A	C	C
	RPM	755	790	820	855	890	915	945	975	1005	1035	1060	1090	1115	1140	1165	1190
3,500	BHP	1.14	1.21	1.27	1.34	1.40	1.46	1.52	1.58	1.65	1.71	1.77	1.84	1.90	1.98	2.06	2.14
	Sheave/Mtr	B	B	B	A	A	A	A	A	A	A	A	A	A	A	C	C
	RPM	770	805	835	870	900	930	960	990	1020	1045	1070	1100	1125	1150	1175	1200
3,600	BHP	1.23	1.29	1.36	1.42	1.50	1.57	1.64	1.71	1.77	1.84	1.90	1.96	2.05	2.13	2.21	2.27
	Sheave/Mtr	B	B	B	A	A	A	A	A	A	A	A	A	A	C	C	C
	RPM	790	820	855	885	915	945	975	1005	1030	1060	1085	1110	1140	1165	1190	1210
3,700	BHP	1.32	1.38	1.44	1.51	1.58	1.65	1.73	1.81	1.88	1.96	2.03	2.10	2.18	2.26	2.34	2.42
	Sheave/Mtr	B	B	A	A	A	A	A	A	A	A	A	A	A	C	C	C
	RPM	810	840	870	900	930	960	990	1020	1045	1075	1100	1125	1150	1175	1200	1225
3,800	BHP	1.41	1.47	1.54	1.61	1.68	1.75	1.82	1.91	1.99	2.07	2.17	2.25	2.31	2.39	2.47	2.55
	Sheave/Mtr	B	B	A	A	A	A	A	A	A	A	A	A	A	C	C	C
	RPM	830	860	890	920	950	980	1005	1035	1060	1085	1115	1140	1160	1185	1210	1235
3,900	BHP	1.54	1.60	1.67	1.74	1.82	1.89	1.96	2.04	2.14	2.22	2.30	2.38	2.46	2.52	2.60	2.68
	Sheave/Mtr	B	A	A	A	A	A	A	A	A	A	A	A	C	C	C	C
	RPM	850	875	905	935	965	995	1020	1045	1075	1100	1125	1150	1175	1195	1220	1245
4,000	BHP	1.63	1.71	1.78	1.86	1.94	2.03	2.11	2.19	2.27	2.37	2.45	2.51	2.59	2.67	2.75	2.85
	Sheave/Mtr	A	A	A	A	A	A	A	A	A	A	A	A	C	C	C	C
	RPM	865	895	920	950	980	1010	1035	1060	1085	1115	1140	1160	1185	1210	1235	1260
4,100	BHP	1.73	1.81	1.90	1.97	2.05	2.12	2.20	2.27	2.34	2.42	2.52	2.62	2.70	2.80	2.90	
	Sheave/Mtr	A	A	A	A	A	A	A	A	A	A	A	C	C	C	C	
	RPM	885	915	945	970	1000	1025	1055	1080	1105	1130	1155	1180	1200	1225	1250	
4,200	BHP	1.87	1.94	2.02	2.08	2.16	2.24	2.32	2.40	2.48	2.58	2.68	2.76	2.86	2.96		
	Sheave/Mtr	A	A	A	A	A	A	A	A	A	A	C	C	C	C		
	RPM	905	935	965	990	1020	1045	1070	1095	1120	1145	1170	1190	1215	1240		

- Notes:
- A, 1 = Standard RPM/Standard Blower Motor
 - E, 5 = High RPM/Large Blower Motor
 - The maximum allowable altitude of installation for this product is 6,561 ft (2,000 m).

Table continued on next page.

Blower Performance SB120

Models:
SB
072-300

Table continued from previous page.

SCFM	ESP (in.w.c.)	0.00	0.10	0.20	0.30	0.40	0.50	0.60	0.70	0.80	0.90	1.00	1.10	1.20	1.30	1.40	1.50
4,300	BHP	2.00	2.07	2.16	2.23	2.31	2.41	2.49	2.57	2.66	2.74	2.84	2.94	3.02	3.15		
	Sheave/Mtr	A	A	A	A	A	A	A	A	A	C	C	C	E	E		
	RPM	930	955	985	1010	1035	1065	1090	1115	1140	1160	1185	1210	1230	1255		
4,400	BHP	2.14	2.22	2.32	2.40	2.48	2.56	2.65	2.74	2.82	2.92	3.00	3.10	3.18			
	Sheave/Mtr	A	A	A	A	A	A	A	A	A	C	E	E	E			
	RPM	950	975	1005	1030	1055	1080	1110	1135	1155	1180	1200	1225	1245			
4,500	BHP	2.30	2.38	2.46	2.54	2.62	2.72	2.80	2.88	3.00	3.08	3.16	3.26				
	Sheave/Mtr	A	A	A	A	A	A	A	A	D	E	E	E				
	RPM	970	995	1020	1045	1070	1100	1125	1145	1170	1195	1215	1240				
4,600	BHP	2.39	2.45	2.54	2.63	2.72	2.83	2.92	3.00	3.10	3.18	3.28	3.38				
	Sheave/Mtr	A	A	A	A	A	A	A	D	D	E	E	E				
	RPM	980	1000	1025	1050	1075	1105	1130	1150	1175	1195	1220	1245				
4,700	BHP	2.46	2.52	2.62	2.72	2.82	2.92	3.02	3.12	3.22	3.32	3.40	3.50				
	Sheave/Mtr	A	A	A	A	A	A	D	D	E	E	E	E				
	RPM	985	1005	1030	1055	1080	1105	1130	1155	1180	1205	1225	1250				
4,800	BHP	2.57	2.64	2.74	2.84	2.94	3.04	3.14	3.24	3.32	3.42	3.52	3.60				
	Sheave/Mtr	A	A	A	A	A	D	D	D	E	E	E	E				
	RPM	990	1010	1035	1060	1085	1110	1135	1160	1180	1205	1230	1250				
4,900	BHP	2.68	2.78	2.88	3.00	3.06	3.16	3.26	3.36	3.44	3.54	3.64	3.75				
	Sheave/Mtr	A	A	A	D	D	D	D	E	E	E	E	E				
	RPM	995	1020	1045	1070	1090	1115	1140	1165	1185	1210	1235	1255				
5,000	BHP	2.82	2.92	3.00	3.10	3.20	3.28	3.38	3.48	3.56	3.66	3.74					
	Sheave/Mtr	A	A	D	D	D	D	D	E	E	E	E					
	RPM	1005	1030	1050	1075	1100	1120	1145	1170	1190	1215	1235					

Notes:

- A, 1 = Standard RPM/Standard Blower Motor
- E, 5 = High RPM/Large Blower Motor
- The maximum allowable altitude of installation for this product is 6,561 ft (2,000 m).

Models:
SB
072-300

Blower Performance SB120 with VFD

SCFM	ESP (in.w.c.)	0.00	0.10	0.20	0.30	0.40	0.50	0.60	0.70	0.80	0.90	1.00	1.10	1.20	1.30	1.40	1.50
3,000	BHP	0.75	0.81	0.86	0.91	0.97	1.03	1.09	1.15	1.21	1.27	1.34	1.41	1.47	1.54	1.61	1.67
	Discrete Spd Setting	B	B	B	B	B	B	A	A	A	A	A	A	A	A	A	A
	RPM	680	720	755	790	825	860	895	925	955	985	1015	1045	1070	1100	1130	1155
3,100	BHP	0.82	0.88	0.94	0.99	1.04	1.10	1.17	1.26	1.33	1.40	1.46	1.53	1.59	1.66	1.72	1.80
	Discrete Spd Setting	B	B	B	B	B	A	A	A	A	A	A	A	A	A	A	C
	RPM	700	735	775	805	840	875	905	940	970	1000	1025	1055	1080	1110	1135	1165
3,200	BHP	0.90	0.96	1.03	1.10	1.17	1.23	1.29	1.35	1.41	1.47	1.55	1.61	1.68	1.74	1.81	1.89
	Discrete Spd Setting	B	B	B	B	B	A	A	A	A	A	A	A	A	A	A	C
	RPM	720	755	790	825	860	890	920	950	980	1010	1040	1065	1095	1120	1145	1175
3,300	BHP	0.98	1.04	1.11	1.18	1.25	1.31	1.37	1.43	1.49	1.55	1.62	1.68	1.75	1.81	1.88	1.95
	Discrete Spd Setting	B	B	B	B	A	A	A	A	A	A	A	A	A	A	A	C
	RPM	740	770	805	840	875	905	935	965	995	1020	1050	1075	1105	1130	1155	1180
3,400	BHP	1.06	1.13	1.19	1.26	1.33	1.38	1.44	1.50	1.56	1.65	1.72	1.80	1.87	1.94	2.00	2.06
	Discrete Spd Setting	B	B	B	B	A	A	A	A	A	A	A	A	A	A	C	C
	RPM	755	790	820	855	890	915	945	975	1005	1035	1060	1090	1115	1140	1165	1190
3,500	BHP	1.14	1.21	1.27	1.34	1.40	1.46	1.52	1.58	1.65	1.71	1.77	1.84	1.90	1.98	2.06	2.14
	Discrete Spd Setting	B	B	B	A	A	A	A	A	A	A	A	A	A	A	C	C
	RPM	770	805	835	870	900	930	960	990	1020	1045	1070	1100	1125	1150	1175	1200
3,600	BHP	1.23	1.29	1.36	1.42	1.50	1.57	1.64	1.71	1.77	1.84	1.90	1.96	2.05	2.13	2.21	2.27
	Discrete Spd Setting	B	B	B	A	A	A	A	A	A	A	A	A	A	C	C	C
	RPM	790	820	855	885	915	945	975	1005	1030	1060	1085	1110	1140	1165	1190	1210
3,700	BHP	1.32	1.38	1.44	1.51	1.58	1.65	1.73	1.81	1.88	1.96	2.03	2.10	2.18	2.26	2.34	2.42
	Discrete Spd Setting	B	B	A	A	A	A	A	A	A	A	A	A	A	C	C	C
	RPM	810	840	870	900	930	960	990	1020	1045	1075	1100	1125	1150	1175	1200	1225
3,800	BHP	1.41	1.47	1.54	1.61	1.68	1.75	1.82	1.91	1.99	2.07	2.17	2.25	2.31	2.39	2.47	2.55
	Discrete Spd Setting	B	B	A	A	A	A	A	A	A	A	A	A	A	C	C	C
	RPM	830	860	890	920	950	980	1005	1035	1060	1085	1115	1140	1160	1185	1210	1235
3,900	BHP	1.54	1.60	1.67	1.74	1.82	1.89	1.96	2.04	2.14	2.22	2.30	2.38	2.46	2.52	2.60	2.68
	Discrete Spd Setting	B	A	A	A	A	A	A	A	A	A	A	A	C	C	C	C
	RPM	850	875	905	935	965	995	1020	1045	1075	1100	1125	1150	1175	1195	1220	1245
4,000	BHP	1.63	1.71	1.78	1.86	1.94	2.03	2.11	2.19	2.27	2.37	2.45	2.51	2.59	2.67	2.75	2.85
	Discrete Spd Setting	A	A	A	A	A	A	A	A	A	A	A	A	C	C	C	C
	RPM	865	895	920	950	980	1010	1035	1060	1085	1115	1140	1160	1185	1210	1235	1260
4,100	BHP	1.73	1.81	1.90	1.97	2.05	2.12	2.20	2.27	2.34	2.42	2.52	2.62	2.70	2.80	2.90	
	Discrete Spd Setting	A	A	A	A	A	A	A	A	A	A	A	C	C	C	C	
	RPM	885	915	945	970	1000	1025	1055	1080	1105	1130	1155	1180	1200	1225	1250	
4,200	BHP	1.87	1.94	2.02	2.08	2.16	2.24	2.32	2.40	2.48	2.58	2.68	2.76	2.86	2.96		
	Discrete Spd Setting	A	A	A	A	A	A	A	A	A	A	C	C	C	C		
	RPM	905	935	965	990	1020	1045	1070	1095	1120	1145	1170	1190	1215	1240		
4,300	BHP	2.00	2.07	2.16	2.23	2.31	2.41	2.49	2.57	2.66	2.74	2.84	2.94	3.02	3.15		
	Discrete Spd Setting	A	A	A	A	A	A	A	A	A	C	C	C	E	E		
	RPM	930	955	985	1010	1035	1065	1090	1115	1140	1160	1185	1210	1230	1255		

Notes:

- Motor Sheave set to 1-turn open from factory.
- Factory torque setting is A. Torque setting is field-adjustable to any torque setting listed in drive table through the ACDU01 Service Tool.
- The unit can control the blower through LAT control. Enable this settings in the field with the ACDU01 Service Tool.
- You can purchase the Advanced control panel as an accessory.
- The maximum allowable altitude of installation for this product is 6,561 ft (2,000 m).

Table continued on next page.

Blower Performance SB120 with VFD

Models:
SB
072-300

Table continued from previous page.

SCFM	ESP (in.w.c.)	0.00	0.10	0.20	0.30	0.40	0.50	0.60	0.70	0.80	0.90	1.00	1.10	1.20	1.30	1.40	1.50
4,400	BHP	2.14	2.22	2.32	2.40	2.48	2.56	2.65	2.74	2.82	2.92	3.00	3.10	3.18			
	Discrete Spd Setting	A	A	A	A	A	A	A	A	A	C	C	C	C			
	RPM	950	975	1005	1030	1055	1080	1110	1135	1155	1180	1200	1225	1245			
4,500	BHP	2.30	2.38	2.46	2.54	2.62	2.72	2.80	2.88	3.00	3.08	3.16	3.26				
	Discrete Spd Setting	A	A	A	A	A	A	A	A	A	C	C	C				
	RPM	970	995	1020	1045	1070	1100	1125	1145	1170	1195	1215	1240				
4,600	BHP	2.39	2.45	2.54	2.63	2.72	2.83	2.92	3.00	3.10	3.18	3.28	3.38				
	Discrete Spd Setting	A	A	A	A	A	A	A	A	A	C	C	C				
	RPM	980	1000	1025	1050	1075	1105	1130	1150	1175	1195	1220	1245				
4,700	BHP	2.46	2.52	2.62	2.72	2.82	2.92	3.02	3.12	3.22	3.32	3.40	3.50				
	Discrete Spd Setting	A	A	A	A	A	A	A	A	C	C	C	C				
	RPM	985	1005	1030	1055	1080	1105	1130	1155	1180	1205	1225	1250				
4,800	BHP	2.57	2.64	2.74	2.84	2.94	3.04	3.14	3.24	3.32	3.42	3.52	3.60				
	Discrete Spd Setting	A	A	A	A	A	A	A	A	C	C	C	C				
	RPM	990	1010	1035	1060	1085	1110	1135	1160	1180	1205	1230	1250				
4,900	BHP	2.68	2.78	2.88	3.00	3.06	3.16	3.26	3.36	3.44	3.54	3.64	3.75				
	Discrete Spd Setting	A	A	A	A	A	A	A	C	C	C	C	C				
	RPM	995	1020	1045	1070	1090	1115	1140	1165	1185	1210	1235	1255				
5,000	BHP	2.82	2.92	3.00	3.10	3.20	3.28	3.38	3.48	3.56	3.66	3.74					
	Discrete Spd Setting	A	A	A	A	A	A	A	C	C	C	C					
	RPM	1005	1030	1050	1075	1100	1120	1145	1170	1190	1215	1235					

Notes:

- Motor Sheave set to 1-turn open from factory.
- Factory torque setting is A. Torque setting is field-adjustable to any torque setting listed in drive table through the ACDU01 Service Tool.
- The unit can control the blower through LAT control. Enable this settings in the field with the ACDU01 Service Tool.
- You can purchase the Advanced control panel as an accessory.
- The maximum allowable altitude of installation for this product is 6,561 ft (2,000 m).

Models:
SB
072-300

Blower Performance

SB168

SCFM	ESP (in.w.c.)	0.00	0.10	0.20	0.30	0.40	0.50	0.60	0.70	0.80	0.90	1.00	1.10	1.20	1.30	1.40	1.50
4,200	BHP			0.69	0.78	0.86	0.95	1.02	1.11	1.21	1.32	1.41	1.50	1.57	1.64	1.72	1.80
	Sheave/Mtr			B	B	B	B	A	A	A	A	A	A	A	C	C	C
	RPM			547	594	640	685	725	765	805	845	880	915	945	975	1005	1030
4,400	BHP			0.75	0.83	0.92	1.01	1.11	1.21	1.31	1.41	1.51	1.60	1.68	1.76	1.85	1.94
	Sheave/Mtr			B	B	B	B	A	A	A	A	A	A	A	C	C	C
	RPM			563	609	655	695	735	775	815	855	890	925	955	985	1015	1045
4,600	BHP		0.75	0.85	0.95	1.03	1.11	1.19	1.30	1.40	1.50	1.60	1.70	1.78	1.89	2.00	2.10
	Sheave/Mtr		B	B	B	B	B	A	A	A	A	A	A	C	C	C	C
	RPM		526	573	625	665	705	745	785	825	860	895	930	960	995	1025	1050
4,800	BHP		0.83	0.94	1.03	1.12	1.20	1.30	1.40	1.53	1.63	1.73	1.82	1.92	2.00	2.12	2.22
	Sheave/Mtr		B	B	B	B	A	A	A	A	A	A	A	C	C	C	C
	RPM		542	594	640	680	720	760	795	835	870	905	935	970	1000	1030	1055
5,000	BHP		0.93	1.02	1.11	1.20	1.31	1.41	1.52	1.64	1.76	1.85	1.95	2.03	2.12	2.24	2.36
	Sheave/Mtr		B	B	B	B	A	A	A	A	A	A	A	C	C	C	C
	RPM		563	609	650	690	735	770	805	840	880	910	945	975	1005	1035	1065
5,200	BHP	0.93	1.02	1.10	1.20	1.29	1.39	1.50	1.61	1.72	1.83	1.94	2.06	2.15	2.26	2.38	2.50
	Sheave/Mtr	B	B	B	B	B	A	A	A	A	A	A	A	C	C	C	C
	RPM	542	583	625	665	705	745	780	815	850	885	920	955	985	1015	1045	1075
5,400	BHP	1.03	1.10	1.19	1.29	1.39	1.50	1.59	1.70	1.80	1.92	2.03	2.16	2.26	2.38	2.50	2.62
	Sheave/Mtr	B	B	B	B	B	A	A	A	A	A	A	C	C	C	C	C
	RPM	563	599	640	680	720	760	790	825	860	895	925	960	990	1020	1050	1080
5,600	BHP	1.12	1.19	1.28	1.39	1.50	1.61	1.72	1.84	1.93	2.06	2.17	2.29	2.40	2.54	2.69	2.83
	Sheave/Mtr	B	B	B	B	A	A	A	A	A	A	A	C	C	C	C	C
	RPM	583	620	655	695	735	770	805	840	870	905	935	970	1000	1030	1060	1090
5,800	BHP	1.17	1.28	1.39	1.49	1.60	1.70	1.81	1.90	2.02	2.14	2.28	2.40	2.52	2.67	2.81	2.96
	Sheave/Mtr	B	B	B	B	A	A	A	A	A	A	A	C	C	C	C	C
	RPM	588	630	670	710	750	780	815	845	880	910	945	975	1005	1035	1065	1095
6,000	BHP	1.25	1.40	1.51	1.61	1.73	1.84	1.94	2.05	2.18	2.30	2.42	2.54	2.67	2.79	2.94	3.08
	Sheave/Mtr	B	B	B	A	A	A	A	A	A	A	A	C	C	C	C	E
	RPM	604	645	685	720	760	795	825	860	895	925	955	985	1015	1040	1070	1100
6,200	BHP	1.40	1.51	1.62	1.75	1.86	1.98	2.09	2.20	2.34	2.49	2.63	2.78	2.92	3.06	3.18	
	Sheave/Mtr	B	B	B	A	A	A	A	A	A	A	C	C	C	E	E	
	RPM	625	660	695	735	770	805	840	875	905	935	965	995	1025	1055	1080	
6,400	BHP	1.55	1.68	1.79	1.90	2.04	2.18	2.32	2.44	2.56	2.68	2.80	2.92	3.07	3.19	3.33	
	Sheave/Mtr	B	B	B	A	A	A	A	A	A	A	C	C	E	E	E	
	RPM	640	680	715	750	785	820	855	885	915	945	975	1005	1035	1060	1090	
6,600	BHP	1.73	1.84	1.94	2.06	2.20	2.34	2.46	2.58	2.70	2.82	2.94	3.07	3.19	3.34	3.46	
	Sheave/Mtr	B	B	A	A	A	A	A	A	A	A	C	E	E	E	E	
	RPM	665	700	730	765	800	835	865	895	925	955	985	1015	1040	1070	1095	
6,800	BHP	1.87	1.98	2.08	2.20	2.34	2.48	2.62	2.74	2.86	2.96	3.08	3.24	3.38	3.55		
	Sheave/Mtr	B	B	A	A	A	A	A	A	A	C	E	E	E	E		
	RPM	685	715	745	775	810	845	880	910	940	965	995	1025	1050	1080		
7,000	BHP	2.03	2.13	2.22	2.36	2.50	2.62	2.76	2.88	3.00	3.12	3.22	3.37	3.49	3.61		
	Sheave/Mtr	B	A	A	A	A	A	A	A	D	E	E	E	E	E		
	RPM	705	730	755	790	825	855	890	920	950	980	1005	1035	1060	1085		

Notes:

- A, 1 = Standard RPM/Standard Blower Motor
- E, 5 = High RPM/Large Blower Motor
- The maximum allowable altitude of installation for this product is 6,561 ft (2,000 m).

Blower Performance SB168 with VFD

Models:
SB
072-300

SCFM	ESP (in.w.c.)	0.00	0.10	0.20	0.30	0.40	0.50	0.60	0.70	0.80	0.90	1.00	1.10	1.20	1.30	1.40	1.50	
4,200	BHP			0.69	0.78	0.86	0.95	1.02	1.11	1.21	1.32	1.41	1.50	1.57	1.64	1.72	1.80	
	Discrete Spd Setting			B	B	B	B	A	A	A	A	A	A	A	C	C	C	
	RPM			547	594	640	685	725	765	805	845	880	915	945	975	1005	1030	
4,400	BHP			0.75	0.83	0.92	1.01	1.11	1.21	1.31	1.41	1.51	1.60	1.68	1.76	1.85	1.94	
	Discrete Spd Setting			B	B	B	B	A	A	A	A	A	A	A	C	C	C	
	RPM			563	609	655	695	735	775	815	855	890	925	955	985	1015	1045	
4,600	BHP		0.75	0.85	0.95	1.03	1.11	1.19	1.30	1.40	1.50	1.60	1.70	1.78	1.89	2.00	2.10	
	Discrete Spd Setting		B	B	B	B	B	A	A	A	A	A	A	C	C	C	C	
	RPM		526	573	625	665	705	745	785	825	860	895	930	960	995	1025	1050	
4,800	BHP		0.83	0.94	1.03	1.12	1.20	1.30	1.40	1.53	1.63	1.73	1.82	1.92	2.00	2.12	2.22	
	Discrete Spd Setting		B	B	B	B	A	A	A	A	A	A	A	C	C	C	C	
	RPM		542	594	640	680	720	760	795	835	870	905	935	970	1000	1030	1055	
5,000	BHP		0.93	1.02	1.11	1.20	1.31	1.41	1.52	1.64	1.76	1.85	1.95	2.03	2.12	2.24	2.36	
	Discrete Spd Setting		B	B	B	B	A	A	A	A	A	A	A	C	C	C	C	
	RPM		563	609	650	690	735	770	805	840	880	910	945	975	1005	1035	1065	
5,200	BHP		0.93	1.02	1.10	1.20	1.29	1.39	1.50	1.61	1.72	1.83	1.94	2.06	2.15	2.26	2.38	2.50
	Discrete Spd Setting		B	B	B	B	B	A	A	A	A	A	A	A	C	C	C	C
	RPM		542	583	625	665	705	745	780	815	850	885	920	955	985	1015	1045	1075
5,400	BHP		1.03	1.10	1.19	1.29	1.39	1.50	1.59	1.70	1.80	1.92	2.03	2.16	2.26	2.38	2.50	2.62
	Discrete Spd Setting		B	B	B	B	B	A	A	A	A	A	A	C	C	C	C	C
	RPM		563	599	640	680	720	760	790	825	860	895	925	960	990	1020	1050	1080
5,600	BHP		1.12	1.19	1.28	1.39	1.50	1.61	1.72	1.84	1.93	2.06	2.17	2.29	2.40	2.54	2.69	2.83
	Discrete Spd Setting		B	B	B	B	A	A	A	A	A	A	A	C	C	C	C	C
	RPM		583	620	655	695	735	770	805	840	870	905	935	970	1000	1030	1060	1090
5,800	BHP		1.17	1.28	1.39	1.49	1.60	1.70	1.81	1.90	2.02	2.14	2.28	2.40	2.52	2.67	2.81	2.96
	Discrete Spd Setting		B	B	B	B	A	A	A	A	A	A	A	C	C	C	C	C
	RPM		588	630	670	710	750	780	815	845	880	910	945	975	1005	1035	1065	1095
6,000	BHP		1.25	1.40	1.51	1.61	1.73	1.84	1.94	2.05	2.18	2.30	2.42	2.54	2.67	2.79	2.94	3.08
	Discrete Spd Setting		B	B	B	A	A	A	A	A	A	A	A	C	C	C	C	C
	RPM		604	645	685	720	760	795	825	860	895	925	955	985	1015	1040	1070	1100
6,200	BHP		1.40	1.51	1.62	1.75	1.86	1.98	2.09	2.20	2.34	2.49	2.63	2.78	2.92	3.06	3.18	
	Discrete Spd Setting		B	B	B	A	A	A	A	A	A	A	C	C	C	C	C	
	RPM		625	660	695	735	770	805	840	875	905	935	965	995	1025	1055	1080	
6,400	BHP		1.55	1.68	1.79	1.90	2.04	2.18	2.32	2.44	2.56	2.68	2.80	2.92	3.07	3.19	3.33	
	Discrete Spd Setting		B	B	B	A	A	A	A	A	A	A	C	C	C	C	C	
	RPM		640	680	715	750	785	820	855	885	915	945	975	1005	1035	1060	1090	
6,600	BHP		1.73	1.84	1.94	2.06	2.20	2.34	2.46	2.58	2.70	2.82	2.94	3.07	3.19	3.34	3.46	
	Discrete Spd Setting		B	B	A	A	A	A	A	A	A	A	C	C	C	C	C	
	RPM		665	700	730	765	800	835	865	895	925	955	985	1015	1040	1070	1095	
6,800	BHP		1.87	1.98	2.08	2.20	2.34	2.48	2.62	2.74	2.86	2.96	3.08	3.24	3.38	3.55		
	Discrete Spd Setting		B	B	A	A	A	A	A	A	A	C	C	C	C	C		
	RPM		685	715	745	775	810	845	880	910	940	965	995	1025	1050	1080		
7,000	BHP		2.03	2.13	2.22	2.36	2.50	2.62	2.76	2.88	3.00	3.12	3.22	3.37	3.49	3.61		
	Discrete Spd Setting		B	A	A	A	A	A	A	A	A	C	C	C	C	C		
	RPM		705	730	755	790	825	855	890	920	950	980	1005	1035	1060	1085		

Notes:

- Motor Sheave set to 1-turn open from factory.
- Factory torque setting is A. Torque setting is field-adjustable to any torque setting listed in drive table through the ACU01 Service Tool.
- The unit can control the blower through LAT control. Enable this settings in the field with the ACU01 Service Tool.
- You can purchase the Advanced control panel as an accessory.
- The maximum allowable altitude of installation for this product is 6,561 ft (2,000 m).

Models:
SB
072-300

Blower Performance

SB192

SCFM	ESP (in.w.c.)	0.00	0.10	0.20	0.30	0.40	0.50	0.60	0.70	0.80	0.90	1.00	1.10	1.20	1.30	1.40	1.50
4,800	BHP		0.98	1.07	1.16	1.24	1.34	1.47	1.59	1.69	1.78	1.87	1.96	2.06	2.18	2.30	2.42
	Sheave/Mtr		B	B	B	B	A	A	A	A	A	A	A	C	C	C	C
	RPM		615	660	700	740	775	815	855	890	920	955	985	1015	1045	1075	1105
5,000	BHP	0.99	1.07	1.18	1.27	1.37	1.49	1.60	1.73	1.82	1.92	2.00	2.10	2.22	2.32	2.44	2.56
	Sheave/Mtr	B	B	B	B	A	A	A	A	A	A	A	A	C	C	C	C
	RPM	594	635	680	720	760	795	830	870	900	935	965	1000	1030	1055	1085	1115
5,200	BHP	1.09	1.18	1.28	1.36	1.48	1.59	1.70	1.82	1.93	2.02	2.14	2.24	2.36	2.48	2.60	2.72
	Sheave/Mtr	B	B	B	B	A	A	A	A	A	A	A	C	C	C	C	C
	RPM	620	660	700	735	775	810	845	880	915	945	980	1010	1040	1070	1100	1130
5,400	BHP	1.19	1.29	1.39	1.48	1.59	1.70	1.80	1.92	2.03	2.16	2.26	2.38	2.50	2.62	2.74	2.87
	Sheave/Mtr	B	B	B	A	A	A	A	A	A	A	A	C	C	C	C	C
	RPM	640	680	720	755	790	825	860	895	925	960	990	1020	1050	1080	1110	1140
5,600	BHP	1.30	1.40	1.51	1.62	1.74	1.85	1.95	2.08	2.18	2.31	2.42	2.57	2.71	2.86	2.98	3.12
	Sheave/Mtr	B	B	B	A	A	A	A	A	A	A	C	C	C	C	C	E
	RPM	660	700	740	775	810	845	875	910	940	975	1005	1035	1065	1095	1120	1150
5,800	BHP	1.41	1.52	1.63	1.73	1.84	1.95	2.06	2.18	2.32	2.44	2.57	2.72	2.86	3.00	3.15	3.27
	Sheave/Mtr	B	B	A	A	A	A	A	A	A	A	C	C	C	E	E	E
	RPM	680	720	760	790	825	860	890	920	955	985	1015	1045	1075	1105	1135	1160
6,000	BHP	1.56	1.67	1.78	1.89	2.00	2.12	2.24	2.36	2.48	2.60	2.74	2.89	3.01	3.15	3.30	3.42
	Sheave/Mtr	B	B	A	A	A	A	A	A	A	C	C	C	E	E	E	E
	RPM	700	740	775	810	845	880	910	940	970	1000	1030	1060	1085	1115	1145	1170
6,200	BHP	1.70	1.83	1.94	2.06	2.17	2.30	2.44	2.58	2.73	2.87	3.02	3.14	3.28	3.40	3.54	3.66
	Sheave/Mtr	B	A	A	A	A	A	A	A	A	C	E	E	E	E	E	E
	RPM	720	760	795	830	865	895	925	955	985	1015	1045	1070	1100	1125	1155	1180
6,400	BHP	1.88	2.02	2.16	2.28	2.42	2.54	2.66	2.78	2.90	3.04	3.16	3.31	3.43	3.58	3.72	3.86
	Sheave/Mtr	B	A	A	A	A	A	A	A	C	E	E	E	E	E	E	E
	RPM	745	780	815	845	880	910	940	970	1000	1030	1055	1085	1110	1140	1165	1190
6,600	BHP	2.06	2.18	2.32	2.46	2.58	2.70	2.82	2.94	3.07	3.19	3.34	3.46	3.60	3.74	3.88	4.02
	Sheave/Mtr	A	A	A	A	A	A	A	A	E	E	E	E	E	E	E	E
	RPM	765	795	830	865	895	925	955	985	1015	1040	1070	1095	1125	1150	1175	1200
6,800	BHP	2.22	2.36	2.50	2.62	2.74	2.86	3.00	3.10	3.27	3.41	3.58	3.72	3.85	3.97	4.11	4.23
	Sheave/Mtr	A	A	A	A	A	A	D	D	E	E	E	E	E	E	E	E
	RPM	780	815	850	880	910	940	970	1000	1030	1055	1085	1110	1135	1160	1190	1215

Notes:

- A, 1 = Standard RPM/Standard Blower Motor
- E, 5 = High RPM/Large Blower Motor
- The maximum allowable altitude of installation for this product is 6,561 ft (2,000 m).

Table continued on next page.

Blower Performance SB192

Models:
SB
072-300

Table continued from previous page.

SCFM	ESP (in.w.c.)	0.00	0.10	0.20	0.30	0.40	0.50	0.60	0.70	0.80	0.90	1.00	1.10	1.20	1.30	1.40	1.50	
7,000	BHP	2.40	2.54	2.66	2.80	2.92	3.04	3.14	3.27	3.39	3.54	3.66	3.78	3.96	4.12	4.28	4.44	
	Sheave/Mtr	A	A	A	A	A	D	D	E	E	E	E	E	E	E	E	E	
	RPM	800	835	865	900	930	960	985	1015	1040	1070	1095	1120	1150	1175	1200	1225	
7,200	BHP	2.58	2.70	2.85	2.99	3.14	3.28	3.42	3.54	3.66	3.81	3.93	4.06	4.22	4.38	4.54	4.70	
	Sheave/Mtr	A	A	A	A	D	D	E	E	E	E	E	E	E	E	E	E	
	RPM	820	850	885	915	945	975	1005	1030	1055	1085	1110	1135	1160	1185	1210	1235	
7,400	BHP	2.76	2.88	3.02	3.16	3.31	3.45	3.61	3.75	3.92	4.06	4.20	4.36	4.52	4.68	4.81	4.97	
	Sheave/Mtr	A	A	D	D	D	D	E	E	E	E	E	E	E	E	E	E	
	RPM	840	870	900	930	960	990	1020	1045	1075	1100	1125	1150	1175	1200	1220	1245	
7,600	BHP	2.94	3.07	3.22	3.36	3.50	3.63	3.82	3.98	4.14	4.34	4.50	4.66	4.78	4.94			
	Sheave/Mtr	A	D	D	D	D	E	E	E	E	E	E	E	E	E			
	RPM	860	890	920	950	980	1005	1035	1060	1085	1115	1140	1165	1185	1210			
7,800	BHP	3.22	3.34	3.49	3.63	3.78	3.96	4.12	4.28	4.44	4.63	4.76	4.92					
	Sheave/Mtr	D	D	D	D	D	E	E	E	E	E	E	E					
	RPM	880	905	935	965	995	1025	1050	1075	1100	1130	1150	1175					
8,000	BHP	3.41	3.58	3.75	3.92	4.06	4.26	4.42	4.58	4.74	4.90							
	Sheave/Mtr	D	D	D	D	E	E	E	E	E	E							
	RPM	895	925	955	985	1010	1040	1065	1090	1115	1140							

- Notes:
- A, I = Standard RPM/Standard Blower Motor
 - E, S = High RPM/Large Blower Motor
 - The maximum allowable altitude of installation for this product is 6,561 ft (2,000 m).

Models:
SB
072-300

Blower Performance SB192 with VFD

SCFM	ESP (in.w.c.)	0.00	0.10	0.20	0.30	0.40	0.50	0.60	0.70	0.80	0.90	1.00	1.10	1.20	1.30	1.40	1.50
4,800	BHP		0.98	1.07	1.16	1.24	1.34	1.47	1.59	1.69	1.78	1.87	1.96	2.06	2.18	2.30	2.42
	Discrete Spd Setting		B	B	B	B	A	A	A	A	A	A	A	C	C	C	C
	RPM		615	660	700	740	775	815	855	890	920	955	985	1015	1045	1075	1105
5,000	BHP	0.99	1.07	1.18	1.27	1.37	1.49	1.60	1.73	1.82	1.92	2.00	2.10	2.22	2.32	2.44	2.56
	Discrete Spd Setting	B	B	B	B	A	A	A	A	A	A	A	A	C	C	C	C
	RPM	594	635	680	720	760	795	830	870	900	935	965	1000	1030	1055	1085	1115
5,200	BHP	1.09	1.18	1.28	1.36	1.48	1.59	1.70	1.82	1.93	2.02	2.14	2.24	2.36	2.48	2.60	2.72
	Sheave/Mtr	B	B	B	B	A	A	A	A	A	A	A	C	C	C	C	C
	RPM	620	660	700	735	775	810	845	880	915	945	980	1010	1040	1070	1100	1130
5,400	BHP	1.19	1.29	1.39	1.48	1.59	1.70	1.80	1.92	2.03	2.16	2.26	2.38	2.50	2.62	2.74	2.87
	Discrete Spd Setting	B	B	B	A	A	A	A	A	A	A	A	C	C	C	C	C
	RPM	640	680	720	755	790	825	860	895	925	960	990	1020	1050	1080	1110	1140
5,600	BHP	1.30	1.40	1.51	1.62	1.74	1.85	1.95	2.08	2.18	2.31	2.42	2.57	2.71	2.86	2.98	3.12
	Sheave/Mtr	B	B	B	A	A	A	A	A	A	A	C	C	C	C	C	C
	RPM	660	700	740	775	810	845	875	910	940	975	1005	1035	1065	1095	1120	1150
5,800	BHP	1.41	1.52	1.63	1.73	1.84	1.95	2.06	2.18	2.32	2.44	2.57	2.72	2.86	3.00	3.15	3.27
	Discrete Spd Setting	B	B	A	A	A	A	A	A	A	A	C	C	C	C	C	C
	RPM	680	720	760	790	825	860	890	920	955	985	1015	1045	1075	1105	1135	1160
6,000	BHP	1.56	1.67	1.78	1.89	2.00	2.12	2.24	2.36	2.48	2.60	2.74	2.89	3.01	3.15	3.30	3.42
	Discrete Spd Setting	B	B	A	A	A	A	A	A	A	C	C	C	C	C	C	C
	RPM	700	740	775	810	845	880	910	940	970	1000	1030	1060	1085	1115	1145	1170
6,200	BHP	1.70	1.83	1.94	2.06	2.17	2.30	2.44	2.58	2.73	2.87	3.02	3.14	3.28	3.40	3.54	3.66
	Discrete Spd Setting	B	A	A	A	A	A	A	A	A	C	C	C	C	C	C	C
	RPM	720	760	795	830	865	895	925	955	985	1015	1045	1070	1100	1125	1155	1180
6,400	BHP	1.88	2.02	2.16	2.28	2.42	2.54	2.66	2.78	2.90	3.04	3.16	3.31	3.43	3.58	3.72	3.86
	Discrete Spd Setting	B	A	A	A	A	A	A	A	C	C	C	C	C	C	C	C
	RPM	745	780	815	845	880	910	940	970	1000	1030	1055	1085	1110	1140	1165	1190
6,600	BHP	2.06	2.18	2.32	2.46	2.58	2.70	2.82	2.94	3.07	3.19	3.34	3.46	3.60	3.74	3.88	4.02
	Discrete Spd Setting	A	A	A	A	A	A	A	A	C	C	C	C	C	C	C	C
	RPM	765	795	830	865	895	925	955	985	1015	1040	1070	1095	1125	1150	1175	1200
6,800	BHP	2.22	2.36	2.50	2.62	2.74	2.86	3.00	3.10	3.27	3.41	3.58	3.72	3.85	3.97	4.11	4.23
	Discrete Spd Setting	A	A	A	A	A	A	A	A	C	C	C	C	C	C	C	C
	RPM	780	815	850	880	910	940	970	1000	1030	1055	1085	1110	1135	1160	1190	1215

Notes:

- Motor Sheave set to 1-turn open from factory.
- Factory torque setting is A. Torque setting is field-adjustable to any torque setting listed in drive table through the ACDU01 Service Tool.
- The unit can control the blower through LAT control. Enable this settings in the field with the ACDU01 Service Tool.
- You can purchase the Advanced control panel as an accessory.
- The maximum allowable altitude of installation for this product is 6,561 ft (2,000 m).

Table continued on next page.

Blower Performance SB192 with VFD

Models:
SB
072-300

Table continued from previous page.

SCFM	ESP (in.w.c.)	0.00	0.10	0.20	0.30	0.40	0.50	0.60	0.70	0.80	0.90	1.00	1.10	1.20	1.30	1.40	1.50
7,000	BHP	2.40	2.54	2.66	2.80	2.92	3.04	3.14	3.27	3.39	3.54	3.66	3.78	3.96	4.12	4.28	4.44
	Discrete Spd Setting	A	A	A	A	A	A	A	C	C	C	C	C	C	C	C	C
	RPM	800	835	865	900	930	960	985	1015	1040	1070	1095	1120	1150	1175	1200	1225
7,200	BHP	2.58	2.70	2.85	2.99	3.14	3.28	3.42	3.54	3.66	3.81	3.93	4.06	4.22	4.38	4.54	4.70
	Discrete Spd Setting	A	A	A	A	A	A	C	C	C	C	C	C	C	C	C	C
	RPM	820	850	885	915	945	975	1005	1030	1055	1085	1110	1135	1160	1185	1210	1235
7,400	BHP	2.76	2.88	3.02	3.16	3.31	3.45	3.61	3.75	3.92	4.06	4.20	4.36	4.52	4.68	4.81	4.97
	Discrete Spd Setting	A	A	A	A	A	A	C	C	C	C	C	C	C	C	C	C
	RPM	840	870	900	930	960	990	1020	1045	1075	1100	1125	1150	1175	1200	1220	1245
7,600	BHP	2.94	3.07	3.22	3.36	3.50	3.63	3.82	3.98	4.14	4.34	4.50	4.66	4.78	4.94		
	Discrete Spd Setting	A	D	D	D	D	C	C	C	C	C	C	C	C	C		
	RPM	860	890	920	950	980	1005	1035	1060	1085	1115	1140	1165	1185	1210		
7,800	BHP	3.22	3.34	3.49	3.63	3.78	3.96	4.12	4.28	4.44	4.63	4.76	4.92				
	Discrete Spd Setting	A	A	A	A	A	C	C	C	C	C	C	C				
	RPM	880	905	935	965	995	1025	1050	1075	1100	1130	1150	1175				
8,000	BHP	3.41	3.58	3.75	3.92	4.06	4.26	4.42	4.58	4.74	4.90						
	Discrete Spd Setting	A	A	A	A	C	C	C	C	C	C						
	RPM	895	925	955	985	1010	1040	1065	1090	1115	1140						

Notes:

- Motor Sheave set to 1-turn open from factory.
- Factory torque setting is A. Torque setting is field-adjustable to any torque setting listed in drive table through the ACDU01 Service Tool.
- The unit can control the blower through LAT control. Enable this settings in the field with the ACDU01 Service Tool.
- You can purchase the Advanced control panel as an accessory.
- The maximum allowable altitude of installation for this product is 6,561 ft (2,000 m).

Models:
SB
072-300

Blower Performance

SB240

SCFM	ESP (in.w.c.)	0.00	0.10	0.20	0.30	0.40	0.50	0.60	0.70	0.80	0.90	1.00	1.10	1.20	1.30	1.40	1.50
6,000	BHP				1.78	1.89	2.00	2.12	2.24	2.36	2.48	2.60	2.74	2.89	3.01	3.15	3.30
	Sheave/Mtr				B	B	B	A	A	A	A	A	A	A	A	C	C
	RPM				775	810	845	880	910	940	970	1000	1030	1060	1085	1115	1145
6,200	BHP			1.82	1.93	2.04	2.15	2.30	2.44	2.58	2.73	2.87	2.99	3.14	3.26	3.40	3.52
	Sheave/Mtr			B	B	B	B	A	A	A	A	A	A	A	C	C	C
	RPM			755	790	825	860	895	925	955	985	1015	1040	1070	1095	1125	1150
6,400	BHP			2.00	2.14	2.26	2.40	2.52	2.64	2.76	2.88	3.02	3.14	3.28	3.40	3.56	3.70
	Sheave/Mtr			B	B	B	B	A	A	A	A	A	A	A	C	C	C
	RPM			775	810	840	875	905	935	965	995	1025	1050	1080	1105	1135	1160
6,600	BHP		2.02	2.16	2.30	2.42	2.56	2.68	2.80	2.92	3.05	3.17	3.29	3.43	3.55	3.71	3.85
	Sheave/Mtr		B	B	B	B	A	A	A	A	A	A	A	A	C	C	C
	RPM		755	790	825	855	890	920	950	980	1010	1035	1060	1090	1115	1145	1170
6,800	BHP		2.18	2.32	2.46	2.58	2.70	2.84	2.94	3.06	3.21	3.35	3.52	3.66	3.82	3.94	4.06
	Sheave/Mtr		B	B	B	B	A	A	A	A	A	A	A	C	C	C	C
	RPM		770	805	840	870	900	935	960	990	1020	1045	1075	1100	1130	1155	1180
7,000	BHP	2.22	2.34	2.48	2.62	2.74	2.86	2.98	3.10	3.22	3.34	3.49	3.61	3.73	3.90	4.06	4.22
	Sheave/Mtr	B	B	B	B	A	A	A	A	A	A	A	A	C	C	C	C
	RPM	755	785	820	855	885	915	945	975	1005	1030	1060	1085	1110	1140	1165	1190
7,200	BHP	2.38	2.52	2.64	2.78	2.92	3.06	3.21	3.35	3.47	3.62	3.74	3.88	4.00	4.16	4.32	4.48
	Sheave/Mtr	B	B	B	B	A	A	A	A	A	A	A	C	C	C	C	C
	RPM	770	805	835	870	900	930	960	990	1015	1045	1070	1100	1125	1150	1175	1200
7,400	BHP	2.56	2.68	2.82	2.95	3.09	3.24	3.38	3.53	3.67	3.84	3.98	4.12	4.26	4.42	4.58	4.74
	Sheave/Mtr	B	B	B	A	A	A	A	A	A	A	A	C	C	C	C	C
	RPM	790	820	855	885	915	945	975	1005	1030	1060	1085	1110	1135	1160	1185	1210
7,600	BHP	2.74	2.86	2.98	3.12	3.26	3.41	3.55	3.70	3.89	4.05	4.21	4.40	4.53	4.69	4.85	
	Sheave/Mtr	B	B	B	A	A	A	A	A	A	A	C	C	C	C	C	
	RPM	810	840	870	900	930	960	990	1015	1045	1070	1095	1125	1145	1170	1195	
7,800	BHP	2.98	3.13	3.25	3.39	3.54	3.68	3.83	3.99	4.15	4.34	4.50	4.66	4.82	4.95		
	Sheave/Mtr	B	B	A	A	A	A	A	A	A	C	C	C	C	C		
	RPM	830	860	885	915	945	975	1005	1030	1055	1085	1110	1135	1160	1180		
8,000	BHP	3.18	3.30	3.44	3.61	3.78	3.94	4.10	4.29	4.45	4.61	4.77	4.93				
	Sheave/Mtr	B	B	A	A	A	A	A	A	A	C	C	C				
	RPM	850	875	900	930	960	990	1015	1045	1070	1095	1120	1145				

- Notes:
- A, 1 = Standard RPM/Standard Blower Motor
 - E, 5 = High RPM/Large Blower Motor
 - The maximum allowable altitude of installation for this product is 6,561 ft (2,000 m).

Table continued on next page.

Blower Performance SB240

Models:
SB
072-300

Table continued from previous page.

SCFM	ESP (in.w.c.)	0.00	0.10	0.20	0.30	0.40	0.50	0.60	0.70	0.80	0.90	1.00	1.10	1.20	1.30	1.40	1.50	
8,200	BHP	3.35	3.48	3.65	3.79	3.96	4.13	4.27	4.44	4.58	4.72	4.88						
	Sheave/Mtr	B	A	A	A	A	A	A	A	A	C	C						
	RPM	865	890	920	945	975	1005	1030	1060	1085	1110	1135						
8,400	BHP	3.62	3.74	3.89	4.03	4.18	4.33	4.49	4.65	4.81	4.97							
	Sheave/Mtr	A	A	A	A	A	A	A	A	C	C							
	RPM	880	905	935	965	995	1020	1045	1070	1095	1120							
8,600	BHP	3.81	3.98	4.12	4.29	4.46	4.62	4.78	4.94									
	Sheave/Mtr	A	A	A	A	A	A	A	A									
	RPM	895	925	950	980	1010	1035	1060	1085									
8,800	BHP	4.06	4.22	4.41	4.57	4.73	4.92											
	Sheave/Mtr	A	A	A	A	A	A											
	RPM	915	940	970	995	1020	1050											
9,000	BHP	4.38	4.54	4.70	4.86													
	Sheave/Mtr	A	A	A	A													
	RPM	935	960	985	1010													
9,200	BHP	4.65	4.76	4.90														
	Sheave/Mtr	A	A	A														
	RPM	955	975	1000														
9,400	BHP	4.83	4.94															
	Sheave/Mtr	A	A															
	RPM	970	990															
9,600	BHP																	
	Sheave/Mtr																	
	RPM																	

- Notes:
- A, 1 = Standard RPM/Standard Blower Motor
 - E, 5 = High RPM/Large Blower Motor
 - The maximum allowable altitude of installation for this product is 6,561 ft (2,000 m).

Models:
SB
072-300

Blower Performance SB240 with VFD

SCFM	ESP (in.w.c.)	0.00	0.10	0.20	0.30	0.40	0.50	0.60	0.70	0.80	0.90	1.00	1.10	1.20	1.30	1.40	1.50		
6,000	BHP				1.78	1.89	2.00	2.12	2.24	2.36	2.48	2.60	2.74	2.89	3.01	3.15	3.30		
	Discrete Spd Setting				B	B	B	A	A	A	A	A	A	A	A	C	C		
	RPM				775	810	845	880	910	940	970	1000	1030	1060	1085	1115	1145		
6,200	BHP			1.82	1.93	2.04	2.15	2.30	2.44	2.58	2.73	2.87	2.99	3.14	3.26	3.40	3.52		
	Discrete Spd Setting				B	B	B	B	A	A	A	A	A	A	A	C	C	C	
	RPM				755	790	825	860	895	925	955	985	1015	1040	1070	1095	1125	1150	
6,400	BHP			2.00	2.14	2.26	2.40	2.52	2.64	2.76	2.88	3.02	3.14	3.28	3.40	3.56	3.70		
	Discrete Spd Setting				B	B	B	B	A	A	A	A	A	A	A	C	C	C	
	RPM				775	810	840	875	905	935	965	995	1025	1050	1080	1105	1135	1160	
6,600	BHP		2.02	2.16	2.30	2.42	2.56	2.68	2.80	2.92	3.05	3.17	3.29	3.43	3.55	3.71	3.85		
	Discrete Spd Setting				B	B	B	B	A	A	A	A	A	A	A	C	C	C	
	RPM				755	790	825	855	890	920	950	980	1010	1035	1060	1090	1115	1145	1170
6,800	BHP		2.18	2.32	2.46	2.58	2.70	2.84	2.94	3.06	3.21	3.35	3.52	3.66	3.82	3.94	4.06		
	Discrete Spd Setting				B	B	B	B	A	A	A	A	A	A	C	C	C	C	
	RPM				770	805	840	870	900	935	960	990	1020	1045	1075	1100	1130	1155	1180
7,000	BHP	2.22	2.34	2.48	2.62	2.74	2.86	2.98	3.10	3.22	3.34	3.49	3.61	3.73	3.90	4.06	4.22		
	Discrete Spd Setting				B	B	B	B	A	A	A	A	A	A	C	C	C	C	
	RPM				755	785	820	855	885	915	945	975	1005	1030	1060	1085	1110	1140	1165
7,200	BHP	2.38	2.52	2.64	2.78	2.92	3.06	3.21	3.35	3.47	3.62	3.74	3.88	4.00	4.16	4.32	4.48		
	Discrete Spd Setting				B	B	B	B	A	A	A	A	A	C	C	C	C	C	
	RPM				770	805	835	870	900	930	960	990	1015	1045	1070	1100	1125	1150	1175
7,400	BHP	2.56	2.68	2.82	2.95	3.09	3.24	3.38	3.53	3.67	3.84	3.98	4.12	4.26	4.42	4.58	4.74		
	Discrete Spd Setting				B	B	B	A	A	A	A	A	A	C	C	C	C	C	
	RPM				790	820	855	885	915	945	975	1005	1030	1060	1085	1110	1135	1160	1185
7,600	BHP	2.74	2.86	2.98	3.12	3.26	3.41	3.55	3.70	3.89	4.05	4.21	4.40	4.53	4.69	4.85	5.01		
	Discrete Spd Setting				B	B	B	A	A	A	A	A	C	C	C	C	C	C	
	RPM				810	840	870	900	930	960	990	1015	1045	1070	1095	1125	1145	1170	1195
7,800	BHP	2.98	3.13	3.25	3.39	3.54	3.68	3.83	3.99	4.15	4.34	4.50	4.66	4.82	4.95	5.11	5.27		
	Discrete Spd Setting				B	B	A	A	A	A	A	C	C	C	C	C	C	C	
	RPM				830	860	885	915	945	975	1005	1030	1055	1085	1110	1135	1160	1180	1205
8,000	BHP	3.18	3.30	3.44	3.61	3.78	3.94	4.10	4.29	4.45	4.61	4.77	4.93	5.09	5.25	5.38	5.54		
	Discrete Spd Setting				B	B	A	A	A	A	A	C	C	C	C	C	C	C	
	RPM				850	875	900	930	960	990	1015	1045	1070	1095	1120	1145	1170	1195	1215

Notes:

- Motor Sheave set to 1-turn open from factory.
- Factory torque setting is A. Torque setting is field-adjustable to any torque setting listed in drive table through the ACDU01 Service Tool.
- The unit can control the blower through LAT control. Enable this settings in the field with the ACDU01 Service Tool.
- You can purchase the Advanced control panel as an accessory.
- The maximum allowable altitude of installation for this product is 6,561 ft (2,000 m).

Table continued on next page.

Blower Performance SB240 with VFD

Models:
SB
072-300

Table continued from previous page.

SCFM	ESP (in.w.c.)	0.00	0.10	0.20	0.30	0.40	0.50	0.60	0.70	0.80	0.90	1.00	1.10	1.20	1.30	1.40	1.50
8,200	BHP	3.35	3.48	3.65	3.79	3.96	4.13	4.27	4.44	4.58	4.72	4.88	5.08	5.24	5.44	5.64	
	Discrete Spd Setting	B	A	A	A	A	A	A	A	A	C	C	C	C	C	C	
	RPM	865	890	920	945	975	1005	1030	1060	1085	1110	1135	1160	1180	1205	1230	
8,400	BHP	3.62	3.74	3.89	4.03	4.18	4.33	4.49	4.65	4.81	4.97	5.16	5.36	5.56	5.72	5.92	
	Discrete Spd Setting	A	A	A	A	A	A	A	A	C	C	C	C	C	C	C	
	RPM	880	905	935	965	995	1020	1045	1070	1095	1120	1145	1170	1195	1215	1240	
8,600	BHP	3.81	3.98	4.12	4.29	4.46	4.62	4.78	4.94	5.10	5.28	5.48	5.64	5.84	6.04	6.20	
	Discrete Spd Setting	A	A	A	A	A	A	A	A	C	C	C	C	C	C	C	
	RPM	895	925	950	980	1010	1035	1060	1085	1110	1135	1160	1180	1205	1230	1250	
8,800	BHP	4.06	4.22	4.41	4.57	4.73	4.92	5.08	5.24	5.40	5.60	5.76	5.96	6.16	6.32		
	Discrete Spd Setting	A	A	A	A	A	A	A	C	C	C	C	C	C	C		
	RPM	915	940	970	995	1020	1050	1075	1100	1125	1150	1170	1195	1220	1240		
9,000	BHP	4.38	4.54	4.70	4.86	5.02	5.18	5.34	5.50	5.68	5.88	6.08	6.24				
	Sheave/Mtr	A	A	A	A	A	A	A	C	C	C	C	C				
	RPM	935	960	985	1010	1035	1060	1085	1110	1135	1160	1185	1205				
	Turns Open	4.5	4	3.5	3	2	1.5	1	3.5	3	2.5	2	1.5				
9,200	BHP	4.65	4.76	4.90	5.08	5.26	5.44	5.62	5.80	6.00	6.16						
	Discrete Spd Setting	A	A	A	A	A	A	C	C	C	C						
	RPM	955	975	1000	1025	1050	1075	1100	1125	1150	1170						
9,400	BHP	4.83	4.94	5.12	5.32	5.52	5.72	5.92	6.12	6.32	6.48						
	Discrete Spd Setting	A	A	A	A	A	A	C	C	C	C						
	RPM	970	990	1015	1040	1065	1090	1115	1140	1165	1185						
9,600	BHP	5.10	5.24	5.44	5.64	5.84	6.04	6.24	6.40								
	Discrete Spd Setting	A	A	A	A	A	C	C	C								
	RPM	985	1005	1030	1055	1080	1105	1130	1150								

- Notes:
- Motor Sheave set to 1-turn open from factory.
 - Factory torque setting is A. Torque setting is field-adjustable to any torque setting listed in drive table through the ACDU01 Service Tool.
 - The unit can control the blower through LAT control. Enable this settings in the field with the ACDU01 Service Tool.
 - You can purchase the Advanced control panel as an accessory.
 - The maximum allowable altitude of installation for this product is 6,561 ft (2,000 m).

Models:
SB
072-300

Blower Performance SB300 with VFD

SCFM	ESP (in.w.c.)	0.00	0.10	0.20	0.30	0.40	0.50	0.60	0.70	0.80	0.90	1.00	1.10	1.20	1.30	1.40	1.50
7,500	BHP	2.69	2.84	2.96	3.11	3.27	3.45	3.60	3.78	3.96	4.08	4.23	4.38	4.53	4.69	4.86	5.03
	Discrete Spd Setting	B	B	B	B	A	A	A	A	A	A	A	A	A	C	C	C
	RPM	890	925	955	990	1020	1050	1075	1105	1135	1155	1180	1205	1230	1255	1275	1295
7,800	BHP	2.87	3.04	3.18	3.36	3.54	3.72	3.87	4.05	4.20	4.35	4.50	4.65	4.80	4.97	5.14	5.30
	Discrete Spd Setting	B	B	B	A	A	A	A	A	A	A	A	A	C	C	C	C
	RPM	910	945	975	1010	1040	1070	1095	1125	1150	1175	1200	1225	1250	1270	1290	1310
8,100	BHP	3.10	3.26	3.42	3.60	3.78	3.96	4.14	4.34	4.52	4.70	4.88	5.06	5.21	5.35	5.53	5.68
	Discrete Spd Setting	B	B	B	A	A	A	A	A	A	A	A	C	C	C	C	C
	RPM	935	965	995	1025	1055	1085	1115	1145	1170	1195	1220	1245	1265	1285	1310	1330
8,400	BHP	3.36	3.52	3.74	3.92	4.14	4.36	4.57	4.75	4.93	5.11	5.29	5.47	5.62	5.80	5.94	6.12
	Discrete Spd Setting	B	B	A	A	A	A	A	A	A	A	A	C	C	C	C	C
	RPM	955	985	1020	1045	1075	1105	1135	1160	1185	1210	1235	1260	1280	1305	1325	1350
8,700	BHP	3.60	3.79	4.00	4.22	4.43	4.65	4.83	5.01	5.19	5.37	5.55	5.76	5.97	6.14	6.35	6.56
	Discrete Spd Setting	B	A	A	A	A	A	A	A	A	A	C	C	C	C	C	C
	RPM	975	1005	1035	1065	1095	1125	1150	1175	1200	1225	1250	1275	1300	1320	1345	1370
9,000	BHP	3.90	4.12	4.30	4.51	4.73	4.91	5.09	5.30	5.48	5.66	5.89	6.08	6.32	6.56	6.76	
	Discrete Spd Setting	A	A	A	A	A	A	A	A	A	C	C	C	C	C	C	
	RPM	1000	1030	1055	1085	1115	1140	1165	1195	1220	1245	1270	1290	1315	1340	1360	
9,300	BHP	4.34	4.56	4.74	4.96	5.14	5.35	5.53	5.71	5.89	6.08	6.29	6.50	6.67	6.88	7.05	
	Discrete Spd Setting	A	A	A	A	A	A	A	A	A	C	C	C	C	C	C	
	RPM	1020	1050	1075	1105	1130	1160	1185	1210	1235	1260	1285	1310	1330	1355	1375	
9,600	BHP	4.64	4.85	5.03	5.25	5.46	5.67	5.88	6.13	6.34	6.52	6.66	6.84	7.02	7.16		
	Discrete Spd Setting	A	A	A	A	A	A	A	A	C	C	C	C	C	C		
	RPM	1040	1070	1095	1125	1150	1175	1200	1230	1255	1280	1300	1325	1350	1370		
9,900	BHP	4.93	5.15	5.33	5.53	5.78	5.99	6.20	6.41	6.62	6.83	7.04	7.21	7.42			
	Discrete Spd Setting	A	A	A	A	A	A	A	C	C	C	C	C	C			
	RPM	1060	1090	1115	1140	1170	1195	1220	1245	1270	1295	1320	1340	1365			
10,200	BHP	5.36	5.57	5.77	5.95	6.17	6.35	6.53	6.74	6.94	7.18						
	Discrete Spd Setting	A	A	A	A	A	A	C	C	C	C						
	RPM	1085	1110	1135	1160	1190	1215	1240	1265	1285	1310						
10,500	BHP	5.52	5.75	5.99	6.23	6.47	6.71	6.95	7.19								
	Discrete Spd Setting	A	A	A	A	A	A	C	C								
	RPM	1100	1130	1155	1180	1205	1230	1255	1280								
10,800	BHP	6.00	6.24	6.48	6.72	6.96	7.20	7.39	7.63								
	Discrete Spd Setting	A	A	A	A	A	C	C	C								
	RPM	1125	1150	1175	1200	1225	1250	1270	1295								

Notes:

- Motor Sheave set to 1-turn open from factory.
- Factory torque setting is A. Torque setting is field-adjustable to any torque setting listed in drive table through the ACDU01 Service Tool.
- The unit can control the blower through LAT control. Enable this settings in the field with the ACDU01 Service Tool.
- You can purchase the Advanced control panel as an accessory.
- The maximum allowable altitude of installation for this product is 6,561 ft (2,000 m).

Operating Limits and Commissioning Conditions

OPERATING LIMITS

Environment – Units are designed for indoor installation only. Never install units in areas subject to freezing or where humidity levels could cause cabinet condensation (such as unconditioned spaces subject to 100% outside air).

Power Supply – Voltage utilization shall comply with AHRI Standard 110 or values provided in the electrical data tables.

Determination of operating limits is dependent primarily upon three factors: 1) return air temperature. 2) water temperature, and 3) ambient temperature. When any one of these factors is at minimum or maximum levels, the other two factors should be at normal levels to ensure proper unit operation. Extreme variations in temperature and humidity and/or corrosive water or air will adversely affect unit performance, reliability, and service life.

Table 8: Operating Limits

Operating Limits	Cooling	Heating
Air Limits		
Min. ambient air, DB ^{1 3}	10°F [-12°C]	10°F [-12°C]
Max. ambient air, DB ³	130°F [54.4°C]	130°F [54.4°C]
Min. entering air, DB/WB	60/50°F [16/10°C]	50°F [10°C]
Max. entering air, DB/WB	90/73°F [32/23°C]	80°F [27°C]
Min/Max Airflow (CFM/Ton) ²	300 to 500 CFM/Ton	
Water Limits		
Min. entering water (072-120) ¹	30°F [-1°C]	20°F [-6.7°C]
Min. entering water (168-300) ¹	30°F [-1°C]	30°F [-1°C]
Operating range	50-110°F [10-43°C]	30-70°F [-1 to 21°C]
Max. entering water	120°F [49°C]	90°F [32°C]
Water Flow Range ³	1.5 to 3.0 gpm/ton [1.6 to 3.2 l/m per kW]	

- Notes:
- Circulating fluid shall be protected to ensure that freezing will not occur when not in operation.
 - All information is provided at rated cfm (400cfm/ton).
 - For units equipped with flow-control automation, cooling & heating min/max ambient temps are 15°F (-9°C) / 120°F (49°C).

Unit Maximum Water Working Pressure

Configuration	Max Pressure PSIG [kPa]
Base Unit	300 [2,068]
MWV	200 [1,379]
MOD Valve	200 [1,379]

Use the lowest maximum pressure rating when multiple options are combined.

COMMISSIONING CONDITIONS

Starting conditions vary depending upon model and are based upon the following notes:

NOTES:

- Commissioning Conditions are not normal or continuous operating conditions. Minimum/maximum limits are startup conditions to bring the building space up to occupancy temperatures. Units are not designed to operate under these conditions on a regular basis.
- Voltage utilization range complies with AHRI Standard 110.

Table 9: Commissioning Conditions

Commissioning Conditions	Cooling	Heating
Air Limits		
Min. ambient air, DB ^{1 3}	10°F [-12°C]	10°F [-12°C]
Max. ambient air, DB ³	130°F [54°C]	130°F [54°C]
Min. entering air, DB/WB	60/50°F [16/10°C]	**50°F [10°C]
Max. entering air, DB/WB	*90/73°F [32/23°C]	80°F [27°C]
Min/Max Airflow (CFM/Ton) ²	300 to 500 CFM/Ton	
Water Limits		
Min. entering water (072-120) ¹	30°F [-6.7°C]	20°F [-6.7°C]
Min. entering water (168-300) ¹	30°F [-1°C]	30°F [-1°C]
Operating range	50-110°F [10-43°C]	30-70°F [-1 to 21°C]
Max. entering water	120°F [49°C]	90°F [32°C]
Water Flow Range ³	1.5 to 3.0 gpm/ton [1.6 to 3.2 l/m per kW]	

- Notes:
- Circulating fluid shall be protected to ensure that freezing will not occur when not in operation.
 - All information is provided at rated cfm (400cfm/ton).
 - For units equipped with flow-control automation, cooling & heating min/max ambient temps are 15°F (-9°C) / 120°F (49°C).
- * Commission units for cooling at entering air temperatures of 100/75°F [38/24°C] only at rated water flow or 3 gpm/ton.
- ** Commission units for heating at entering air temperature of 40°F [4.4°C] only at rated water flow or 3 gpm/ton.

Models:
SB
072-300

Piping System Cleaning and Flushing

PIPING SYSTEM CLEANING AND FLUSHING

Cleaning and flushing the WLHP piping system is the single most important step to ensure proper startup and continued efficient operation of the system.

Follow the instructions below to properly clean and flush the system:

1. Ensure that electrical power to the unit is disconnected.
2. Install the system with the supply hose connected directly to the return riser valve. Use a single length of flexible hose.
3. Fill the system with water. DO NOT allow system to overflow. Bleed all air from the system. Pressurize and check the system for leaks and repair as appropriate. Models with Waterside Economizer also manually open economizer valve and coil air vents (2) to bleed air from coil.
4. Verify that all strainers are in place (ClimateMaster recommends a strainer with a #20 stainless steel wire mesh). Start the pumps, and systematically check each vent to ensure that all air is bled from the system.
5. Verify that make-up water is available. Adjust make-up water as required to replace the air which was bled from the system. Check and adjust the water/air level in the expansion tank.
6. Set the boiler to raise the loop temperature to approximately 86°F [30°C]. Open a drain at the lowest point in the system. Adjust the make-up water replacement rate to equal the rate of bleed.
7. Refill the system and add trisodium phosphate in a proportion of approximately one pound per 150 gallons (0.8 kg per 1000 l) of water (or other equivalent approved cleaning agent) Reset the boiler to raise the loop temperature to 100°F (38°C). Circulate the solution for a minimum of 8 to 24 hours. At the end of this period, shut off the circulating pump and drain the solution. Repeat system cleaning if desired.
8. When the cleaning process is complete, remove the short-circuited hoses. Reconnect the hoses to the proper supply, and return the connections to each of the units. Refill the system and bleed off all air.
9. Test the system pH with litmus paper. The system water should be in the range of pH 6.0 - 8.5 (see table 3). Add chemicals, as appropriate to maintain neutral pH levels.
10. When the system is successfully cleaned, flushed, refilled and bled, check the main system panels, safety cutouts and alarms. Set the controls to properly maintain loop temperatures.

CAUTION

DO NOT use "Stop Leak" or similar chemical agent in this system. Addition of chemicals of this type to the loop water will foul the heat exchanger and inhibit unit operation.

NOTE: The manufacturer strongly recommends all piping connections, both internal and external to the unit, be pressure tested by an appropriate method prior to any finishing of the interior space or before access to all connections is limited. Test pressure may not exceed the maximum allowable pressure for the unit and all components within the water system. The manufacturer will not be responsible or liable for damages from water leaks due to inadequate or lack of a pressurized leak test, or damages caused by exceeding the maximum pressure rating during installation.

WARNING

Polyester Oil, commonly known as POE oil, is a synthetic oil used in many refrigeration systems including those with R-454B refrigerant. POE oil, if it ever comes in contact with PVC or CPVC piping, may cause failure of the PVC/CPVC. PVC/CPVC piping should never be used as supply or return water piping with water source heat pump products containing R-454B as system failures and property damage may result.

Unit and System Checkout

UNIT CHECKOUT

BEFORE POWERING SYSTEM, please check the following:

- ❑ **Line voltage and wiring:** Verify that voltage is within an acceptable range for the unit and wiring and fuses/breakers are properly sized. Verify that low voltage wiring is complete.
- ❑ **Unit control transformer:** Ensure that transformer has the properly selected voltage tap. Commercial 380-420V units are factory wired for 380V operation unless specified otherwise.
- ❑ **Balancing/shutoff valves:** Ensure that all isolation valves are open (after system flushing - see System Checkout) and water control valves are wired.
- ❑ **Entering water and air:** Ensure that entering water and air temperatures are within operating limits of Table 8.
- ❑ **Low water temperature cutout:** Verify that low water temperature cut-out on the CXM2 is properly set.
- ❑ **Unit blower wheel:** Manually rotate blower wheel to verify free rotation and ensure that all blower wheels are secured to the blower motor shaft and centered in housing.
- ❑ **Blower motor:** Verify motor bolts are tight. DO NOT oil motors upon startup. Fan motors are pre-oiled at the factory.
- ❑ Ensure shaft pillow blocks, sheave, and pulley are tight
- ❑ **Sheave:** Verify sheave has been set to turns in design requirement. Record turns on start up log sheet.
- ❑ **Belt:** Verify belt is straight and proper tension
- ❑ **Condensate line:** Verify that condensate line is open, trapped, vented and properly pitched toward drain.
- ❑ **Water flow balancing:** Record inlet and outlet water temperatures for each heat pump upon startup. This check can eliminate nuisance trip outs and high velocity water flow that could erode heat exchangers.
- ❑ **Unit air coil and filters:** Ensure that filter is clean and accessible. Clean air coil of all manufacturing oils.
- ❑ **Unit controls:** Verify that CXM2 field-selection options are properly set.

SYSTEM CHECKOUT

- ❑ **System water temperature:** Check water temperature for proper range and also verify heating and cooling setpoints for proper operation.
- ❑ **System pH:** Check and adjust water pH if necessary to maintain a level between 6 and 8.5. Proper pH promotes longevity of hoses and fittings (see Table 3).
- ❑ **System flushing:** Verify that all hoses are connected end to end when flushing to ensure that debris bypasses the unit heat exchanger, water valves and other components. Water used in the system must be potable quality initially and clean of dirt, piping slag, and strong chemical cleaning agents. Verify that all air is purged from the system. Air in the system can cause poor operation or system corrosion.
- ❑ **Cooling tower/boiler:** Check equipment for proper setpoints and operation.
- ❑ **Standby pumps:** Verify that the standby pump is properly installed and in operating condition.
- ❑ **System controls:** Verify that system controls function and operate in the proper sequence.
- ❑ **Low water temperature cutout:** Verify that low water temperature cut-out controls are provided for the outdoor portion of the loop. Otherwise, operating problems may occur.
- ❑ **System control center:** Verify that the control center and alarm panel have appropriate setpoints and are operating as designed.
- ❑ **Miscellaneous:** Note any questionable aspects of the installation.

CAUTION

Verify that ALL water control valves are open and allow water flow prior to engaging the compressor. Freezing of the coax or water lines can permanently damage the heat pump.

CAUTION

To avoid equipment damage, DO NOT leave system filled in a building without heat during the winter unless antifreeze is added to the water loop. Heat exchangers never fully drain by themselves and will freeze unless winterized with antifreeze.

Models:
SB
072-300

Unit Startup Procedure

1. Turn the thermostat fan position to "ON". Blower should start.
2. Balance air flow at registers.
3. Adjust all valves to their full open positions. Turn on the line power to all heat pumps.
4. Room temperature should be within the minimum-maximum ranges of Table 8. During startup checks, loop water temperature entering the heat pump should be between 60°F (16°C) and 95°F (35°C).
5. Two factors determine the operating limits of ClimateMaster heat pumps, (a) return-air temperature, and (b) water temperature. When any one of these factors is at a minimum or maximum level, the other factor must be at normal level to ensure proper unit operation.

- a. Adjust the unit thermostat to the warmest setting. Place the thermostat mode switch in the "COOL" position. Slowly reduce thermostat setting until the compressor activates.
- b. Check for cool air delivery at the unit grille within a few minutes after the unit has begun to operate.

NOTE: Units have a five minute time delay in the control circuit that can be eliminated on the CXM2 Communicating Controls as shown in Figure 18. See controls description for details.

- c. Verify that the compressor is on and that the water flow rate is correct by measuring pressure drop through the heat exchanger using the P/T plugs and comparing to Table 10.
- d. Check the elevation and cleanliness of the condensate lines. Dripping may be a sign of a blocked line. Check that the condensate trap is filled to provide a water seal. Check the temperature of both entering and leaving water. If temperature is within range table, proceed with the test. If temperature is outside of the operating range, check refrigerant pressures and compare to Table 10. Verify correct water flow by comparing unit pressure drop across the heat exchanger versus the data in Table 10. Heat of rejection

(HR) can be calculated and compared to submittal data capacity pages. The formula for HR for systems with water is as follows:

$$\text{HR (Btuh)} = \text{TD} \times \text{GPM} \times 500$$

where TD is the temperature difference between the entering and leaving water, and GPM is the flow rate in U.S. GPM, determined by comparing the pressure drop across the heat exchanger to table 10. In S-I units, the formula is as follows:

$$\text{HR (kW)} = \text{TD} \times \text{l/s} \times 4.18$$

- e. Check air temperature drop across the air coil when compressor is operating. Air temperature drop should be between 15°F and 25°F (8°C and 14°C).
 - f. Turn thermostat to "OFF" position. A hissing noise indicates proper functioning of the reversing valve.
6. Allow five minutes between tests for pressure to equalize before beginning heating test.
 - a. Adjust the thermostat to the lowest setting Place the thermostat mode switch in the "HEAT" position.
 - b. Slowly raise the thermostat to a higher temperature until the compressor activates.
 - c. Check for warm air delivery within a few minutes after the unit has begun to operate.
 - d. Refer to Table 12. Check the temperature of both entering and leaving water. If temperature is within range, proceed with the test. If temperature is outside of the operating range, check refrigerant pressures and compare to Table 10. Verify correct water flow by comparing unit pressure drop across the heat exchanger versus the data in Table 10. Heat of extraction (HE) can be calculated and compared to submittal data capacity pages.

Unit Startup Procedure

The formula for HE for systems with water is as follows:

$$HE \text{ (Btuh)} = TD \times GPM \times 500$$

where TD is the temperature difference between the entering and leaving water, and GPM is the flow rate in U.S. GPM, determined by comparing the pressure drop across the heat exchanger to Table 10.

- e. In S-I units, Check air temperature rise across the air coil when compressor is operating. Air temperature rise should be between 20°F and 30°F (11°C and 17°C).
 - f. Check for vibration, noise, and water leaks.
7. If unit fails to operate, perform troubleshooting analysis (see troubleshooting section). If the check described fails to reveal the problem and the unit still does not operate, contact a trained service technician to ensure proper diagnosis and repair of the equipment.
 8. When testing is complete, set system to maintain desired comfort level.
 9. **BE CERTAIN TO FILL OUT AND FORWARD ALL WARRANTY REGISTRATION PAPERS TO CLIMATEMASTER.**

WARNING

When the disconnect switch is closed, high voltage is present in some areas of the electrical panel. Exercise caution when working with energized equipment.

CAUTION

Verify that ALL water control valves are open and allow water flow prior to engaging the compressor. Freezing of the coax or water lines can permanently damage the heat pump.

NOTE: If performance during any mode appears abnormal, refer to the CXM2 section or troubleshooting section of this manual. To obtain maximum performance, the air coil should be cleaned before startup. A 10% solution of dishwasher detergent and water is recommended.

Figure 18: Test Mode Button

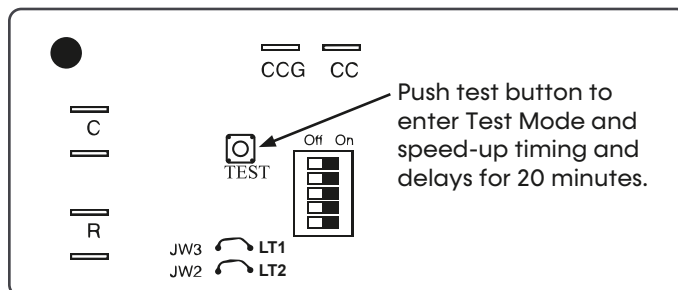

Table 10: Water Pressure Drop

Model	GPM	Pressure Drop (psi)				
		30°F*	50°F	70°F	90°F	110°F
072	9	1.7	1.2	1.0	0.9	0.9
	13.5	3.3	2.4	2.0	2.0	1.8
	18	5.1	3.9	3.4	3.2	3.1
096	12	2.6	2.1	1.9	1.8	1.7
	18	5.4	4.6	4.1	3.8	3.7
	24	8.3	7.1	6.4	5.9	5.6
120	15	2.8	2.6	2.5	2.4	2.3
	22.5	5.9	5.3	5.0	4.7	4.5
	30	9.0	8.0	7.5	7.1	6.7
168	21	1.4	1.3	1.2	1.1	1.1
	31.5	2.7	2.5	2.3	2.2	2.1
	42	4.5	4.1	3.8	3.7	3.6
192	24	2.2	2.0	2.0	1.9	1.8
	36	4.8	4.4	4.2	4.0	3.9
	48	7.4	6.7	6.4	6.2	5.9
240	30	1.8	1.6	1.5	1.4	1.3
	45	4.2	3.6	3.4	3.2	3.1
	60	6.5	5.7	5.3	5.0	4.8
300	37.5	2.4	2.0	1.8	1.7	1.6
	56.25	5.4	4.5	4.0	3.8	3.6
	75	8.4	7.0	6.3	5.9	5.7

*Based on 20% methanol antifreeze solution.

Models:
SB
072-300

Unit Startup Procedure

Table 11: Motorized Water Valve and Modulating Valve Adders

Size	Flow	MWV					MOD Valve				
		Cv	Close Off Pressure	MOPD	Pressure Drop		Cv	Close Off Pressure	MOPD	Pressure Drop	
					PSI	FT				PSI	FT
072	9.00	37	200	50	0.06	0.1	10	200	50	0.81	1.9
	13.50				0.13	0.3				1.82	4.2
	18.00				0.24	0.5				3.24	7.5
096	12.00	37	200	50	0.11	0.2	10	200	50	1.44	3.3
	18.00				0.24	0.5				3.24	7.5
	24.00				0.42	1.0				5.76	13.3
120	15.00	37	200	150	0.16	0.4	19	200	50	0.62	1.4
	22.50				0.37	0.9				1.40	3.2
	30.00				0.66	1.5				2.49	5.8
168	21.00	37	200	150	0.32	0.7	29	200	50	0.52	1.2
	31.50				0.72	1.7				1.18	2.7
	42.00				1.29	3.0				2.10	4.8
192	24.00	37	200	150	0.42	1.0	29	200	50	0.68	1.6
	36.00				0.95	2.2				1.54	3.6
	48.00				1.68	3.9				2.74	6.3
240	30.00	37	200	150	0.66	1.5	29	200	50	1.07	2.5
	45.00				1.48	3.4				2.41	5.6
	60.00				2.63	6.1				4.28	9.9
300	37.50	57	200	150	0.43	1.0	29	200	50	1.67	3.9
	56.25				0.97	2.2				3.76	8.7
	75.00				1.73	4.0				6.69	15.4

PSI values are calculated based on manufacturer-recommended 70°F entering water temperature.

Unit Operating Conditions

Operating Pressure/Temperature tables include the following notes:

- Entering air is based upon 70°F (21°C) DB in heating and 80/67°F (27/19°C) in cooling
- Subcooling is based on head pressure reading taken at the compressor discharge service port and line temperature reading on the discharge line by the compressor discharge service port.
- Cooling air and water values can vary greatly with changes in humidity level

Table 12:SB Series Typical Unit Operating Pressures and Temperatures

SB 072	Entering Water Temp (°F)	Water Flow GPM/ton	CKT1		CKT1		CKT2		CKT2		Water Temp Rise (°F)	Air Temp Drop (°F) DB	Water Temp Drop (°F) ¹	Air Temp Rise (°F) DB
			Discharge Pressure CKT1 (PSIG)	Suction Pressure CKT1 (PSIG)	Superheat CKT1 (°F)	Subcooling CKT1 (°F)	Discharge Pressure CKT2 (PSIG)	Suction Pressure CKT2 (PSIG)	Superheat CKT2 (°F)	Subcooling CKT2 (°F)				
Full Load Cooling	30*	9	162 - 182	107 - 117	17 - 21	13 - 17	152 - 172	100 - 110	13 - 17	13 - 17	19 - 21	19 - 25		
		13.5	152 - 172	105 - 115	16 - 20	14 - 18	142 - 162	99 - 109	11 - 15	14 - 18	14 - 16	19 - 25		
		18	142 - 162	103 - 113	14 - 18	15 - 19	133 - 153	99 - 109	9 - 13	15 - 19	10 - 12	18 - 24		
	50	9	220 - 240	116 - 126	15 - 19	9 - 13	210 - 230	110 - 120	10 - 14	9 - 13	19 - 21	18 - 24		
		13.5	207 - 227	114 - 124	13 - 17	10 - 14	197 - 217	108 - 118	9 - 13	10 - 14	14 - 16	18 - 24		
		18	193 - 213	112 - 122	12 - 16	12 - 16	184 - 204	105 - 115	8 - 12	12 - 16	9 - 11	18 - 24		
	70	9	295 - 315	123 - 133	14 - 18	7 - 11	283 - 303	118 - 128	8 - 12	7 - 11	19 - 21	17 - 23		
		13.5	277 - 297	122 - 132	12 - 16	8 - 12	267 - 287	115 - 125	7 - 11	8 - 12	14 - 16	17 - 23		
		18	260 - 280	120 - 130	10 - 14	9 - 13	251 - 271	113 - 123	7 - 11	9 - 13	9 - 11	17 - 23		
	90	9	382 - 402	129 - 139	15 - 19	6 - 10	368 - 388	124 - 134	7 - 11	6 - 10	18 - 20	16 - 22		
		13.5	363 - 383	128 - 138	12 - 16	6 - 10	351 - 371	123 - 133	6 - 10	6 - 10	14 - 16	16 - 22		
		18	343 - 363	127 - 137	10 - 14	7 - 11	333 - 353	121 - 131	5 - 9	7 - 11	9 - 11	16 - 22		
120	9	535 - 555	136 - 146	17 - 21	5 - 9	518 - 538	133 - 143	6 - 10	5 - 9	18 - 20	14 - 20			
	13.5	515 - 535	135 - 145	15 - 19	5 - 9	500 - 520	132 - 142	5 - 9	5 - 9	13 - 15	14 - 20			
	18	495 - 515	134 - 144	13 - 17	5 - 9	482 - 502	130 - 140	4 - 8	5 - 9	8 - 10	15 - 21			
Full Load Heating	30*	9	265 - 285	60 - 70	8 - 12	6 - 10	259 - 279	60 - 70	8 - 12	6 - 10			8 - 10	18 - 24
		13.5	268 - 288	63 - 73	8 - 12	6 - 10	262 - 282	63 - 73	9 - 13	6 - 10			6 - 8	18 - 24
		18	271 - 291	66 - 76	8 - 12	6 - 10	265 - 285	66 - 76	9 - 13	6 - 10			4 - 6	19 - 25
	50	9	292 - 312	87 - 97	12 - 16	8 - 12	284 - 304	85 - 95	5 - 9	8 - 12			11 - 13	24 - 30
		13.5	296 - 316	90 - 100	12 - 16	9 - 13	288 - 308	89 - 99	6 - 10	9 - 13			8 - 10	25 - 31
		18	300 - 320	94 - 104	12 - 16	9 - 13	292 - 312	92 - 102	6 - 10	9 - 13			5 - 7	26 - 32
	70	9	318 - 338	112 - 122	12 - 16	11 - 15	309 - 329	110 - 120	5 - 9	11 - 15			14 - 16	30 - 36
		13.5	324 - 344	117 - 127	12 - 16	12 - 16	314 - 334	115 - 125	5 - 9	12 - 16			10 - 12	31 - 37
		18	329 - 349	123 - 133	13 - 17	12 - 16	319 - 339	119 - 129	5 - 9	12 - 16			7 - 9	32 - 38
	90	9	344 - 364	139 - 149	12 - 16	14 - 18	334 - 354	136 - 146	4 - 8	14 - 18			17 - 19	35 - 41
		13.5	351 - 371	146 - 156	12 - 16	16 - 20	340 - 360	142 - 152	4 - 8	16 - 20			13 - 15	36 - 42
		18	358 - 378	153 - 163	12 - 16	17 - 21	347 - 367	149 - 159	4 - 8	17 - 21			9 - 11	37 - 43
120	9													
	13.5													
	18													

* Based on 20% Methanol antifreeze solution.

Models:
SB
072-300

Unit Operating Conditions

SB 096	Entering Water Temp (°F)	Water Flow GPM/ton	CKT1		CKT1		CKT2		CKT2		Water Temp Rise (°F)	Air Temp Drop (°F) DB	Water Temp Drop (°F)"	Air Temp Rise (°F) DB
			Discharge Pressure CKT1 (PSIG)	Suction Pressure CKT1 (PSIG)	Superheat CKT1 (°F)	Subcooling CKT1 (°F)	Discharge Pressure CKT2 (PSIG)	Suction Pressure CKT2 (PSIG)	Superheat CKT2 (°F)	Subcooling CKT2 (°F)				
Full Load Cooling	30*	12	167 - 187	106 - 116	16 - 20	12 - 16	161 - 181	106 - 116	5 - 9	12 - 16	20 - 22	20 - 26		
		18	155 - 175	104 - 114	14 - 18	13 - 17	150 - 170	104 - 114	3 - 7	13 - 17	15 - 17	20 - 26		
		24	144 - 164	101 - 111	11 - 15	13 - 17	139 - 159	101 - 111	1 - 5	13 - 17	10 - 12	20 - 26		
	50	12	217 - 237	115 - 125	15 - 19	9 - 13	210 - 230	113 - 123	11 - 15	9 - 13	21 - 23	19 - 25		
		18	202 - 222	112 - 122	13 - 17	10 - 14	197 - 217	111 - 121	9 - 13	10 - 14	15 - 17	19 - 25		
		24	188 - 208	110 - 120	12 - 16	11 - 15	183 - 203	109 - 119	7 - 11	11 - 15	10 - 12	19 - 25		
	70	12	284 - 304	122 - 132	15 - 19	8 - 12	276 - 296	120 - 130	11 - 15	8 - 12	21 - 23	18 - 24		
		18	266 - 286	120 - 130	13 - 17	8 - 12	260 - 280	118 - 128	9 - 13	8 - 12	15 - 17	18 - 24		
		24	249 - 269	118 - 128	11 - 15	9 - 13	244 - 264	117 - 127	7 - 11	9 - 13	10 - 12	18 - 24		
	90	12	367 - 387	128 - 138	15 - 19	6 - 10	357 - 377	126 - 136	10 - 14	6 - 10	20 - 22	17 - 23		
		18	347 - 367	126 - 136	12 - 16	6 - 10	339 - 359	125 - 135	8 - 12	6 - 10	15 - 17	17 - 23		
		24	327 - 347	125 - 135	10 - 14	7 - 11	321 - 341	124 - 134	6 - 10	7 - 11	10 - 12	17 - 23		
120	12	519 - 539	135 - 145	17 - 21	4 - 8	508 - 528	133 - 143	22 - 26	4 - 8	19 - 21	15 - 21			
	18	497 - 517	134 - 144	14 - 18	5 - 9	488 - 508	132 - 142	20 - 24	5 - 9	14 - 16	15 - 21			
	24	476 - 496	134 - 144	12 - 16	5 - 9	468 - 488	132 - 142	17 - 21	5 - 9	9 - 11	15 - 21			
Full Load Heating	30*	12	274 - 294	58 - 68	14 - 18	8 - 12	268 - 288	57 - 67	12 - 16	8 - 12			6 - 8	19 - 25
		18	272 - 292	57 - 67	13 - 17	8 - 12	267 - 287	55 - 65	11 - 15	8 - 12			7 - 9	19 - 25
		24	270 - 290	55 - 65	13 - 17	7 - 11	265 - 285	54 - 64	11 - 15	7 - 11			7 - 9	18 - 24
	50	12	299 - 319	80 - 90	16 - 20	9 - 13	293 - 313	79 - 89	14 - 18	9 - 13			11 - 13	25 - 31
		18	304 - 324	84 - 94	16 - 20	10 - 14	299 - 319	83 - 93	14 - 18	10 - 14			8 - 10	26 - 32
		24	309 - 329	89 - 99	16 - 20	10 - 14	304 - 324	88 - 98	14 - 18	10 - 14			6 - 8	27 - 33
	70	12	330 - 350	107 - 117	16 - 20	11 - 15	324 - 344	107 - 117	14 - 18	11 - 15			15 - 17	31 - 37
		18	337 - 357	114 - 124	16 - 20	11 - 15	331 - 351	114 - 124	14 - 18	11 - 15			11 - 13	32 - 38
		24	344 - 364	120 - 130	16 - 20	12 - 16	339 - 359	121 - 131	13 - 17	12 - 16			8 - 10	34 - 40
	90	12	364 - 384	139 - 149	14 - 18	13 - 17	358 - 378	140 - 150	11 - 15	13 - 17			19 - 21	38 - 44
		18	372 - 392	147 - 157	14 - 18	14 - 18	367 - 387	148 - 158	10 - 14	14 - 18			14 - 16	39 - 45
		24	381 - 401	155 - 165	13 - 17	15 - 19	375 - 395	157 - 167	9 - 13	15 - 19			10 - 12	41 - 47
120	12													
	18													
	24													

* Based on 20% Methanol antifreeze solution.

Unit Operating Conditions

SB 120	Entering Water Temp (°F)	Water Flow GPM/ton	CKT1		CKT1		CKT2		CKT2		Water Temp Rise (°F)	Air Temp Drop (°F) DB	Water Temp Drop (°F)"	Air Temp Rise (°F) DB
			Discharge Pressure CKT1 (PSIG)	Suction Pressure CKT1 (PSIG)	Superheat CKT1 (°F)	Subcooling CKT1 (°F)	Discharge Pressure CKT2 (PSIG)	Suction Pressure CKT2 (PSIG)	Superheat CKT2 (°F)	Subcooling CKT2 (°F)				
Full Load Cooling	30*	15	184 - 204	93 - 103	34 - 38	18 - 22	188 - 208	91 - 101	32 - 36	18 - 22	23 - 25	17 - 23		
		22.5	163 - 183	86 - 96	29 - 33	25 - 29	167 - 187	82 - 92	16 - 20	25 - 29	16 - 18	15 - 21		
		30	141 - 161	78 - 88	25 - 29	31 - 35	145 - 165	73 - 83	0 - 4	31 - 35	9 - 11	14 - 20		
	50	15	226 - 246	107 - 117	22 - 26	13 - 17	229 - 249	106 - 116	20 - 24	13 - 17	21 - 23	18 - 24		
		22.5	209 - 229	100 - 110	21 - 25	18 - 22	212 - 232	101 - 111	15 - 19	18 - 22	15 - 17	17 - 23		
		30	193 - 213	93 - 103	20 - 24	23 - 27	195 - 215	96 - 106	9 - 13	23 - 27	9 - 11	16 - 22		
	70	15	290 - 310	115 - 125	18 - 22	9 - 13	293 - 313	115 - 125	16 - 20	9 - 13	20 - 22	17 - 23		
		22.5	274 - 294	111 - 121	17 - 21	12 - 16	276 - 296	113 - 123	14 - 18	12 - 16	15 - 17	17 - 23		
		30	257 - 277	106 - 116	16 - 20	15 - 19	259 - 279	110 - 120	12 - 16	15 - 19	9 - 11	17 - 23		
	90	15	374 - 394	120 - 130	19 - 23	6 - 10	379 - 399	121 - 131	16 - 20	6 - 10	20 - 22	16 - 22		
		22.5	355 - 375	118 - 128	16 - 20	7 - 11	358 - 378	120 - 130	14 - 18	7 - 11	15 - 17	16 - 22		
		30	335 - 355	117 - 127	14 - 18	9 - 13	338 - 358	119 - 129	12 - 16	9 - 13	9 - 11	16 - 22		
120	15	529 - 549	126 - 136	20 - 24	3 - 7	535 - 555	126 - 136	19 - 23	3 - 7	19 - 21	14 - 20			
	22.5	506 - 526	126 - 136	18 - 22	4 - 8	511 - 531	127 - 137	16 - 20	4 - 8	14 - 16	15 - 21			
	30	483 - 503	126 - 136	15 - 19	5 - 9	487 - 507	127 - 137	13 - 17	5 - 9	9 - 11	15 - 21			
Full Load Heating	30*	15	278 - 298	51 - 61	16 - 20	5 - 9	277 - 297	50 - 60	14 - 18	5 - 9			8 - 10	19 - 25
		22.5	281 - 301	54 - 64	17 - 21	5 - 9	281 - 301	53 - 63	14 - 18	5 - 9			6 - 8	20 - 26
		30	285 - 305	57 - 67	17 - 21	5 - 9	285 - 305	56 - 66	15 - 19	5 - 9			4 - 6	20 - 26
	50	15	313 - 333	78 - 88	18 - 22	4 - 8	312 - 332	76 - 86	15 - 19	4 - 8			11 - 13	26 - 32
		22.5	318 - 338	82 - 92	18 - 22	4 - 8	318 - 338	81 - 91	15 - 19	4 - 8			8 - 10	27 - 33
		30	324 - 344	86 - 96	17 - 21	4 - 8	324 - 344	85 - 95	15 - 19	4 - 8			5 - 7	28 - 34
	70	15	346 - 366	106 - 116	18 - 22	7 - 11	347 - 367	104 - 114	16 - 20	7 - 11			14 - 16	32 - 38
		22.5	355 - 375	113 - 123	17 - 21	7 - 11	355 - 375	111 - 121	15 - 19	7 - 11			11 - 13	34 - 40
		30	363 - 383	120 - 130	17 - 21	7 - 11	364 - 384	118 - 128	15 - 19	7 - 11			7 - 9	35 - 41
	90	15	385 - 405	140 - 150	16 - 20	10 - 14	385 - 405	137 - 147	14 - 18	10 - 14			18 - 20	39 - 45
		22.5	393 - 413	145 - 155	17 - 21	14 - 18	394 - 414	144 - 154	15 - 19	14 - 18			14 - 16	41 - 47
		30	401 - 421	151 - 161	18 - 22	17 - 21	402 - 422	151 - 161	15 - 19	17 - 21			9 - 11	42 - 48
120	15													
	22.5													
	30													

* Based on 20% Methanol antifreeze solution.

Models:
SB
072-300

Unit Operating Conditions

SB 168	Entering Water Temp (°F)	Water Flow GPM/ton	CKT1		CKT1		CKT2		CKT2		Water Temp Rise (°F)	Air Temp Drop (°F) DB	Water Temp Drop (°F)"	Air Temp Rise (°F) DB
			Discharge Pressure CKT1 (PSIG)	Suction Pressure CKT1 (PSIG)	Superheat CKT1 (°F)	Subcooling CKT1 (°F)	Discharge Pressure CKT2 (PSIG)	Suction Pressure CKT2 (PSIG)	Superheat CKT2 (°F)	Subcooling CKT2 (°F)				
Full Load Cooling	30*	21	158 - 178	103 - 113	18 - 22	14 - 18	169 - 189	104 - 114	22 - 26	14 - 18	21 - 23	21 - 27		
		31.5	146 - 166	97 - 107	18 - 22	17 - 21	155 - 175	97 - 107	21 - 25	17 - 21	15 - 17	20 - 26		
		42	134 - 154	92 - 102	17 - 21	19 - 23	142 - 162	90 - 100	20 - 24	19 - 23	9 - 11	19 - 25		
	50	21	213 - 233	110 - 120	16 - 20	9 - 13	224 - 244	108 - 118	22 - 26	9 - 13	20 - 22	20 - 26		
		31.5	199 - 219	108 - 118	14 - 18	11 - 15	207 - 227	106 - 116	19 - 23	11 - 15	15 - 17	20 - 26		
		42	184 - 204	106 - 116	12 - 16	12 - 16	191 - 211	103 - 113	17 - 21	12 - 16	9 - 11	20 - 26		
	70	21	284 - 304	115 - 125	15 - 19	7 - 11	295 - 315	112 - 122	22 - 26	7 - 11	20 - 22	19 - 25		
		31.5	267 - 287	114 - 124	13 - 17	8 - 12	277 - 297	111 - 121	19 - 23	8 - 12	14 - 16	19 - 25		
		42	250 - 270	113 - 123	10 - 14	9 - 13	258 - 278	110 - 120	16 - 20	9 - 13	9 - 11	19 - 25		
	90	21	368 - 388	120 - 130	16 - 20	6 - 10	382 - 402	116 - 126	22 - 26	6 - 10	19 - 21	19 - 25		
		31.5	350 - 370	119 - 129	13 - 17	7 - 11	361 - 381	115 - 125	19 - 23	7 - 11	14 - 16	19 - 25		
		42	331 - 351	118 - 128	11 - 15	7 - 11	341 - 361	115 - 125	16 - 20	7 - 11	9 - 11	19 - 25		
120	21	520 - 540	126 - 136	16 - 20	5 - 9	534 - 554	124 - 134	21 - 25	5 - 9	18 - 20	17 - 23			
	31.5	499 - 519	126 - 136	14 - 18	5 - 9	512 - 532	123 - 133	18 - 22	5 - 9	13 - 15	17 - 23			
	42	479 - 499	125 - 135	12 - 16	6 - 10	489 - 509	123 - 133	16 - 20	6 - 10	9 - 11	17 - 23			
Full Load Heating	30*	21	284 - 304	55 - 65	10 - 14	13 - 17	282 - 302	54 - 64	9 - 13	13 - 17			3 - 5	18 - 24
		31.5	279 - 299	52 - 62	9 - 13	13 - 17	277 - 297	51 - 61	8 - 12	13 - 17			5 - 7	17 - 23
		42	274 - 294	48 - 58	8 - 12	13 - 17	272 - 292	47 - 57	7 - 11	13 - 17			6 - 8	16 - 22
	50	21	310 - 330	74 - 84	13 - 17	13 - 17	306 - 326	71 - 81	13 - 17	13 - 17			9 - 11	23 - 29
		31.5	316 - 336	78 - 88	13 - 17	13 - 17	312 - 332	75 - 85	14 - 18	13 - 17			7 - 9	24 - 30
		42	321 - 341	83 - 93	14 - 18	14 - 18	318 - 338	80 - 90	14 - 18	14 - 18			5 - 7	25 - 31
	70	21	344 - 364	101 - 111	15 - 19	15 - 19	340 - 360	96 - 106	16 - 20	15 - 19			13 - 15	29 - 35
		31.5	350 - 370	107 - 117	15 - 19	15 - 19	346 - 366	102 - 112	16 - 20	15 - 19			10 - 12	30 - 36
		42	357 - 377	113 - 123	15 - 19	16 - 20	353 - 373	108 - 118	17 - 21	16 - 20			7 - 9	31 - 37
	90	21	380 - 400	133 - 143	14 - 18	17 - 21	374 - 394	126 - 136	16 - 20	17 - 21			17 - 19	35 - 41
		31.5	388 - 408	139 - 149	14 - 18	18 - 22	382 - 402	132 - 142	16 - 20	18 - 22			12 - 14	36 - 42
		42	396 - 416	146 - 156	14 - 18	19 - 23	390 - 410	139 - 149	16 - 20	19 - 23			8 - 10	37 - 43
120	21													
	31.5													
	42													

* Based on 20% Methanol antifreeze solution.

Models:
SB
072-300

Unit Operating Conditions

SB 192	Entering Water Temp (°F)	Water Flow GPM/ton	CKT1		CKT1		CKT2		CKT2		Water Temp Rise (°F)	Air Temp Drop (°F) DB	Water Temp Drop (°F)"	Air Temp Rise (°F) DB
			Discharge Pressure CKT1 (PSIG)	Suction Pressure CKT1 (PSIG)	Superheat CKT1 (°F)	Subcooling CKT1 (°F)	Discharge Pressure CKT2 (PSIG)	Suction Pressure CKT2 (PSIG)	Superheat CKT2 (°F)	Subcooling CKT2 (°F)				
Full Load Cooling	30*	24	173 - 193	104 - 114	20 - 24	11 - 15	179 - 199	103 - 113	21 - 25	11 - 15	23 - 25	20 - 26		
		36	151 - 171	101 - 111	15 - 19	14 - 18	156 - 176	100 - 110	16 - 20	14 - 18	16 - 18	20 - 26		
		48	129 - 149	97 - 107	10 - 14	16 - 20	132 - 152	97 - 107	10 - 14	16 - 20	9 - 11	19 - 25		
	50	24	208 - 228	112 - 122	16 - 20	8 - 12	213 - 233	111 - 121	17 - 21	8 - 12	20 - 22	20 - 26		
		36	195 - 215	110 - 120	14 - 18	10 - 14	199 - 219	109 - 119	15 - 19	10 - 14	15 - 17	20 - 26		
		48	182 - 202	107 - 117	12 - 16	11 - 15	185 - 205	106 - 116	13 - 17	11 - 15	9 - 11	20 - 26		
	70	24	268 - 288	118 - 128	15 - 19	7 - 11	273 - 293	117 - 127	17 - 21	7 - 11	19 - 21	19 - 25		
		36	256 - 276	116 - 126	14 - 18	7 - 11	260 - 280	115 - 125	16 - 20	7 - 11	14 - 16	19 - 25		
		48	243 - 263	114 - 124	13 - 17	8 - 12	247 - 267	113 - 123	14 - 18	8 - 12	9 - 11	19 - 25		
	90	24	348 - 368	122 - 132	17 - 21	6 - 10	353 - 373	121 - 131	19 - 23	6 - 10	18 - 20	19 - 25		
		36	333 - 353	121 - 131	15 - 19	6 - 10	337 - 357	119 - 129	17 - 21	6 - 10	13 - 15	19 - 25		
		48	318 - 338	119 - 129	13 - 17	7 - 11	320 - 340	118 - 128	14 - 18	7 - 11	9 - 11	19 - 25		
120	24	496 - 516	129 - 139	18 - 22	5 - 9	499 - 519	128 - 138	19 - 23	5 - 9	17 - 19	17 - 23			
	36	478 - 498	128 - 138	16 - 20	6 - 10	480 - 500	127 - 137	17 - 21	6 - 10	12 - 14	17 - 23			
	48	461 - 481	127 - 137	14 - 18	6 - 10	461 - 481	126 - 136	15 - 19	6 - 10	8 - 10	17 - 23			
Full Load Heating	30*	24	254 - 274	51 - 61	9 - 13	8 - 12	252 - 272	53 - 63	5 - 9	8 - 12			7 - 9	16 - 22
		36	257 - 277	54 - 64	9 - 13	8 - 12	255 - 275	56 - 66	5 - 9	8 - 12			5 - 7	17 - 23
		48	261 - 281	57 - 67	10 - 14	7 - 11	258 - 278	59 - 69	5 - 9	7 - 11			3 - 5	18 - 24
	50	24	283 - 303	78 - 88	12 - 16	10 - 14	279 - 299	77 - 87	8 - 12	10 - 14			10 - 12	22 - 28
		36	287 - 307	82 - 92	13 - 17	10 - 14	283 - 303	81 - 91	8 - 12	10 - 14			7 - 9	23 - 29
		48	292 - 312	87 - 97	13 - 17	10 - 14	287 - 307	85 - 95	8 - 12	10 - 14			5 - 7	24 - 30
	70	24	311 - 331	107 - 117	12 - 16	10 - 14	306 - 326	104 - 114	8 - 12	10 - 14			13 - 15	28 - 34
		36	317 - 337	114 - 124	11 - 15	11 - 15	311 - 331	110 - 120	8 - 12	11 - 15			10 - 12	29 - 35
		48	323 - 343	121 - 131	10 - 14	11 - 15	317 - 337	116 - 126	7 - 11	11 - 15			7 - 9	31 - 37
	90	24	341 - 361	141 - 151	9 - 13	13 - 17	334 - 354	135 - 145	5 - 9	13 - 17			17 - 19	34 - 40
		36	347 - 367	147 - 157	8 - 12	14 - 18	340 - 360	142 - 152	4 - 8	14 - 18			13 - 15	35 - 41
		48	353 - 373	154 - 164	8 - 12	15 - 19	345 - 365	149 - 159	4 - 8	15 - 19			9 - 11	36 - 42
120	24													
	36													
	48													

* Based on 20% Methanol antifreeze solution.

Models:
SB
072-300

Unit Operating Conditions

SB 240	Entering Water Temp (°F)	Water Flow GPM/ton	CKT1		CKT1		CKT2		CKT2		Water Temp Rise (°F)	Air Temp Drop (°F) DB	Water Temp Drop (°F)"	Air Temp Rise (°F) DB
			Discharge Pressure CKT1 (PSIG)	Suction Pressure CKT1 (PSIG)	Superheat CKT1 (°F)	Subcooling CKT1 (°F)	Discharge Pressure CKT2 (PSIG)	Suction Pressure CKT2 (PSIG)	Superheat CKT2 (°F)	Subcooling CKT2 (°F)				
Full Load Cooling	30*	30	181 - 201	105 - 115	18 - 22	12 - 16	191 - 211	108 - 118	19 - 23	12 - 16	22 - 24	19 - 25		
		45	158 - 178	97 - 107	16 - 20	17 - 21	165 - 185	100 - 110	17 - 21	17 - 21	15 - 17	19 - 25		
		60	136 - 156	89 - 99	13 - 17	22 - 26	139 - 159	92 - 102	15 - 19	22 - 26	9 - 11	18 - 24		
	50	30	218 - 238	112 - 122	16 - 20	9 - 13	227 - 247	113 - 123	16 - 20	9 - 13	20 - 22	19 - 25		
		45	205 - 225	110 - 120	14 - 18	11 - 15	211 - 231	111 - 121	15 - 19	11 - 15	15 - 17	19 - 25		
		60	191 - 211	107 - 117	12 - 16	12 - 16	195 - 215	109 - 119	13 - 17	12 - 16	9 - 11	19 - 25		
	70	30	280 - 300	117 - 127	15 - 19	7 - 11	289 - 309	117 - 127	15 - 19	7 - 11	19 - 21	18 - 24		
		45	265 - 285	116 - 126	13 - 17	8 - 12	271 - 291	116 - 126	13 - 17	8 - 12	14 - 16	18 - 24		
		60	250 - 270	115 - 125	10 - 14	8 - 12	254 - 274	115 - 125	10 - 14	8 - 12	9 - 11	18 - 24		
	90	30	363 - 383	121 - 131	16 - 20	5 - 9	372 - 392	121 - 131	15 - 19	5 - 9	18 - 20	17 - 23		
		45	342 - 362	119 - 129	13 - 17	6 - 10	348 - 368	119 - 129	12 - 16	6 - 10	13 - 15	17 - 23		
		60	321 - 341	118 - 128	10 - 14	7 - 11	325 - 345	118 - 128	8 - 12	7 - 11	8 - 10	17 - 23		
120	30	516 - 536	127 - 137	18 - 22	5 - 9	523 - 543	128 - 138	15 - 19	5 - 9	17 - 19	16 - 22			
	45	497 - 517	126 - 136	15 - 19	5 - 9	502 - 522	127 - 137	13 - 17	5 - 9	13 - 15	16 - 22			
	60	477 - 497	126 - 136	13 - 17	5 - 9	480 - 500	127 - 137	10 - 14	5 - 9	8 - 10	16 - 22			
Full Load Heating	30*	30	260 - 280	60 - 70	16 - 20	7 - 11	270 - 290	56 - 66	17 - 21	7 - 11			3 - 5	17 - 23
		45	262 - 282	54 - 64	16 - 20	8 - 12	267 - 287	51 - 61	17 - 21	8 - 12			5 - 7	17 - 23
		60	263 - 283	48 - 58	17 - 21	9 - 13	263 - 283	47 - 57	16 - 20	9 - 13			7 - 9	16 - 22
	50	30	289 - 309	94 - 104	17 - 21	7 - 11	303 - 323	85 - 95	19 - 23	7 - 11			4 - 6	23 - 29
		45	294 - 314	85 - 95	19 - 23	8 - 12	301 - 321	80 - 90	19 - 23	8 - 12			7 - 9	23 - 29
		60	299 - 319	75 - 85	20 - 24	8 - 12	298 - 318	74 - 84	19 - 23	8 - 12			10 - 12	23 - 29
	70	30	352 - 372	119 - 129	21 - 25	10 - 14	349 - 369	117 - 127	19 - 23	10 - 14			7 - 9	33 - 39
		45	343 - 363	111 - 121	21 - 25	10 - 14	340 - 360	109 - 119	19 - 23	10 - 14			10 - 12	31 - 37
		60	335 - 355	104 - 114	21 - 25	9 - 13	332 - 352	102 - 112	20 - 24	9 - 13			13 - 15	30 - 36
	90	30	395 - 415	155 - 165	19 - 23	14 - 18	392 - 412	154 - 164	16 - 20	14 - 18			9 - 11	41 - 47
		45	385 - 405	146 - 156	19 - 23	12 - 16	381 - 401	144 - 154	17 - 21	12 - 16			13 - 15	39 - 45
		60	374 - 394	138 - 148	20 - 24	11 - 15	371 - 391	134 - 144	18 - 22	11 - 15			17 - 19	37 - 43
120	30													
	45													
	60													

* Based on 20% Methanol antifreeze solution.

Models:
SB
072-300

Unit Operating Conditions

SB 300	Entering Water Temp (°F)	Water Flow GPM/ton	CKT1		CKT1		CKT2		CKT2		Water Temp Rise (°F)	Air Temp Drop (°F) DB	Water Temp Drop (°F)''	Air Temp Rise (°F) DB
			Discharge Pressure CKT1 (PSIG)	Suction Pressure CKT1 (PSIG)	Superheat CKT1 (°F)	Subcooling CKT1 (°F)	Discharge Pressure CKT2 (PSIG)	Suction Pressure CKT2 (PSIG)	Superheat CKT2 (°F)	Subcooling CKT2 (°F)				
Full Load Cooling	30*	37.5	171 - 191	112 - 122	4 - 8	4 - 8	178 - 198	113 - 123	14 - 18	4 - 8	21 - 23	19 - 25		
		56.25	166 - 186	113 - 123	4 - 8	5 - 9	171 - 191	115 - 125	10 - 14	5 - 9	16 - 18	19 - 25		
		75	161 - 181	114 - 124	4 - 8	6 - 10	164 - 184	117 - 127	6 - 10	6 - 10	12 - 14	19 - 25		
	50	37.5	216 - 236	114 - 124	5 - 9	4 - 8	225 - 245	116 - 126	14 - 18	4 - 8	20 - 22	19 - 25		
		56.25	205 - 225	114 - 124	3 - 7	4 - 8	212 - 232	116 - 126	11 - 15	4 - 8	15 - 17	19 - 25		
		75	194 - 214	114 - 124	2 - 6	5 - 9	199 - 219	116 - 126	7 - 11	5 - 9	10 - 12	19 - 25		
	70	37.5	280 - 300	118 - 128	7 - 11	3 - 7	291 - 311	120 - 130	15 - 19	3 - 7	20 - 22	18 - 24		
		56.25	265 - 285	117 - 127	4 - 8	4 - 8	274 - 294	119 - 129	12 - 16	4 - 8	15 - 17	18 - 24		
		75	250 - 270	117 - 127	2 - 6	4 - 8	257 - 277	119 - 129	9 - 13	4 - 8	9 - 11	18 - 24		
	90	37.5	361 - 381	122 - 132	8 - 12	3 - 7	374 - 394	124 - 134	15 - 19	3 - 7	19 - 21	17 - 23		
		56.25	344 - 364	121 - 131	6 - 10	3 - 7	355 - 375	123 - 133	12 - 16	3 - 7	14 - 16	17 - 23		
		75	326 - 346	120 - 130	3 - 7	3 - 7	335 - 355	123 - 133	9 - 13	3 - 7	9 - 11	17 - 23		
120	37.5	508 - 528	129 - 139	9 - 13	2 - 6	525 - 545	131 - 141	15 - 19	2 - 6	18 - 20	15 - 21			
	56.25	489 - 509	128 - 138	7 - 11	2 - 6	503 - 523	130 - 140	12 - 16	2 - 6	13 - 15	15 - 21			
	75	471 - 491	128 - 138	5 - 9	2 - 6	482 - 502	130 - 140	10 - 14	2 - 6	9 - 11	16 - 22			
Full Load Heating	30*	37.5	266 - 286	48 - 58	6 - 10	7 - 11	267 - 287	47 - 57	7 - 11	7 - 11			6 - 8	16 - 22
		56.25	271 - 291	52 - 62	7 - 11	7 - 11	271 - 291	51 - 61	7 - 11	7 - 11			5 - 7	17 - 23
		75	275 - 295	55 - 65	7 - 11	7 - 11	275 - 295	54 - 64	8 - 12	7 - 11			3 - 5	18 - 24
	50	37.5	301 - 321	74 - 84	11 - 15	6 - 10	301 - 321	74 - 84	13 - 17	6 - 10			10 - 12	23 - 29
		56.25	306 - 326	78 - 88	11 - 15	6 - 10	307 - 327	79 - 89	14 - 18	6 - 10			7 - 9	24 - 30
		75	311 - 331	83 - 93	12 - 16	6 - 10	313 - 333	83 - 93	15 - 19	6 - 10			5 - 7	25 - 31
	70	37.5	337 - 357	104 - 114	14 - 18	7 - 11	338 - 358	102 - 112	17 - 21	7 - 11			14 - 16	30 - 36
		56.25	345 - 365	111 - 121	13 - 17	7 - 11	346 - 366	109 - 119	17 - 21	7 - 11			10 - 12	32 - 38
		75	353 - 373	118 - 128	13 - 17	7 - 11	355 - 375	116 - 126	17 - 21	7 - 11			7 - 9	33 - 39
	90	37.5	376 - 396	138 - 148	11 - 15	8 - 12	379 - 399	135 - 145	17 - 21	8 - 12			18 - 20	37 - 43
		56.25	387 - 407	148 - 158	10 - 14	9 - 13	388 - 408	145 - 155	16 - 20	9 - 13			13 - 15	39 - 45
		75	398 - 418	159 - 169	9 - 13	9 - 13	398 - 418	155 - 165	15 - 19	9 - 13			9 - 11	41 - 47
120	37.5													
	56.25													
	75													

* Based on 20% Methanol antifreeze solution.

Models:
SB
072-300

Startup Log Sheet

7300 S.W. 44th Street, Oklahoma City, OK 73179 • Phone: 405.745-6000

Installer: Complete *Unit and System Checkout* and follow *Unit Startup Procedures* in the IOM. Use this form to record unit information, temperatures, and pressures during startup. Keep this form for reference.

Job Name: _____

Street Address: _____

Model Number: _____ **Serial Number:** _____

Unit Location in Building: _____

Date: _____ **Sales Order Number:** _____

In order to minimize troubleshooting and costly system failures, complete the following checks and data entries before the system is put into full operation.

External Static: _____

Sheave Setting: _____ Turns Open

Temperatures (check one): °F °C Antifreeze: _____ %

Pressures (check one): PSIG kPa Type: _____

	Cooling Mode		Heating Mode
Entering Fluid Temperature			
Leaving Fluid Temperature			
Fluid Temperature Differential			
Return-Air Temperature	DB	WB	DB
Supply-Air Temperature	DB	WB	DB
Air Temperature Differential			
Water Coil Heat Exchanger (Water Pressure IN)			
Water Coil Heat Exchanger (Water Pressure OUT)			
Pressure Differential			
Flow Rate GPM (l/s)			
Compressor			
Amps			
Volts			
Discharge Line Temperature			
Motor			
Amps			
Volts			

- NOTES:**
- Allow unit to run 15 minutes in each mode before taking data.
 - Never connect refrigerant gauges during startup procedures.
 - Conduct water-side analysis using P/T ports to determine water flow and temperature difference.
 - If water-side analysis shows poor performance, refrigerant troubleshooting may be required.
 - Connect refrigerant gauges as a last resort.

Preventative Maintenance

WATER COIL MAINTENANCE (WATER LOOP APPLICATIONS)

Generally water coil maintenance is not needed for closed loop systems. However, if the piping is known to have high dirt or debris content, it is best to establish a periodic maintenance schedule with the owner so the water coil can be checked regularly. Dirty installations are typically the result of deterioration of iron or galvanized piping or components in the system. Open cooling towers requiring heavy chemical treatment and mineral buildup through water use can also contribute to higher maintenance. Should periodic coil cleaning be necessary, use standard coil cleaning procedures, which are compatible with both the heat exchanger material and copper water lines. Generally, the more water flowing through the unit, the less chance for scaling. However, flow rates over 3 gpm per ton (3.9 l/m per kW) can produce water (or debris) velocities that can erode the heat exchanger wall and ultimately produce leaks.

HOT WATER GENERATOR COILS

See water coil maintenance for ground water units. If the potable water is hard or not chemically softened, the high temperatures of the desuperheater will tend to scale even quicker than the water coil and may need more frequent inspections. In areas with extremely hard water, a HWG is not recommended.

FILTERS

Filters must be clean to obtain maximum performance. Filters should be inspected every month under normal operating conditions and be replaced when necessary. Units should never be operated without a filter.

CONDENSATE DRAIN

In areas where airborne bacteria may produce a “slimy” substance in the drain pan, it may be necessary to treat the drain pan chemically with an algacide approximately every three months to minimize the problem. The condensate pan may also need to be cleaned periodically to ensure indoor air quality. The condensate drain can pick up lint and dirt, especially with dirty filters. Inspect the drain twice a year to avoid the possibility of plugging and eventual overflow.

COMPRESSOR

Conduct annual amperage checks to ensure that amp draw is no more than 10% greater than indicated on the serial dataplate.

AIR COIL

The air coil must be cleaned to obtain maximum performance. Check once a year under normal operating conditions and, if dirty, brush or vacuum clean. Care must be taken not to damage the aluminum fins while cleaning.

CAUTION

Fin edges are sharp and may cause injury.

BELT

Ensure the belt is tight. Retighten if needed. Replace if it is split or cracked.

CABINET

Do not allow water to stay in contact with the cabinet for long periods of time to prevent corrosion of the cabinet sheet metal. Generally, vertical cabinets are set up from the floor a few inches (7 - 8 cm) to prevent water from entering the cabinet. The cabinet can be cleaned using a mild detergent.







REPAIRS TO SEALED COMPONENTS

Sealed electrical components shall be replaced.

Models:
SB
072-300

Circuit Diagram with Safety Devices

SYMBOL LEGEND

-  = TEMPERATURE SENSOR
-  = PRESSURE SWITCH
-  = REFRIGERANT FLOW COOLING MODE
-  = REFRIGERANT FLOW HEATING MODE
-  = REFRIGERANT FLOW EITHER MODE
-  = WATER FLOW

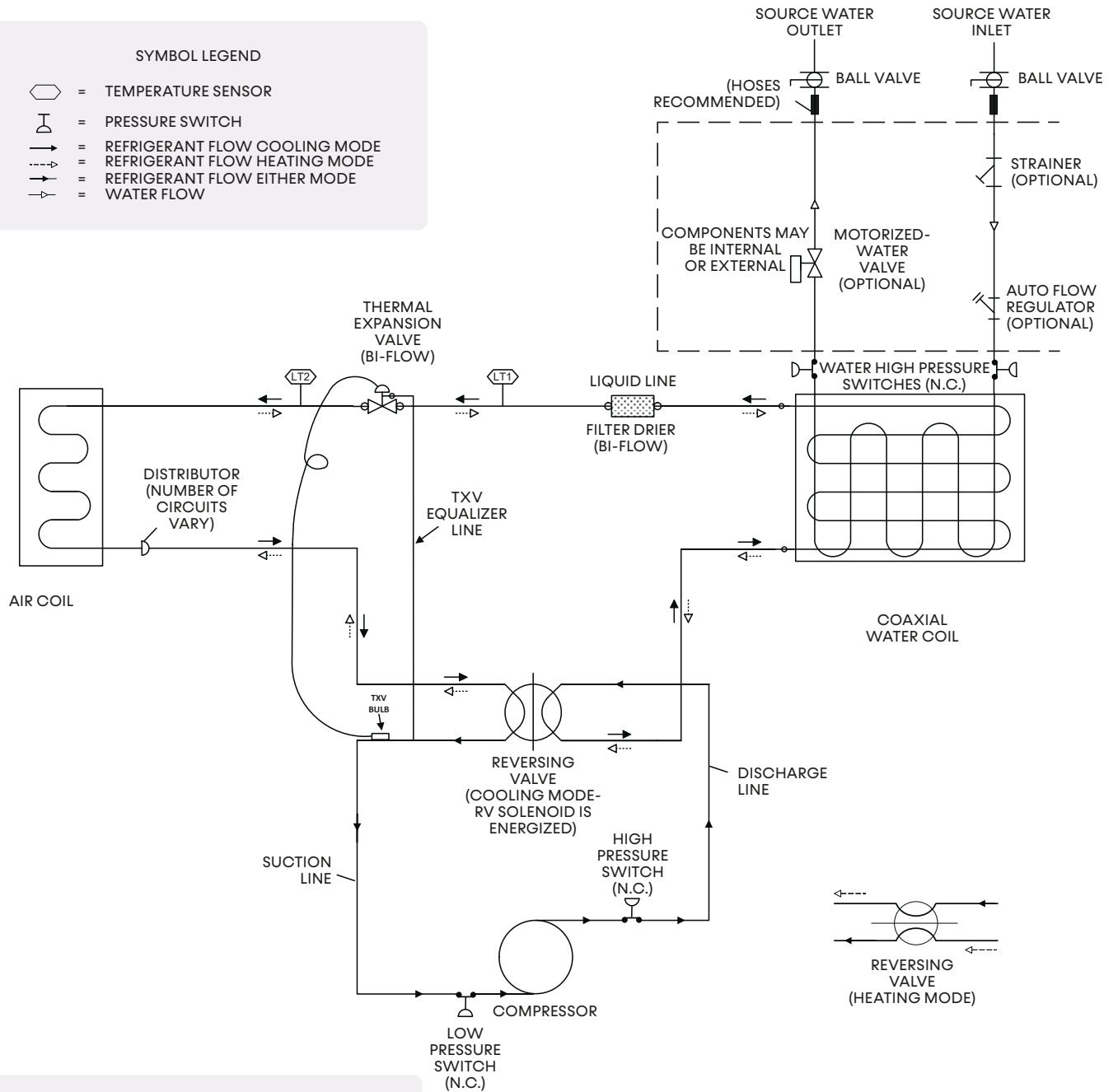

Notes:

1. LT1 and LT2 sensors connect to CXM2
2. Refrigerant high and low pressure switches connect to CXM2
3. Water high pressure switches are wired in series with refrigerant high pressure switch.

Functional Troubleshooting

Fault	Htg	Clg	Possible Cause	Solution
Main power problems	X	X	Green Status LED Off	Check line voltage circuit breaker and disconnect.
				Check for line voltage between L1 and L2 on the contactor.
				Check for 24VAC between R and C on CXM2
				Check primary/secondary voltage on transformer.
HP Fault Code 2 High Pressure		X	Reduced or no water flow in cooling	Check pump operation or valve operation/setting. Check water flow adjust to proper flow rate.
		X	Water Temperature out of range in cooling	Bring water temp within design parameters.
	X		Reduced or no airflow in heating	Check for dirty air filter and clean or replace.
				Check fan motor operation and airflow restrictions.
				Dirty Air Coil - construction dust etc.
		X	Air temperature out of range in heating	Bring return air temp within design parameters.
	X	X	Overcharged with refrigerant	Check superheat/subcooling vs typical operating condition table.
X	X	Bad HP Switch	Check switch continuity and operation. Replace.	
LP/LOC Fault Code 3	X	X	Insufficient charge	Check for refrigerant leaks.
Low Pressure / Loss of Charge	X		Compressor pump down at start-up	Check charge and start-up water flow.
LT1 Fault Code 4 Water coil low temperature limit	X		Reduced or no water flow in heating	Check pump operation or water valve operation/setting.
				Plugged strainer or filter? Clean or replace.
				Check water flow. Adjust to proper flow rate.
	X		Inadequate antifreeze level	Check antifreeze density with hydrometer.
	X		Improper temperature limit setting (30°F vs 10°F [-1°C vs -2°C])	Clip JW3 jumper for antifreeze (10°F [-12°C]) use.
X		Water Temperature out of range	Bring water temp within design parameters.	
LT2 Fault Code 5 Air coil low temperature limit		X	Reduced or no airflow in cooling	Check for dirty air filter and clean or replace. Check fan motor operation and airflow restrictions. Too high of external static? Check static vs blower table.
		X	Air Temperature out of range	Too much cold vent air? Bring entering air temp within design parameters.
	X		Improper temperature limit setting (30°F vs 10°F [-1°C vs -12°C])	Normal air-side applications will require 30°F [-1°C] only.
	X	X	Bad thermistor	Check temp and impedance correlation per chart.
	Condensate Fault Code 6	X	X	Blocked drain
X		X	Improper trap	Check trap dimensions and location ahead of vent.
		X	Poor drainage	Check for piping slope away from unit.
				Check slope of unit toward outlet.
				Poor venting? Check vent location.
		X	Moisture on sensor	Check for moisture shorting to air coil.
X		X	Plugged air filter	Replace air filter.
X	X	Restricted Return Airflow	Find and eliminate restriction. Increase return duct and/or grille size.	

Table continued on next page.

Models:
SB
072-300

Functional Troubleshooting

Table continued from previous page.

Fault	Htg	Clg	Possible Cause	Solution
Over/Under Voltage Code 7 (Auto resetting)	X	X	Under Voltage	Check power supply and 24VAC voltage before and during operation.
				Check power supply wire size.
	X	X	Over Voltage	Check compressor starting. Need hard start kit?
				Check 24VAC and unit transformer. Tap for correct power supply voltage.
Unit Performance Sentinel Code 8	X		Heating mode LT2>125°F [52°C]	Check for poor airflow or overcharged unit.
		X	Cooling Mode LT1>125°F [52°C] OR LT2< 40°F [4°C]	Check for poor water flow or airflow.
Swapped Thermistor Code 9	X	X	LT1 and LT2 swapped	Reverse position of thermistors
Refrigerant and RDS Code 15	X	X	Refrigerant Leak	Check refrigerant charge. If the charge is low, identify and repair the leak.
			Faulty RDS sensor	Check refrigerant charge. If the charge is not low, replace the RDS sensor.
No Fault Code Shown	X	X	No compressor operation	See "Only Fan Operates".
	X	X	Compressor overload	Check and replace, if necessary.
	X	X	Control board	Reset power and check operation.
Unit Short Cycles	X	X	Dirty air filter	Check and clean air filter.
	X	X	Unit in "test mode"	Reset power or wait 20 minutes for auto exit.
	X	X	Unit selection	Unit may be oversized for space. Check sizing for actual load of space.
	X	X	Compressor overload	Check and replace, if necessary.
Only Fan Runs	X	X	Thermostat position	Ensure thermostat set for heating or cooling operation.
	X	X	Unit locked out	Check for lockout codes. Reset power.
	X	X	Compressor Overload	Check compressor overload. Replace if necessary.
	X	X	Thermostat wiring	Check thermostat wiring at heat pump. Jumper Y and R for compressor operation in test mode.
Only Compressor Runs	X	X	Thermostat wiring	Check G wiring at heat pump. Jumper G and R for fan operation.
	X	X		Check thermostat wiring at heat pump. Jumper Y and R for compressor operation in test mode.
	X	X	Fan motor relay	Jumper G and R for fan operation. Check for line voltage across BR contacts.
	X	X	Fan motor	Check fan power enable relay operation (if present).
	X	X		Check for line voltage at motor. Check capacitor.
Unit Doesn't Operate in Cooling		X	Reversing valve	Set for cooling demand and check 24VAC on RV coil and at CXM2. If RV is stuck, run high pressure up by reducing water flow and while operating engage and disengage RV coil voltage to push valve.
		X		Thermostat setup
		X	Thermostat wiring	Check O wiring at heat pump. Jumper O and R for RV coil 'click'.
		X		Put thermostat in cooling mode. Check 24VAC on O (check between C and O); check for 24VAC on W (check between W and C). There should be voltage on O, but not on W. If voltage is present on W, thermostat may be bad or wired incorrectly.
		X		

Performance Troubleshooting

Models:
SB
072-300

Symptom	Htg	Clg	Possible Cause	Solution
Insufficient capacity/ Not cooling or heating	X	X	Dirty filter	Replace or clean.
	X		Reduced or no airflow in heating	Check for dirty air filter and clean or replace.
				Check fan motor operation and airflow restrictions.
				Too high of external static? Check static vs. blower table.
		X	Reduced or no airflow in cooling	Check for dirty air filter and clean or replace.
				Check fan motor operation and airflow restrictions.
				Too high of external static? Check static vs. blower table.
	X	X	Leaky duct work	Check supply and return air temperatures at the unit and at distant duct registers. If significantly different, duct leaks are present.
	X	X	Low refrigerant charge	Check superheat and subcooling per chart.
	X	X	Restricted metering device	Check superheat and subcooling per chart. Replace.
	X	Defective reversing valve	Perform RV touch test.	
X	X	Thermostat improperly located	Check location and for air drafts behind stat.	
X	X	Unit undersized	Recheck loads & sizing. Check sensible cooling load and heat pump capacity.	
X	X	Scaling in water heat exchanger	Perform scaling check and clean if necessary.	
X	X	Inlet water too hot or cold	Check load, loop sizing, loop backfill, ground moisture.	
High Head Pressure	X		Reduced or no airflow in heating	Check for dirty air filter and clean or replace.
				Check fan motor operation and airflow restrictions.
				Too high of external static? Check static vs. blower table.
		X	Reduced or no water flow in cooling	Check pump operation or valve operation/setting. Check water flow. Adjust to proper flow rate.
		X	Inlet water too hot	Check load, loop sizing, loop backfill, ground moisture.
	X		Air temperature out of range in heating	Bring return air temperature within design parameters.
		X	Scaling in water heat exchanger	Perform scaling check and clean if necessary.
	X	X	Unit overcharged	Check superheat and subcooling. Re-weigh in charge.
X	X	Non-condensables in system	Vacuum system and re-weigh in charge.	
X	X	Restricted metering device	Check superheat and subcooling per chart. Replace.	
Low Suction Pressure	X		Reduced water flow in heating	Check pump operation or water valve operation/setting.
				Plugged strainer or filter? Clean or replace.
				Check water flow. Adjust to proper flow rate.
	X		Water temperature out of range	Bring water temperature within design parameters.
		X	Reduced airflow in cooling	Check for dirty air filter and clean or replace.
				Check fan motor operation and airflow restrictions.
Too high of external static? Check static vs. blower table.				
	X	Air temperature out of range	Too much cold vent air? Bring entering air temperature within design parameters.	
X	X	Insufficient charge	Check for refrigerant leaks.	

Table continued on next page.

Models:
SB
072-300

Performance Troubleshooting

Table continued from previous page.

Symptom	Htg	Clg	Possible Cause	Solution
Low Discharge Air Temperature in Heating	X		Too high of airflow	Check fan motor speed selection and airflow chart.
	X		Poor performance	See 'Insufficient Capacity'
High humidity		X	Too high of airflow	Check fan motor speed selection and airflow chart.
		X	Unit oversized	Recheck loads & sizing. Check sensible cooling load and heat pump capacity.
Only Compressor Runs	X	X	Thermostat wiring	Check G wiring at heat pump. Jumper G and R for fan operation.
	X	X	Fan motor relay	Jumper G and R for fan operation. Check for line voltage across blower relay contacts. Check fan power. Enable relay operation (if present).
	X	X	Fan motor	Check for line voltage at motor. Check capacitor.
	X	X	Thermostat wiring	Check thermostat wiring at CXM2. Put in Test Mode and then jumper Y1 and W1 to R to give call for fan, compressor and electric heat.
Unit Doesn't Operate in Cooling		X	Reversing valve	Set for cooling demand and check 24VAC on RV coil. If RV is stuck, run high pressure up by reducing water flow and, while operating, engage and disengage RV coil voltage to push valve.
		X	Thermostat setup	Check for "O" RV setup, not "B".
		X	Thermostat wiring	Check O wiring at heat pump. CXM2 requires call for compressor. You should hear a "click" sound from the reversing valve.
Modulating Valve Troubleshooting	X	X	Improper output setting	Verify the AO-2 jumper is in the 0-10V position.
	X	X	No valve output signal	Check DC voltage between AO2 and GND. Should be 0 when valve is off and between 3.3V and 10V when valve is on.
	X	X	No valve operation	Check voltage to the valve. Replace valve if voltage and control signals are present at the valve and it does not operate.

Functional Troubleshooting Form

Water-to-Air Units

Customer: _____ Loop Type: _____ Startup Date: _____

Model #: _____ Serial #: _____ Antifreeze Type & %: _____

Complaint: _____

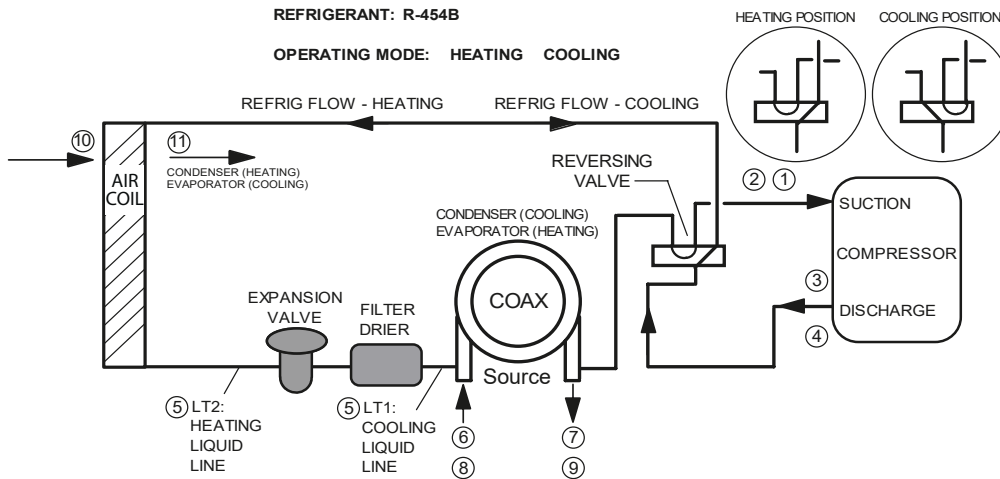

Description	Heating	Cooling	Notes
Voltage			
Compressor Amps			
1 Suction Temp			
2 Suction Press			
2a Saturation Temp			
2b Superheat			
3 Discharge Temp			
4 Discharge Press			
4a Saturation Temp			
4b Subcooling			
5 Liquid Line Temp			
6 Source Water In Tmp			
7 Source Water Out Tmp			Temp Diff. =
8 Source Water In Pres			
9 Source Water Out Pres			
9a Press Drop			
9b Flow Rate			
10 Return Air Temp			
11 Supply Air Temp			

Heat of Extraction (Absorption) or Heat of Rejection:

Fluid Factor: (for Btuh)
500 (Water); 485 (Antifreeze)

Fluid Factor: (for kW)
4.18 (Water); 4.05 (Antifreeze)

HE or HR =

_____ Flow Rate x _____ Temp. Diff x _____ Fluid Factor

Superheat = Suction temperature - suction saturation temp. = _____ (deg F)

Subcooling = Discharge saturation temp. - liquid line temp. = _____ (deg F)

NOTE: Never connect refrigerant gauges during startup procedures. Conduct water-side analysis using P/T ports to determine water flow and temperature difference. If water-side analysis shows poor performance, refrigerant troubleshooting may be required. Connect refrigerant gauges as a last resort.

Models:
SB
072-300

Warranty (U.S. & Canada)

CLIMATE MASTER, INC. LIMITED EXPRESS WARRANTY/ LIMITATION OF REMEDIES AND LIABILITY



It is expressly understood that unless a statement is specifically identified as a warranty, statements made by Climate Master, Inc., a Delaware corporation, ("CM") or its representatives, relating to CM's products, whether oral, written or contained in any sales literature, catalog or any other agreement, are not express warranties and do not form a part of the basis of the bargain, but are merely CM's opinion or commendation of CM's products.

EXCEPT AS SPECIFICALLY SET FORTH HEREIN, THERE IS NO EXPRESS WARRANTY AS TO ANY OF CM'S PRODUCTS. CM MAKES NO WARRANTY AGAINST LATENT DEFECTS. CM MAKES NO WARRANTY OF MERCHANTABILITY OF THE GOODS OR OF THE FITNESS OF THE GOODS FOR ANY PARTICULAR PURPOSE.

GRANT OF LIMITED EXPRESS WARRANTY

CM warrants that the products purchased and related to the United States of America and Canada to be free from defects in material and workmanship under normal use and maintenance as follows: (1) All complete air conditioning systems shall be warranted for 18 months or 1800 hours of operation, whichever is first; (2) Refrigerant parts shall be warranted for 18 months or 1800 hours of operation, whichever is first; (3) Parts which are supplied under warranty for ninety (90) days from date of shipment (from factory). All parts must be returned to CM's factory in Oklahoma City, Oklahoma, freight prepaid, no later than sixty (60) days after the date of the failure of the part; if CM determines the part to be defective and within CM's Limited Express Warranty, CM shall, when such part has been either replaced or repaired, return such a factory recognized dealer, contractor or service organization, F.O.B. CM's factory, Oklahoma City, Oklahoma, freight prepaid. The warranty on any parts repaired or replaced under warranty expires at the end of the original warranty period.

This warranty does not cover and does not apply to: (1) Air filters, fuses, refrigerant, fluids, oil; (2) Products relocated after initial installation; (3) Any portion or component of any system that is not supplied by CM, regardless of the cause of the failure of such portion or component; (4) Products on which the unit identification tags or labels have been removed or defaced; (5) Products on which payment to CM is or has been in default; (6) Products which have defects or damage which result from improper installation, wiring, electrical imbalance characteristics or maintenance; or are caused by accident, misuse or abuse, fire, flood, alteration or misapplication of the product; (7) Products which have defects or damage which result from a contaminated or corrosive air or liquid supply, operation at abnormal temperatures, or unauthorized opening of refrigerant circuit; (8) Mold, fungus or bacteria damages; (9) Products subjected to corrosion or abrasion; (10) Products manufactured or supplied by others; (11) Products which have been subjected to misuse, negligence or accidents; (12) Products which have been operated in a manner contrary to CM's printed instructions; or (13) Products which have defects, damage or insufficient performance as a result of insufficient or incorrect system design or the improper application of CM's products.

CM is not responsible for: (1) The costs of any fluids, refrigerant or other system components, or associated labor to repair or replace the same, which is incurred as a result of a defective part covered by CM's Limited Express Warranty; (2) The costs of labor, refrigerant, materials or service incurred in removal of the defective part, or in obtaining and replacing the new or repaired part; or (3) Transportation costs of the defective part from the installation site to CM or of the return of any part not covered by CM's Limited Express Warranty.

Limitations: This Limited Express Warranty is given in lieu of all other warranties. If, notwithstanding the disclaimers contained herein, it is determined that other warranties exist, any such warranties, including without limitation any express warranties or any implied warranties of fitness for particular purpose and merchantability, shall be limited to the duration of the Limited Express Warranty.

LIMITATION OF REMEDIES

In the event of a breach of the Limited Express Warranty, CM will only be obligated at CM's option to repair, the failed part or unit or to furnish a new or rebuilt part or unit in exchange for the part or unit which has failed. If after written notice to CM's factory in Oklahoma City, Oklahoma of each defect, malfunction or other failure and a reasonable number of attempts by CM to correct the defect, mal function or other failure and the remedy fails of its essential purpose, CM shall refund the purchase price paid to CM in exchange for the return of the sold goods. Said refund shall be the maximum liability of CM. **THIS REMEDY IS THE SOLE AND EXCLUSIVE REMEDY OF THE BUYER FOR THEIR PURCHASER AGAINST CM FOR BREACH OF CONTRACT, FOR THE BREACH OF ANY WARRANTY OR FOR THE BREACH OF ANY STRICT LIABILITY.**

LIMITATION OF LIABILITY

CM shall have no liability for any damages if CM's performance is delayed for any reason or is prevented to any extent by any event such as, but not limited to, any war, civil unrest, government restrictions or restraints, strikes or delays of any kind, or other causes beyond CM's control. **CM'S LIABILITY IS LIMITED TO THE PURCHASE PRICE OF THE DEFECTIVE PART OR UNIT. CM MAKES NO WARRANTY OF MERCHANTABILITY FOR CONSEQUENTIAL DAMAGE IN CONTRACT, FOR BREACH OF ANY EXPRESS OR IMPLIED WARRANTY, OR IN TORT, WHETHER FOR CM'S NEGLIGENCE OR AS STRICT LIABILITY.**

OBTAINING WARRANTY PERFORMANCE

Normally, the contractor or service organization who installed the products will provide warranty performance for the owner. Should the installer be unavailable, contact any CM recognized dealer, contractor or service organization. If assistance is required in obtaining warranty performance, write or call:

Climate Master, Inc. • Customer Service • 7300 S.W. 44th Street • Oklahoma City, Oklahoma 73179 (405) 745-6000

NOTE: Some states or Canadian provinces do not allow limitations on how long an implied warranty lasts, or the limitation or exclusions of consequential or incidental damages, so the foregoing exclusions and limitations may not apply to you. This warranty gives you specific legal rights, and you may also have other rights which vary from state to state and from Canadian province to Canadian province.

Please refer to the CM Installation, Operation and Maintenance Manual for operating and maintenance instructions.

Rev: 11/09



Warranty (International)

CLIMATE MASTER, INC. LIMITED EXPRESS WARRANTY / LIMITATION OF REMEDIES AND LIABILITY (FOR INTERNATIONAL CLASS PRODUCTS)



Climate Master, Inc. is specifically identified as a warranty, statements made by Climate Master, Inc., a Delaware corporation, U.S.A. ("CM") or its representatives, relating to CM's products, whether oral, written or contained in any sales literature, catalog, this or any other agreement or other materials, are not express warranties and do not form a part of the basis of the bargain, but are merely CM's opinion or commendation of CM's products. **EXCEPT AS SPECIFICALLY SET FORTH HEREIN AND TO THE FULLEST EXTENT PERMITTED BY APPLICABLE LAW, CM MAKES NO WARRANTY AS TO ANY OF CM'S PRODUCTS, AND CM MAKES NO WARRANTY AGAINST LATENT DEFECTS OR ANY MERCHANTABILITY OF THE GOODS OR OF THE FITNESS OF THE GOODS FOR ANY PARTICULAR PURPOSE.**

GRANT OF LIMITED EXPRESS WARRANTY

CM warrants CM products purchased and installed outside the United States of America ("U.S.A.") and Canada to be free from material defects in materials and workmanship under normal use and maintenance as follows: (1) All complete air conditioning, heating or heat pump units built or sold by CM for twelve (12) months from date of unit start-up or eighteen (18) months from date of shipment (from CM's factory), whichever comes first; and, (2) Repair and replacement parts, which are not supplied under warranty, for ninety (90) days from date of shipment (from factory).

Warranty parts shall be furnished by CM if ordered through an authorized sales representative of CM ("Representative") within sixty (60) days after the failure of the part. If CM determines that a parts order qualifies for replacement under CM's warranty, such parts shall be shipped. Freight prepaid to the Representative or the ultimate user, as requested by Representative. All duties, taxes and other fees shall be paid by the ultimate user through the Representative.

If requested by CM, all defective parts shall be returned to CM's factory in Oklahoma City, Oklahoma, U.S.A., freight and duty prepaid, not later than sixty (60) days after the date of the request. If the defective part is not timely returned or if CM determines the part to not be defective or otherwise not to qualify under CM's Limited Express Warranty, CM shall invoice Customer the costs for the parts furnished, including freight. The warranty on any part repaired or replaced under warranty expires at the end of the original warranty period.

This warranty does not cover and does not apply to: (1) Air filters, fuses, refrigerant, fluids, oil; (2) Products relocated after initial installation; (3) Any portion or component of any system that is not supplied by CM, regardless of the cause of the failure of such portion or component; (4) Products for which the unit identification labels have been removed or defaced; (5) Products on which the Customer, CM's distributor, Representative, or the Customer's installer is in default; (6) Products which have defects or damage which result from improper installation, wiring, electrical imbalance characteristics or maintenance, or from parts or components manufactured by others or are caused by accident, misuse, negligence, abuse, fire, flood, lightning, alteration or misapplication of the product; (7) Products which have defects or damage which result from a contaminated or corrosive air or liquid supply, operation at abnormal temperatures or flow rates, or unauthorized opening of the refrigerant circuit; (8) Mold, fungus or bacteria damage; (9) Products subjected to corrosion or abrasion; (10) Products, parts or components manufactured or supplied by others; (11) Products which have been subjected to misuse, negligence or accidents; (12) Products which have been operated in a manner contrary to CM's printed instructions; (13) Products which have defects, damage or insufficient performance as a result of insufficient or incorrect system design or the improper application, installation, or use of CM's products; or (14) Electricity or fuel costs, or any increases or unrealized savings in same, for any reason.

CM is not responsible for: (1) The cost of any fluids, refrigerant or other system components, or the associated labor to repair or replace the same, which is incurred as a result of a defective part covered by CM's Limited Express Warranty; (2) The cost of labor, refrigerant, materials or service incurred in diagnosis and removal of the defective part, or in obtaining and replacing the new or repaired part; (3) Transportation costs of the defective part from the installation site to CM or of the return of any part not covered by CM's Limited Express Warranty; or (4) The costs of normal maintenance.

Limitation: This Limited Express Warranty is given in lieu of all other warranties. If, notwithstanding the disclaimers contained herein, it is determined by a court or other qualified judicial body that other warranties exist, any such warranty, including without limitation any express warranty or any implied warranty of fitness for particular purpose and merchantability, shall be limited to the duration of the Limited Express Warranty. This Limited Express Warranty does not exclude any warranty that is mandatory and that may not be excluded under applicable impetative law.

LIMITATION OF REMEDIES

In the event of a breach of this Limited Express Warranty or any warranty that is mandatory under applicable impetative law, CM will only be obligated at CM's option to either repair the failed part or unit or to furnish a new or rebuilt part or unit in exchange for the part or unit which has failed. If after written notice to CM's factory in Oklahoma City, Oklahoma, U.S.A. of each defect, malfunction or other failure and a reasonable number of attempts by CM to correct the defect, malfunction or other failure and the remedy fails of its essential purpose, CM shall refund the purchase price paid to CM in exchange for the return of the sold good(s). Said refund shall be the maximum liability of CM. **TO THE FULLEST EXTENT PERMITTED BY APPLICABLE LAW, THIS REMEDY IS THE SOLE AND EXCLUSIVE REMEDY OF THE CUSTOMER AGAINST CM FOR BREACH OF CONTRACT, FOR THE BREACH OF ANY WARRANTY OR FOR CM'S NEGLIGENCE OR IN STRICT LIABILITY.**

LIMITATION OF LIABILITY

CM shall have no liability for any damages if CM's performance is delayed for any reason or is prevented to any extent by any event such as, but not limited to: any war, civil unrest, government restrictions or restraints, strikes, or work stoppages, fire, flood, accident, allocation, shortages of transportation, fuel, materials, or labor, acts of God or any other reason beyond the sole control of CM. **TO THE FULLEST EXTENT PERMITTED BY APPLICABLE LAW AND SUBJECT TO THE NEXT SENTENCE, CM EXPRESSLY DISCLAIMS AND EXCLUDES ANY LIABILITY FOR LOSS OF PROFITS, LOSS OF BUSINESS OR GOODWILL, CONSEQUENTIAL, INCIDENTAL, SPECIAL, LIQUIDATED, OR PUNITIVE DAMAGE IN CONTRACT, FOR BREACH OF ANY EXPRESS OR IMPLIED WARRANTY, OR IN TORT, WHETHER FOR CM'S NEGLIGENCE OR AS STRICT LIABILITY.** Nothing in this Agreement is intended to exclude CM's liability for death, personal injury or fraud.

OBTAINING WARRANTY PERFORMANCE

Normally, the contractor or service organization who installed the products will provide warranty performance for the owner. Should the installer be unavailable, contact any CM recognized Representative. If assistance is required in obtaining warranty performance, write or call:

Climate Master, Inc. • Customer Service • 7300 S.W. 44th Street • Oklahoma City, Oklahoma, U.S.A. 73179 • (405) 745-6000 • FAX (405) 745-6068

NOTE: Some countries do not allow limitations on how long an implied warranty lasts, or the limitation or exclusions of consequential or incidental damages, so the foregoing exclusions and limitations may not apply to you. This warranty gives you specific legal rights, and you may also have other rights which vary from state to state and country to country.

Please refer to the CM Installation, Operation and Maintenance Manual for operating and maintenance instructions.



Created: 10/09

Models:
SB
072-300

Notes

Notes

Models:
SB
072-300

Models:
SB
072-300

Revision History

Date	Section	Description
12/19/24	WSE Diagrams, Data, and Dimensions	Updated and rearranged preliminary WSE data, copy, and drawings with official content.
	Physical Data	Added blower horsepower data.
	Dimensional Data	Corrected flange and water connection measurements. Standardized electrical knockout data.
	Minimum Installation Area	Updated data. Removed unnecessary tables.
	Horizontal Installation	Changed "Duct Installation" page header to "Horizontal Installation"
	Field Conversion of Water Connections	Added note and graphic to clarify water connection directionality
	Performance Troubleshooting Guide	Removed mention of DXM2.5
	VFD, Functional Troubleshooting Guide, Performance Troubleshooting Guide	Reformatted
	Unit Startup Procedure	Added Motorized Water Valve and Modulating Valve adders and Water Pressure Drop tables.
10/22/24	Attentions, Cautions, and Warnings	Added additional notices concerning safety, installation, and RDS procedures.
	Model Nomenclature	Updated Voltage, Blower Motor, and Water Options offerings.
	General Information	Updated Altitude Adjustment table. Added note concerning maximum installation altitude.
	Physical Data	Updated data.
	Dimensional Data	Updated standard configuration dimensional data and reference graphics.
	Horizontal and Vertical Installation	Added note concerning minimum clearances.
	Electrical	Updated data. Updated disconnect switch requirements. Removed content not applicable to the SB unit. Added diagrams for external pump control applications.
	Unit Operating Conditions	Updated from rated to recorded data.
	Blower Performance Data	Updated data. Added note concerning maximum allowable altitude of installation.
	Electrical Data	Updated Electrical Data.
	Operating and Commissioning Conditions	Updated maximum working water pressure.
07/30/24	Operating and Commissioning Limits	Updated Unit Maximum Water Working Pressure
	Attentions, Cautions, and Warnings;	Added attentions concerning installation
	Refrigerant System Servicing	Added decommissioning instructions
	Electrical	Added electrical disconnect information



A NIBE GROUP MEMBER

7300 SW 44th St | Oklahoma City, OK 73179
Phone: 800.299.9747
www.climatemaster.com



ClimateMaster works continually to improve its products. As a result, the design and specifications of each product at the time of order may be changed without notice and may not be as described herein. Please contact ClimateMaster's Customer Service Department at 800-299-9747 for specific information on the current design and specifications. Statements and other information contained herein are not express warranties and do not form the basis of any bargain between the parties, but are merely ClimateMaster's opinion or commendation of its products. The latest version of this document is available at www.climatemaster.com.

Engineered and assembled in the USA.

© ClimateMaster, Inc. All Rights Reserved 2024