



CLIMATEMASTER® *Flow Controller*

GEOTHERMAL PUMPING MODULE

INSTALLED BY:

Flow Controller

Installation, Operation & Maintenance Instructions

7/97

TABLE OF CONTENTS

Flow Controller Description	2
Flow Controller Mounting	2
Piping Installation	3
Electrical Wiring	4
Flushing the Earth Loop	5
Antifreeze Selection	6
Antifreeze Charging	7
Heat Pump Freezestat Setting	8
Pressure Drop Tables	9
Earth Loop Pressurization	9
Flow Controller Start-Up	10
Pump Cartridge Replacement	10
Closed Loop Design	11
Polyethylene Pressure Drop	14
Rubber Hose Pressure Drop	15
Closed Loop Installation	16
Building Entry	18

FLOW CONTROLLER DESCRIPTION

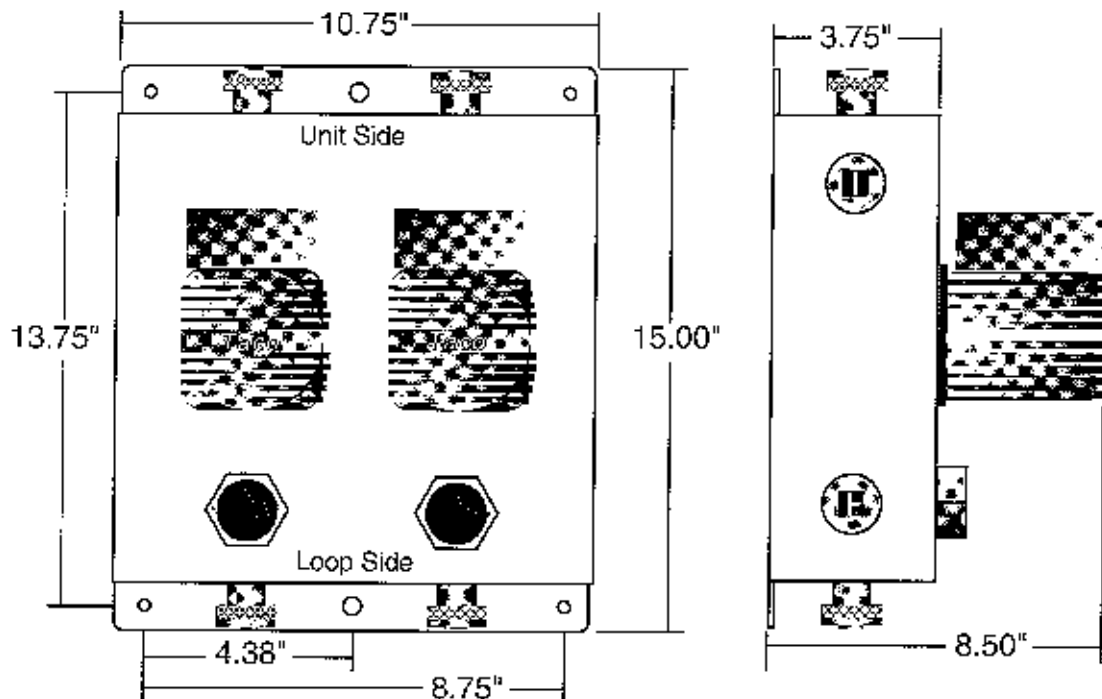

Figure 1 - Flow Controller Dimensions

The AFCS1 and 2 are insulated flow controllers containing all flush, fill, and isolation connections for a residential and light commercial geothermal closed loop system that require a flow rate of no more than 20 gpm. The AFCS1 and 2 are equipped with a large bore 1 1/4" FPT swivel fittings for both earth loop and heat pump unit connections. Either 1 (AFCS1) or 2 (AFCS2) Taco 0013

chilled water rated cartridge type circulators are included with the flow controller. Included in this kit are:

- 2 Lag bolts for mounting AFC onto stud walls
- 4 Self drilling sheet metal screws for mounting AFC onto heat pump
- 2 1" MPT PVC plug for sealing flush ports after installation

FLOW CONTROLLER MOUNTING

General

The installation of the ClimateMaster Flow Controller shall be made in accordance with all applicable codes.

Mounting the Flow Controller

The flow controller should be located as close to the unit as possible to limit the length of rubber hose kit and thus its associated pressure drop. In general the flow controller can be mounted in any orientation with the exception of when the pump shafts are in a vertical position as when it is laid flat on the floor or any similar position. The controller is typically mounted in one of three locations. Be certain there is adequate access to all required flush ports and valves before mounting.

Stud Wall - Mounting on stud wall with or without drywall can be accomplished by using the two supplied lag bolts through the top and bottom center holes directly into the studs as shown in Figure 2.

Self drilling screws into sheet metal 4 places.
DO NOT PUNCTURE INTERNAL COMPONENTS!

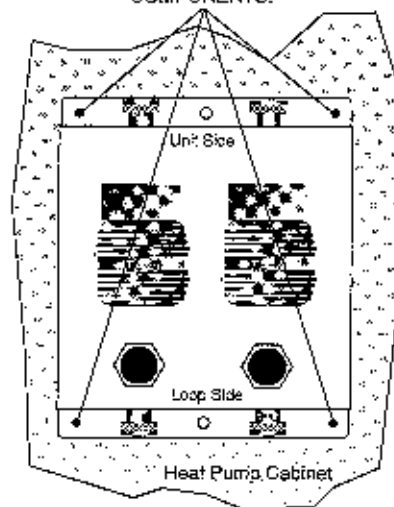

Figure 2 - Mounting Flow Controller on Stud Wall

Side of Unit - Mounting on the side of the unit can be accomplished by using the four self-drilling screws directly into the sheet metal access panels or cabinet as shown in Figure 3. Be careful not to puncture any internal piping or other components with the screws. *It should be remembered that heat pump access will be limited in this mounting position.*

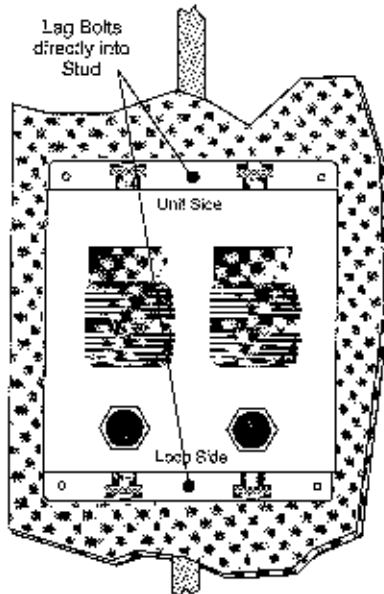

Figure 3 - Mounting Flow Controller on Side of Unit

Concrete wall - Mounting onto a concrete wall can be accomplished by using 4 1/4" 'Tapcon' screws (supplied by others) directly into the concrete wall.

Piping Installation

The Flow controller features 1/4" FPT swivel fittings for flexible and easy installation. Table 1 illustrates the connections options available for the AFCSI and 2. Avoid using 3/4" piping on flows greater than 6 gpm. Pressure drop in piping systems should be calculated to insure adequate flow through unit. **All piping should be insulated with closed cell insulation of 1/2" wall thickness.** Table 2 shows the insulation requirements for typical piping materials. Piping insulation should be glued and sealed to prevent condensation using closed cell insulation glue. **The swivel connectors on the flow controller are designed to be hand tightened only.**

Table 1 - AFCSI and 2 Connection Materials

To	Fittings
PVC	1-1/4" MPT x 1" PVC Glue Socket
PE Fusion	1-1/4" MPT x 1-1/4" PE Fusion
PE Barb	1-1/4" MPT x 1-1/4" insert barb*
Copper Sweat	1-1/4" MPT x 1" sweat**
Copper Thread	1-1/4" MPT x 1" MPT Nipple

* Use double all-stainless hose clamps

** Sweat before connecting to flow controller

Table 2 - Typical Piping Insulation Materials

Piping Material	Insul Description
1" Hose Kit	1-3/8" ID - 1/2" wall
1" IPS PE	1-1/4" ID - 1/2" wall
1-1/4" IPS PE	1-5/8" ID - 1/2" wall
2" IPS PE	2-3/8" ID - 1/2" wall

Loop side piping is typically polyethylene piping directly into the flow controller. Connection to the flow controller can be accomplished by a fusion to brass MPT adapter (GFMA66). In multiple flow controller systems such as multifamily housing, PVC can also be used on the loop side, remembering however that the transition from PVC to PE should be accomplished by a flange connection and PVC is approved for use only as an indoor piping material in earth loops.

Unit side piping is typically connected using the ClimateMaster hose kit (AHK5E) which contains all fittings necessary for connection between the flow controller and the unit as shown in Figure 5. In the AFCSI remove cover and make connections as shown in Figure 4 remembering all areas of the piping should be insulated to prevent condensation.

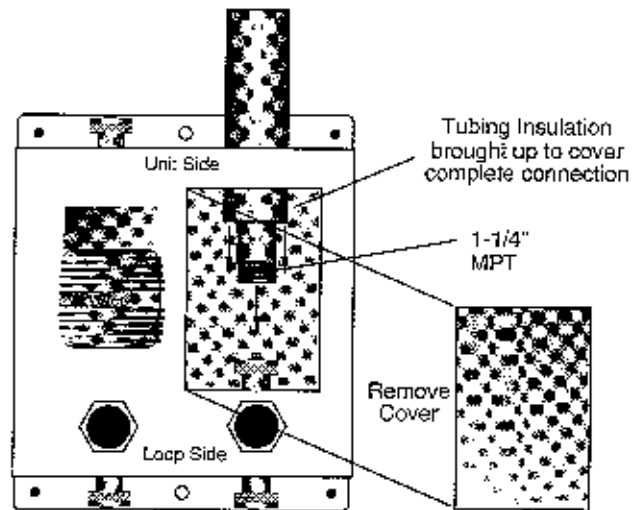

Figure 4 - AFCSI Piping Detail

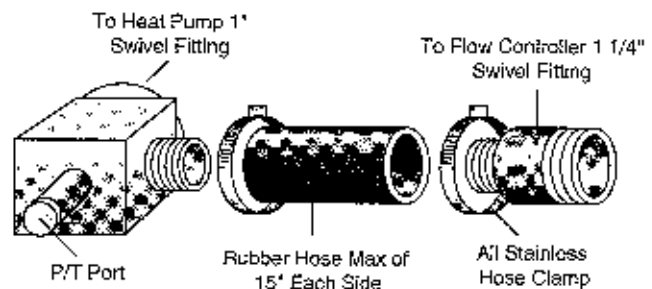

Figure 5 - AHK5E Hose Kit typical Detail

In multiple unit systems, PVC adapter's (1 1/4" MPT x PVC socket) to the flow controller and standard PVC piping materials can be used to 'tee' more than one unit into the flow controller. It is recommended that a hose kit still be used at the end of the PVC piping run to facilitate ease of installation and service of the units as shown in Figure 6. Insulate all exposed piping and plastic to metal threads should not be used due to their leakage potential.

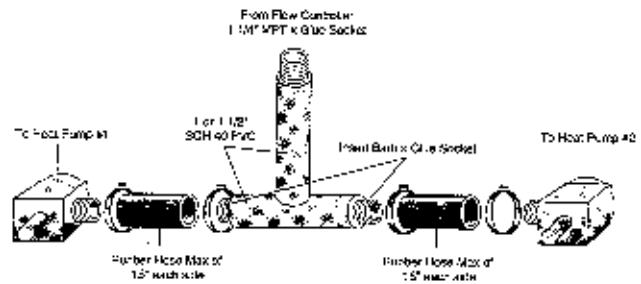

Figure 6 - Two Units Utilizing One Flow Controller (one side shown)

FLOW CONTROLLER ELECTRICAL WIRING

Power wiring to the flow controller should conform to all applicable codes. Figure 7 illustrates the wiring required for the Classic and Figure 8 for the Ultra Classic Series heat pumps. Note the flow controller is available in only in 230V single phase voltage. Pumps are fused through a pair of circuit breakers in the unit control boxes. See electrical table for flow controller characteristics.

Electrical Table

Model	Volts	Amps	HP
FCS1	230	1.23	1/6
FCS2	230	2.46	1/3

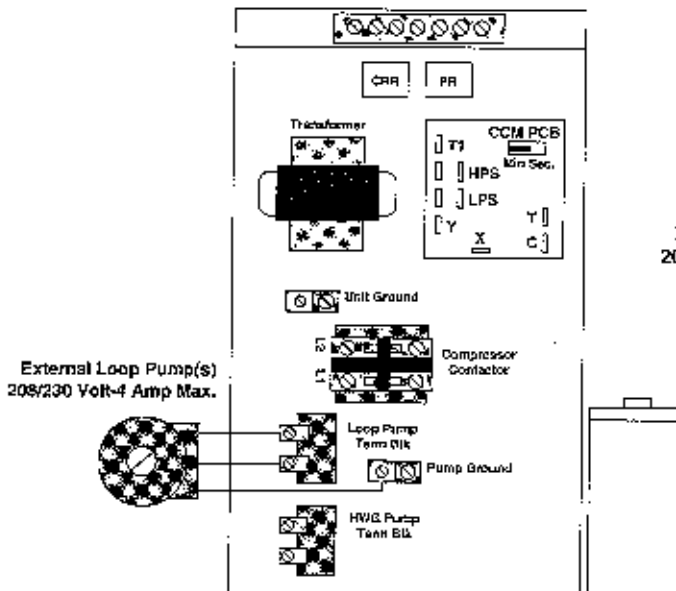

Figure 7 - Power Wiring to Classic Series

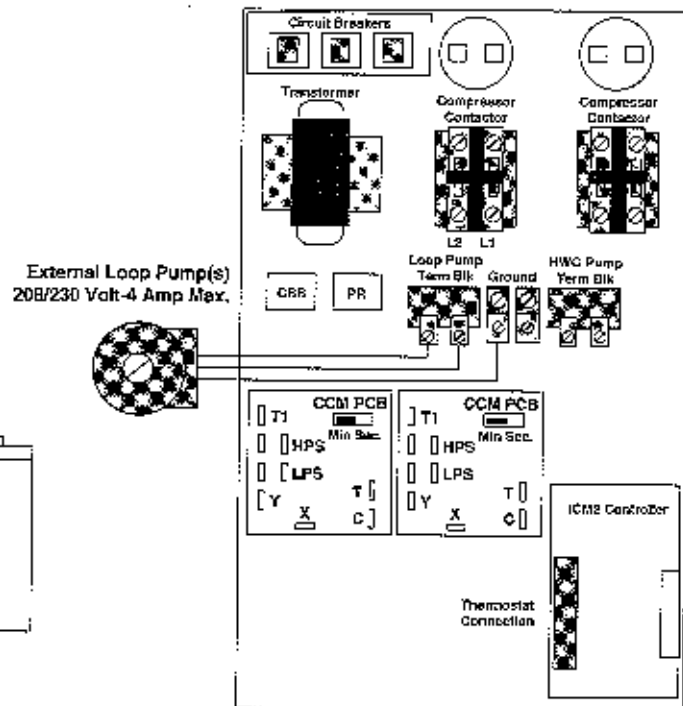

Figure 8 - Power Wiring to Ultra Classic Series

FLUSHING THE EARTH LOOP

Once piping is completed between the unit, flow controller and the ground loop, final purging and charging of the loop is needed.

A flush cart (at least a 1.5 hp pump) is needed to achieve adequate flow velocity in the loop to purge air and dirt particles from the loop itself. Antifreeze solution is used in most areas to prevent freezing. All air and debris must be removed from the earth loop piping system before operation. Flush the loop with a high volume of water at a high velocity (2 fps in all piping), both directions using a filter in the loop return line, of the flush cart to eliminate debris from the loop system. The steps below must be followed for proper flushing.

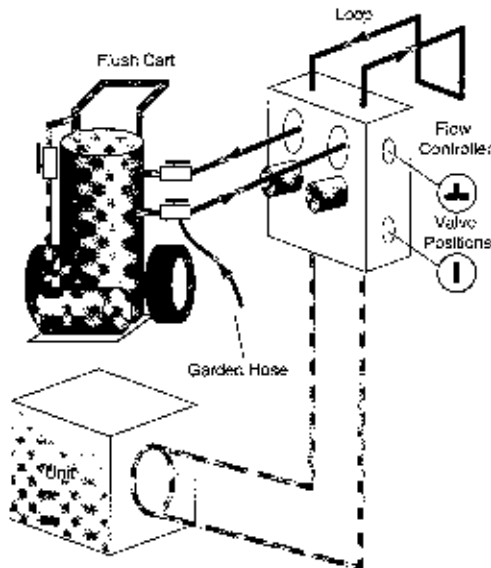

Figure 9A - Valve Position A - Loop Fill

Fill loop with water from a garden hose through flush cart before using flush cart pump to ensure an even fill and increase flushing speed. When water consistently returns back to the flush reservoir switch to valve position B.

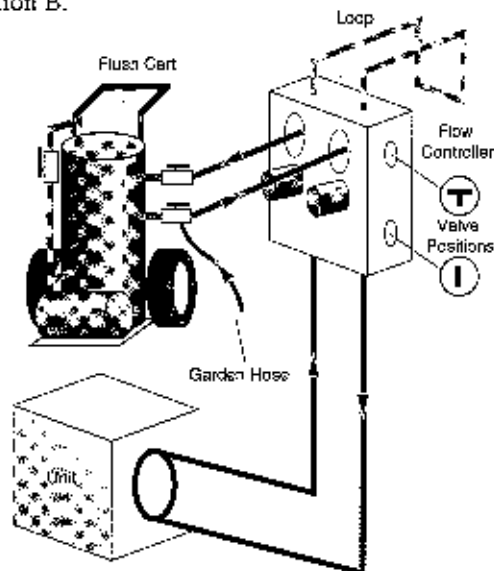

Figure 9B - Valve position B - Unit Fill

This position should be switched while filling to fill the unit heat exchanger and hose kit. This should be maintained until water consistently is returned into the flush reservoir.

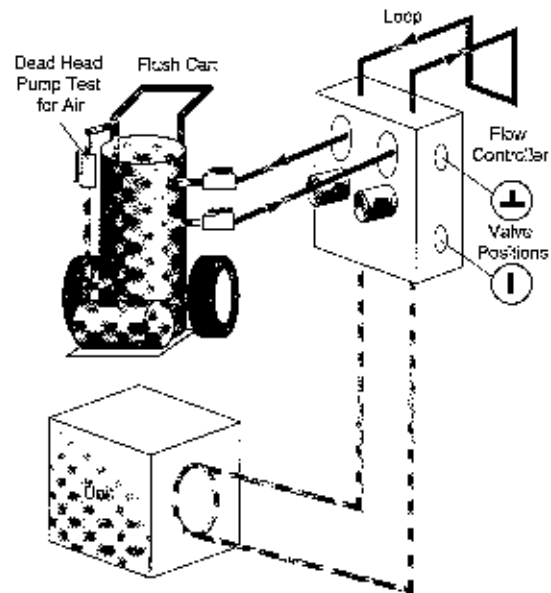

Figure 9C - Valve Position C - Loop Flush

Switch to valve position C. The supply water may be shut off and the flush cart turned on to begin flushing. Once the flush reservoir is full, do not allow the water level in the flush cart tank to drop below the pump inlet line or air can be pumped back out to the earth loop. Try to maintain a fluid level in the tank above the return tee so that air can not be continuously mixed back into the fluid. 50 psi surges can be used to help purge air pockets by simply shutting off the return valve going into the flush cart reservoir. This 'dead heads' the pump to 50 psi. To dead head the pump until maximum pumping pressure is reached, open the valve back up and a pressure surge will be sent through the loop to help purge air pockets from the piping system. Notice the drop in fluid level in the flush cart tank. **If all air is purged from the system, the level will drop only 1-2 inches in a 10" diameter PVC flush tank (about a half gallon) since liquids are incompressible.** If the level drops more than this, flushing should continue since air is still being compressed in the loop fluid. Do this a number of times. When the fluid level is dropping less than 1-2" in a 10" diameter tank the flow can be reversed.

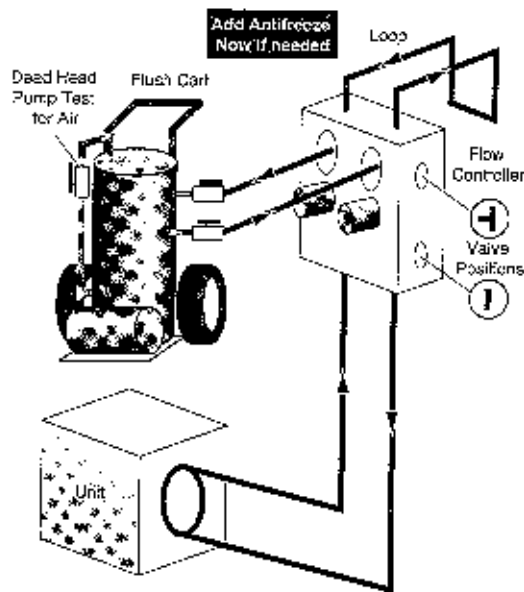

Figure 9D - Valve Position D - Full Flush

Now by switching both valves to this position water will flow both through the loop and the unit heat exchanger. Finally the dead head test should be checked again for an indication of air in the loop. **This fluid level drop is your only indication of air in the loop. Antifreeze may be added during this part of the flushing procedure see antifreeze section for details.**

Close the flush cart return valve and the after pressurizing close the flush cart supply valve to pressurize the loop to a static pressure at least 50 psi. If water pressure

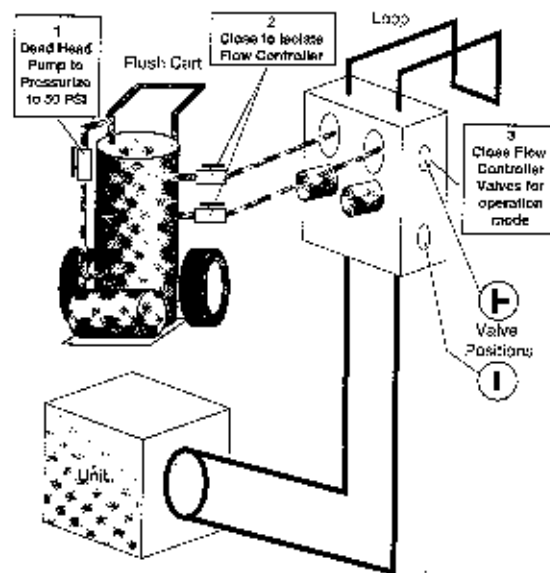

Figure 9E - Valve position E - Pressurize and Operation

is low use an air compressor to bump the pressure up through the P/T port. The loop may be isolated by moving to valve position E keeping watch on the pressure gauge of the flush cart for pressure greater than 50 psi. Loop static pressure will fluctuate with the seasons and pressures will be higher in the winter months than during the cooling season. This fluctuation is normal and should be considered when charging the system initially. Unhook flush cart from the flow controller. Install counter sink plugs using sealant compatible with PVC.

ANTIFREEZE SELECTION

General

In areas where minimum entering loop temperatures drop below 40°F or where piping will be routed through areas subject to freezing, antifreeze is needed. Alcohols and glycols are commonly used as antifreezes, however your local representative should be consulted for the antifreeze best suited to your area. Freeze protection should be maintained to 15°F below the lowest expected entering loop temperature. For example, if 30°F is the minimum expected entering loop temperature, the leaving loop temperature would be 25-22°F and freeze protection should be at 15°F (30°F-15°F=15°F). All alcohol's should be premixed and pumped from a reservoir outside of the building when possible or introduced under water level to prevent fuming. Initially calculate the total volume of fluid in the piping system using Table 3. Then use the percentage by volume shown in Table 4 for the amount of antifreeze. Antifreeze concentration should be checked from a well mixed sample using a hydrometer to measure specific gravity.

Antifreeze Characteristics

Selection of the antifreeze solution for ClimateMaster closed loop earth coupled systems requires the consideration of many important factors which have long-term implications on the performance and life of the equipment. Each area of concern leads to a different "best choice" of antifreeze. *The fact is that there is no "ideal" antifreeze and any choice will require compromises in one area or another.* Some of the factors to consider are safety, thermal performance, corrosiveness, local codes, stability, convenience, and cost.

Methanol - Methanol or wood alcohol is considered toxic in any form, good heat transfer, low to mid price, flammable in concentrations greater than 25%, non-corrosive, and low viscosity. Methanol has delivered outstanding performance in earth loops for over 10 years. Its' only drawbacks are toxicity and flammability. Although methanol enjoys widespread consumer use as a windshield washer fluid in even higher concentrations,

some local codes may limit its' use in earth loops. To increase safety, a premixed form should be used on the jobsite to increase the safety factor. Pure methanol can be purchased from any chemical supplier.

Ethanol - Ethanol or grain alcohol exhibits good heat transfer (slightly less than methanol), higher price, and is flammable in concentrations greater than 10%. Ethanol is generally non-corrosive and has medium viscosity. Ethanol in its pure form is considered nontoxic and shows promise as a geothermal heat transfer fluid, however the U.S. Bureau of Alcohol, Tobacco, and Firearms (ATF) limit its' distribution. All non-beverage ethanol is required to be denatured and rendered unfit to drink. Generally this is done by adding a small percentage of toxic substances such as methanol, benzene, or gasoline as a denaturant. Many of these denaturants are difficult to identify by the casual user and many are not compatible with polyethylene pipe. Only denatured ethanol can be purchased for commercial use. CM does not recommend the use of ethanol because of the unknown denaturants included and their possible toxicity and damage resulting to polyethylene piping systems.

Ethylene glycol - Generally non-corrosive, expensive, medium heat transfer, however is considered toxic. Its toxicity has prevented its widespread use in the ground source industry in spite of its widespread use in traditional watersource heat pump applications. CM does not currently recommend ethylene glycol as a ground source antifreeze.

Propylene glycol - Nontoxic, non-corrosive, expensive, hard to handle when cold, poorest heat transfer, has formed "slime-type" coatings inside pipe. Poor heat transfer has required its removal in some systems. Propylene glycol (PG) is acceptable in systems anticipating loops temperatures no colder than 40°F. these systems typically are antifreeze because of ambient conditions (outside plumbing or cooling tower, etc.). When loop temperatures are below 40°F the fluid becomes very difficult to pump and heat transfer characteristics suffer greatly. CM recommends only food grade propylene glycol be used to prevent the corrosion inhibitors (often present in other mixtures) from reacting with local water and 'coming' out of solution to form slime type coatings inside heat exchangers and thus hinder heat transfer.

GS4 (Potassium acetate) - Nontoxic, good heat transfer, high price, non-corrosive with added inhibitors, low viscosity. Due to its low surface tension, GS4 has been known to leak through mechanical fittings and certain thread sealants. A variant of the salt family, it can be extremely corrosive when exposed to air. CM does not recommend the use of GS4 with its products due to the leaking and ultimate corrosion problems associated with it.

Contact the ClimateMaster Technical Services Department if you have any questions as to antifreeze selection.

ANTIFREEZE CHARGING

It is highly recommended to utilize premixed antifreeze fluid where possible to alleviate many installation problems and extra labor.

The following procedure is based upon pure methanol and can be implemented during the Full Flush procedure with three way valves in the Figure 9D - Valve Position D. If a premixed methanol of 15°F freeze protection is used, the system can be filled and flushed with the premix directly to prevent handling pure methanol during the installation.

- 1) Flush loop until all air has been purged from system and pressurize to check for leaks before adding any antifreeze.
- 2) Run discharge line to a drain and hook up antifreeze drum to suction side of pump (if not adding below water level through approved container). Drain flush reservoir down to pump suction inlet so reservoir can accept the volume of antifreeze to be added.
- 3) Calculate the amount of antifreeze required by first calculating the total fluid volume of the loop from Table 3. Then using Table 4 for the appropriate

freeze protection level. Many southern applications require freeze protection because of exposed piping and flow controller ambient conditions. An extra 10°F of freeze protection is needed in Paradigm outdoor applications.

Table 3 - Fluid Volume of Common Piping Materials
Fluid Volume (gal/100' pipe)

Pipe	Size	Volume
Copper	1"	4.1
	1.25"	6.4
	1.5"	9.2
Rubber Hose	1"	3.9
Polyethylene	3/4" IPS SDR11	2.8
	1" IPS SDR11	4.5
	1 1/4" IPS SDR11	8.0
	1 1/2" IPS SDR11	10.9
	2" IPS SDR11	18.0
	1 1/4" IPS SCH40	8.3
	1 1/2" IPS SCH40	10.9
2" IPS SCH40	17.0	
Unit Heat Exchanger	Typical	1.0
Flush cart tank	10" diam x 3 ft	10.0

Table 4 - Antifreeze Percentages by Volume

Type	Minimum Temperature for Freeze Protection			
	10°F	15°F	20°F	25°F
Methanol	25%	21%	16%	10%
100% USP food grade Propylene Glycol	38%	30%	22%	15%

- 4) Isolate unit and prepare to flush only through loop. start flush cart, and gradually introduce the required amount of liquid to the flush cart tank (always introduce alcohols under water or use suction of pump to draw in directly to prevent furring) until attaining the proper antifreeze protection. Noting the rise in flush reservoir level indicates amount of antifreeze added some carts are marked with measurements in gallons. A ten inch diameter 3 foot cylinder holds approximately 8 gallons of fluid. If more than one tankful is required, the tank should be drained immediately by opening the waste valve of the flush cart noting the color of the discharge fluid. Adding food coloring to the antifreeze can help indicate where the antifreeze is in the circuit and prevents the dumping of antifreeze out the waste port. Repeat if necessary.
- 5) Be careful when handling methanol. The fumes are flammable, and care should be taken with all flammable liquids, such as alcohols. Open flush valves to flush through both the unit and the loop and flush until fluid is homogenous and mixed. **It is recommended to run the unit in the heating and cooling mode for 15-20 minutes each to 'temper' the fluid temperature and prepare it for pressurization. Devoting this time to clean up can be useful. This procedure helps prevent the periodic "flat" loop condition.**
- 6) Close the flush cart return valve; and immediately thereafter, close the flush cart supply valve, leaving a positive pressure in the loop of approximately 50psi. This is a good time to pressure check the system as well. Check the freeze protection of the fluid with the proper hydrometer to ensure that the correct amount of antifreeze has been added to the system. The hydrometer can be dropped into the flush reservoir and the reading compared to Figure 1A for Methanol and 1B for Propylene Glycol to indicate the level of freeze protection. Do not antifreeze more than a +5°F freeze point. Specific gravity hydrometers are available from ClimateMaster. Repeat after reopening and flushing for a minute to ensure good second sample of fluid. **Inadequate antifreeze protection can cause nuisance freeze/stop lockouts during cold weather.**

Note: Always dilute alcohols with water (at least 50% solution) before using when possible.

Chart 1A - Methanol Specific Gravity

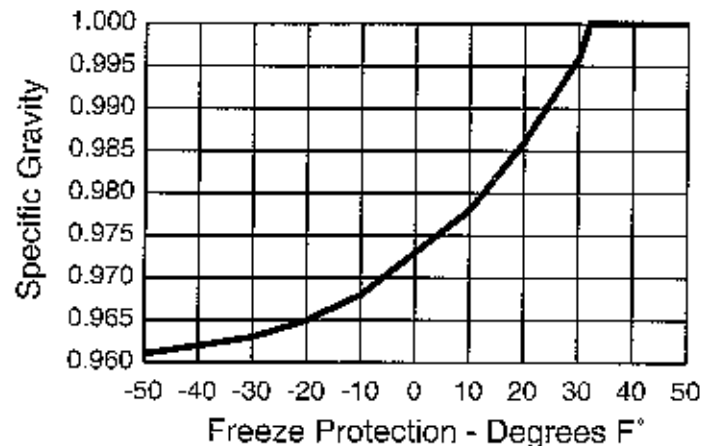
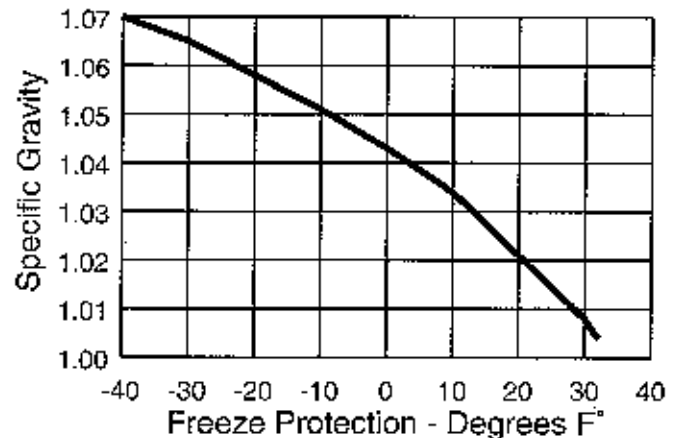

Chart 1B - Propylene Glycol Specific Gravity



- 7) Close the flush cart return valve; immediately thereafter, close the flush cart supply valve, shut off the flush cart leaving a positive pressure in the loop of approximately 40-50 psi for Summer and 50-75 psi for Winter. Refer to Figure 9E for more details.

Heat Pump Freeze/stop Setting

When an antifreeze is used the freeze/stop wires should be switched to activate the low temperature freeze/stop switch to avoid nuisance faults or lockouts. See the unit installation manual for further details on switching freeze/stop settings.

Pressure/Temperature Ports

The pressure/temperature ports (P/T ports) supplied with the earth loop connector kit are provided as a means of measuring flow and temperature. The water flow (GPM) through the unit can be checked by measuring the incoming water pressure at the supply water P/T port and subtracting the leaving water pressure at the return water P/T port. Comparing the pressure differential to the pressure drop/flow Table 5 will determine the flow rate through the unit. For reference, every 1 psi equals 2.31 feet of head if conversion is needed. ClimateMaster units require 2.25-3 gpm per nominal cooling ton when installed in conjunction with an earth loop. **Note:**

Minimum flow for units is 2.25 gpm per ton

Example: A VP036 with a 3.8 PSI pressure drop would be equivalent to 9 GPM on the chart. More flow will not hurt the performance. However, insufficient flow can significantly reduce capacity and possibly even cause damage to the heat pump in extreme conditions. Digital thermometers and pressure gauges needed for the P/T ports are available from ClimateMaster.

Note: Pressure/temperature gauges should be pushed gently into P/T ports to prevent internal damage to the port.

Earth Loop Pressure

The earth loop must have a slight positive pressure to operate the pumps (>3 psi). The system pressure will drop as the plastic earth loop pipe relaxes, and will fluctuate as the fluid temperature changes. Typical earth loop pressures range from approximately 15-50 psi. At the start-up of a system, you should leave the earth loops with a (static) holding pressure of approximately 40-50 psi summer or 50-75 psi winter. **Maximum operating pressure should never exceed 100 psi under any circumstance. It is recommended to run the unit in the heating and cooling mode for 15-20 minutes each to 'temper' the fluid temperature and prepare it for pressurization. This procedure helps prevent the periodic "flat" loop condition.**

Table 5 - Classic, Ultra Classic and Paradigm Pressure Drop

Unit	GPM	Pressure Drop (psi)			
		30°F	50°F	70°F	90°F
HP/VP 030	5	1.7	1.6	1.5	1.4
	8	2.8	2.6	2.4	2.3
	10	3.9	3.7	3.4	3.2
HP/VP 036	6	2.3	2.2	2.0	1.9
	9	3.8	3.6	3.3	3.1
	12	5.5	5.1	4.7	4.4
HP/VP 042	7	3.1	2.9	2.7	2.5
	10	5.3	5.0	4.6	4.3
	14	7.7	7.1	6.6	6.2
HP/VP 048	8	4.1	3.8	3.5	3.3
	12	7.3	6.8	6.3	5.9
	16	10.4	9.7	9.0	8.5
HP/VP 060	10	3.5	3.2	3.0	2.8
	15	7.7	7.1	6.6	6.2
	20	11.7	10.9	10.1	9.5
VT 036	4	1.2	1.1	1.0	0.9
	6	2.1	1.9	1.8	1.7
	8	3.4	3.1	2.9	2.7
VT 042	6	2.0	1.8	1.7	1.6
	8	3.1	2.9	2.7	2.5
	10	4.3	4.0	3.7	3.5
VT 048	6	1.5	1.4	1.3	1.2
	8	3.1	2.9	2.7	2.5
	10	4.3	4.0	3.7	3.5
VT 060	7	2.8	2.6	2.4	2.3
	10	4.3	4.0	3.7	3.5
	13	7.5	7.0	6.5	6.1
VT 072	7	2.8	2.6	2.4	2.3
	10	4.3	4.0	3.7	3.5
	13	7.5	7.0	6.5	6.1
PD18	3	2.6	2.4	2.2	2.1
	4	3.1	2.9	2.7	2.5
	5	3.7	3.5	3.2	3.0
PD24	3	1.2	1.2	1.1	1.0
	4.5	1.6	1.5	1.4	1.3
	6	2.0	1.9	1.8	1.7
PD30	4	1.8	1.7	1.5	1.4
	6	2.4	2.2	2.0	1.9
	8	3.2	2.9	2.7	2.6
PD36	5	2.0	1.9	1.7	1.6
	7	2.6	2.4	2.2	2.1
	9	3.3	3.0	2.8	2.7
PD42	5	2.0	1.9	1.7	1.6
	8	2.9	2.7	2.5	2.4
	11	4.2	3.9	3.6	3.4
PD48	6	2.3	2.1	2.0	1.8
	9	3.3	3.0	2.8	2.7
	12	4.7	4.4	4.0	3.8
PD60	8	1.5	1.4	1.3	1.2
	11	1.9	1.7	1.6	1.5
	14	2.4	2.2	2.1	1.9

FLOW CONTROLLER INITIAL START-UP

After pressurization, be sure to insure the loop flow controller provides adequate flow through the unit by checking pressure drop across the heat exchanger and comparing it to the figures shown in Table 5. Flow controller pump performance is shown in Chart 2.

Chart 2 - Flow Controller Performance

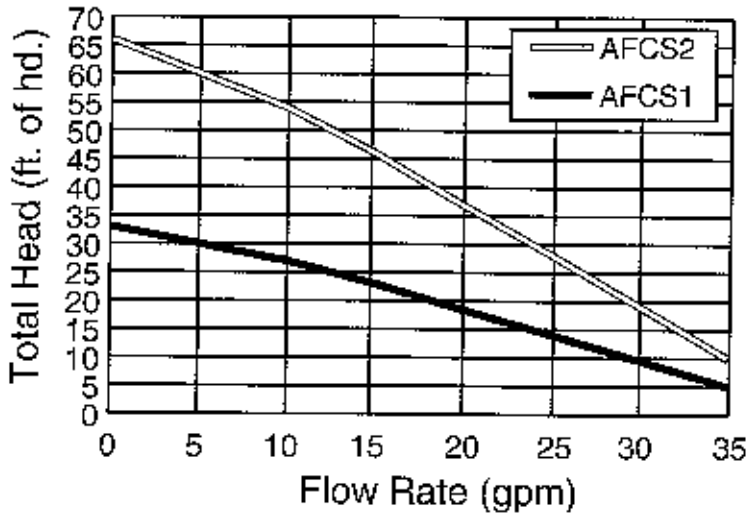

Start-Up of Flow Controller

- 1) Check to make sure that the loop and unit isolation valves are completely open and the flush ports are closed and sealed.
- 2) Check and record the earth loop pressure via the P/T ports. Loop Pressure = In _____ Out _____
- 3) Check and record the flow rate. Flow Rate = _____ gpm
- 4) Check performance of unit. Refer to unit installation manual. Replace all caps to prevent pressure loss.

PUMP CARTRIDGE REPLACEMENT PROCEDURE

First isolate the pump in question as in Figure 10. **Always disable power to the pumps** and remove pump power wiring if needed. Close valves as in Step 1 of Figure 10.

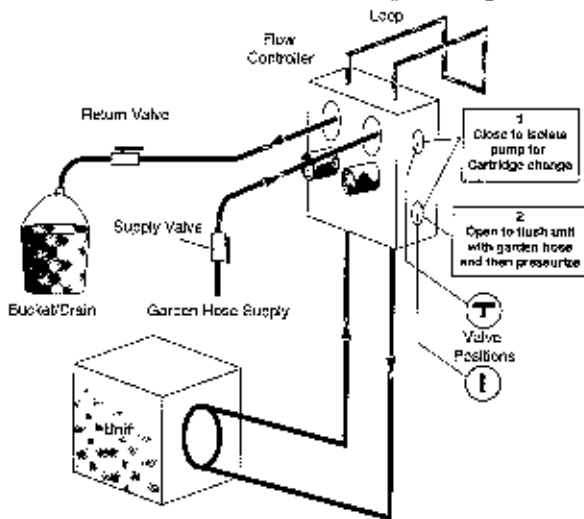

Figure 10 - Cartridge Replacement Procedure

- Remove two allen head mounting bolts and lift off pump stator housing. Lay out rags to soak of loop fluid.
- Remove remaining two allen head mounting bolts and remove cartridge noting the large 'o'-ring seal. Loop fluid could spill from system.
- Replace with new cartridge insuring the 'o'-ring is in place and install the two allen head mounting bolts.
- Reinstall the stator housing using the remaining allen head mounting bolts.
- Place garden hose supply and return on flush ports as shown in Figure 10 and open valves to flush through the unit portion of loop. When water flows clear, close return side to pressurize and finally close the supply side valve. Finally close 3-way valves to operation position Figure 9E. The loop can also be refilled using the complete procedure outlined for installation.

Remember This procedure will dilute the antifreeze mixture by a few gallons. If performed more than twice on any earth loop the antifreeze concentration should be checked with a hydrometer and antifreeze added as needed.

GEOHERMAL CLOSED LOOP DESIGN

Closed Loop Basics

Closed Loop Earth Coupled Heat Pump systems are commonly installed in one of three configurations: horizontal, vertical and pond loop. Each configuration provides the benefit of using the moderate temperatures of the earth as a heat source/heat sink. Piping configurations can be either series or parallel.

Series piping configurations typically use 1-1/4 inch, 1-1/2 inch or 2 inch pipe. Parallel piping configurations typically use 3/4 inch or 1 inch pipe for loops and 1-1/4 inch, 1-1/2 inch or 2 inch pipe for headers and service lines. Parallel configurations require headers to be either "closed-coupled" short headers or reverse return design.

Select the installation configuration which provides the most cost effective method of installation after considering all application constraints.

Loop design takes into account two basic factors. The first is accurately engineered system to function properly with low pumping requirement and adequate heat transfer to handle the load of the structure. The second is to design a loop with the lowest installed cost while still maintaining a high level of quality. These factors have been taken into account in all of the loop designs presented in this manual.

In general terms all loop lengths have been sized by the Climate Master loop sizing software so that every loop has approximately the same operating costs. In other words, at the end of the year the homeowner would have paid approximately the same amount of money for heating, cooling, and hot water no matter which loop type was installed. This leaves the installed cost of the loop as the main factor for determining the system payback. Therefore this analysis says 'install the most economical system possible given the installation requirements'.

Pipe Fusion Methods

Two basic types of pipe joining methods are available for earth coupled applications. Polyethylene pipe can be socket fused or butt fused. In both processes the pipe is actually melted together to form a joint that is even stronger than the original pipe. Although when either procedure is performed properly the joint will be stronger than the pipe wall. ClimateMaster prefers socket fusion in the fusion of 2" pipe or less because of the following:

- Allowable tolerance of mating the pipe is much greater in socket fusion. According to general fusion guidelines, a 3/4" SDR11 butt fusion joint alignment can be off no more than 10% of the wall thickness (0.01 in.). A hundredth of an inch accuracy while fusing in a difficult position can be almost impossible to attain in the field.
- The actual socket fusion joint is 3 to 4 times the cross sectional area of its butt fusion counterpart in

sizes under 2" and therefore tends to be more forgiving of operator skill.

- Joints are frequently required in difficult trench connections and the smaller socket fusion iron is more mobile and operators will have less of a tendency to cut corners during the fusion procedure such as can happen during the facing and alignment procedure of butt fusion.

In general socket fusion loses these advantages in fusion joints larger than 2" and of course socket fittings become very expensive and time consuming in these larger sizes as well. Therefore butt fusion is general used in sizes larger than 2". In either joining method proper technique is essential for long lasting joints. All ClimateMaster supplied pipe and fittings are IGSHPA approved. All fusion joints should be performed by certified fusion technicians. Table 6 illustrates the proper fusion times for ClimateMaster Geothermal PE Pipe.

Table 6 - Fusion Times for ClimateMaster Polyethylene Pipe

Pipe Size	Socket Fusion Time (sec.)-	Butt Fusion	
		Time (sec.)	Bead (in.)
3/4" IPS	8-10	8	1/16
1" IPS	10-14	12	1/16
1-1/4" IPS	12-15	15	1/16-1/8
1-1/2" IPS	15-18	15	1/16-1/8
2" IPS	18-22	18	1/8

Holding time of 60 sec. Cure time of 20 min.
Always use a timing device.

Parallel vs Series Configurations

Initially, loops were all designed using series style flow due to the lack of fusion fittings needed in parallel systems. This resulted in large diameter pipe (>1 1/4") being used to reduce pumping requirements due to the increased pressure drop of the pipe. Since the fusion fittings have become available parallel flow using (3/4" IPS) for loops 2 ton and above has become the standard for a number of reasons.

- **Cost of Pipe** - the larger diameter (>1 1/4") pipe is twice the cost of the smaller (3/4" IPS) pipe however the heat transfer capability due to the reduced surface area of the smaller pipe is only decreased by approximately 10-20%. In loop designs using the smaller pipe the pipe length is simply lengthened to compensate for the small heat transfer reduction. however, it still results in around 50% savings in pipe costs over the larger pipe in series. In some areas 1 1/4" vertical bores can be more cost effective, where drifting costs are high.
- **Pumping power** - parallel systems generally can have much lower pressure drop and thus smaller pumps due to the multiple flow paths of smaller pipes in parallel.

- **Installation ease** - The smaller pipe is easier to handle during installation than the larger diameters. The 'memory' of the pipe can be especially cumbersome when installing in cold conditions. Smaller pipe takes less time to fuse and is easier to cut etc.

When Should Series Loops Be Used?

In smaller loops of two tons or less, the reasons for parallel listed above may be less obvious. In these cases, series loops can have some additional advantages:

- **No header** - fittings tend to be more expensive and require extra labor and skill to install.
- **Simple design** - no confusing piping arrangement for easier installation by less experienced installers

Loop Configuration - Determining the style of loop primarily depends on lot size, and 'dirt' costs. For instance, horizontal 1 pipe will have significantly (400%) more trench than a horizontal 6 pipe. However the 6 pipe will have about 75% more feet of pipe, therefore if trenching costs are higher than the extra pipe costs the 6 pipe is the best choice. Remember that labor is also a factor in loop costs. The 6 pipe could also be chosen because a small lot as well. Generally a contractor will know after a few installations which configuration is the most cost effective for him. Then this information can be applied to later installations for a more overall cost effective installation for his particular area. Depth of the loop in horizontal systems generally does not exceed 5

feet because of trench safety issues and the sheer amount of dirt required to move. In vertical systems economic depth due to escalating drilling costs in rock can sometimes require what is referred to as a parallel-series loop. That is, a circuit will loop down and up through two consecutive bores (series) to total the required circuit length required.

Loop Circuiting - Loops should be designed with a compromise between pressure drop and good turbulence in the heat exchange pipe for heat transfer. Therefore the following rules should be observed when designing a loop:

- 3 gpm per ton flow rate (2.25 gpm per ton minimum). In larger systems 2.5 to 2.7 gpm per ton is adequate in most cases. Overseeing the pumps to attain exactly 3 gpm per ton is generally not cost effective from an operating cost standpoint.
- One circuit per nominal equipment ton with 3/4" IPS and 1/2 circuit per ton with 1 1/4" IPS pipe. This rule can be deviated by one circuit or so for different loop configurations.

Header Design - Headers for parallel loops should be designed with two factors in mind, the first is pressure drop and the second is flushability. The header shown in Figure 11A is a standard header design through 15 tons for polyethylene pipe with 2" supply and return runouts. The header shown in Figure 11B is a standard header

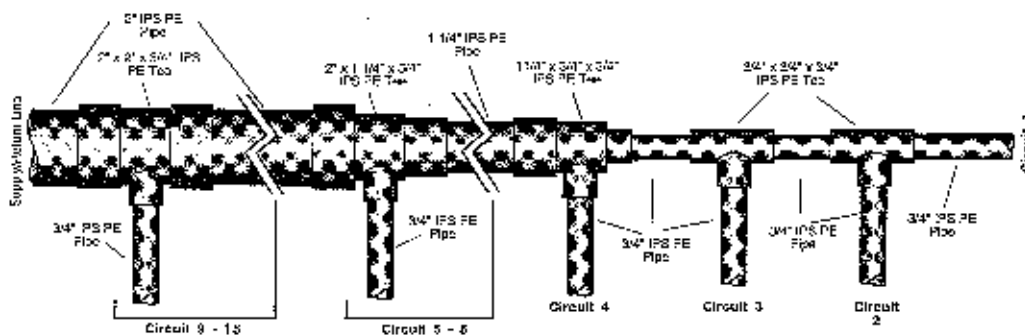

Figure 11A - Typical Header through 15 tons

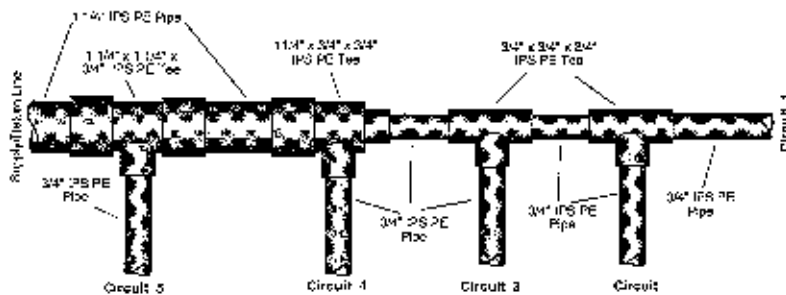

Figure 11B - Typical Header through 5 tons

design through 5 tons for polyethylene pipe using 1-1/4" supply and return runouts. Notice the reduction of pipe from 2" IPS supply/return through circuits 12 to 8 and then the line is reduced to 1 1/4" IPS pipe for circuits 7 to 4 and then finally the header line is reduced to 3/4" IPS to supply circuits 3, 2, and 1. This allows minimum pressure drop while still maintaining 2 fps velocity throughout the header under normal flow conditions (3 gpm/ton), thus the header as shown is self-flushing under normal flow conditions. This leaves the circuits themselves (3/4" IPS) as the only section of the loop not attaining 2 fps flush velocity under normal flow conditions (3 gpm/ton & normally 3 gpm/circuit). 3/4" IPS requires 3.8 gpm to attain 2 fps velocity therefore to calculate flushing requirements for any PE loop using the header styles shown simply multiply the number of circuits by the flushing flow rate of each circuit (3.8 gpm for 2 fps velocity). For instance on a 5 circuit loop the flush flow rate is 5 circuits x 3.8 gpm/circuit = 19 gpm.

Headers that utilize large diameter pipe feeding the last circuits should not be used. In PE 1 1/4" IPS pipe requires 9.5 gpm to attain 2 fps and since increasing the flow through the last circuit would also require increasing the flow through the other circuits at an equal rate as well, we can estimate the flush flow requirements by multiplying the number of circuits by 9.5 gpm (in 1 1/4" IPS) or for instance a 5 circuit loop in PE would require 5 circuits x 9.5 gpm/circuits = 47.5 gpm to attain flush flow rate. This is clearly is an impossible flow to achieve with a pump of any size.

Header Layout - Generally header layouts are more cost effective with short headers. This requires centrally locating the header to all circuits and then bringing the

circuits to the header. One of the easiest implementations is to angle all trenches into a common pit similar to a starburst. This layout can utilize the laydown or 'L' header and achieves reverse return flow by simply laying the headers down in a mirror image and thus no extra piping or labor. Figure 12 details a "laydown header."

Inside Piping - Polyethylene pipe provides an excellent no leak piping material inside the building. Inside piping fittings and elbows should be limited to prevent excessive pressure drop. Hose kits employing 1" rubber hose should be limited in length to 10-15 feet per run to reduce pressure drop problems. In general 2 feet of head pressure drop is allowed for all earth loop fittings which would include 10-12 elbows for inside piping to the flow controller. This allows a generous amount of maneuvering to the flow controller with the inside piping. 3/8 to 1/2" Closed cell insulation should be used on all inside piping where loop temperatures below 50°F are anticipated. All barbed connections should be double clamped.

Flow Controller Selection - The pressure drop of the entire ground loop should be estimated for the selection of the flow controller. In general if basic loop design rules are followed units of 3 tons or less will require only 1 circulating pump (AFCS1). Units from 3.5 to 6 tons will require a two pump system (AFCS2). As a caution, loop pressure drop calculation should be performed for accurate flow estimation in any system including unit, hose kit, inside piping, supply/return headers, circuit piping, and fittings. Use Table 7A, B and C for pressure drop calculations using methanol and various piping materials. Tables showing other antifreezes are available from ClimateMaster Technical Support.

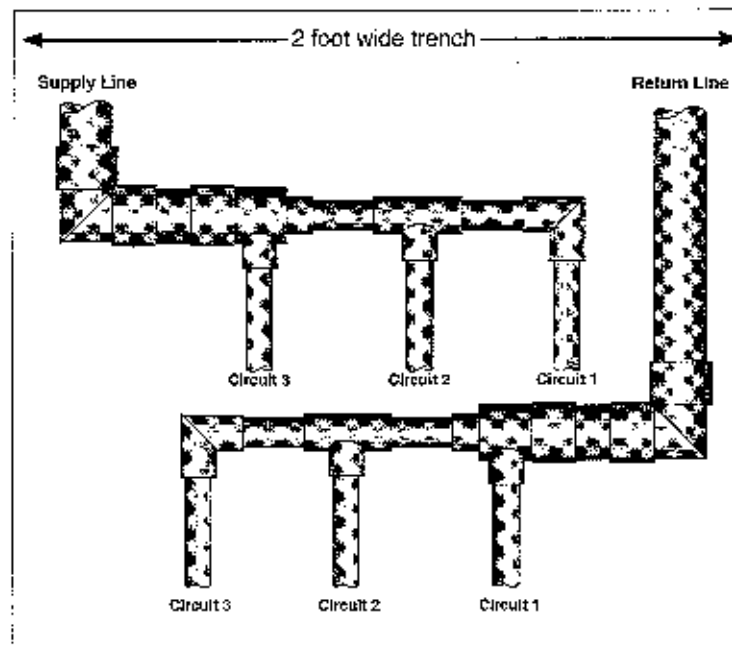

Figure 12 - Typical 'Laydown' Header

Table 7A - Polyethylene Pressure Drop Table (using 20% methanol @ 30°F per 100 ft. of pipe)

FLOW RATE	3/4" IPS SDR 11			1" IPS SDR 11			1 1/4" IPS SCH 40			1 1/2" IPS SCH 40			2" IPS SCH 40		
	PD (ft)	Vel ft/s	Re	PD (ft)	Vel ft/s	Re	PD (ft)	Vel ft/s	Re	PD (ft)	Vel ft/s	Re	PD (ft)	Vel ft/s	Re
1	0.36	0.55	1162	0.12	0.35	930	0.04	0.21	724	0.02	0.16	621	0.01	0.10	484
2	1.21	1.11	2325	0.42	0.71	1860	0.13	0.43	1449	0.06	0.32	1242	0.02	0.19	967
3	2.47	1.68	3487	0.85	1.06	2789	0.26	0.64	2173	0.18	0.47	1863	0.04	0.29	1451
4	4.08	2.21	4850	1.41	1.41	3719	0.43	0.86	2898	0.21	0.63	2484	0.06	0.38	1936
5	6.04	2.76	5812	2.09	1.77	4649	0.64	1.07	3622	0.31	0.79	3105	0.09	0.48	2418
6	8.30	3.32	6975	2.87	2.12	5579	0.88	1.29	4347	0.42	0.95	3726	0.13	0.57	2902
7	10.87	3.87	8137	3.78	2.48	6503	1.15	1.50	5071	0.55	1.10	4347	0.17	0.67	3386
8	13.74	4.42	9300	4.78	2.83	7439	1.45	1.72	5796	0.70	1.28	4968	0.21	0.77	3869
9	16.88	4.98	10462	5.84	3.18	8368	1.79	1.93	6520	0.86	1.42	5589	0.26	0.86	4353
10	20.30	5.53	11625	7.03	3.54	9298	2.15	2.15	7245	1.03	1.56	6209	0.32	0.96	4837
11	23.99	6.08	12787	8.30	3.89	10228	2.54	2.36	7969	1.22	1.73	6890	0.37	1.05	5320
12	27.99	6.53	13950	9.67	4.24	11158	2.95	2.58	8693	1.42	1.89	7451	0.43	1.15	5804
13	32.13	7.19	15112	11.12	4.60	12088	3.40	2.79	9418	1.63	2.05	8072	0.50	1.24	6288
14				12.68	4.95	13018	3.87	3.01	10142	1.86	2.21	8693	0.57	1.34	6771
15				14.29	5.30	13947	4.37	3.22	10867	2.10	2.37	9314	0.64	1.44	7255
16				16.00	5.66	14877	4.89	3.43	11591	2.35	2.52	9935	0.72	1.53	7739
17				17.79	6.01	15807	5.44	3.65	12316	2.61	2.68	10556	0.80	1.63	8222
18				19.66	6.37	16737	6.01	3.86	13040	2.89	2.84	11177	0.88	1.72	8706
19				21.61	6.72	17667	6.60	4.08	13765	3.17	3.00	11798	0.97	1.82	9190
20				23.64	7.07	18597	7.22	4.29	14489	3.47	3.15	12419	1.06	1.91	9673
21				25.75	7.43	19526	7.87	4.51	15214	3.78	3.31	13040	1.15	2.01	10157
22				27.93	7.78	20456	8.53	4.72	15938	4.10	3.47	13661	1.25	2.11	10641
23				30.19	8.13	21386	9.29	4.94	16663	4.44	3.63	14282	1.35	2.20	11124
24							10.04	5.15	17387	4.78	3.79	14903	1.46	2.30	11608
25							10.67	5.37	18111	5.13	3.94	15524	1.57	2.39	12092
26							11.43	5.58	18836	5.50	4.10	16145	1.68	2.49	12576
28							13.02	6.01	20285	6.26	4.42	17387	1.81	2.68	13543
30							14.69	6.44	21734	7.06	4.73	18628	2.18	2.87	14510
32							16.44	6.87	23183	7.91	5.05	19870	2.41	3.06	15478
34							18.28	7.30	24632	8.79	5.36	21112	2.63	3.25	16445
36							20.21	7.73	26080	9.71	5.68	22354	2.97	3.44	17412
38							22.21	8.16	27529	10.69	5.99	23596	3.26	3.64	18380
40							24.30	8.59	28978	11.68	6.31	24838	3.57	3.83	19347
42							26.46	9.02	30427	12.72	6.62	26080	3.88	4.02	20314
44							28.71	9.45	31876	13.80	6.94	27322	4.21	4.21	21282
46							31.03	9.88	33325	14.92	7.26	28564	4.55	4.40	22249
48										16.07	7.57	29806	4.91	4.59	23216
50										17.26	7.89	31047	5.27	4.78	24184

Table 7B - Canadian Polyethylene (CSA) Pressure Drop Table (using 20% methanol @ 30°F per 100 ft. of pipe)

FLOW RATE	3/4" IPS CSA 160			1" IPS CSA 160			1 1/4" IPS CSA 100			1 1/2" IPS CSA 100			2" IPS CSA 100		
	PD (ft)	Vel ft/s	Re	PD (ft)	Vel ft/s	Re	PD (ft)	Vel ft/s	Re	PD (ft)	Vel ft/s	Re	PD (ft)	Vel ft/s	Re
1	0.49	0.83	1242	0.17	0.41	996	0.04	0.21	713	0.02	0.16	629	0.01	0.10	498
2	1.66	1.26	2484	0.58	0.81	1992	0.12	0.42	1425	0.06	0.32	1245	0.02	0.20	995
3	3.38	1.89	3726	1.18	1.22	2987	0.24	0.62	2138	0.13	0.48	1868	0.04	0.30	1493
4	5.50	2.52	4968	1.96	1.62	3983	0.40	0.83	2850	0.21	0.63	2490	0.07	0.41	1991
5	8.28	3.15	6210	2.99	2.03	4979	0.59	1.04	3583	0.31	0.79	3113	0.11	0.51	2488
6	11.37	3.79	7452	3.98	2.43	5975	0.81	1.25	4275	0.43	0.95	3735	0.15	0.61	2986
7	14.89	4.42	8694	5.21	2.84	6970	1.06	1.45	4988	0.56	1.11	4358	0.19	0.71	3483
8	18.80	5.05	9935	6.58	3.24	7966	1.34	1.66	5701	0.71	1.27	4990	0.24	0.81	3981
9	23.11	5.68	11177	8.09	3.65	8962	1.65	1.87	6419	0.87	1.43	5603	0.30	0.91	4479
10	27.79	6.31	12419	9.73	4.06	9958	1.98	2.08	7126	1.04	1.59	6225	0.36	1.01	4976
11	32.83	6.94	13661	11.50	4.46	10953	2.35	2.29	7838	1.23	1.74	6848	0.43	1.11	5474
12	38.23	7.57	14903	13.39	4.87	11949	2.73	2.49	8551	1.44	1.90	7470	0.50	1.22	5972
13	43.98	8.20	16145	15.40	5.27	12945	3.14	2.70	9264	1.66	2.06	8093	0.57	1.32	6469
14				17.53	5.68	13941	3.58	2.91	9976	1.88	2.22	8715	0.65	1.42	6967
15				19.78	6.08	14936	4.04	3.12	10689	2.12	2.38	9338	0.73	1.52	7465
16				22.15	6.49	15932	4.52	3.32	11407	2.38	2.54	9960	0.82	1.62	7962
17				24.63	6.90	16928	5.03	3.53	12114	2.64	2.69	10583	0.91	1.72	8460
18				27.22	7.30	17924	5.55	3.74	12826	2.92	2.85	11205	1.01	1.82	8957
19				29.92	7.71	18920	6.10	3.95	13539	3.21	3.01	11828	1.11	1.92	9455
20				32.73	8.11	19915	6.68	4.15	14252	3.51	3.17	12450	1.21	2.03	9953
21				35.65	8.52	20911	7.27	4.36	14964	3.83	3.33	13073	1.32	2.13	10450
22				38.67	8.92	21907	7.89	4.57	15677	4.15	3.49	13695	1.43	2.23	10948
23				41.80	9.33	22903	8.53	4.78	16389	4.49	3.65	14318	1.55	2.33	11446
24				45.03	9.73	23898	9.19	4.98	17102	4.84	3.80	14940	1.67	2.43	11943
25							9.87	5.19	17814	5.19	3.96	15563	1.79	2.53	12441
26							10.57	5.40	18527	5.56	4.12	16185	1.92	2.63	12939
28							12.03	5.82	19952	6.33	4.44	17430	2.19	2.84	13934
30							13.58	6.23	21377	7.15	4.76	18675	2.47	3.04	14929
32							15.20	6.65	22803	8.00	5.07	19920	2.76	3.24	15924
34							16.90	7.06	24228	8.90	5.39	21165	3.07	3.44	16920
36							18.68	7.48	25653	9.83	5.71	22410	3.39	3.65	17915
38							20.53	7.89	27078	10.81	6.02	23655	3.73	3.85	18910
40							22.46	8.31	28503	11.82	6.34	24900	4.08	4.05	19905
42							24.46	8.72	29928	12.88	6.66	26146	4.45	4.25	20901
44							26.54	9.14	31354	13.97	6.97	27391	4.82	4.46	21896
46							28.69	9.55	32779	15.10	7.29	28636	5.21	4.66	22891
48										16.27	7.61	29881	5.62	4.86	23887
50										17.47	7.93	31126	6.03	5.06	24882

Table 7C - Rubber Hose Pressure Drop Table (using 20% methanol @ 30°F per 100 ft. of pipe)

FLOW RATE	1" IPS RUBBER HOSE			1 1/2" IPS RUBBER HOSE			2" IPS RUBBER HOSE		
	PD (ft)	Vel ft/s	Re	PD (ft)	Vel ft/s	Re	PD (ft)	Vel ft/s	Re
1	0.18	0.41	1000	0.03	0.21	667	0.01	0.10	482
2	0.59	0.82	2000	0.09	0.43	1333	0.02	0.19	967
3	1.21	1.23	2999	0.18	0.64	2000	0.04	0.29	1451
4	2.00	1.64	3999	0.29	0.86	2666	0.06	0.38	1935
5	2.85	2.04	4998	0.43	1.07	3333	0.09	0.48	2418
6	4.36	2.45	5998	0.59	1.29	3999	0.13	0.57	2902
7	5.91	2.86	6998	0.77	1.50	4666	0.17	0.67	3386
8	6.71	3.27	7998	0.96	1.72	5332	0.21	0.77	3869
9	8.25	3.68	8998	1.20	1.93	5999	0.26	0.86	4353
10	9.92	4.09	9995	1.45	2.15	6665	0.32	0.96	4837
11	11.72	4.50	10997	1.71	2.36	7332	0.37	1.05	5320
12	13.64	4.91	11997	1.99	2.58	7999	0.43	1.15	5804
13	15.70	5.31	12997	2.29	2.79	8665	0.50	1.24	6288
14	17.87	5.72	13997	2.60	3.01	9331	0.57	1.34	6771
15	20.16	6.13	14996	2.94	3.22	9998	0.64	1.44	7255
16	22.57	6.54	15998	3.29	3.43	10664	0.72	1.53	7739
17	25.10	6.95	16996	3.66	3.65	11331	0.80	1.63	8222
18	27.74	7.36	17996	4.04	3.86	11997	0.88	1.72	8706
19	30.49	7.77	18995	4.44	4.08	12664	0.97	1.82	9190
20	33.36	8.18	19995	4.86	4.29	13330	1.05	1.91	9673
21				5.29	4.51	13997	1.13	2.01	10157
22				5.74	4.72	14663	1.25	2.11	10641
23				6.21	4.94	15330	1.33	2.20	11124
24				6.69	5.15	15995	1.46	2.30	11608
25				7.18	5.37	16663	1.57	2.39	12092
26				7.69	5.59	17329	1.68	2.49	12576
28				8.76	6.01	18652	1.91	2.68	13543
30				9.88	6.44	19995	2.16	2.87	14510
32				11.07	6.87	21328	2.41	3.06	15476
34				12.30	7.30	22661	2.68	3.25	16445
36				13.60	7.73	23994	2.97	3.44	17412
38				14.95	8.16	25327	3.26	3.64	18380
40				16.35	8.59	26660	3.57	3.83	19347
42				17.81	9.02	27993	3.88	4.02	20314
44				19.32	9.45	29326	4.21	4.21	21282
46				20.88	9.88	30659	4.55	4.40	22249
48				22.50	10.30	31992	4.91	4.59	23216
50				24.16	10.73	33325	5.27	4.78	24184

CLOSED LOOP INSTALLATION

Prior to installation, locate and mark all existing underground utilities, piping, etc. Install loops for new construction before sidewalks, patios, driveways and other construction has begun. During construction, accurately mark all ground loop piping on the plot plan as an aid in avoiding potential future damage to the installation.

Loop Piping Installation

The typical closed loop ground source system is shown in Figure 13. All earth loop piping materials should be limited to only polyethylene fusion in inground sections of the loop and galvanized or steel fittings should not be used at any time due to their tendency to corrode by galvanic action. All plastic to metal threaded fittings should be avoided as well due to their potential to leak in earth coupled applications and a flanged fitting substituted. P/T plugs should be used so that flow can be measured using the pressure drop of the unit heat

exchanger in lieu of other flow measurement means. Earth loop temperatures can range between 25-110°F and 2.25 to 3 gpm of flow per ton of cooling capacity is recommended in any earth loop applications.

Horizontal Applications

To install Horizontal earth couplings, dig trenches using either a chain-type trenching machine or a backhoe. Dig trenches approximately 8-10 feet apart. Trenches must be at least 5 feet from existing utility lines, foundations and property lines and at least 10 feet from privies and wells. Trenches may be curved to avoid obstructions and may be turned around corners.

When multiple pipes are laid in a trench, space pipes properly and backfill carefully to avoid disturbing the spacing of the pipes in the trench. Figure 14 details common loop cross-sections used in horizontal loops.

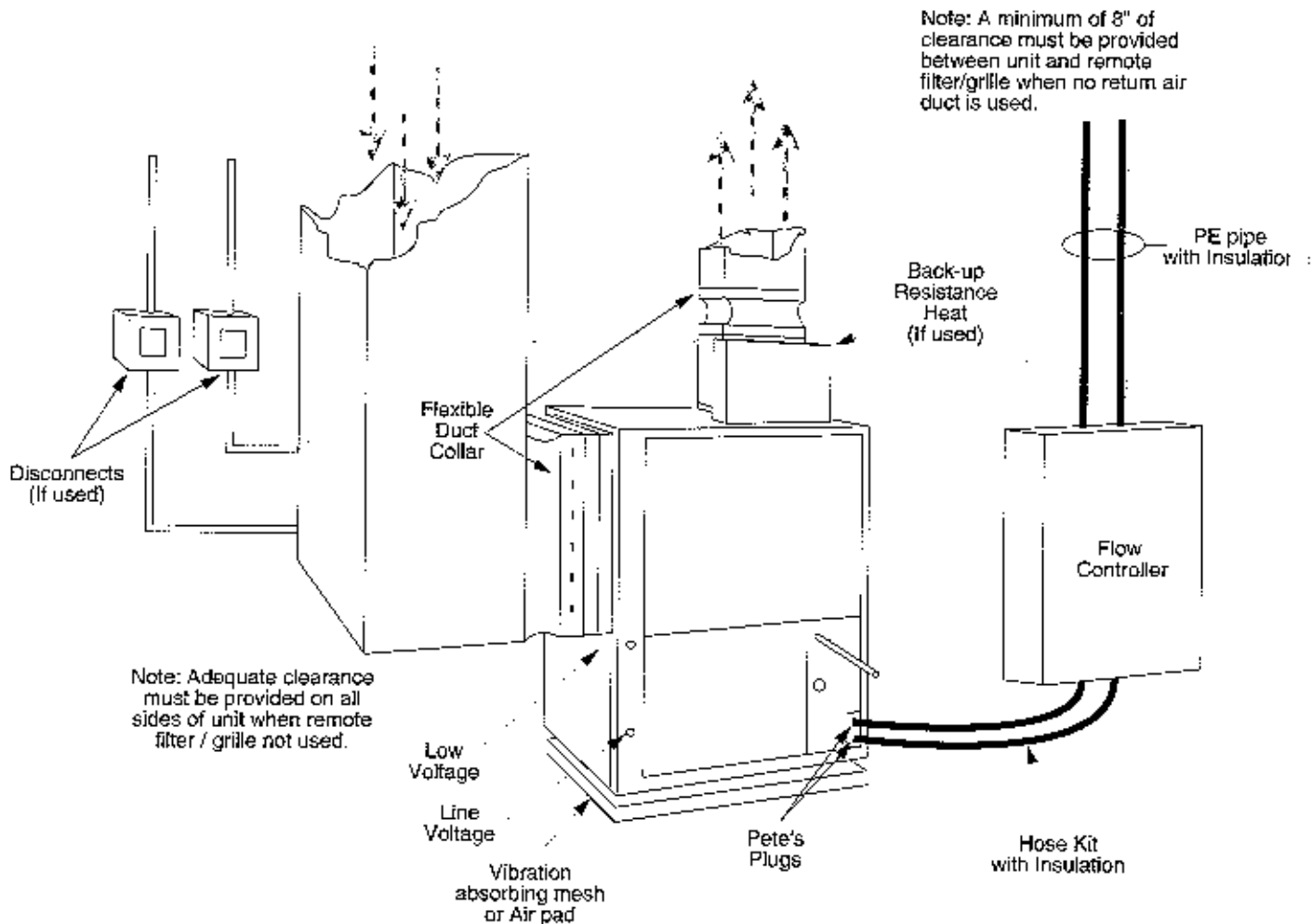

Figure 13 - Typical Closed Loop Application

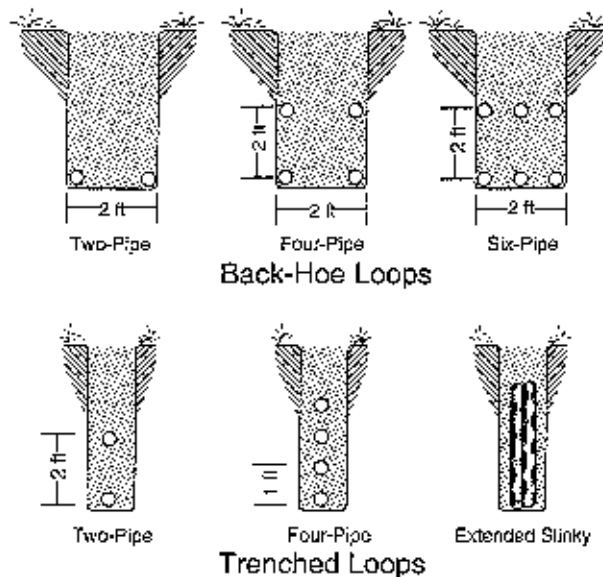

Figure 14 - Typical Horizontal Loop Configurations

Vertical Applications

To install Vertical earth couplings, drill boreholes using any size drilling equipment. Regulations which govern water well installations also apply to vertical ground loop installations. Vertical applications typically require multiple boreholes. Space boreholes a minimum of 10 feet apart. In southern or cooling dominated climates 15 feet is required.

The minimum diameter for 3/4 inch or 1 inch U-bend well bores is 4 inches. Larger diameter boreholes may be drilled if convenient, unless local code requires an expensive method of backfilling. Assemble each U-bend assembly, fill with water and pressure test prior to insertion into the borehole.

To add weight and prevent the pipe from curving and digging into the borehole wall during insertion, tape a length of conduit, pipe or reinforcing bar to the U-bend end of the assembly. This technique is particularly useful when inserting the assembly into a borehole filled with water or drilling mud solutions, since a water filled pipe is buoyant under these circumstances. Tape the pipes together approximately every 10 feet to prevent the assembly from separating under downward pressure and bowing out against the borehole wall.

Carefully backfill the boreholes to within 10 feet of the surface. Follow IGSPHA specifications for backfilling unless local codes mandate otherwise.

When all U-bends are installed, dig the header trench 4 to 6 feet deep and as close to the boreholes as possible. Use a spade to break through from ground level to the bottom of the trench. At the top of the hole, dig a relief to allow the pipe to bend for proper access to the header. The "laydown" header mentioned earlier is a cost effective method for connecting the bores. Figure 15 illustrates common vertical bore heat exchangers.

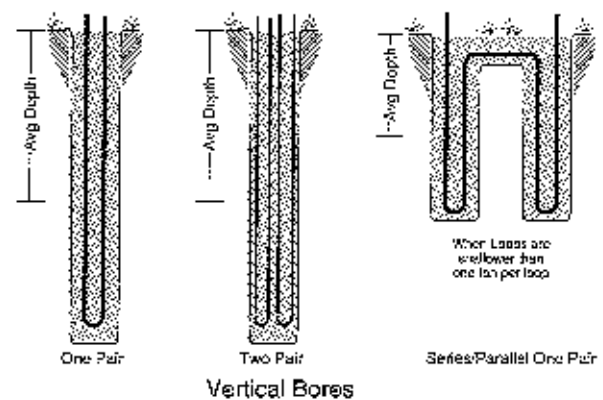

Figure 15 - Typical Vertical Loop Configurations

Pond/Lake Applications

Pond loops are one of the most cost effective applications of geothermal systems. Typically 1 coil of 300 ft of PE pipe per ton is sunk in a pond and headered back to the structure. Minimum pond sizing is 1/2 acre and 8 feet deep for an average residential home. Actual area can be 1500-3000 ft² per ton of cooling. In the north, an ice cover is required during the heating season to allow the pond to reach an average 39°F. Winter aeration or excessive wave action can lower the pond temperature preventing proper operation of the geothermal system. Direct use of pond or lake water is discouraged because of the potential problems of heat exchanger fouling and pump suction lift. Heat exchanger may be constructed of either multiple 300' coils of pipe or slinky style Figure 16. In northern applications the slinky or matt style is recommended due to its superior performance in heating. Due to pipe and antifreeze buoyancy pond heat exchanger will most likely need weighted down to prevent floating. 300 foot coils require two 4" x 8" x 16" blocks (19 lbs. each) or 8-10 bricks (4.5 lbs each) and every 20 ft of 1-1/4" pipe requires 1 three hole brick. Coils are supported off of the bottom by the concrete blocks or bricks. The supply/return trenching should begin at the structure and work toward the pond. Near the pond the trench should be halted and back filled most of the way. A new trench should be started from the pond back toward the partially backfilled first trench to prevent pond from flooding back to the structure.

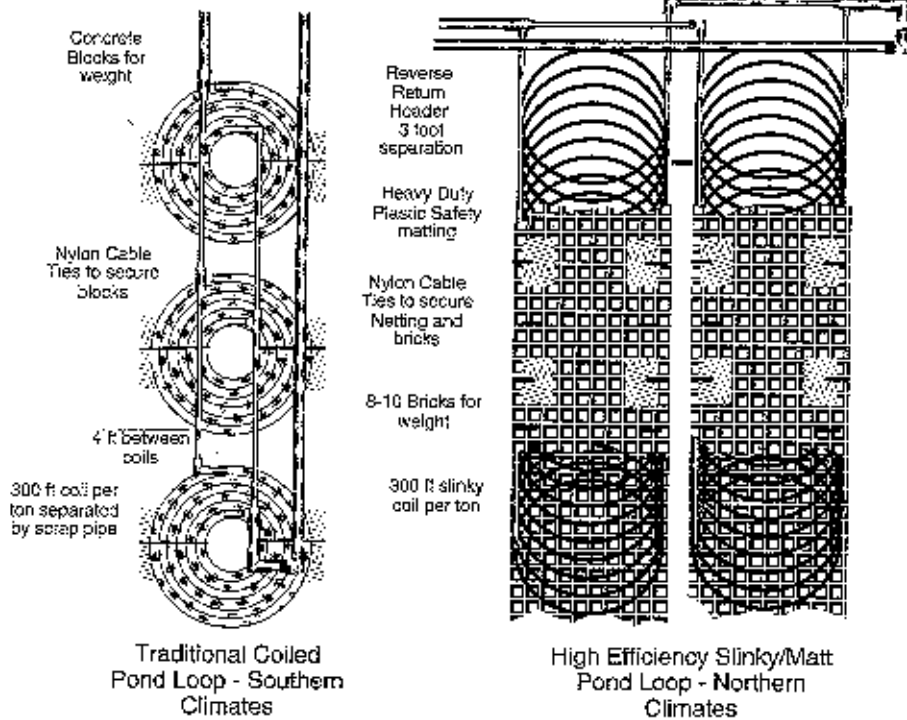

Figure 16 - Typical Pond Heat Exchanger Configurations

BUILDING ENTRY

Seal and protect the entry point of all earth coupling entry points into the building using hydraulic cement.

Slab on Grade Construction

New Construction: When possible, position the pipe in the proper location prior to pouring the slab. To prevent wear as the pipe expands and contracts, protect the pipe with a layer of insulation as shown in Figure 17. When the slab is poured prior to installation, create a chase through the slab for the service lines with 4 inch PVC street elbows and sleeves.

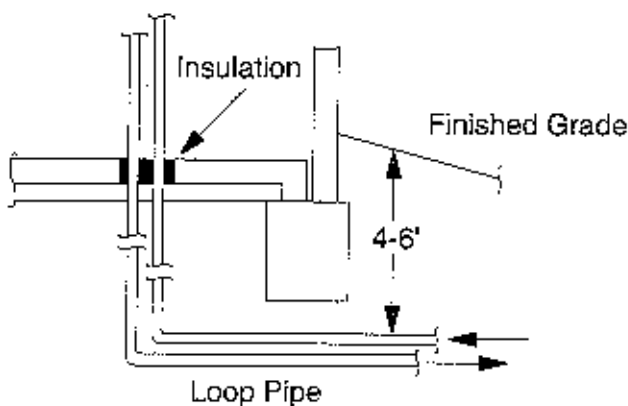

Figure 17 - Slab on Grade Entry Detail

Retrofit Construction

Trench as close as possible to the footing. Bring the loop pipe up along the outside wall of the footing until it is higher than the slab. Enter the building as close to the slab as the construction allows. Shield and insulate the pipe to protect it from damage and the elements as shown in Figure 18.

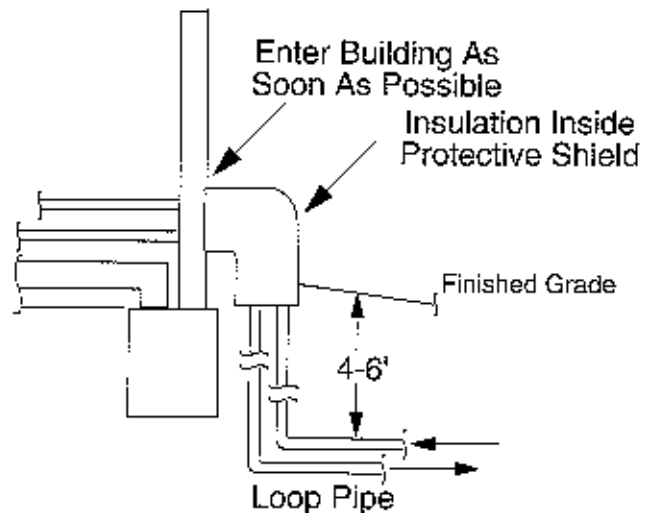

Figure 18 - Retrofit Construction Detail

Pier and Beam (crawl space)

New and Retrofit Construction: Bury the pipe beneath the footing and between piers to the point that it is directly below the point of entry into the building. Bring the pipe up into the building. Shield and insulate piping as shown in Figure 19 to protect it from damage.

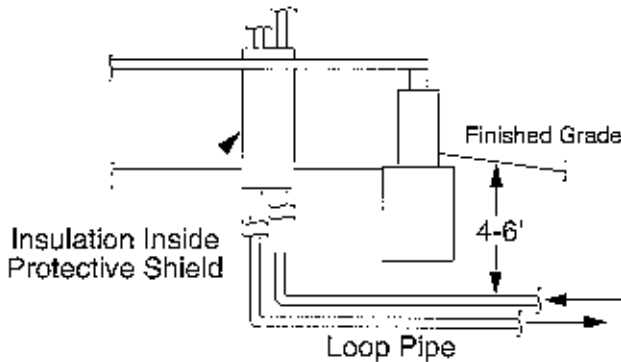

Figure 19 - Pier and Beam Entry Detail

Below Grade Entry

New and Retrofit Construction: Bring the pipe through the wall as shown in Figure 20. For applications in which loop temperature may fall below freezing, insulate pipes at least 4 feet into the trench to prevent ice forming near the wall.

Upon completion of the ground loop piping, pressure test the loop to assure a leak free system.

Horizontal Systems: Test individual loops as installed. Test entire system when all loops are assembled.

Vertical U-Bends and Pool Loop Systems: Test Vertical U-bends and pond loop assemblies prior to installation with a test pressure of at least 100 psi. Either water or air may be used as the testing medium.

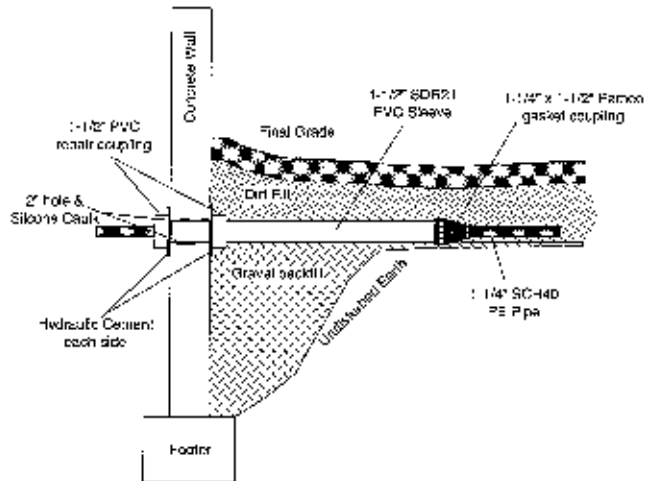

Figure 20 - Below Grade Entry Detail



7300 S.W. 44th Street
Oklahoma City, OK 73179
Phone: 405-745-6000
FAX: 405-745-2051

Part #:69197310

ClimateMaster works continually to improve its products. As a result, the design and specifications of each product at the time for order may be changed without notice and may not be as described herein. Please contact ClimateMaster's Customer Service Department at 1-405-745-6000 for specific information on the current design and specifications. Statements and other information contained herein are not express warranties and do not form the basis of any bargain between the parties, but are merely ClimateMaster's opinion or commendation of its products.