

# TRANQUILITY<sup>®</sup> 16 COMPACT (TC) SERIES



**MODELS TCH/V 006-060  
60HZ - HFC-410A**

**INSTALLATION, OPERATION  
& MAINTENANCE**

**97B0075N07**

**Revised: January 25, 2024**



A **NIBE** GROUP MEMBER

## Table of Contents

Model Nomenclature – General Overview	3
General Information	4
Physical Data	6
Horizontal Installation	7
Field Conversion of Air Discharge	9
Horizontal Installation	10
Vertical Installation	11
Piping Installation	13
Water-Loop Heat Pump Applications	14
Ground-Loop Heat Pump Applications	15
Ground-Water Heat Pump Applications	17
Water Quality Requirements	19
TC: Horizontal – Dimensional Data	23
TCH with WSE – Dimensional Data	25
TC: Horizontal Service Access	27
TC: Vertical Upflow – Dimensional Data	28
TC: Front Return Vertical Upflow – Dimensional Data	30
TCV with WSE – Dimensional Data	31
TC: Vertical Service Access	33
Electrical Data	34
Electrical: Line Voltage	38
Electrical: Power & Low Voltage Wiring	39
Electrical: Low Voltage Wiring	40
Electrical: Thermostat Wiring	41
Blower Performance Data	42
Constant Volume (CV) ECM	54
Constant Torque (CT) ECM	55
Wiring Diagram Matrix	56
DIP Setting Table	57
Controls – CXM2 and DXM2.5	58
Operating and Commissioning Limits	59
Piping System Cleaning and Flushing	60
TC with Waterside Economizer Option	61
Unit and System Checkout	63
Unit Start-Up Procedure	64
Unit Operating Conditions	66
Preventive Maintenance	71
Functional Troubleshooting	72
Performance Troubleshooting	74
Start-Up Log Sheet	75
Functional Troubleshooting Form	76
Warranty (U.S & Canada)	77
Warranty (International)	78
Revision History	80

Tranquility® Compact (TC) Series

Rev.: January 25, 2024

**Table of Contents, Cont'd.**

## Model Nomenclature – General Overview

1 2
3
4 5 6
7
8
9
10
11
12
13
14
15

TC
H
036
A
G
C
3
0
A
P
B
S

**S = STANDARD**

**MODEL TYPE**  
TC = TRANQUILITY COMPACT R410A

**CONFIGURATION**  
H = HORIZONTAL  
V = VERTICAL

**UNIT SIZE**  
006 - E,G  
009 - E,G  
012 - E,G  
015 - E,G  
018 - E,G  
024 - E,F,G,H  
030 - E,F,G,H  
036 - E,F,G,H  
041 - F,G,H,N (TCV ONLY)  
042 - F,G,H,N  
048 - F,G,H,N  
060 - F,G,H,N

**AVAILABLE VOLTAGES**

**REVISION LEVEL**  
A = CURRENT REVISION FOR ALL SIZES

**VOLTAGE**  
G = 208/230/60/1  
E = 265/60/1  
H = 208/230/60/3  
F = 460/60/3  
N = 575/60/3

**CONTROLS**  
C = CXM2  
D = DXM2.5  
N = CXM2 w/MPC  
P = DXM2.5 w/MPC

**w/DISCONNECT**  
A = CXM2  
B = DXM2.5  
R = CXM2 w/MPC  
S = DXM2.5 w/MPC

**SUPPLY AIR OPTIONS**

Option	Supply	Configuration	Motor
T	Top	TCV	PSC
B	Back	TCH	PSC
S	Straight	TCH	PSC
V <sup>1</sup>	Top	TCV	PSC Hi Static
Y <sup>1</sup>	Back	TCH	PSC Hi Static
Z <sup>1</sup>	Straight	TCH	PSC Hi Static
K <sup>2</sup>	Top	TCV	CV ECM
P <sup>2</sup>	Back	TCH	CV ECM
W <sup>2</sup>	Straight	TCH	CV ECM
1 <sup>2</sup>	Top	TCV	CT ECM
2 <sup>2</sup>	Back	TCH	CT ECM
3 <sup>2</sup>	Straight	TCH	CT ECM

<sup>1</sup> Not available for sizes 006, 009, 012, 041  
<sup>2</sup> Not available for size 041  
<sup>3</sup> DXM2.5 Controls Required for CV ECM Fan Motors

**RETURN AIR OPTIONS**  
P = LEFT RETURN  
C = RIGHT RETURN  
S = LEFT RETURN S.S. DRAIN PAN  
T = RIGHT RETURN S.S. DRAIN PAN  
Q = FRONT RETURN S.S. DRAIN PAN and VERTICAL 009-030 AND 041 ONLY

**HEAT EXCHANGER OPTIONS**

OPTION	COPPER WATER COIL	CUPRO-NICKEL WATER COIL	TIN PLATED AIR COIL	E-COATED ECON COIL	WATER SIDE ECONOMIZER
A	YES	NO	YES	N/A	NO
C	YES	NO	NO	N/A	
J	NO	YES	YES	N/A	
N	NO	YES	NO	N/A	
1	YES	NO	YES	YES	YES
2	YES	NO	NO	NO	
3	YES	YES	YES	YES	
4	NO	YES	NO	NO	

**FUTURE USE**  
0 = NONE

**CABINET INSULATION**

OPTION	RANGE	ULTRA QUIET	1" FILTER RAIL	2" FILTER RAIL	1" FILTER FRAME	2" FILTER FRAME
1	EXTENDED RANGE	NO	YES		NO	
A				NO		YES
J			NO	YES		NO
K			NO		YES	NO
2	YES	YES	YES		NO	
C				NO		YES
L			NO	YES		NO
M			NO		YES	NO
3	STANDARD RANGE	NO	YES		NO	
E				NO		YES
N			NO	YES		NO
P			NO		YES	NO
4	YES	YES	YES		NO	YES
G				NO		YES
R			NO	YES		NO
S			NO		YES	NO

Note: Above model nomenclature is a general reference. Not all configurations are available on all models. Consult selection software for detailed information.

Tranquility® Compact (TC) Series

Rev.: January 25, 2024

General Information

Safety

Warnings, cautions, and notices appear throughout this manual. Read these items carefully before attempting any installation, service, or troubleshooting of the equipment.

**DANGER:** Indicates an immediate hazardous situation, which if not avoided will result in death or serious injury. DANGER labels on unit access panels must be observed.

**WARNING:** Indicates a potentially hazardous situation, which if not avoided could result in death or serious injury.

**CAUTION:** Indicates a potentially hazardous situation or an unsafe practice, which if not avoided could result in minor or moderate injury or product or property damage.

**NOTICE:** Notification of installation, operation, or maintenance information, which is important, but which is not hazard-related.

**! WARNING! !**  
**WARNING!** The EarthPure® Application and Service Manual should be read and understood before attempting to service refrigerant circuits with HFC-410A.

**! WARNING! !**  
**WARNING!** To avoid the release of refrigerant into the atmosphere, the refrigerant circuit of this unit must be serviced only by technicians who meet local, state, and federal proficiency requirements.

**! CAUTION! !**  
**CAUTION!** To avoid equipment damage, DO NOT use these units as a source of heating or cooling during the construction process. The mechanical components and filters can quickly become clogged with construction dirt and debris, which may cause system damage and void product warranty.

**! WARNING! !**  
**WARNING!** The installation of water-source heat pumps and all associated components, parts, and accessories which make up the installation shall be in accordance with the regulations of ALL authorities having jurisdiction and MUST conform to all applicable codes. It is the responsibility of the installing contractor to determine and comply with ALL applicable codes and regulations.

**! WARNING! !**  
**WARNING!** Children Being Supervised are NOT to play with the appliance.

**! WARNING! !**

**WARNING!** All refrigerant discharged from this unit must be recovered WITHOUT EXCEPTION. Technicians must follow industry accepted guidelines and all local, state, and federal statutes for the recovery and disposal of refrigerants. If a compressor is removed from this unit, refrigerant circuit oil will remain in the compressor. To avoid leakage of compressor oil, refrigerant lines of the compressor must be sealed after it is removed.

**! WARNING! !**

**WARNING!** This appliance is not intended for use by persons (including children) with reduced physical, sensory, or mental capabilities, or lack of experience and knowledge, unless they have been given supervision or instruction concerning use of the appliance by a person responsible for their safety.

**Inspection** - Upon receipt of the equipment, carefully check the shipment against the bill of lading. Make sure all units have been received. Inspect the packaging of each unit, and inspect each unit for damage. Ensure that the carrier makes proper notation of any shortages or damage on all copies of the freight bill and completes a common carrier inspection report. Concealed damage not discovered during unloading must be reported to the carrier within 15 days of receipt of shipment. If not filed within 15 days, the freight company can deny the claim without recourse.

**Note: It is the responsibility of the purchaser to file all necessary claims with the carrier. Notify your equipment supplier of all damage within fifteen (15) days of shipment.**

**Storage** - Equipment should be stored in its original packaging in a clean, dry area. Store units in an upright position at all times. Stack units a maximum of 3 units high.

**Unit Protection** - Cover units on the job site with either the original packaging or an equivalent protective covering. Cap the open ends of pipes stored on the job site. In areas where painting, plastering, and/or spraying has not been completed, all due precautions must be taken to avoid physical damage to the units and contamination by foreign material. Physical damage and contamination may prevent proper start-up and may result in costly equipment clean-up.

## General Information, Cont'd.

Examine all pipes, fittings, and valves before installing any of the system components. Remove any dirt or debris found in or on these components.

**Pre-Installation** - Installation, Operation, and Maintenance instructions are provided with each unit. Horizontal equipment is designed for installation above false ceiling or in a ceiling plenum. Other unit configurations are typically installed in a mechanical room. The installation site chosen should include adequate service clearance around the unit. Before unit start-up, read all manuals and become familiar with the unit and its operation. Thoroughly check the system before operation.

### Prepare units for installation as follows:

1. Compare the electrical data on the unit nameplate with ordering and shipping information to verify that the correct unit has been shipped.
2. Keep the cabinet covered with the original packaging until installation is complete and all plastering, painting, etc. is finished.
3. Verify refrigerant tubing is free of kinks or dents and that it does not touch other unit components.
4. Inspect all electrical connections. Connections must be clean and tight at the terminals.
5. Remove any blower support packaging (water-to-air units only).
6. Some airflow patterns are field convertible (horizontal units only). Locate the airflow conversion section of this IOM.
7. Locate and verify any hot water generator (HWG), hanger, or other accessory kit located in the compressor section or blower section.

### CAUTION!

**CAUTION!** All three phase scroll compressors must have direction of rotation verified at start-up. Verification is achieved by checking compressor Amp draw. Amp draw will be substantially lower compared to nameplate values. Additionally, reverse rotation results in an elevated sound level compared to correct rotation. Reverse rotation will result in compressor internal overload trip within several minutes. Verify compressor type before proceeding.

### CAUTION!

**CAUTION!** DO NOT store or install units in corrosive environments or in locations subject to temperature or humidity extremes (e.g., attics, garages, rooftops, etc.). Corrosive conditions and high temperature or humidity can significantly reduce performance, reliability, and service life. Always move and store units in an upright position. Tilting units on their sides will cause equipment damage.

### CAUTION!

**CAUTION!** CUT HAZARD - Failure to follow this caution may result in personal injury. Sheet metal parts may have sharp edges or burrs. Use care and wear appropriate protective clothing, safety glasses and gloves when handling parts and servicing heat pumps.

# CLIMATEMASTER WATER-SOURCE HEAT PUMPS

## Tranquility® Compact (TC) Series

Rev.: January 25, 2024

### Physical Data

#### Tranquility® 16 (TC) Series (60 Hz)

TC Series	006	009	012	015	018	024	030	036	041	042	048	060
Compressor (1 Each)	Rotary					Scroll						
Factory Charge HFC-410A (oz)	19	20	23	35	43	40	48	50	70	70	74	82
<b>ECM Fan Motor &amp; Blower</b>												
Blower Wheel Size (Dia x w)	6x5	6x5	6x5	9x7	9x7	9x7	9x7	9x8	N/A	9x8	10x10	12x10
<b>PSC Fan Motor &amp; Blower</b>												
Fan Motor Type/Speeds	PSC/3	PSC/3	PSC-3	PSC/3	PSC/3	PSC/3	PSC/3	PSC/3	PSC/3	PSC/3	PSC/3	PSC/3
Blower Wheel Size (Dia x w)	5x5	5x5	6x5	8x7	8x7	9x7	9x7	9x8	9x8	9x8	10x10	12x10
<b>Water Connection Size</b>												
FPT	1/2"	1/2"	1/2"	1/2"	1/2"	3/4"	3/4"	3/4"	3/4"	3/4"	1"	1"
Coax Volume (gallons)	0.123	0.143	0.167	0.286	0.450	0.286	0.323	0.323	0.890	0.890	0.738	0.939
<b>Vertical</b>												
Air Coil Dimensions (H x W)	10x15	10x15	10x15	20x17.25	20x17.25	20x17.25	20x17.25	24x21.75	20x17.25	24x21.76	24x28.25	24x28.25
Filter Standard - 1" Throwaway	10x18	10x18	10x18	20x20	20x20	20x20	20x20	24x24	20x20	24x24	1-14x24, 1-18x24	1-14x24, 1-18x24
Weight - Operating (lbs.)	103	105	114	153	158	189	197	203	210	218	263	278
Weight - Packaged (lbs.)	113	115	124	158	163	194	202	209	217	224	270	285
<b>Horizontal</b>												
Air Coil Dimensions (H x W)	10x15	10x15	10x15	16x22	16x22	16x22	16x22	20x25	N/A	20x25	20x35	20x35
Filter Standard - 1" Throwaway	10x18	10x18	10x18	16x25	16x25	18x25	18x25	20x28 or 2-20x14	N/A	20x28 or 2-20x14	1-20x24, 1-20x14	1-20x24, 1-20x14
Weight - Operating (lbs.)	103	105	114	153	158	174	182	203	N/A	218	263	278
Weight - Packaged (lbs.)	113	115	124	158	163	179	187	209	N/A	224	270	285

**Notes:**

All units have TXV expansion device, and 1/2" & 3/4" electrical knockouts.

FPT = Female Pipe Thread

Condensate Drain Connection is rubber coupling that couples to 3/4" schedule 40/80 PVC.

575 volt fan motors are two speed.

Unit Maximum Water Working Pressure	Max Pressure PSIG [kPa]
Base Unit	500 [3447]
WSE Option	300 [2068]

Use the lowest maximum pressure rating that applies to your unit.

## Horizontal Installation

### Horizontal Unit Location

Units are not designed for outdoor installation. Locate the unit in an INDOOR area that allows enough space for service personnel to perform typical maintenance or repairs without removing unit from the ceiling. Horizontal units are typically installed above a false ceiling or in a ceiling plenum. Never install units in areas subject to freezing or where humidity levels could cause cabinet condensation (such as unconditioned spaces subject to 100% outside air). Consideration should be given to access for easy removal of the filter and access panels. Provide sufficient room to make water, electrical, and duct connection(s).

If the unit is located in a confined space, such as a closet, provisions must be made for return air to freely enter the space by means of a louvered door, etc. Any access panel screws that would be difficult to remove after the unit is installed should be removed prior to setting the unit. Refer to Figure 3 for an illustration of a typical installation. Refer to unit submittal data or engineering design guide for dimensional data.

### Conform to the following guidelines when selecting unit location:

1. Provide a hinged access door in concealed-spline or plaster ceilings. Provide removable ceiling tiles in T-bar or lay-in ceilings. Refer to horizontal unit dimensions for specific series and model in unit submittal data. Size the access opening to accommodate the service technician during the removal or replacement of the compressor, control, or blower assembly.
2. Provide access to hanger brackets, water valves and fittings. Provide screwdriver clearance to access panels, discharge collars and all electrical connections.
3. DO NOT obstruct the space beneath the unit with piping, electrical cables and other items that prohibit future removal of components or the unit itself.
4. Use a manual portable jack/lift to lift and support the weight of the unit during installation and servicing.

The installation of water source heat pump units and all associated components, parts and accessories which make up the installation shall be in accordance with the regulations of ALL authorities having jurisdiction and MUST conform to all applicable codes. It is the responsibility of the installing contractor to determine and comply with ALL applicable codes and regulations.

### Mounting Horizontal Units

Horizontal units have 4 hanger brackets partially attached at the factory, one at each corner. Enclosed within the unit there is a hanger kit hardware bag containing vibration isolation grommets, washers, screws and a hanger installation instruction page. One additional screw from the hardware bag must be added to each hanger bracket before unit installation. Tighten each screw to 75 in-lbs (8.5 Nm). See Figure 1. Refer to the hanger installation instruction page contained in the hardware bag for details of final hanger bracket attachment and unit suspension. See Figure 1a.

Use four (4) field supplied threaded rods and factory provided vibration isolators to suspend the unit. Safely lift the unit into position supporting the bottom of the unit. Ensure the top of the unit is not in contact with any external objects. Connect the top end of the 4 all-thread rods, slide rods through the brackets and grommet then assemble washers and double nuts at each rod. Ensure that the unit is approximately level and that the threaded rod extends past the nuts.

Pitch the unit toward the drain as shown in Figure 2 to improve the condensate drainage. On small units (less than 2.5 tons/8.8kW) ensure that unit pitch does not cause condensate leaks inside the cabinet.

Figure 1: Hanger Bracket

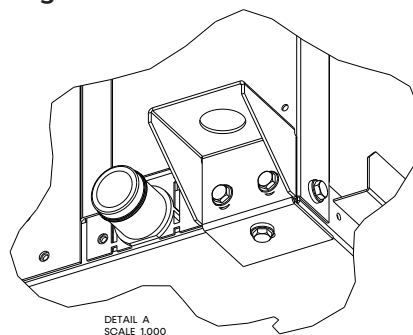
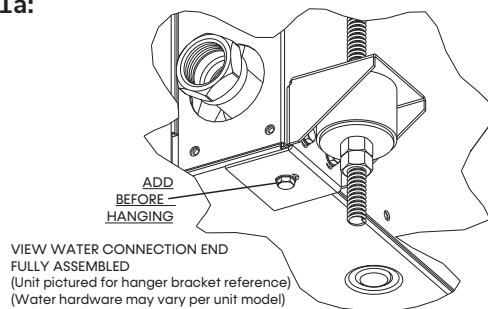

Figure 1a:



Tranquility® Compact (TC) Series

Rev.: January 25, 2024

Horizontal Installation, Cont'd.

Figure 2: Horizontal Unit Pitch

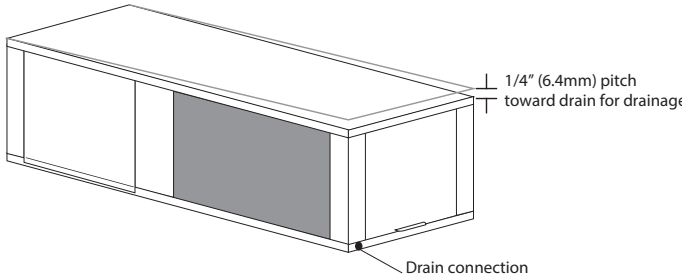
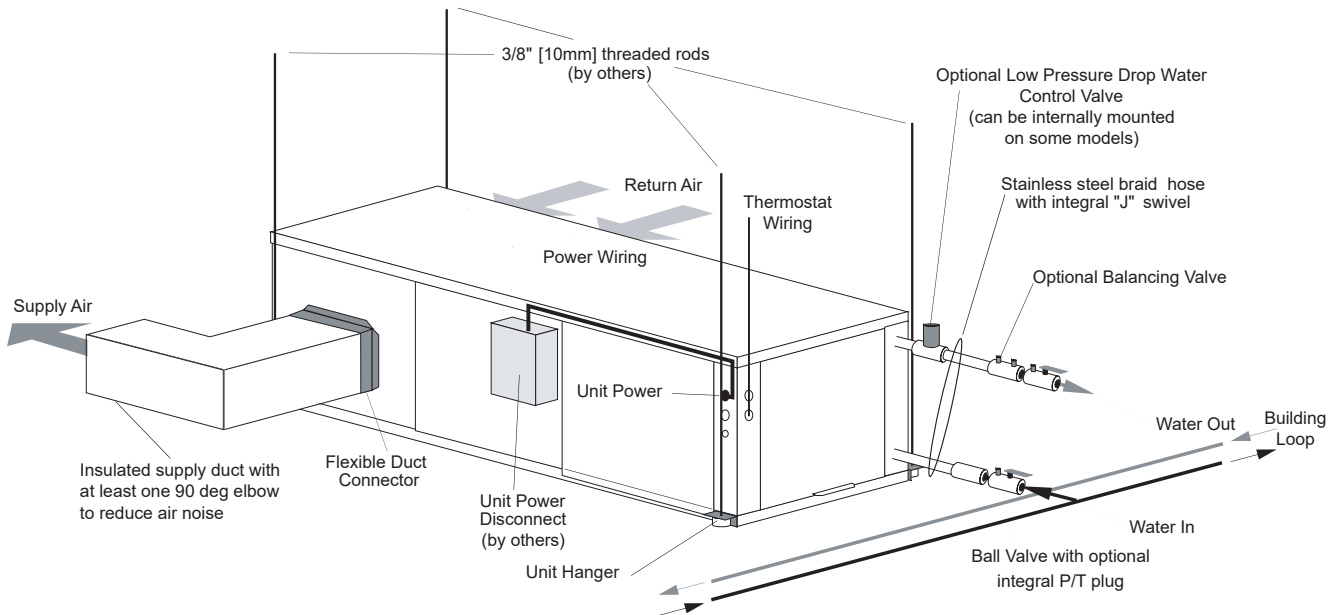

Figure 3: Typical Horizontal Unit Installation



**Air Coil** - To obtain maximum performance, the air coil should be cleaned before start-up. A 10% solution of dishwasher detergent and water is recommended for both sides of the coil. A thorough water rinse should follow. **UV based anti-bacterial systems may damage e-coated air coils.**

**Notice!** Installation Note - Ducted Return: Many horizontal WSHPs are installed in a return air ceiling plenum application (above ceiling). Vertical WSHPs are commonly installed in a mechanical room with free return (e.g. louvered door). Therefore, filter rails are the industry standard and are included on ClimateMaster commercial heat pumps for the purposes of holding the filter only. For ducted return applications, the filter rail must be removed and replaced with a duct flange or filter frame. Canvas or flexible connectors should also be used to minimize vibration between the unit and ductwork.

## Horizontal Installation – Field Conversion of Air Discharge

**Overview** - Horizontal units can be field converted between side (straight) and back (end) discharge using the instructions below.

**NOTE:** It is not possible to field convert return air between left or right return models due to the necessity of refrigeration copper piping changes.

**Preparation** - It is best to field convert the unit on the ground before hanging. If the unit is already hung it should be taken down for the field conversion.

### Side to Back Discharge Conversion

1. Place unit in well lit area. Remove the screws as shown in Figure 4 to free top panel and discharge panel.
2. Lift out the access panel and set aside. Lift and rotate the discharge panel to the other position as shown, being careful with the blower wiring.
3. Check blower wire routing and connections for tension or contact with sheet metal edges. Re-route if necessary.
4. Check refrigerant tubing for contact with other components.
5. Reinstall top panel and screws noting that the location for some screws will have changed.
6. Manually spin the fan wheel to ensure that the wheel is not rubbing or obstructed.
7. Replace access panels.

**Back to Side Discharge Conversion** - If the discharge is changed from back to side, use above instruction noting that illustrations will be reversed.

**Left vs. Right Return** - It is not possible to field convert return air between left or right return models due to the necessity of refrigeration copper piping changes. However, the conversion process of side to back or back to side discharge for either right or left return configuration is the same. In some cases, it may be possible to rotate the entire unit 180 degrees if the return air connection needs to be on the opposite side. **Note that rotating the unit will move the piping to the other end of the unit.**

Figure 4: Left Return Side to Back

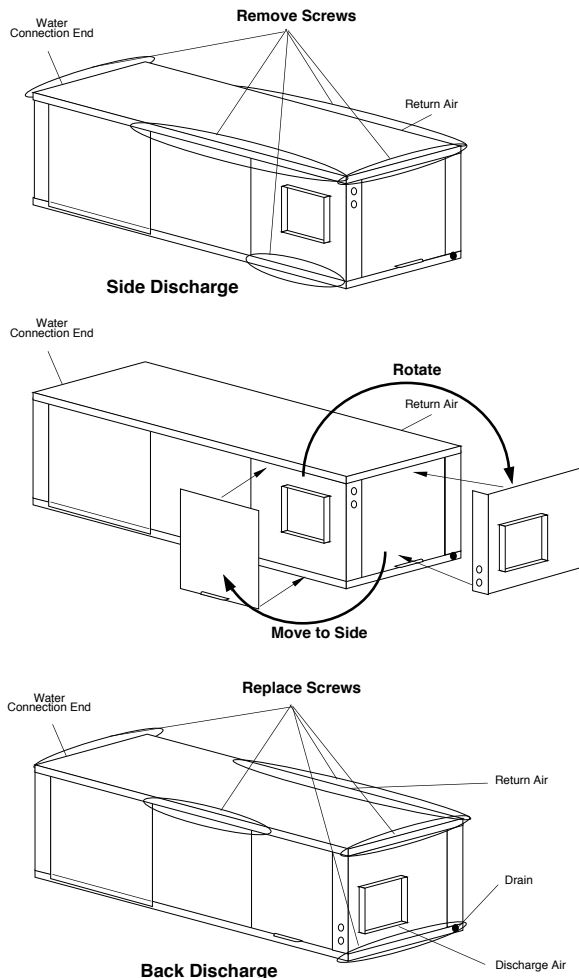
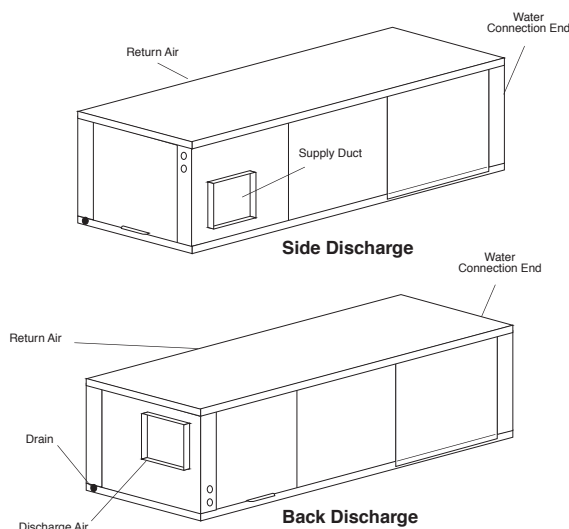

Figure 5: Right Return Side to Back



## Tranquility® Compact (TC) Series

Rev.: January 25, 2024

### Horizontal Installation, Cont'd.

**Condensate Piping - Horizontal Units** - A condensate drain line must be installed and pitched away for the unit to allow for proper drainage. This connection must meet all local plumbing/building codes.

Pitch the unit toward the drain as shown in Figure 2 to improve the condensate drainage. On small units (less than 2.5 tons/8.8 kW), ensure that unit pitch does not cause condensate leaks inside the cabinet.

Install condensate trap at each unit with the top of the trap positioned below the unit condensate drain connection as shown in Figure 6. Design the depth of the trap (water-seal) based upon the amount of ESP capability of the blower (where 2 inches [51mm] of ESP capability requires 2 inches [51mm] of trap depth). As a general rule, 1-1/2 inch [38mm] trap depth is the minimum.

Models with Water Side Economizer (Model Digit 12 is 1-4) Must trap WSE same as unit, can join together after vent.

Each unit must be installed with its own individual trap and connection to the condensate line (main) or riser. Provide a means to flush or blow out the condensate line. DO NOT install units with a common trap and/or vent.

Always vent the condensate line when dirt or air can collect in the line or a long horizontal drain line is required. Also vent when large units are working against higher external static pressure than other units connected to the same condensate main since this may cause poor drainage for all units on the line. **WHEN A VENT IS INSTALLED IN THE DRAIN LINE, IT MUST BE LOCATED AFTER THE TRAP IN THE DIRECTION OF THE CONDENSATE FLOW.**

**Polymer Drain Pans** - condensate drain connection is a rubber coupling that connects to 3/4" schedule 40/80 PVC. Use hose clamps to secure the pipe inside the coupling. If the connection is not secure, the connection may leak.

Instructions for coupling the condensate drain to the trap are included in the bag that includes the coupling and hose clamps.

**Stainless Steel Drain Pans** - condensate connection is male-pipe thread. Field to provide female condensate connection adapter.

**Duct System Installation** - Proper duct sizing and design is critical to the performance of the unit. The duct system should be designed to allow adequate and even airflow through the unit during operation. Air flow through the unit **MUST** be at or above the minimum stated airflow for the unit to avoid equipment damage. Duct systems should be designed for quiet operation. Refer to Figure 3 for horizontal duct system details or Figure 8 for vertical duct system details. A flexible connector is recommended for both discharge and return air duct connections on metal duct systems to eliminate the transfer of vibration to the duct system. To maximize sound attenuation of the unit blower, the supply and return plenums should include internal fiberglass duct liner or be constructed from ductboard for the first few feet. Application of the unit to uninsulated ductwork in an unconditioned space is not recommended, as the unit's performance may be adversely affected.

At least one 90° elbow should be included in the supply duct to reduce air noise. If air noise or excessive air flow is a problem, the blower speed can be changed. For airflow charts, consult submittal data for the series and model of the specific unit.

If the unit is connected to existing ductwork, a previous check should have been made to ensure that the ductwork has the capacity to handle the airflow required for the unit. If ducting is too small, as in the replacement of a heating only system, larger ductwork should be installed. All existing ductwork should be checked for leaks and repaired as necessary.

⚠ **CAUTION!** ⚠

**CAUTION!** Ensure condensate line is pitched toward drain 1/8 inch per ft [11 mm per m] of run.

**Figure 6: Horizontal Condensate Connection**

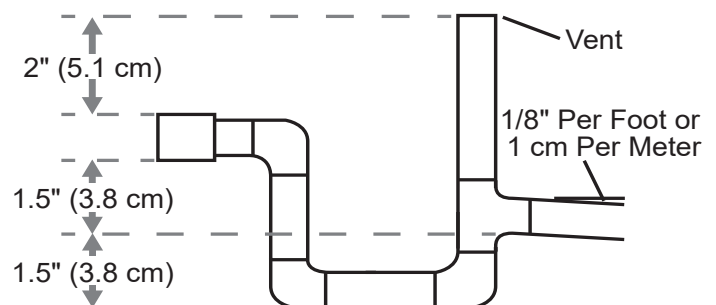

## Vertical Installation

**Vertical Unit Location** - Units are not designed for outdoor installation. Locate the unit in an INDOOR area that allows enough space for service personnel to perform typical maintenance or repairs without removing unit from the mechanical room/closet. Vertical units are typically installed in a mechanical room or closet. Never install units in areas subject to freezing or where humidity levels could cause cabinet condensation (such as unconditioned spaces subject to 100% outside air). Consideration should be given to access for easy removal of the filter and access panels. Provide sufficient room to make water, electrical, and duct connection(s).

If the unit is located in a confined space, such as a closet, provisions must be made for return air to freely enter the space by means of a louvered door, etc. Any access panel screws that would be difficult to remove after the unit is installed should be removed prior to setting the unit. Refer to Figures 7 and 8 for typical installation illustrations. Refer to unit submittal data or engineering design guide for dimensional data.

1. Install the unit on a piece of rubber, neoprene or other mounting pad material for sound isolation. The pad should be at least 3/8" [10mm] to 1/2" [13mm] in thickness. Extend the pad beyond all four edges of the unit.
2. Provide adequate clearance for filter replacement and drain pan cleaning. Do not block filter access with piping, conduit or other materials. Refer to unit submittal data or engineering design guide for dimensional data.
3. Provide access for fan and fan motor maintenance and for servicing the compressor and coils without removing the unit.
4. Provide an unobstructed path to the unit within the closet or mechanical room. Space should be sufficient to allow removal of the unit, if necessary.
5. In limited side access installations, pre-removal of the control box side mounting screws will allow control box removal for future servicing.
6. Provide access to water valves and fittings and screwdriver access to the unit side panels, discharge collar and all electrical connections.

**Figure 7: Vertical Unit Mounting**

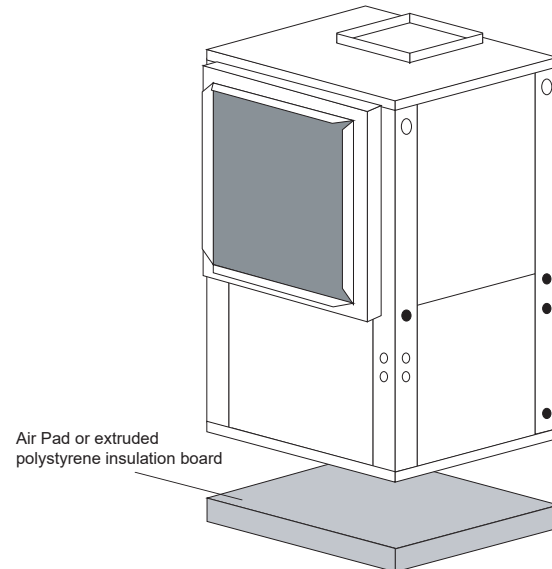

**Figure 8: Typical Vertical Unit Installation Using Ducted Return Air**

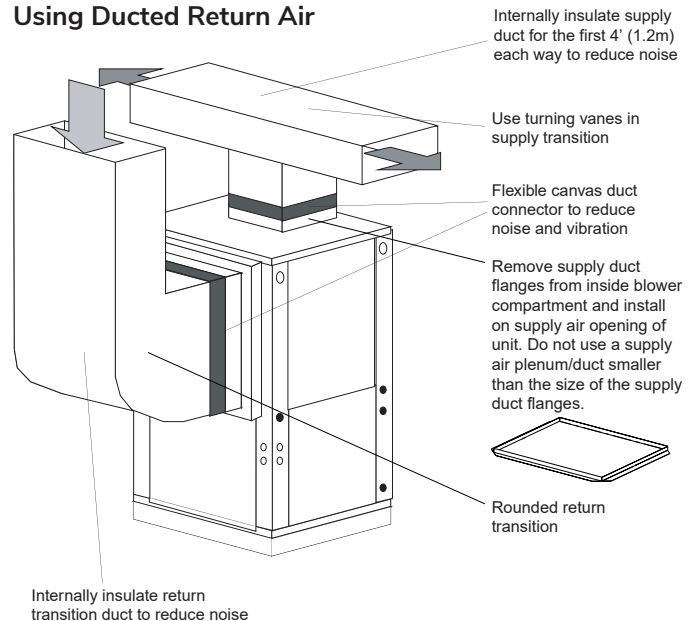

**Notice!** Installation Note - Ducted Return: Many horizontal WSHPs are installed in a return air ceiling plenum application (above ceiling). Vertical WSHPs are commonly installed in a mechanical room with free return (e.g. louvered door). Therefore, filter rails are the industry standard and are included on ClimateMaster commercial heat pumps for the purposes of holding the filter only. For ducted return applications, the filter rail must be removed and replaced with a duct flange or filter frame. Canvas or flexible connectors should also be used to minimize vibration between the unit and ductwork.

## Tranquility® Compact (TC) Series

Rev.: January 25, 2024

## Vertical Installation, Cont'd.

**Sound Attenuation for Vertical Units** - Sound attenuation is achieved by enclosing the unit within a small mechanical room or a closet. Additional measures for sound control include the following:

1. Mount the unit so that the return air inlet is 90° to the return air grille. Refer to Figure 9. Install a sound baffle as illustrated to reduce line-of-sight sound transmitted through return air grilles.
2. Mount the unit on a rubber or neoprene isolation pad to minimize vibration transmission to the building structure.

**Figure 9: Vertical Sound Attenuation**

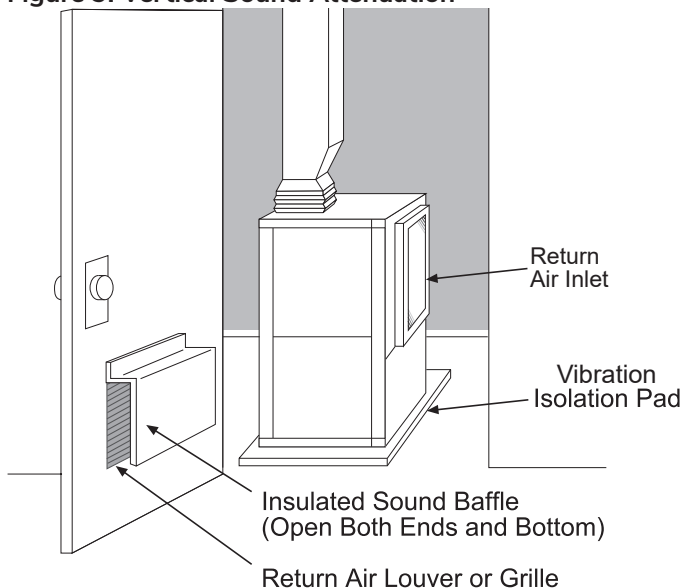

**Notice! Units with clear plastic drain lines should have regular maintenance (as required) to avoid buildup of debris, especially in new construction.**

**Condensate Piping for Vertical Units** - A condensate line must be installed and pitched away from the unit to allow for proper drainage. This connection must meet all local plumbing/building codes.

Install condensate trap at each unit with the top of the trap positioned below the unit condensate drain connection as shown in Figure 6. Design the depth of the trap (water-seal) based upon the amount of ESP capability of the blower (where 2 inches [51mm] of ESP capability requires 2 inches [51mm] of trap depth). As a general rule, 1-1/2 inch [38mm] trap depth is the minimum.

Always vent the condensate line when dirt or air can collect in the line or a long horizontal drain line is required. Also vent when large units are working against higher external static pressure than other units connected to the same condensate main since this may cause poor drainage for all units on the line. **WHEN A VENT IS INSTALLED IN THE DRAIN LINE, IT MUST BE LOCATED AFTER THE TRAP IN THE DIRECTION OF THE CONDENSATE FLOW.**

Each unit must be installed with its own individual vent (where necessary) and a means to flush or blow out the condensate drain line. Do not install units with a common trap and/or vent.

Condensate drain connection is a rubber coupling that couples to 3/4" schedule 40/80 PVC. Use hose clamps to secure the pipe inside the coupling. If the connection is not secure, the connection may leak.

Instructions for coupling the condensate drain to the trap are included in the bag that includes the coupling and hose clamps.

## Piping Installation

### Installation of Supply and Return Piping

Follow these piping guidelines.

1. Install a drain valve at the base of each supply and return riser to facilitate system flushing.
2. Install shut-off / balancing valves and unions at each unit to permit unit removal for servicing.
3. Place strainers at the inlet of each system circulating pump.
4. Select the proper hose length to allow slack between connection points. Hoses may vary in length by +2% to -4% under pressure.
5. Refer to Table 1. Do not exceed the minimum bend radius for the hose selected. Exceeding the minimum bend radius may cause the hose to collapse, which reduces water flow rate. Install an angle adapter to avoid sharp bends in the hose when the radius falls below the required minimum.

Insulation is not required on loop water piping except where the piping runs through unheated areas, outside the building or when the loop water temperature is below the minimum expected dew point of the pipe ambient conditions. Insulation is required if loop water temperature drops below the dew point (insulation is required for ground loop applications in most climates).

Pipe joint compound is not necessary when Teflon® thread tape is pre-applied to hose assemblies or when flared-end connections are used. If pipe joint compound is preferred, use compound only in small amounts on the external pipe threads of the fitting adapters. Prevent sealant from reaching the flared surfaces of the joint.

**Note: When antifreeze is used in the loop, ensure that it is compatible with the Teflon® tape or pipe joint compound that is applied.**

Maximum allowable torque for brass fittings is 30 ft-lbs [41 N-m]. If a torque wrench is not available, tighten finger-tight plus one quarter turn. Tighten steel fittings as necessary.

Models with Waterside Economizer Option (Model Digit 12 is 1-4) - Field fabricate water piping to connect WSE out to unit in. Allow room to remove front access panel and service unit. Insulate pipe. Hoses are not recommended due to high pressure drop.

Optional pressure-rated hose assemblies designed specifically for use with ClimateMaster units are available. Similar hoses can be obtained from alternate suppliers.

Supply and return hoses are fitted with swivel-joint fittings at one end to prevent kinking during installation. Refer to Figure 13 for an illustration of a typical supply/return hose kit. Adapters secure hose assemblies to the unit and risers. Install hose assemblies properly and check regularly to avoid system failure and reduced service life.

A backup wrench is required when tightening water connections on TC Series units to prevent water line damage.

**! WARNING! !**

**WARNING!** Polyolester Oil, commonly known as POE oil, is a synthetic oil used in many refrigeration systems including those with HFC-410A refrigerant. POE oil, if it ever comes in contact with PVC or CPVC piping, may cause failure of the PVC/CPVC. PVC/CPVC piping should never be used as supply or return water piping with water source heat pump products containing HFC-410A as system failures and property damage may result.

**! CAUTION! !**

**CAUTION!** Corrosive system water requires corrosion resistant fittings and hoses, and may require water treatment.

**! CAUTION! !**

**CAUTION!** Do not bend or kink supply lines or hoses.

**! CAUTION! !**

**CAUTION!** Piping must comply with all applicable codes.

Table 1: Metal Hose Minimum Bend Radii

Hose Diameter	Minimum Bend Radii
1/2" [12.7mm]	2-1/2" [6.4cm]
3/4" [19.1mm]	4" [10.2cm]
1" [25.4mm]	5-1/2" [14cm]
1-1/4" [31.8mm]	6-3/4" [17.1cm]

**NOTICE! Do not allow hoses to rest against structural building components. Compressor vibration may be transmitted through the hoses to the structure, causing unnecessary noise complaints.**

Figure 10: Supply/Return Hose Kit

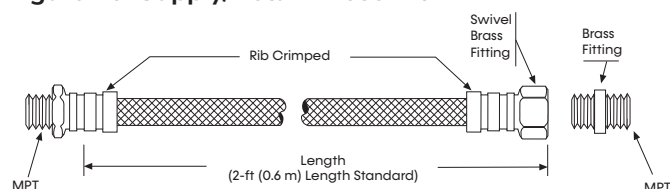

Tranquility® Compact (TC) Series

Rev.: January 25, 2024

Water-Loop Heat Pump Applications

Commercial Water Loop Applications

Commercial systems typically include a number of units connected to a common piping system. Any unit plumbing maintenance work can introduce air into the piping system; therefore air elimination equipment is a major portion of the mechanical room plumbing. Consideration should be given to insulating the piping surfaces to avoid condensation. ClimateMaster recommends unit insulation any time the water temperature is expected to be below 60°F (15.6°C). Metal to plastic threaded joints should never be used due to their tendency to leak over time.

Teflon® tape thread sealant is recommended to minimize internal fouling of the heat exchanger. Do not over tighten connections and route piping so as not to interfere with service or maintenance access. Hose kits are available from ClimateMaster in different configurations as shown in Figure 11 for connection between the unit and the piping system. Depending upon selection, hose kits may include shut off valves, P/T plugs for performance measurement, high pressure stainless steel braided hose, “Y” type strainer with blow down valve, and/or “J” type

swivel connection. Balancing valves and an external low pressure drop solenoid valve for use in variable speed pumping systems may also be included in the hose kit.

The piping system should be flushed to remove dirt, piping chips, and other foreign material prior to operation (see “Piping System Cleaning and Flushing Procedures” in this manual). The flow rate is usually set between 2.25 and 3.5 gpm per ton [2.9 and 4.5 l/m per kW] of cooling capacity. ClimateMaster recommends 3 gpm per ton [3.9 l/m per kW] for most applications of water loop heat pumps. To ensure proper maintenance and servicing, P/T ports are imperative for temperature and flow verification, as well as performance checks.

Water loop heat pump (cooling tower/boiler) systems typically utilize a common loop, maintained between 60 - 90°F [16 - 32°C]. The use of a closed circuit evaporative cooling tower with a secondary heat exchanger between the tower and the water loop is recommended. If an open type cooling tower is used continuously, chemical treatment and filtering will be necessary.

Figure 11: Typical Water-Loop Application

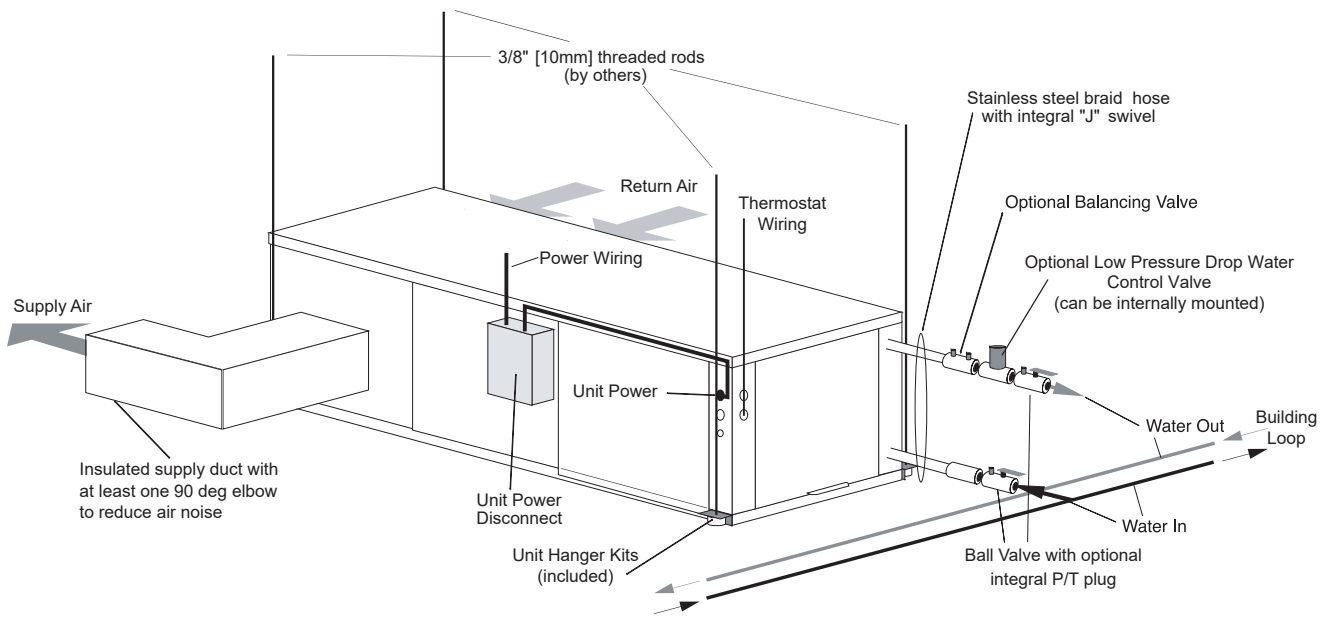

Low Water Temperature Cutout Setting - CXM2 Control

When antifreeze is selected, the LT1 jumper (JW3) should be clipped to select the low temperature (antifreeze 10.0°F [-12.2°C]) setpoint and avoid nuisance faults (see “Low

Water Temperature Cutout Selection” in this manual).

**NOTE: Low water temperature operation requires extended range equipment.**

## Ground-Loop Heat Pump Applications

### ⚠ CAUTION! ⚠

**CAUTION!** The following instructions represent industry accepted installation practices for closed loop earth coupled heat pump systems. Instructions are provided to assist the contractor in installing trouble free ground loops. These instructions are recommendations only. State/provincial and local codes **MUST** be followed and installation **MUST** conform to **ALL** applicable codes. It is the responsibility of the installing contractor to determine and comply with **ALL** applicable codes and regulations.

### ⚠ CAUTION! ⚠

**CAUTION!** Ground loop applications require extended range equipment and optional refrigerant/water circuit insulation.

#### Pre-Installation

Prior to installation, locate and mark all existing underground utilities, piping, etc. Install loops for new construction before sidewalks, patios, driveways, and other construction has begun. During construction, accurately mark all ground loop piping on the plot plan as an aid in avoiding potential future damage to the installation.

#### Piping Installation

The typical closed loop ground source system is shown in Figure 11. All earth loop piping materials should be limited to polyethylene fusion only for in-ground sections of the loop. Galvanized or steel fittings should not be used at any time due to their tendency to corrode. All plastic to metal threaded fittings should be avoided due to their potential to leak in earth coupled applications. A flanged fitting should be substituted. P/T plugs should be used so that flow can be measured using the pressure drop of the unit heat exchanger.

Earth loop temperatures can range between 25 and 110°F [-4 to 43°C]. Flow rates between 2.25 and 3 gpm [2.41 to 3.23 l/m per kW] of cooling capacity is recommended in these applications.

Test individual horizontal loop circuits before backfilling. Test vertical U-bends and pond loop assemblies prior to installation. Pressures of at least 100 psi [689 kPa] should be used when testing. Do not exceed the pipe pressure rating. Test entire system when all loops are assembled.

#### Flushing the Earth Loop

Upon completion of system installation and testing, flush the system to remove all foreign objects and purge to remove all air.

#### Antifreeze

In areas where minimum entering loop temperatures drop below 40°F [5°C] or where piping will be routed through areas subject to freezing, antifreeze is required. Alcohols and glycols are commonly used as antifreeze; however your local sales office should be consulted to determine the antifreeze best suited to your area. Freeze protection should be maintained to 15°F [9°C] below the lowest expected entering loop temperature. For example, if 30°F [-1°C] is the minimum expected entering loop temperature, the leaving loop temperature would be 22 to 25°F [-6 to -4°C] and freeze protection should be at 15°F [-10°C].

Calculation is as follows:

$$30^{\circ}\text{F} - 15^{\circ}\text{F} = 15^{\circ}\text{F} \quad [-1^{\circ}\text{C} - 9^{\circ}\text{C} = -10^{\circ}\text{C}]$$

All alcohols should be premixed and pumped from a reservoir outside of the building when possible or introduced under the water level to prevent fumes. Calculate the total volume of fluid in the piping system. Then use the percentage by volume shown in Table 2 for the amount of antifreeze needed. Antifreeze concentration should be checked from a well mixed sample using a hydrometer to measure specific gravity.

#### Low Water Temperature Cutout Setting - CXM2 Control

When antifreeze is selected, the LT1 jumper (JW3) should be clipped to select the low temperature (antifreeze 10.0°F [-12.2°C]) setpoint and avoid nuisance faults (see “Low Water Temperature Cutout Selection” in this manual).

**NOTE: Low water temperature operation requires extended range equipment.**

Table 2: Antifreeze Percentages by Volume

Type	Minimum Temperature for Low Temperature Protection			
	10°F [-12.2°C]	15°F [-9.4°C]	20°F [-6.7°C]	25°F [-3.9°C]
Methanol	25%	21%	16%	10%
100% USP food grade Propylene Glycol	38%	25%	22%	15%
Ethanol*	29%	25%	20%	14%

\* Must not be denatured with any petroleum based product

Tranquility® Compact (TC) Series

Rev.: January 25, 2024

Ground-Loop Heat Pump Applications, Cont'd.

Figure 12: Typical Ground-Loop Application

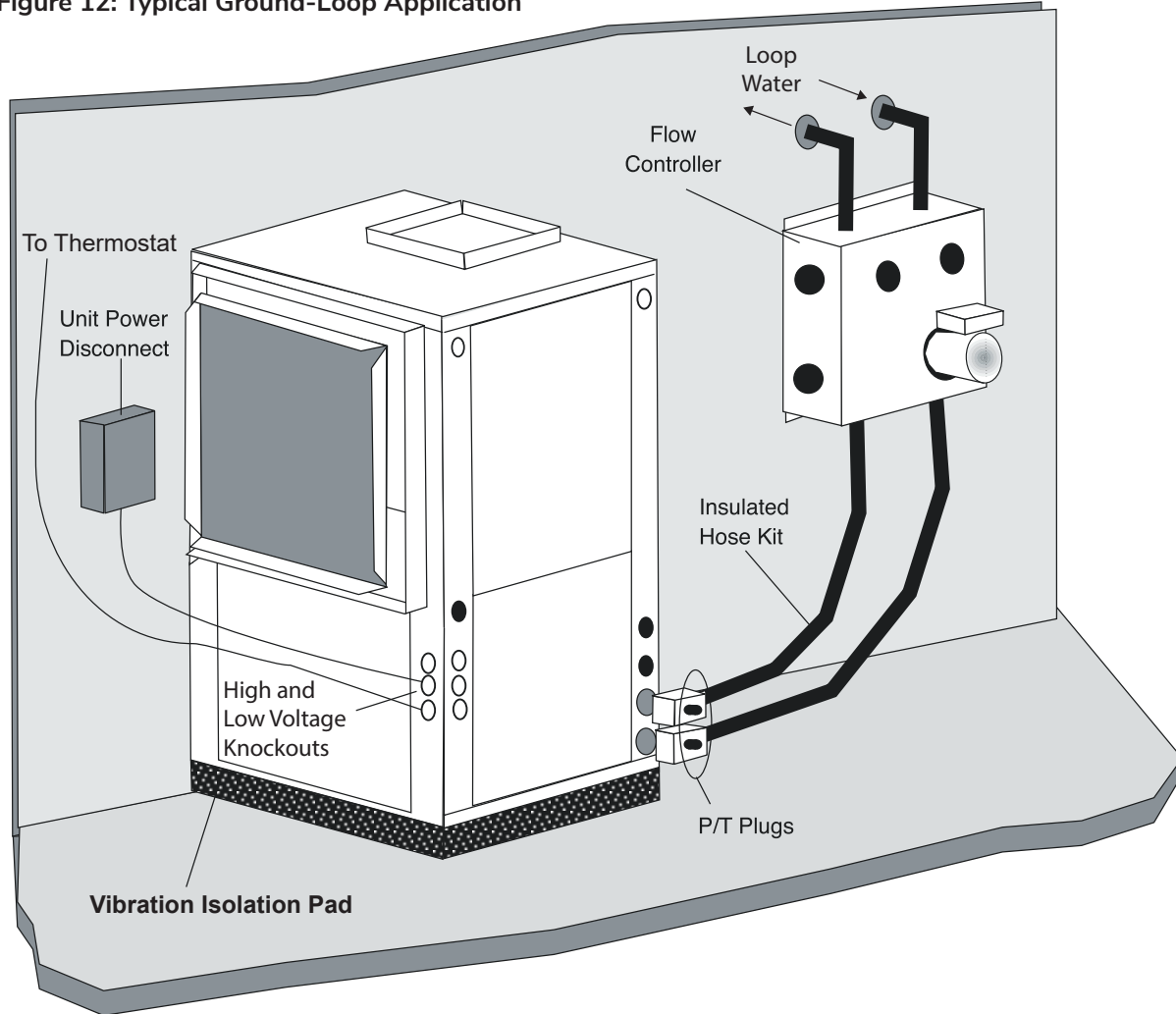

## Ground-Water Heat Pump Applications

**Open Loop - Ground Water Systems** - Typical open loop piping is shown in Figure 13. Shut off valves should be included for ease of servicing. Boiler drains or other valves should be “tee'd” into the lines to allow acid flushing of the heat exchanger. Shut off valves should be positioned to allow flow through the coax via the boiler drains without allowing flow into the piping system. P/T plugs should be used so that pressure drop and temperature can be measured. Supply and return water piping materials should be limited to copper, PE, or similar material. PVC or CPVC should never be used as they are incompatible with the POE oils used in HFC-410A products and piping system failure and property damage may result.

**Water Quality Requirements** - Table 3 should be consulted for water quality requirements. Scaling potential should be assessed using the pH/Calcium hardness method. If the pH <7.5 and the calcium hardness is less than 100 ppm, scaling potential is low. If this method yields numbers out of range of those listed, the Ryznar Stability and Langelier Saturation indices should be calculated. Use the appropriate scaling surface temperature for the application, 150°F [66°C] for direct use (well water/open loop); 90°F [32°F] for indirect use. A monitoring plan should be implemented in these probable scaling situations. Other water quality issues such as iron fouling, corrosion prevention and erosion and clogging should be referenced in Table 3.

### **WARNING!**

**WARNING!** Polyolester Oil, commonly known as POE oil, is a synthetic oil used in many refrigeration systems including those with HFC-410A refrigerant. POE oil, if it ever comes in contact with PVC or CPVC piping, may cause failure of the PVC/CPVC. PVC/CPVC piping should never be used as supply or return water piping with water source heat pump products containing HFC-410A as system failures and property damage may result.

Water quantity should be plentiful and of good quality. Consult table 3 for water quality guidelines. The unit can be ordered with either a copper or cupro-nickel water heat exchanger. Consult Table 3 for recommendations. Copper is recommended for closed loop systems and open loop ground water systems that are not high in mineral content or corrosiveness. In conditions anticipating heavy scale formation or in brackish water, a cupro-nickel heat exchanger is recommended. In ground water situations where scaling could be heavy or where biological growth such as iron bacteria will be present, an open loop system is not recommended. Heat exchanger coils may over time lose heat exchange capabilities due to build up of mineral deposits. Heat exchangers must only be serviced by a qualified technician, as acid and special pumping equipment is required. Desuperheater coils can likewise become scaled and possibly plugged. In areas with extremely hard water, the owner should be informed that the heat exchanger may require occasional acid flushing. In some cases, the desuperheater option should not be recommended due to hard water conditions and additional maintenance required.

**Expansion Tank and Pump** - Use a closed, bladder-type expansion tank to minimize mineral formation due to air exposure. The expansion tank should be sized to provide at least one minute continuous run time of the pump using its drawdown capacity rating to prevent pump short cycling. Discharge water from the unit is not contaminated in any manner and can be disposed of in various ways, depending on local building codes (e.g. recharge well, storm sewer, drain field, adjacent stream or pond, etc.). Most local codes forbid the use of sanitary sewer for disposal. Consult your local building and zoning department to assure compliance in your area.

**Water Control Valve** - Note the placement of the water control valve in Figure 13. Always maintain water pressure in the heat exchanger by placing the water control valve(s) on the discharge line to prevent mineral precipitation during the off-cycle. Pilot operated slow closing valves are recommended to reduce water hammer. If water hammer persists, a mini-expansion tank can be mounted on the piping to help absorb the excess hammer shock. Ensure that the total 'VA' draw of the valve can be supplied by the unit transformer. For instance, a slow closing valve can draw up to 35VA. This can overload smaller 50 VA transformers depending on the other controls in the circuit. A typical pilot operated solenoid valve draws approximately 15VA (see Figure 18). Note the special wiring diagrams for slow closing valves (Figures 18 & 19).

Tranquility® Compact (TC) Series

Rev.: January 25, 2024

Ground-Water Heat Pump Applications, Cont'd.

**Flow Regulation** - Flow regulation can be accomplished by two methods. One method of flow regulation involves simply adjusting the ball valve or water control valve on the discharge line. Measure the pressure drop through the unit heat exchanger, and determine flow rate from Tables 8a through 8e. Since the pressure is constantly varying, two pressure gauges may be needed. Adjust the valve until the desired flow of 1.5 to 2 gpm per ton [2.0 to 2.6 l/m per kW] is achieved. A second method of flow control requires a flow control device mounted on the outlet of the water control valve. The device is typically a brass fitting with an orifice of rubber or plastic material that is designed to allow a specified flow rate. On occasion, flow control devices may produce velocity noise that can be

reduced by applying some back pressure from the ball valve located on the discharge line. Slightly closing the valve will spread the pressure drop over both devices, lessening the velocity noise.

**Note: When EWT is below 50°F [10°C], 2 gpm per ton (2.6 l/m per kW) is required.**

**Water Coil Low Temperature Limit Setting** - For all open loop systems the 30°F [-1.1°C] FP1 setting (factory setting-water) should be used to avoid freeze damage to the unit. See “Low Water Temperature Cutout Selection” in this manual for details on the low limit setting.

Figure 13: Typical Open Loop/Well Application

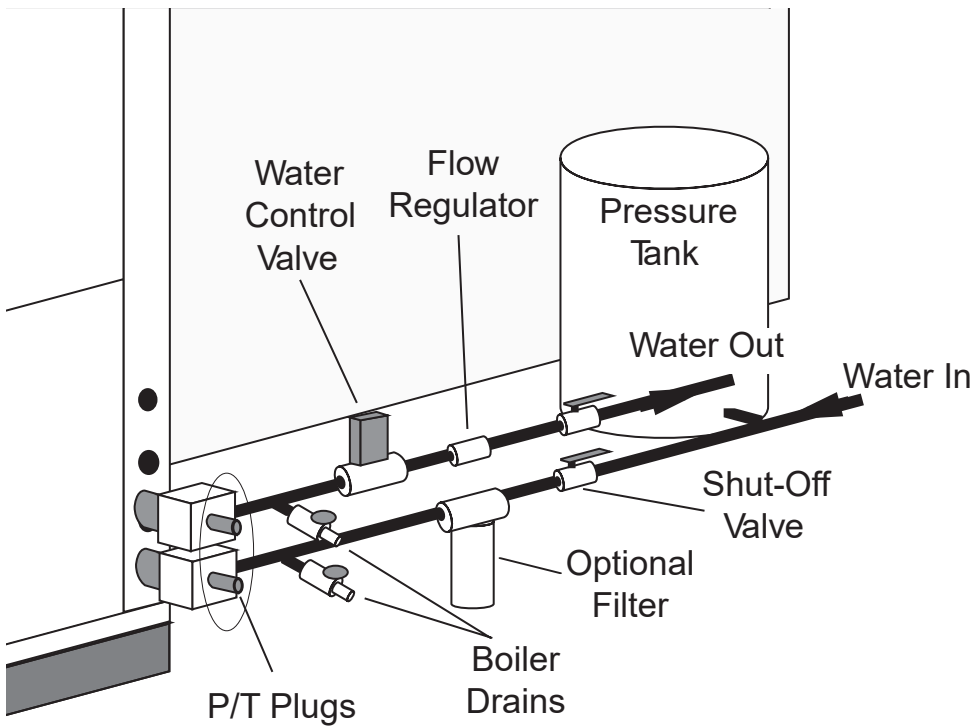

## Water Quality Requirements

**Table 3: Water Quality Requirements**

Clean water is essential to the performance and life span of water source heat pumps. Contaminants, chemicals, and minerals all have the potential to cause damage to the water heat exchanger if not treated properly. All closed water loop systems should undergo water quality testing and be maintained to the water quality requirements listed in this table.

WATER QUALITY REQUIREMENTS							
For Closed-Loop and Open-Loop Systems							
	Description	Symbol	Units	Heat Exchanger Type			
				Closed Loop Recirculating	Open Loop, Tower, Ground Source Well		
				All Heat Exchanger Types	COAXIAL HX Copper Tube in Tube	COAXIAL HX Cupronickel	Brazed Plate HX 316 SS
Scaling Potential	pH - Chilled Water <85°F			7.0 to 9.0	7.0 to 9.0	7.0 to 9.0	7.0 to 9.0
	pH - Heated Water >85°F			8.0 to 10.0	8.0 to 10.0	8.0 to 10.0	8.0 to 10.0
	Alkalinity	(HCO <sub>3</sub> <sup>-</sup> )	ppm - CaCO <sub>3</sub> equiv.	50 to 500	50 to 500	50 to 500	50 to 500
	Calcium	(Ca)	ppm	<100	<100	<100	<100
	Magnesium	(Mg)	ppm	<100	<100	<100	<100
	Total Hardness	(CaCO <sub>3</sub> )	ppm - CaCO <sub>3</sub> equiv.	30 to 150	150 to 450	150 to 450	150 to 450
	Langelier Saturation Index	LSI		-0.5 to +0.5	-0.5 to +0.5	-0.5 to +0.5	-0.5 to +0.5
Ryznar Stability Index	RSI		6.5 to 8.0	6.5 to 8.0	6.5 to 8.0	6.5 to 8.0	
Corrosion Prevention	Total Dissolved Solids	(TDS)	ppm - CaCO <sub>3</sub> equiv.	<1000	<1000	<1000	<1500
	Sulfate	(SO <sub>4</sub> <sup>2-</sup> )	ppm	<200	<200	<200	<200
	Nitrate	(NO <sub>3</sub> <sup>-</sup> )	ppm	<100	<100	<100	<100
	Chlorine (free)	(Cl)	ppm	<0.5	<0.5	<0.5	<0.5
	Chloride (water < 80°F)	(Cl <sup>-</sup> )	ppm	<20	<20	<150	<150
	Chloride (water > 120°F)	(Cl <sup>-</sup> )	ppm	<20	<20	<125	<125
	Hydrogen Sulfide <sup>a</sup>	(H <sub>2</sub> S)	ppb	<0.5	<0.5	<0.5	<0.5
	Carbon Dioxide	(CO <sub>2</sub> )	ppm	0	<50	10 to 50	10 to 50
	Iron Oxide	(Fe)	ppm	<1.0	<1.0	<1.0	<0.2
	Manganese	(Mn)	ppm	< 0.4	<0.4	<0.4	<0.4
	Ammonia	(NH <sub>3</sub> )	ppm	<0.05	<0.1	<0.1	<0.1
	Chloramine	(NH <sub>2</sub> CL)	ppm	0	0	0	0
Fouling & Biological	Iron Bacteria		cells/mL	0	0	0	0
	Slime Forming Bacteria		cells/mL	0	0	0	0
	Sulfate reducing bacteria		cells/mL	0	0	0	0
	Suspended Solids <sup>b</sup>	(TSS)	ppm	<10	<10	<10	<10
Electrolysis All HX types	Earth Ground Resistance <sup>x</sup>		Ohms	0	Consult NEC & local electrical codes for grounding requirements		
	Electrolysis Voltage <sup>d</sup>		mV	<300	Measure voltage internal water loop to HP ground		
	Leakage Current <sup>d</sup>		mA	<15	Measure current in water loop pipe		
	Building Primary Electrical Ground to unit, must meet local diameter and penetration length requirements Do not connect heat pump to steel pipe unless dissimilar materials are separated by using Di-electric unions. Galvanic corrosion of heat pump water pipe will occur.						

Tranquility® Compact (TC) Series

Rev.: January 25, 2024

## Water Quality Requirements, Cont'd.

1. The ClimateMaster Water Quality Table provides water quality requirements for coaxial & brazed plate heat exchangers.
  2. The water must be evaluated by an independent testing facility comparing site samples against this Table. When water properties are outside of these parameters, the water must either be treated by a professional water treatment specialist to bring the water quality within the boundaries of this specification, or an external secondary heat exchanger must be used to isolate the heat pump water system from the unsuitable water. Failure to do so will void the warranty of the heat pump system and will limit liability for damage caused by leaks or system failure.
  3. Regular sampling, testing and treatment of the water is necessary to assure that the water quality remains within acceptable levels thereby allowing the heat pump to operate at optimum levels.
  4. If closed-loop systems are turned off for extended periods, water samples must be tested prior to operating the system.
  5. For optimal performance, it is recommended that the closed-loop piping systems are initially filled with de-ionized water.
  6. Well water with chemistry outside of these boundaries, and salt water or brackish water requires an external secondary heat exchanger. Surface/Pond water should not be used.
  7. If water temperature is expected to fall below 40°F, antifreeze is required. Refer to the heat pump IOM for the correct solution ratios to prevent freezing.
- α Hydrogen Sulfide has an odor of rotten eggs. If one detects this smell, a test for H2S must be performed. If H2S is detected above the limit indicated, remediation is necessary (Consult with your Water Testing/Treatment Professional) or a secondary heat exchanger is required using appropriate materials as recommended by the heat exchanger supplier.
  - β Suspended solids and particulates must be filtered to prevent fouling and failure of heat exchangers. Strainers or particulate filters must be installed to provide a maximum particle size of 600 micron (0.60 mm, 0.023 in.) using a 20 to 30 mesh screen size. When a loop is installed in areas with fine material such as sand or clay, further filtration is required to a maximum of 100 micron. Refer to the Strainer / Filter Sizing Chart to capture the particle sizes encountered on the site.
  - χ An electrical grounding system using a dedicated ground rod meeting NEC and Local Electrical codes must be installed. Building Ground must not be connected the WSHP piping system or other plumbing pipes.
  - δ Refer to IOM for instructions on measuring resistance and leakage currents within water loops.

**Do not use PVC pipe for water loop (compressor POE oil and glycols damage PVC) use of HDPE pipe is recommended.**

Strainer / Filter Sizing			
Mesh Size	Particle Size		
	Microns	MM	Inch
20	840	0.840	0.0340
30	533	0.533	0.0210
60	250	0.250	0.0100
100	149	0.149	0.0060
150	100	0.100	0.0040
200	74	0.074	0.0029

ppm = parts per million  
ppb = parts per billion

## Water Quality Requirements, Cont'd.

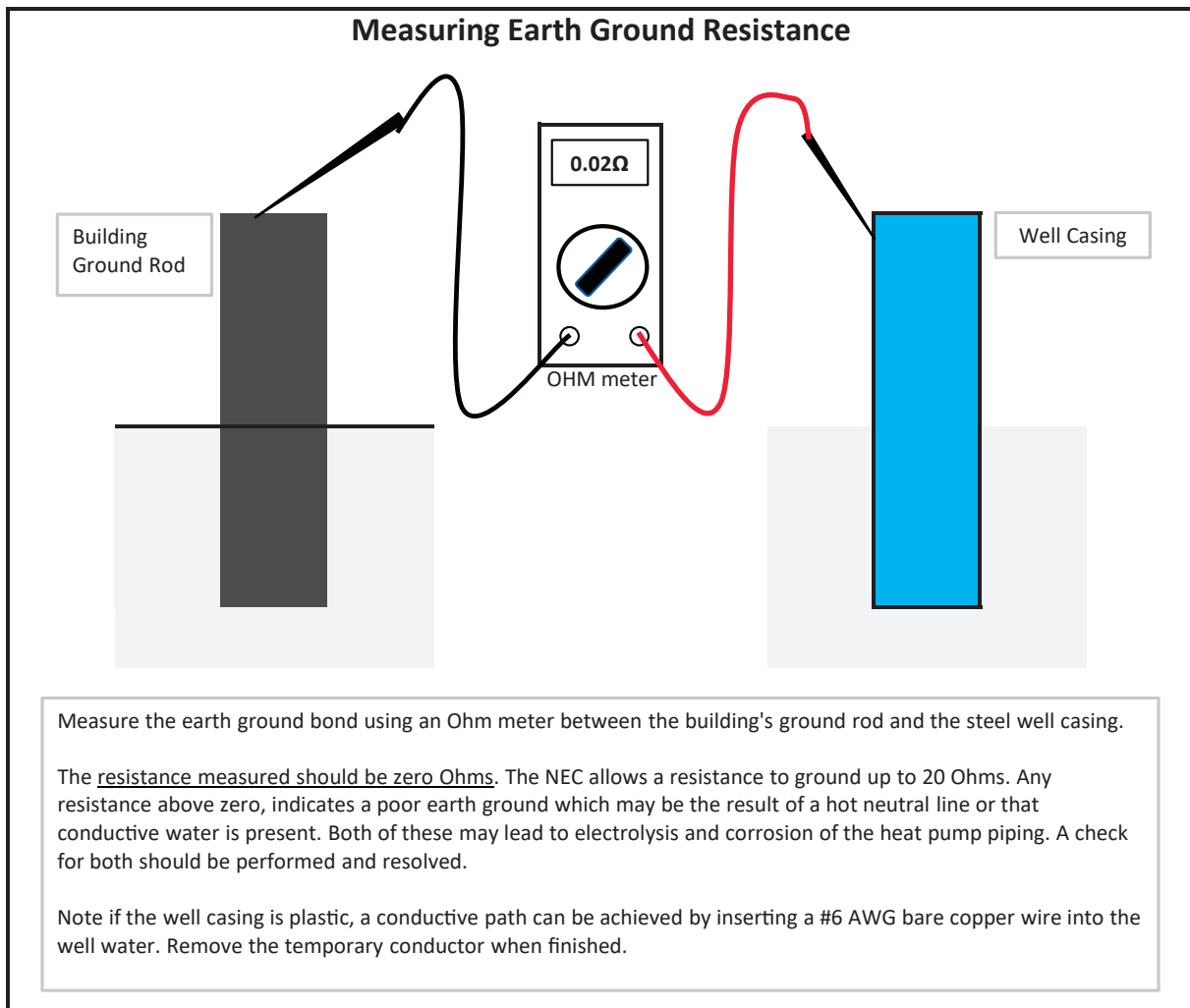

## Tranquility® Compact (TC) Series

Rev.: January 25, 2024

## Water Quality Requirements, Cont'd.

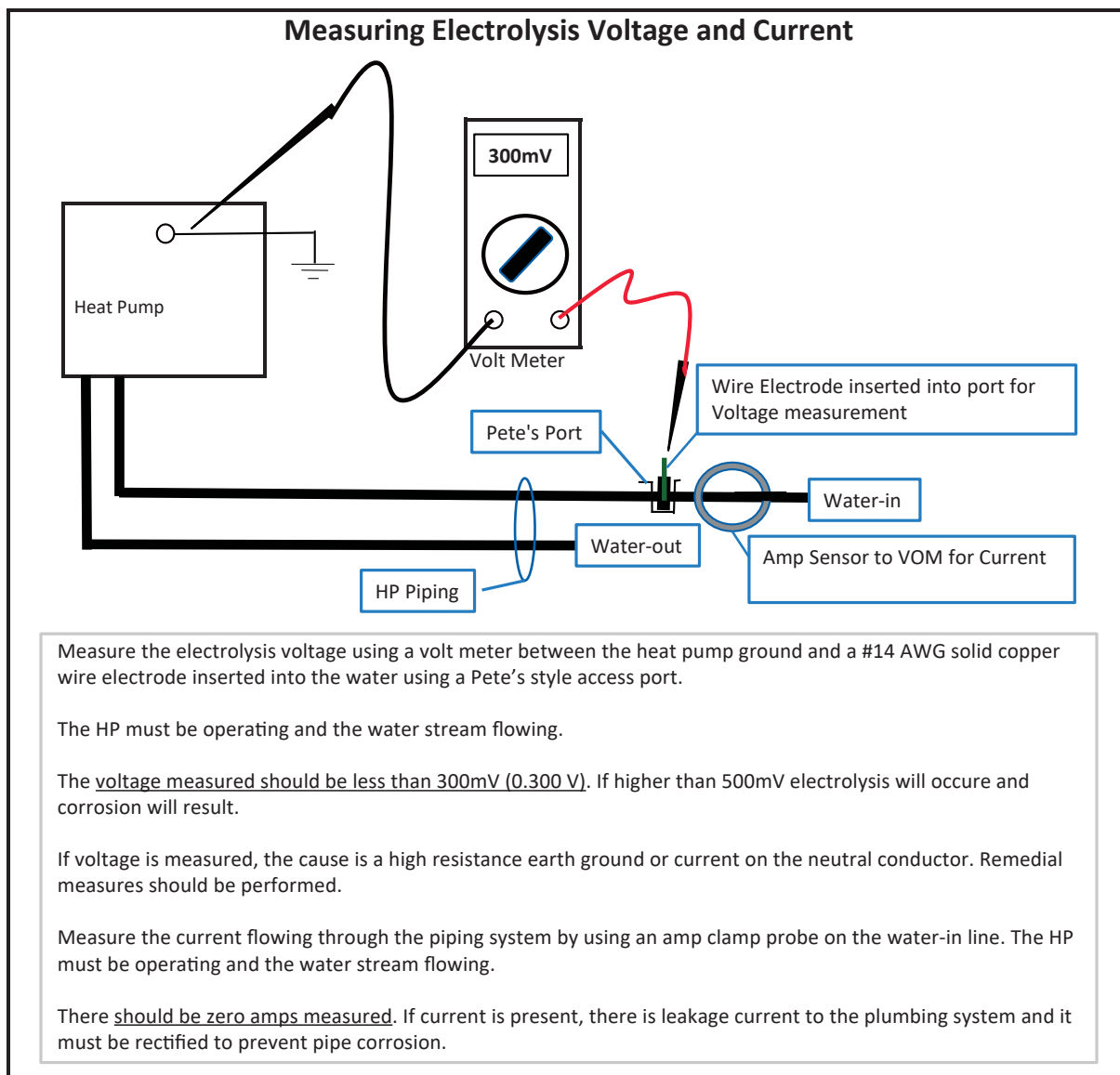

### TC: Horizontal – Dimensional Data

Horizontal Model		Overall Cabinet		
		A Width	B Length	C Height
006 - 012	in cm	19.1 48.5	34.1 86.6	11.1 28.2
015 - 018	in cm	20.1 51.1	43.1 109.5	17.0 43.2
024 - 030	in cm	20.1 51.1	43.1 109.5	18.3 46.5
036 - 042	in cm	20.1 51.1	47.1 119.6	21.0 53.3
048 - 060	in cm	24.1 61.2	54.1 137.4	21.0 53.3

Horizontal Model		Electrical Knockouts	
		J 1/2"	K 3/4"
		Low Voltage	Power Supply
006 - 012	in cm	5.1 13.0	2.1 5.4
015 - 018	in cm	9.9 25.2	6.9 17.5
024 - 030	in cm	11.1 28.2	8.1 20.6
036 - 060	in cm	13.9 35.3	10.9 27.7

Horizontal Model		Water Connections						Loop In/Out FPT
		①		②		③		
		Loop In D	Loop In E	Loop Out F	Loop Out G	AA	BB	
006 - 012	in cm	5.6 14.2	1.1 2.7	1.6 4.1	1.1 2.7	3.3 8.4	0.7 1.8	1/2"
015	in cm	15.1 38.4	1.4 3.4	3.2 8.1	1.4 3.5	3.3 8.4	0.7 1.8	1/2"
018	in cm	15.1 38.4	1.4 3.4	4.1 10.4	1.4 3.5	3.3 8.4	0.7 1.8	1/2"
024	in cm	16.4 41.7	1.4 3.4	4.4 11.3	1.4 3.5	3.3 8.4	0.7 1.8	3/4"
030	in cm	16.4 41.7	1.4 3.4	3.1 7.8	1.4 3.5	3.3 8.4	0.7 1.8	3/4"
036	in cm	19.1 48.5	1.4 3.4	5.3 13.4	1.4 3.5	3.3 8.4	0.7 1.8	3/4"
042	in cm	19.1 48.5	1.4 3.4	4.4 11.3	1.4 3.5	3.3 8.4	0.7 1.8	3/4"
048	in cm	19.1 48.5	1.4 3.4	4.4 11.1	1.4 3.5	3.3 8.4	0.7 1.8	1"
060	in cm	19.1 48.5	1.4 3.4	3.8 9.7	1.4 3.5	3.3 8.4	0.7 1.8	1"

Horizontal Model		Discharge Connection Duct Flange Installed (+/- 0.10 in, +/- 2.5mm)					Return Connection Using Return Air Opening			
		L	M Supply Height	N Supply Width	O	P	Q Return Width	R Return Height	S	T
006 - 012	in cm	0.8 1.9	8.9 22.7	6.7 17.0	6.0 15.2	1.3 3.3	16.1 41.0	9.8 25.0	1.1 2.7	0.6 1.5
015 - 018	in cm	2.6 6.6	13.3 33.8	9.9 25.1	4.1 10.5	1.3 3.3	23.0 58.4	15.0 38.1	1.1 2.8	1.0 2.5
024 - 030	in cm	2.6 6.6	13.3 33.8	9.9 25.1	4.1 10.5	1.3 3.3	23.0 58.4	16.3 41.4	1.1 2.8	1.0 2.5
036 - 042	in cm	2.5 6.3	16.1 40.9	11.0 27.9	3.0 7.7	2.5 6.4	25.9 65.8	19.0 48.3	1.1 2.8	1.0 2.5
048	in cm	3.7 9.5	16.1 41.0	13.7 34.8	4.1 10.3	1.3 3.2	35.9 91.2	19.0 48.3	1.1 2.8	1.0 2.5
060	in cm	1.7 4.4	18.1 46.0	13.7 34.8	4.1 10.3	1.3 3.2	35.9 91.2	19.0 48.3	1.1 2.8	1.0 2.5

## Tranquility® Compact (TC) Series

Rev.: January 25, 2024

### TC: Horizontal – Dimensional Data, Cont'd.

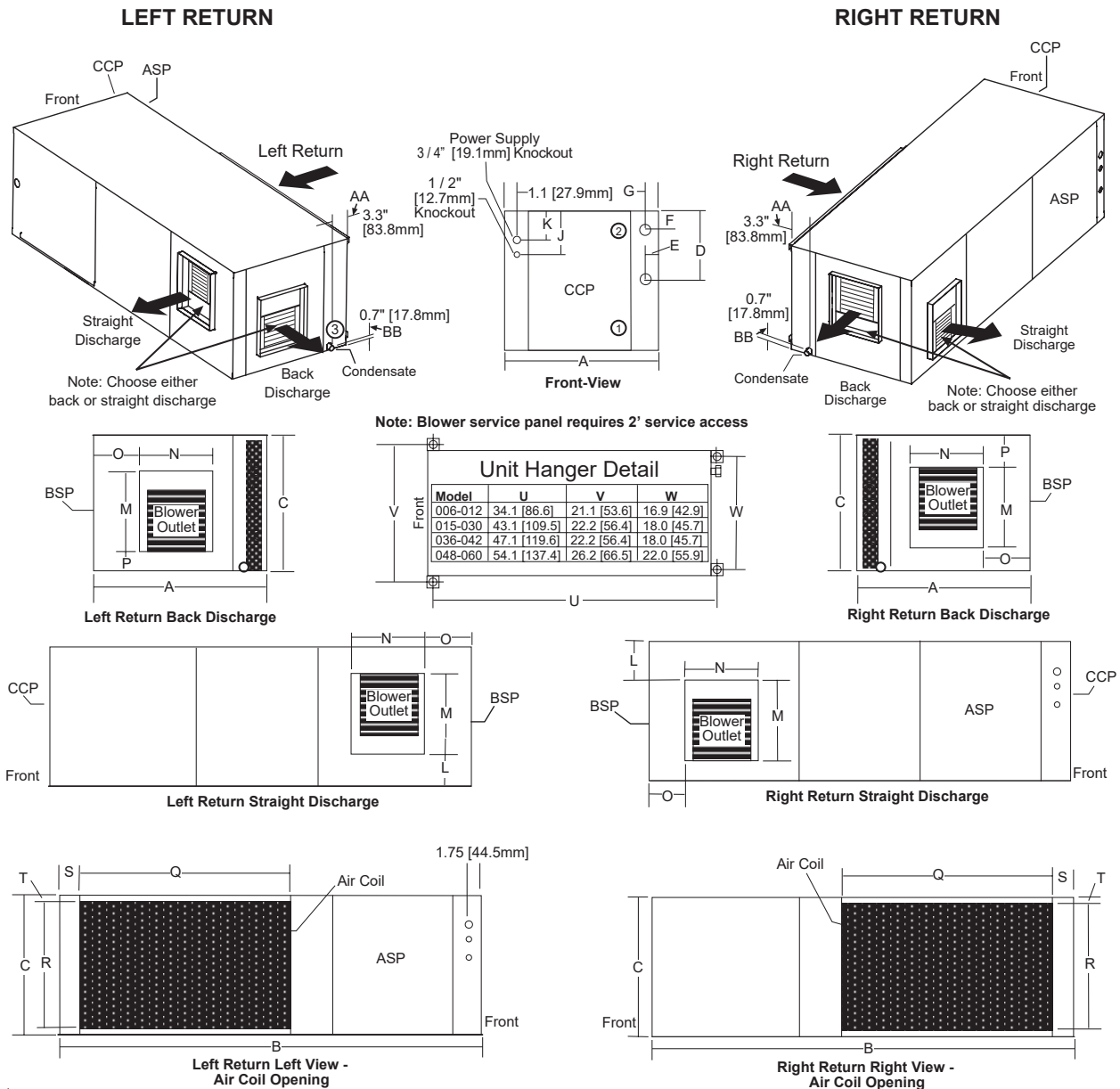

**Notes:**

1. While clear access to all removable panels is not required, installer should take care to comply with all building codes and allow adequate clearance for future field service.
2. Units are shipped with either filter rails or filter frames depending on unit model. Air filter rails are not suitable for supporting return air duct. Air filter frames are provided with a duct mounting collar for connection to return air duct.
3. Discharge flange and hanger brackets are factory installed.
4. Condensate fitting on Polymer drain pan is rubber coupling that couples to 3/4" schedule 40/80 PVC, S.S. drain pan is 3/4" MPT.
5. Blower service panel requires 2' service access.
6. Blower service access is through back panel on straight discharge units or through panel opposite air coil on back discharge units.

**Legend:**

CCP = Control/Compressor Access Panel.  
 BSP = Blower Service Panel.  
 \*ASP = Additional Service Panel (not required).

**Note:**

\*ASP are removable panels that provide additional access to the units interior. Clear access to ASP panels is not required and they are not to be used in place of the mandatory CCP and BSP panels.

TCH with Left Hand Waterside Economizer – Dimensional Data

Horizontal Model		Overall Cabinet			WSE H Width	Left WSE Connections						Return Connection Using Return Air Opening				
		A Width	B Length	C Height		In		Out		Cond. 3/4" MPT		Water In/Out FPT	Q Return Width	R Return Height	S	T
						D	E	F	G	AA	BB					
006-012	in	26.1	34.1	11.0	7.1	4.7	3.5	8.0	3.5	3.5	0.8	1/2"	16.1	10.0	1.5	0.3
	cm	66.3	86.6	27.9	18.0	11.9	8.9	20.3	8.9	8.9	2.0		40.9	25.4	3.8	0.8
015-018	in	27.2	43.1	17.0	7.1	5.3	3.5	11.5	3.5	3.5	0.8	1/2"	23.0	16.0	1.5	0.3
	cm	69.1	109.5	43.2	18.0	13.5	8.9	29.2	8.9	8.9	2.0		58.4	40.6	3.8	0.8
024-030	in	27.2	43.1	18.2	7.1	5.1	3.5	21.1	3.5	3.5	0.8	3/4"	22.9	16.0	1.5	0.3
	cm	69.1	109.5	46.2	18.0	13.0	8.9	53.6	8.9	8.9	2.0		58.2	40.6	3.8	0.8
036-042	in	27.2	47.1	21.0	7.1	6.5	3.5	14.0	3.5	3.5	0.8	3/4"	26.0	20.0	1.5	0.3
	cm	69.1	119.6	53.3	18.0	16.5	8.9	35.6	8.9	8.9	2.0		66.0	50.8	3.8	0.8
048-060	in	31.6	54.1	21.0	7.5	5.0	1.3	15.9	1.3	3.5	0.8	3/4"	36.0	20.0	1.5	0.3
	cm	80.3	137.4	53.3	19.1	12.7	3.3	40.4	3.3	8.9	2.0		91.4	50.8	3.8	0.8

Left Return with WSE

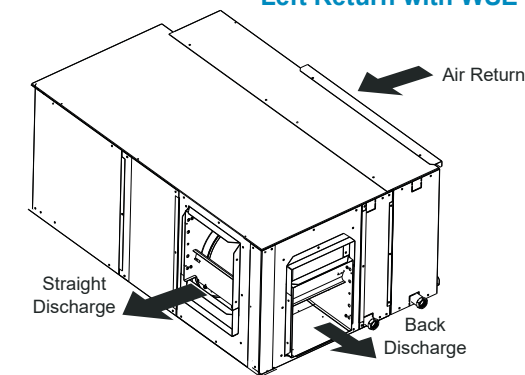

Unit Hanger Detail

Model	U	V	W
006-012	34.1 [86.6]	21.1 [53.6]	16.9 [42.9]
015-030	43.1 [109.5]	22.2 [56.4]	18.0 [45.7]
036-042	47.1 [119.6]	22.2 [56.4]	18.0 [45.7]
048-060	54.1 [137.4]	26.2 [66.5]	22.0 [55.9]

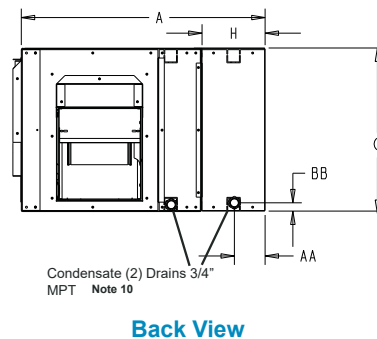
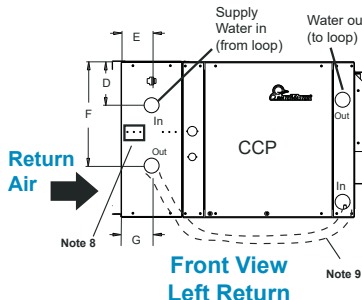
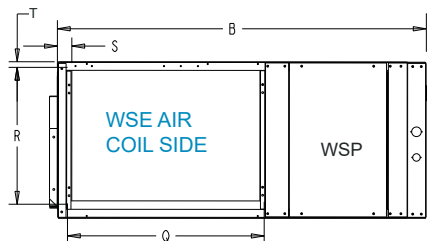

Notes:

- While clear access to all removable panels is not required, installer should take care to comply with all building codes and allow adequate clearance for future field service.
- Units are shipped with either filter rails or filter frames depending on unit model. Air filter rails are not suitable for supporting return air duct. Air filter frames are provided with a duct mounting collar for connection to return air duct.
- Discharge flange and hanger brackets are factory installed.
- Condensate drains are 3/4" MPT.
- Blower service panel requires 2' service access.
- Blower service access is through back panel on straight discharge units or through panel opposite air coil on back discharge units.
- Filters same size as standard unit.
- Factory supplied controller (aquastat) is shipped inside unit. Open waterside economizer panel (WSP), remove, slide onto dinrail, and connect molex.
- WSE to unit piping to be field fabricated, Run below or in front. Must leave room to remove front access panel (CCP) to service unit.
- External trap and vent both drains before joining.
- Refer to Discharge Air connection dimensions.

Tranquility® Compact (TC) Series

Rev.: January 25, 2024

TCH with Right Hand Waterside Economizer – Dimensional Data

Horizontal Model		Overall Cabinet			WSE	Left WSE Connections							Return Connection Using Return Air Opening				
		A Width	B Length	C Height		H Width	In		Out		Cond. 3/4" MPT		Water In/Out FPT	Q Return Width	R Return Height	S	T
							D	E	F	G	AA	BB					
006-012	in	26.1	34.1	11.0	7.1	8.0	3.5	4.7	3.5	3.5	0.8	1/2"	16.1	10.0	1.5	0.3	
	cm	66.3	86.6	27.9	18.0	20.3	8.9	11.9	8.9	8.9	2.0		40.9	25.4	3.8	0.8	
015-018	in	27.2	43.1	17.0	7.1	11.5	3.5	5.3	3.5	3.5	0.8	1/2"	23.0	16.0	1.5	0.3	
	cm	69.1	109.5	43.2	18.0	29.2	8.9	13.5	8.9	8.9	2.0		58.4	40.6	3.8	0.8	
024-030	in	27.2	43.1	18.2	7.1	21.1	3.5	5.1	3.5	3.5	0.8	3/4"	22.9	16.0	1.5	0.3	
	cm	69.1	109.5	46.2	18.0	53.6	8.9	13.0	8.9	8.9	2.0		58.2	40.6	3.8	0.8	
036-042	in	27.2	47.1	21.0	7.1	14.0	3.5	6.5	3.5	3.5	0.8	3/4"	26.0	20.0	1.5	0.3	
	cm	69.1	119.6	53.3	18.0	35.6	8.9	16.5	8.9	8.9	2.0		66.0	50.8	3.8	0.8	
048-060	in	31.6	54.1	21.0	7.5	15.9	1.3	5.0	1.3	3.5	0.8	3/4"	36.0	20.0	1.5	0.3	
	cm	80.3	137.4	53.3	19.1	40.4	3.3	12.7	3.3	8.9	2.0		91.4	50.8	3.8	0.8	

**Unit Hanger Detail**

Model	U	V	W
006-012	34.1 [86.6]	21.1 [53.6]	16.9 [42.9]
015-030	43.1 [109.5]	22.2 [56.4]	18.0 [45.7]
036-042	47.1 [119.6]	22.2 [56.4]	18.0 [45.7]
048-060	54.1 [137.4]	26.2 [66.5]	22.0 [55.9]

Right Return with WSE

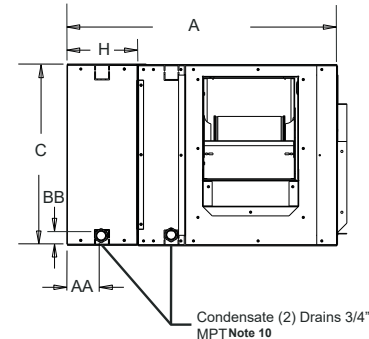
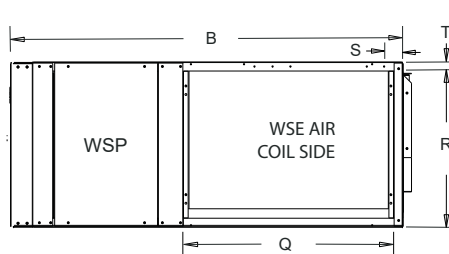
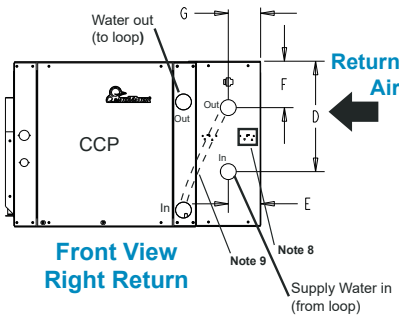
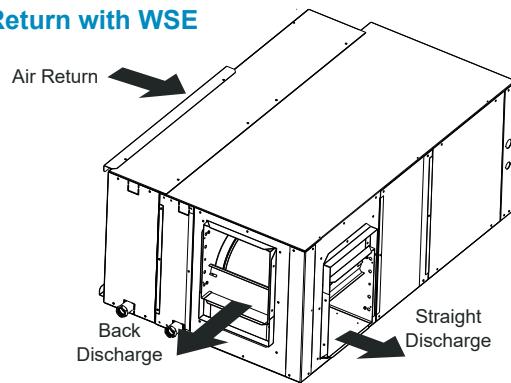

Notes:

1. While clear access to all removable panels is not required, installer should take care to comply with all building codes and allow adequate clearance for future field service.
2. Units are shipped with either filter rails or filter frames depending on unit model. Air filter rails are not suitable for supporting return air duct. Air filter frames are provided with a duct mounting collar for connection to return air duct.
3. Discharge flange and hanger brackets are factory installed.
4. Condensate drains are 3/4" MPT.
5. Blower service panel requires 2' service access.
6. Blower service access is through back panel on straight discharge units or through panel opposite air coil on back discharge units.
7. Filters same size as standard unit.
8. Factory supplied controller (aquastat) is shipped inside unit. Open waterside economizer panel (WSP), remove, slide onto dinrail, and connect moxex.
9. WSE to unit piping to be field fabricated. Run below or in front. Must leave room to remove front access panel (CCP) to service unit.
10. External trap and vent both drains before joining.
11. Refer to Discharge Air connection dimensions.

## TC: Horizontal Service Access

Left Return Back Discharge

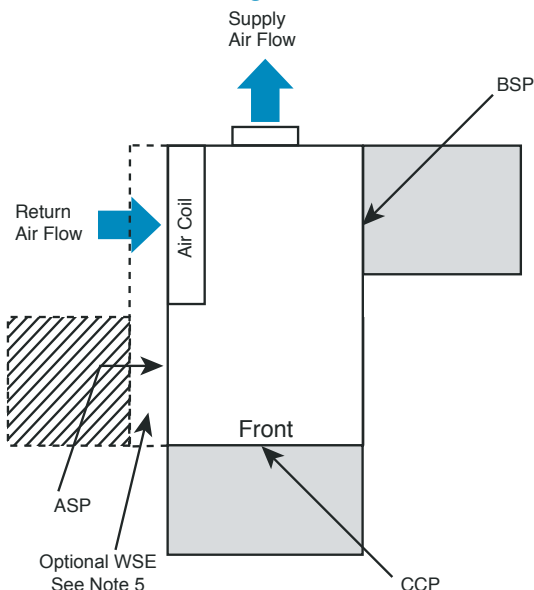

Right Return Back Discharge

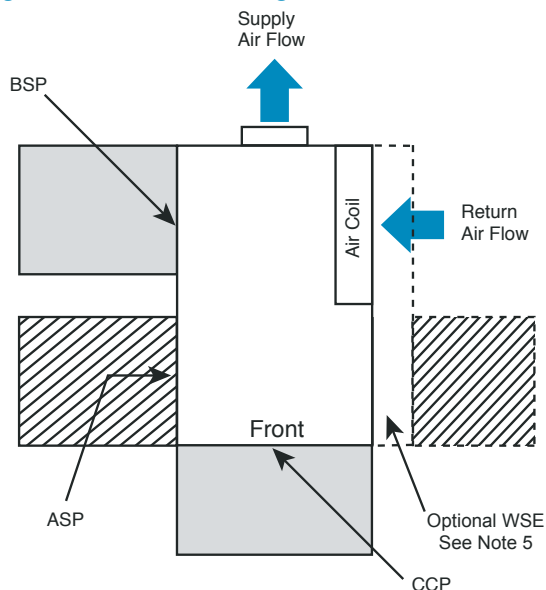

Left Return Straight Discharge

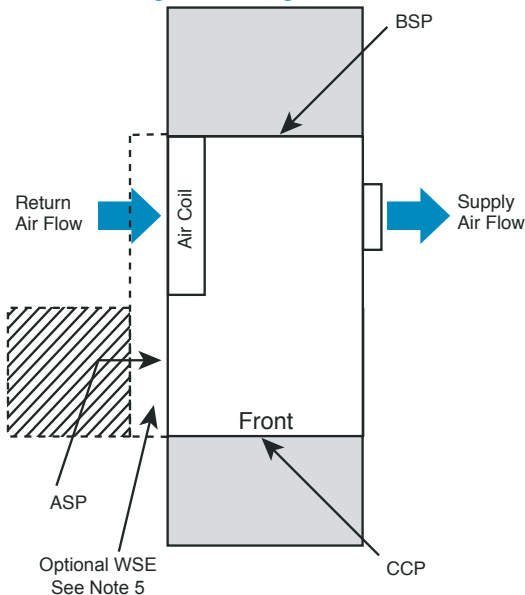

Right Return Straight Discharge

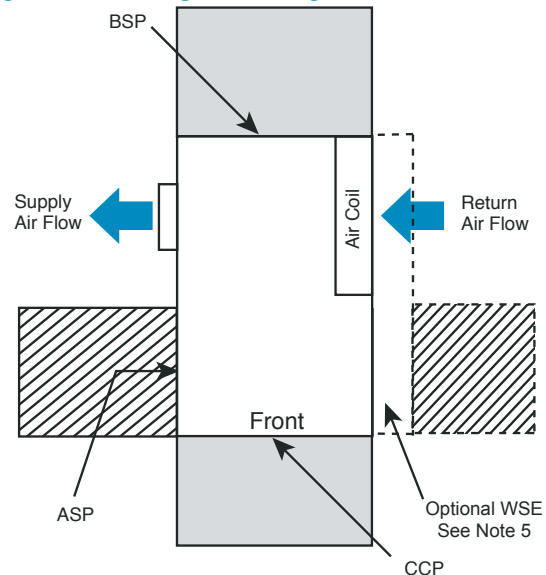

Notes:

1. While clear access to all removable panels is not required, installer should take care to comply with all building codes and allow adequate clearance for future field service.
2. CCP and BSP requires 2' service access.
3. Blower service access is through back panel on straight discharge units or through panel opposite air coil on back discharge units.
4. ASP are removable panels that provide additional access to the units interior. Clear access to ASP panels is not required and they are not to be used in place of the mandatory CCP and BSP panels.
5. Units with WSE must have access to water valve through side access panel.

- = mandatory 2' service access
- = (optional) additional 2' service access

Legend:

- CCP = Control/Compressor Access Panel
- BSP = Blower Service Panel
- ASP = Additional Service Panel (not required)
- WSE = Waterside Economizer

## Tranquility® Compact (TC) Series

Rev.: January 25, 2024

### TC: Vertical Upflow – Dimensional Data

Vertical Upflow Model		Overall Cabinet		
		A Width	B Depth	C Height
006 - 012	in	19.1	19.1	22.0
	cm	48.5	48.5	55.9
015 - 030, 041	in	21.5	21.5	40.0
	cm	54.6	54.6	101.6
036 - 042	in	21.5	26.0	45.0
	cm	54.6	66.0	114.3
048 - 060	in	24.0	32.5	46.0
	cm	61.0	82.6	116.8

Vertical Model		Electrical Knockouts	
		J 1/2"	K 3/4"
		Low Voltage	Power Supply
006 - 012	in	5.9	8.9
	cm	14.9	22.5
015 - 060	in	7.1	10.1
	cm	18.1	25.7
041	in	7.1	11.1
	cm	18.0	28.2

Vertical Upflow Model		Water Connections - Standard Units						
		①		②		③		Loop In/Out FPT
		Loop In D	Loop In E	Loop Out F	Loop Out G	H	I	
006 - 012	in	1.5	1.5	9.5	1.5	11.7	1.4	1/2"
	cm	3.8	3.8	24.1	3.8	29.7	3.6	
015	in	1.9	1.4	13.8	1.4	19.7	1.4	1/2"
	cm	4.8	3.6	35.1	3.6	50.0	3.6	
018	in	1.9	1.4	13.8	1.4	19.7	1.4	1/2"
	cm	4.8	3.6	35.1	3.6	50.0	3.6	
024	in	1.9	1.4	13.8	1.4	19.7	1.4	3/4"
	cm	4.8	3.6	35.1	3.6	50.0	3.6	
030	in	1.9	1.4	15.2	1.4	19.7	1.4	3/4"
	cm	4.8	3.6	38.6	3.6	50.0	3.6	
036	in	1.9	1.4	15.2	1.4	20.6	1.4	3/4"
	cm	4.8	3.6	38.6	3.6	52.3	3.6	
041	in	3.6	2.3	14.0	2.3	18.3	2.3	3/4"
	cm	4.8	5.8	35.6	5.8	46.5	5.8	
042	in	1.9	1.4	16.6	1.4	20.6	1.4	3/4"
	cm	4.8	3.6	42.0	3.6	52.3	3.6	
048	in	2.0	1.4	16.9	1.4	21.6	1.4	1"
	cm	5.1	3.6	42.9	3.6	54.9	3.6	
060	in	2.0	1.4	17.4	1.4	21.6	1.4	1"
	cm	5.1	3.6	44.2	3.6	54.9	3.6	

**Notes:**

- While clear access to all removable panels is not required, installer should take care to comply with all building codes and allow adequate clearance for future field service.
- Front & Side access is preferred for service access. However, all components may be serviced from the front access panel if side access is not available. (Except on TCV 009-030 and 041 with front return) Units with the front return require left side access for the fan.
- Discharge flange is field installed.
- Condensate fitting on Polymer drain pan is rubber coupling that couples to 3/4" schedule 40/80 PVC, S.S. drain pan is 3/4" MPT.
- Units are shipped with air filter rails that are not suitable for supporting return air ductwork. An air filter frame with duct mounting collar is available as an accessory, see the ClimateMaster Accessory Submittal set for further information on this frame.

**Legend:**

- CCP = Control/Compressor Access Panel
- BSP = Blower Service Panel
- ASP = Alternative Service Panel

Recommended Minimum Installation Clearances for Vertical Units*	
1"	Back of unit
	Side opposite return air
6"	Front if hard piped
Return Air Side	
1"	Ducted return
	- ± *Add for duct width
	- † Add 2" for 1" filter frame/rail or 3" for 2" filter frame/rail
	Free (open) return - calculate required dimension for a maximum velocity of 600 fpm

\* Field installed accessories (hoses, air cleaners, etc.) and factory WSE option will require additional space. Top supply air is shown, the same clearances apply to bottom supply air units.

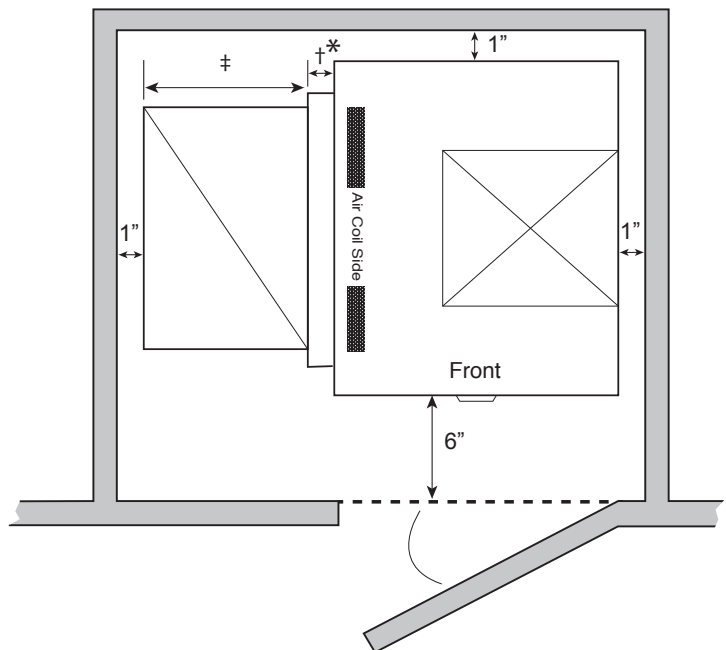

TCV: Vertical Upflow – Dimensional Data, Cont'd.

Vertical Model		Discharge Connection Duct Flange Installed (+/- 0.10 in, +/- 2.5mm)					Return Connection Using Return Air Opening			
		M	N	O Supply Width	P Supply Depth	Q	R	S Return Depth	T Return Height	U
006 - 012	in	8.9	5.1	9.0	9.0	5.5	2.1	16.2	9.9	0.7
	cm	22.7	12.9	22.9	22.9	14.0	5.3	41.1	25.1	1.9
015 - 018	in	6.4	3.8	14.0	14.0	5.3	2.3	18.3	20.9	0.7
	cm	16.1	9.5	35.6	35.6	13.6	5.8	46.5	53.1	1.9
024 - 030	in	6.4	5.0	14.0	14.0	5.8	2.0	18.5	19.3	0.9
	cm	16.3	12.7	35.6	35.6	14.7	5.1	47.0	49.0	2.3
036 - 042	in	6.4	3.8	14.0	14.0	5.1	2.3	22.8	23.9	0.7
	cm	16.1	9.5	35.6	35.6	13.1	5.8	57.9	60.7	1.9
048 - 060	in	6.9	7.3	16.0	18.0	5.1	2.3	29.3	22.5	0.7
	cm	17.4	18.4	40.6	45.7	13.1	5.8	74.4	57.0	1.9

Front Return - N = 4.8 in (12.2 cm), Q = 6.4 in (16.3 cm).  
 Right Return - N = 3.8 in (9.7 cm), Q = 5.5 in (14.0 cm).  
 Left Return - M = 6.4 in (16.3 cm), N = 2.8 in (7.1 cm).

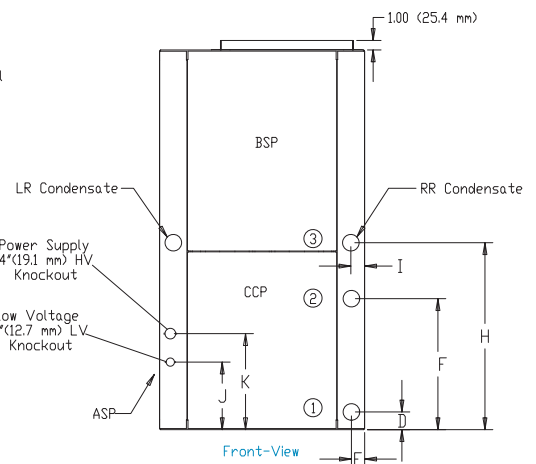
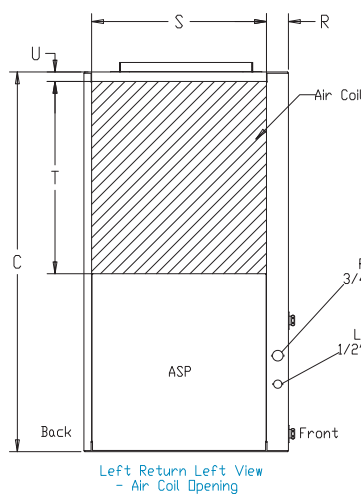
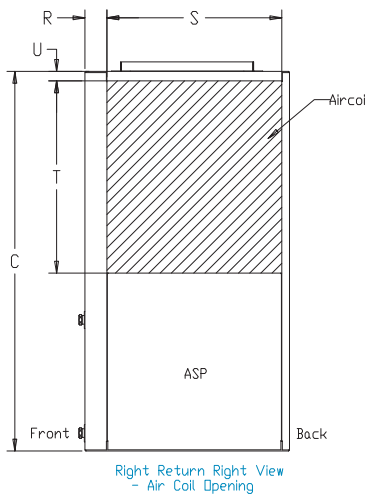
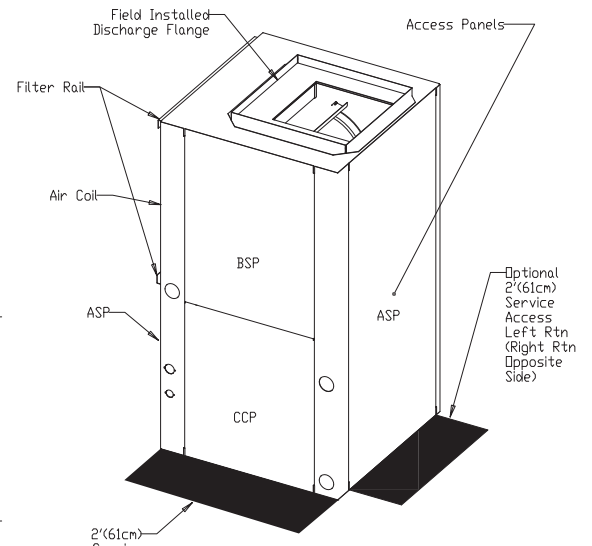
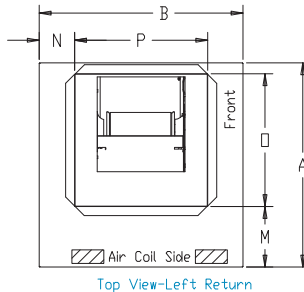
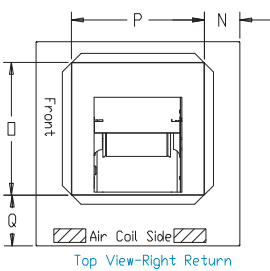
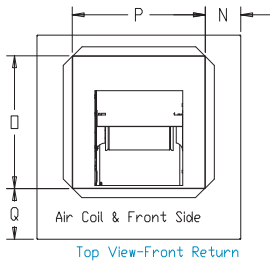

Units are shipped with either filter rails or filter frames depending on unit model. Air filter rails are not suitable for supporting return air duct. Air filter frames are provided with a duct mounting collar for connection to return air duct.

Tranquility® Compact (TC) Series

Rev.: January 25, 2024

TC: Front Return Vertical Upflow – Dimensional Data

Vertical Model		Overall Cabinet			Water Connection - Front Return Units			Top Discharge Connection Duct Flange Installed (+/- 0.10 in, +/- 2.5mm)			
		A Width	B Depth	C Height	D Water In	F Water Out	H Cond. Drain	N	O Supply Width	P Supply Depth	Q
009 - 012	in	19.1	19.0	22.0	1.6	9.6	11.5	5.1	9.0	9.0	6.0
	cm	48.5	48.3	55.9	4.1	24.4	29.2	12.9	22.9	22.9	15.2
015 - 018	in	21.6	21.5	40.0	1.9	13.8	19.7	3.8	14.0	14.0	5.4
	cm	54.9	54.6	101.6	4.8	35.1	50.0	9.5	35.6	35.6	13.7
024	in	21.6	21.5	40.0	1.9	13.8	19.7	3.8	14.0	14.0	5.4
	cm	54.9	54.6	101.6	4.8	35.1	50.0	12.7	35.6	35.6	14.7
030	in	21.6	21.5	40.0	1.9	15.2	19.7	3.8	14.0	14.0	5.4
	cm	54.9	54.6	101.6	4.8	38.6	50.0	12.7	35.6	35.6	14.7
041	in	21.6	21.6	39.0	3.6	14.0	18.3	4.8	14.0	14.0	6.4
	cm	54.9	54.9	99.1	9.1	35.6	46.5	9.5	35.6	35.6	13.0

\* For Air Coil and Filter Dimensions see the physical data table.  
See electrical knockout table for details on low and high voltage power connection dimensions.

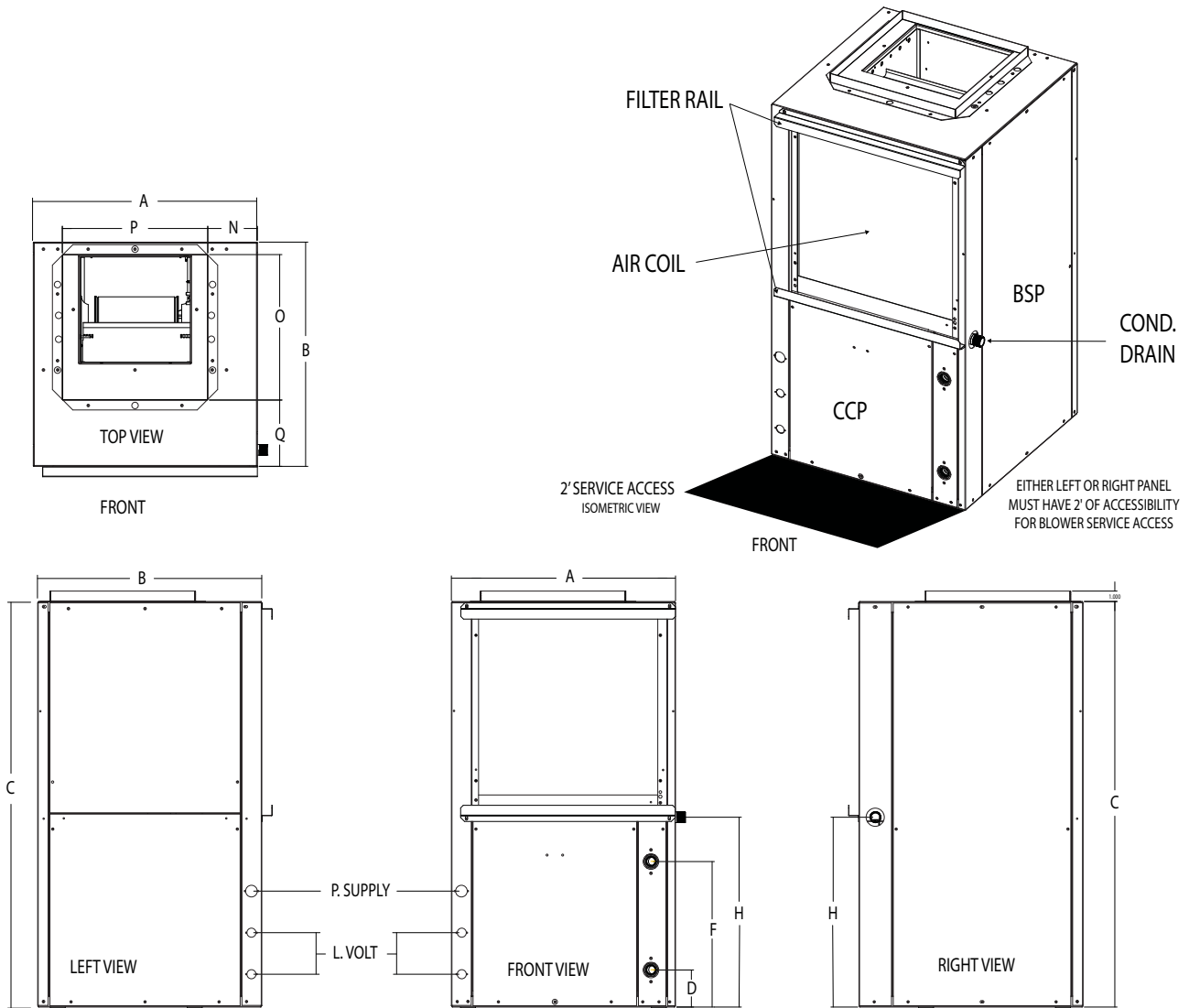

Units are shipped with either filter rails or filter frames depending on unit model. Air filter rails are not suitable for supporting return air duct. Air filter frames are provided with a duct mounting collar for connection to return air duct.

## TCV with Left Hand Waterside Economizer – Dimensional Data

Vertical Model		Overall Cabinet			WSE	WSE Connections						Return Connection Using Return Air Opening					
		A Width	B Length	C Height		H Width	In		Out		Cond. 3/4" MPT		Water In/Out FPT	Q Return Width	R Return Height	S	T
							D	E	F	G	AA	BB					
006-012	in	26.1	21.2	22.0	7.1	8.1	5.5	2.1	5.5	5.1	5.5	1/2"	16.1	10.0	4.2	0.4	
	cm	66.3	53.8	55.9	18.0	20.6	14.0	5.3	14.0	13.0	14.0		40.9	25.4	10.7	1.0	
015-030	in	29.0	24.7	40.0	7.4	11.6	6.0	2.6	6.0	7.1	6.0	3/4"	18.1	20.0	3.8	0.3	
	cm	73.7	62.7	101.6	18.8	29.5	15.2	6.6	15.2	18.0	15.2		46.0	50.8	9.7	0.8	
036-042	in	29.0	28.7	45.0	7.4	12.1	6.0	2.6	6.0	7.1	6.0	3/4"	22.7	24.0	4.6	0.1	
	cm	73.7	72.9	114.3	18.8	29.5	15.2	6.6	15.2	18.0	15.2		57.7	61.0	11.7	0.3	
048-060	in	31.2	37.2	46.0	7.0	12.1	5.8	3.1	5.8	7.1	5.8	3/4"	29.3	24.0	5.0	0.1	
	cm	79.2	94.5	116.8	17.8	30.7	14.7	7.9	14.7	18.0	14.7		74.4	61.0	12.7	0.3	

### Left Return with WSE

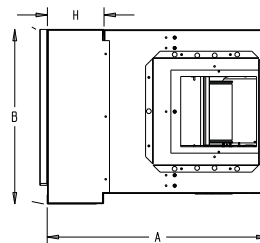
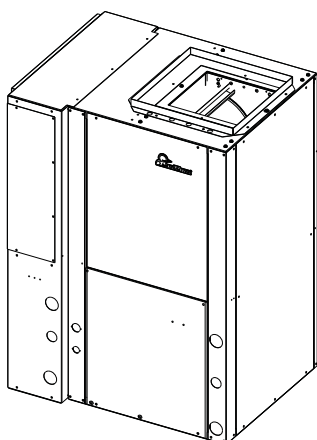

Top View

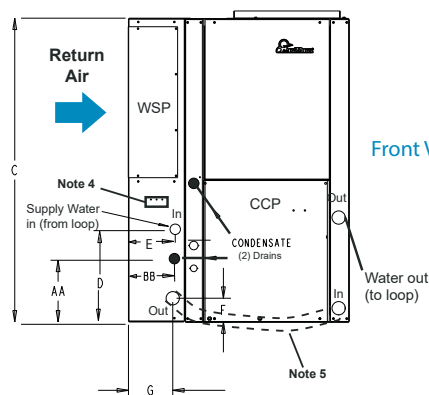
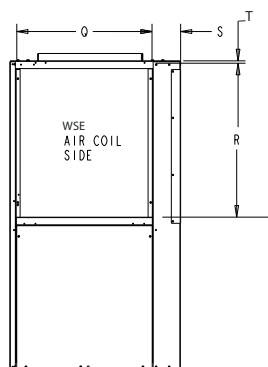

Front View Left Return

### Notes:

- Units are shipped with either filter rails or filter frames depending on unit model. Air filter rails are not suitable for supporting return air duct. Air filter frames are provided with a duct mounting collar for connection to return air duct.
- WSE condensate drain is 3/4" FPT, Unit condensate drain is 3/4" MPT. Externally trap and vent both drains before joining.
- Filters same size as standard unit.
- Factory supplied controller (aquastat) is shipped inside unit. Open waterside economizer panel (WSP), remove, slide onto dinrail, and connect molex.
- WSE to unit piping to be field fabricated, run below or in front. Must leave room to remove front access panel (CCP) to service unit.
- Refer to Discharge Air connection dimensions.

Tranquility® Compact (TC) Series

Rev.: January 25, 2024

TCV with Right Hand Waterside Economizer – Dimensional Data

Vertical Model	Overall Cabinet			WSE	WSE Connections							Return Connection Using Return Air Opening				
	A Width	B Length	C Height		H Width	In		Out		Cond. 3/4" MPT		Water In/Out FPT	Q Return Width	R Return Height	S	T
						D	E	F	G	AA	BB					
006-012	in	26.1	21.2	22.0	7.1	2.1	5.5	8.1	5.5	5.1	5.5	1/2"	16.1	10.0	4.2	0.4
	cm	66.3	53.8	55.9	18.0	5.3	14.0	20.6	14.0	13.0	14.0		40.9	25.4	10.7	1.0
015-030	in	29.0	24.7	40.0	7.4	2.6	6.0	11.6	6.0	7.1	6.0	3/4"	18.1	20.0	3.8	0.3
	cm	73.7	62.7	101.6	18.8	6.6	15.2	29.5	15.2	18.0	15.2		46.0	50.8	9.7	0.8
036-042	in	29.0	28.7	45.0	7.4	2.6	6.0	12.1	6.0	7.1	6.0	3/4"	22.7	24.0	4.6	0.1
	cm	73.7	72.9	114.3	18.8	6.6	15.2	29.5	15.2	18.0	15.2		57.7	61.0	11.7	0.3
048-060	in	31.2	37.2	46.0	7.0	3.1	5.8	12.1	5.8	7.1	5.8	3/4"	29.3	24.0	5.0	0.1
	cm	79.2	94.5	116.8	17.8	7.9	14.7	30.7	14.7	18.0	14.7		74.4	61.0	12.7	0.3

Right Return with WSE

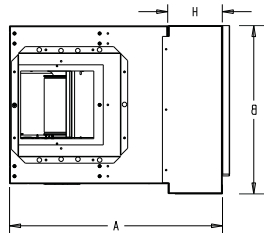

Top View

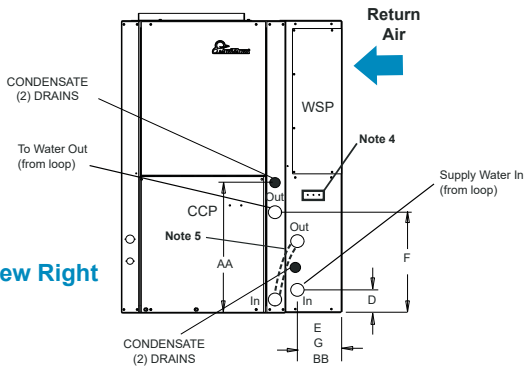
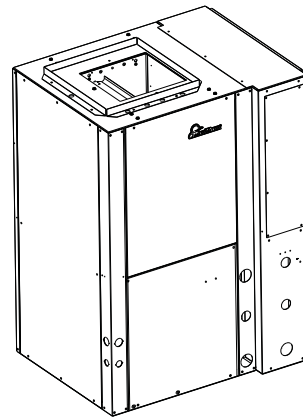

Front View Right Return

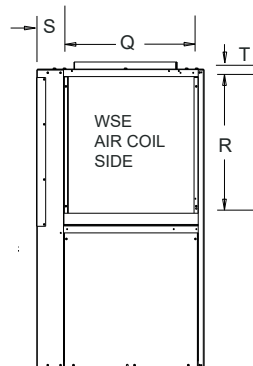

Notes:

- Units are shipped with either filter rails or filter frames depending on unit model. Air filter rails are not suitable for supporting return air duct. Air filter frames are provided with a duct mounting collar for connection to return air duct.
- WSE condensate drain is 3/4" FPT. Unit condensate drain is 3/4" MPT. Externally trap and vent both drains before joining.
- Filters same size as standard unit.
- Factory supplied controller (aquastat) is shipped inside unit. Open waterside economizer panel (WSP), remove, slide onto dinrail, and connect molex.
- WSE to unit piping to be field fabricated below or in front. Must leave room to remove front access panel(CCP) to service unit.
- Refer to Discharge Air connection dimensions.

## TC: Vertical Service Access

### Vertical Units

Left Return

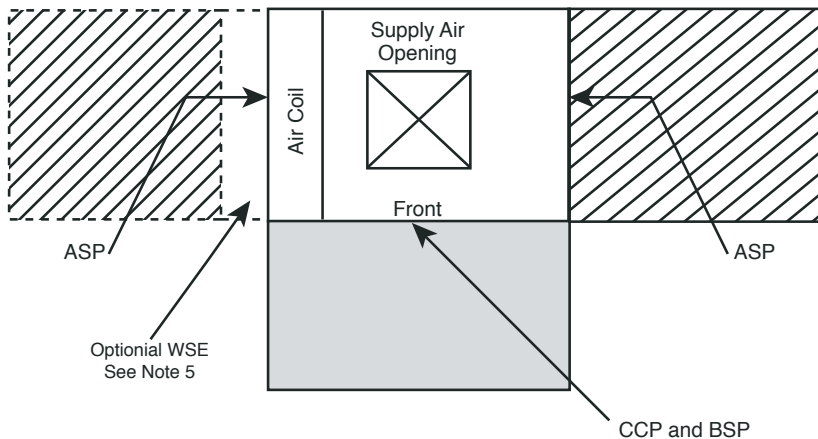

Right Return

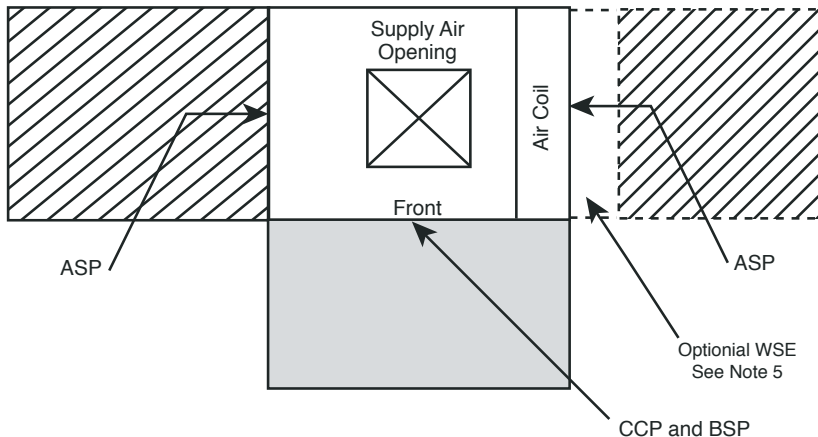

Notes:

1. While clear access to all removable panels is not required, installer should take care to comply with all building codes and allow adequate clearance for future field service.
2. Front & Side access is preferred for service access. However, units without WSE option may be serviced from the front access panel if side access is not available.
3. ASP are removable panels that provide additional access to the units interior. Clear access to ASP panels is not required and they are not to be used in place of the mandatory CCP and BSP panels.
4. Front return units (not shown) require front access for controls/compressor and left side access for blower.
5. Units with WSE Must have access to water valve through side access panel.

- = mandatory 2' service access
- = (optional) additional 2' service access

Legend:  
 CCP = Control/Compressor Access Panel  
 BSP = Blower Service Panel  
 ASP = Additional Service Panel (not required)  
 WSE = Waterside Economizer

Tranquility® Compact (TC) Series

Rev.: January 25, 2024

Electrical Data: Standard Unit

Table 4: Electrical Data - Standard Units

MODEL	VOLTAGE CODE	RATED VOLTAGE	VOLTAGE MIN/MAX	COMPRESSOR			FAN MOTOR FLA	TOTAL UNIT FLA	MIN CIRCUIT AMP	MAX FUSE/HACR	SCCR kA rms symmetrical	SCCR Volts Maximum
				QTY	RLA	LRA						
006	G	208-230 / 60 / 1	187.2 / 253	1	2.6	17.7	0.3	2.9	3.6	15	5	600
	E	265 / 60 / 1	238.5 / 291.5	1	2.6	13.5	0.4	3.0	3.6	15	5	600
009	G	208-230 / 60 / 1	187.2 / 253	1	3.7	22	0.8	4.5	5.5	15	5	600
	E	265 / 60 / 1	238.5 / 291.5	1	3.4	17.5	0.8	4.2	5.1	15	5	600
012	G	208-230 / 60 / 1	187.2 / 253	1	5.6	32.5	0.8	6.4	7.8	15	5	600
	E	265 / 60 / 1	238.5 / 291.5	1	4.2	31.5	0.8	5.0	6.1	15	5	600
015	G	208-230 / 60 / 1	187.2 / 253	1	5.6	29.0	0.9	6.5	7.9	15	5	600
	E	265 / 60 / 1	238.5 / 291.5	1	5.0	28.0	0.7	5.7	7.0	15	5	600
018	G	208-230 / 60 / 1	187.2 / 253	1	7.4	33.0	0.9	8.3	10.2	15	5	600
	E	265 / 60 / 1	238.5 / 291.5	1	6.0	28.0	0.7	6.7	8.2	15	5	600
024	G	208-230 / 60 / 1	187.2 / 253	1	12.8	58.3	1.5	14.3	17.5	30	5	600
	E	265 / 60 / 1	238.5 / 291.5	1	9.6	54.0	1.2	10.8	13.2	20	5	600
	F	460 / 60 / 3	414 / 506	1	3.6	28.0	1.4	5.0	5.9	15	5	600
	H	208-230 / 60 / 3	187.2 / 253	1	7.7	55.4	1.5	9.2	11.1	15	5	600
030	G	208-230 / 60 / 1	187.2 / 253	1	14.1	73.0	2.7	16.8	20.3	30	5	600
	E	265 / 60 / 1	238.5 / 291.5	1	11.2	60.0	2.9	14.1	16.9	25	5	600
	F	460 / 60 / 3	414 / 506	1	4.2	28.0	1.6	5.8	6.9	15	5	600
	H	208-230 / 60 / 3	187.2 / 253	1	8.9	58.0	2.7	11.6	13.8	20	5	600
036	G	208-230 / 60 / 1	187.2 / 253	1	16.7	79.0	2.7	19.4	23.5	40	5	600
	E	265 / 60 / 1	238.5 / 291.5	1	13.5	72.0	2.0	15.5	18.9	30	5	600
	F	460 / 60 / 3	414 / 506	1	5.8	38.0	1.2	7.0	8.5	15	5	600
	H	208-230 / 60 / 3	187.2 / 253	1	10.4	73.0	2.7	13.1	15.7	25	5	600
041*	G	208-230 / 60 / 1	187.2 / 253	1	17.9	112.0	2.7	20.6	25.1	40	5	600
	F	460 / 60 / 3	414 / 506	1	6.0	44.0	1.6	7.6	9.1	15	5	600
	H	208-230 / 60 / 3	187.2 / 253	1	13.2	88.0	2.7	15.9	19.2	30	5	600
	N	575 / 60 / 3	517.5 / 632.5	1	4.2	30.0	1.4	5.6	6.7	15	5	600
042	G	208-230 / 60 / 1	187.2 / 253	1	17.9	112.0	2.7	20.6	25.1	40	5	600
	F	460 / 60 / 3	414 / 506	1	6.0	44.0	1.6	7.6	9.1	15	5	600
	H	208-230 / 60 / 3	187.2 / 253	1	13.5	88.0	2.7	16.2	19.6	30	5	600
	N	575 / 60 / 3	517.5 / 632.5	1	4.9	34.0	1.4	6.3	7.5	15	5	600
048	G	208-230 / 60 / 1	187.2 / 253	1	21.8	117.0	3.3	25.1	30.6	50	5	600
	F	460 / 60 / 3	414 / 506	1	6.2	41.0	1.7	7.9	9.5	15	5	600
	H	208-230 / 60 / 3	187.2 / 253	1	13.7	83.1	3.3	17.0	20.4	30	5	600
	N	575 / 60 / 3	517.5 / 632.5	1	4.8	33.0	1.4	6.2	7.4	15	5	600
060	G	208-230 / 60 / 1	187.2 / 253	1	26.3	134.0	4.8	31.1	37.7	60	5	600
	F	460 / 60 / 3	414 / 506	1	7.8	52.0	2.4	10.2	12.2	15	5	600
	H	208-230 / 60 / 3	187.2 / 253	1	15.6	110.0	4.8	20.4	24.3	40	5	600
	N	575 / 60 / 3	517.5 / 632.5	1	5.8	38.9	1.8	7.6	9.1	15	5	600

\* 460 volt units require a neutral connection.  
 All "F" voltage units with Constant Volume (CV) ECM require a four wire power supply with neutral.  
 Motors are 265 volt and are wired between one hot leg and neutral.  
 All fuses Class RK-5

Electrical Data: High Static Blower

MODEL	VOLTAGE CODE	RATED VOLTAGE	VOLTAGE MIN/ MAX	COMPRESSOR			FAN MOTOR FLA	TOTAL UNIT FLA	MIN CIRCUIT AMP	MAX FUSE/ HACR	SCCR kA rms symmetrical	SCCR Volts Maximum
				QTY	RLA	LRA						
015	G	208-230 / 60 / 1	187.2 / 253	1	5.6	29.0	0.9	6.5	7.9	15	5	600
	E	265 / 60 / 1	238.5 / 291.5	1	5.0	28.0	0.7	5.7	7.0	15	5	600
018	G	208-230 / 60 / 1	187.2 / 253	1	7.4	33.0	0.9	8.3	10.2	15	5	600
	E	265 / 60 / 1	238.5 / 291.5	1	6.0	28.0	0.7	6.7	8.2	15	5	600
024	G	208-230 / 60 / 1	187.2 / 253	1	12.8	58.3	2.7	15.5	18.7	30	5	600
	E	265 / 60 / 1	238.5 / 291.5	1	9.6	54.0	2.9	12.5	14.9	20	5	600
	F	460 / 60 / 3	414 / 506	1	3.6	28.0	1.6	5.2	6.1	15	5	600
	H	208-230 / 60 / 3	187.2 / 253	1	7.7	55.4	2.7	10.4	12.3	20	5	600
030	G	208-230 / 60 / 1	187.2 / 253	1	14.1	73.0	2.7	16.8	20.3	30	5	600
	E	265 / 60 / 1	238.5 / 291.5	1	11.2	60.0	2.9	14.1	16.9	25	5	600
	F	460 / 60 / 3	414 / 506	1	4.2	28.0	1.6	5.8	6.9	15	5	600
	H	208-230 / 60 / 3	187.2 / 253	1	8.9	58.0	2.7	11.6	13.8	20	5	600
036	G	208-230 / 60 / 1	187.2 / 253	1	16.7	79.0	2.7	19.4	23.6	40	5	600
	E	265 / 60 / 1	238.5 / 291.5	1	13.5	72.0	2.9	16.4	19.8	30	5	600
	F	460 / 60 / 3	414 / 506	1	5.8	38.0	1.6	7.4	8.9	15	5	600
	H	208-230 / 60 / 3	187.2 / 253	1	10.4	73.0	2.7	13.1	15.7	25	5	600
042	G	208-230 / 60 / 1	187.2 / 253	1	17.9	112.0	2.7	20.6	25.1	40	5	600
	F	460 / 60 / 3	414 / 506	1	6.0	44.0	1.6	7.6	9.1	15	5	600
	H	208-230 / 60 / 3	187.2 / 253	1	13.5	88.0	2.7	16.2	19.6	30	5	600
	N	575 / 60 / 3	517.5 / 632.5	1	4.9	34.0	1.4	6.3	7.5	15	5	600
048	G	208-230 / 60 / 1	187.2 / 253	1	21.8	117.0	4.8	26.6	32.1	50	5	600
	F	460 / 60 / 3	414 / 506	1	6.2	41.0	2.4	8.6	10.2	15	5	600
	H	208-230 / 60 / 3	187.2 / 253	1	13.7	83.1	4.8	18.5	21.9	35	5	600
	N	575 / 60 / 3	517.5 / 632.5	1	4.8	33.0	1.8	6.6	7.8	15	5	600
060	G	208-230 / 60 / 1	187.2 / 253	1	26.3	134.0	5.7	32.0	38.6	60	5	600
	F	460 / 60 / 3	414 / 506	1	7.8	52.0	2.5	10.3	12.3	20	5	600
	H	208-230 / 60 / 3	187.2 / 253	1	15.6	110.0	5.7	21.3	25.2	40	5	600
	N	575 / 60 / 3	517.5 / 632.5	1	5.8	38.9	1.9	7.7	9.2	15	5	600

\* 460 volt units require a neutral connection.  
 All "F" voltage units with Constant Volume (CV) ECM require a four wire power supply with neutral.  
 Motors are 265 volt and are wired between one hot leg and neutral.  
 All fuses Class RK-5

Tranquility® Compact (TC) Series

Rev.: January 25, 2024

Electrical Data: Constant Torque (CT) ECM

MODEL	VOLTAGE CODE	RATED VOLTAGE	VOLTAGE MIN/ MAX	COMPRESSOR			FAN MOTOR FLA	TOTAL UNIT FLA	MIN CIRCUIT AMP	MAX FUSE/ HACR	SCCR kA rms symmetrical	SCCR Volts Maximum
				QTY	RLA	LRA						
006	G	208-230 / 60 / 1	187.2 / 253	1	2.6	17.7	2.3	4.9	5.6	15	5	600
	E	265 / 60 / 1	238.5 / 291.5	1	2.6	13.5	2.3	4.9	5.6	15	5	600
009	G	208-230 / 60 / 1	187.2 / 253	1	3.7	22.2	2.3	6.0	6.9	15	5	600
	E	265 / 60 / 1	238.5 / 291.5	1	3.4	18.8	2.3	5.7	6.6	15	5	600
012	G	208-230 / 60 / 1	187.2 / 253	1	5.6	32.5	2.3	7.9	9.3	15	5	600
	E	265 / 60 / 1	238.5 / 291.5	1	4.2	31.5	2.3	6.5	7.6	15	5	600
015	G	208-230 / 60 / 1	187.2 / 253	1	5.6	29.0	2.6	8.2	9.6	15	5	600
	E	265 / 60 / 1	238.5 / 291.5	1	5.0	28.0	1.9	6.9	8.2	15	5	600
018	G	208-230 / 60 / 1	187.2 / 253	1	7.4	33.0	2.6	10.0	11.9	15	5	600
	E	265 / 60 / 1	238.5 / 291.5	1	6.0	28.0	1.9	7.9	9.4	15	5	600
024	G	208-230 / 60 / 1	187.2 / 253	1	12.8	58.3	3.9	16.7	19.9	30	5	600
	E	265 / 60 / 1	238.5 / 291.5	1	9.6	54.0	3.2	12.8	15.2	20	5	600
	F	460 / 60 / 3	414 / 506	1	3.6	28.0	1.1	4.7	5.6	15	5	600
	H	208-230 / 60 / 3	187.2 / 253	1	7.7	55.4	3.9	11.6	13.5	20	5	600
030	G	208-230 / 60 / 1	187.2 / 253	1	14.1	73.0	3.9	18.0	21.5	35	5	600
	E	265 / 60 / 1	238.5 / 291.5	1	11.2	60.0	3.2	14.4	17.2	25	5	600
	F	460 / 60 / 3	414 / 506	1	4.2	28.0	1.1	5.3	6.4	15	5	600
	H	208-230 / 60 / 3	187.2 / 253	1	8.9	58.0	3.9	12.8	15.0	20	5	600
036	G	208-230 / 60 / 1	187.2 / 253	1	16.7	79.0	6.0	22.7	26.9	40	5	600
	E	265 / 60 / 1	238.5 / 291.5	1	13.5	72.0	3.9	17.4	20.8	30	5	600
	F	460 / 60 / 3	414 / 506	1	5.8	38.0	1.5	7.3	8.8	15	5	600
	H	208-230 / 60 / 3	187.2 / 253	1	10.4	73.0	6.0	16.4	19.0	25	5	600
042	G	208-230 / 60 / 1	187.2 / 253	1	17.9	112.0	6.0	23.9	28.4	45	5	600
	F	460 / 60 / 3	414 / 506	1	6.0	44.0	1.5	7.5	9.0	15	5	600
	H	208-230 / 60 / 3	187.2 / 253	1	13.5	88.0	6.0	19.5	22.9	35	5	600
048	G	208-230 / 60 / 1	187.2 / 253	1	21.8	117.0	7.5	29.3	34.8	50	5	600
	F	460 / 60 / 3	414 / 506	1	6.2	41.0	2.1	8.3	9.9	15	5	600
	H	208-230 / 60 / 3	187.2 / 253	1	13.7	83.1	7.5	21.2	24.6	35	5	600
060	G	208-230 / 60 / 1	187.2 / 253	1	26.3	134.0	7.5	33.8	40.4	60	5	600
	F	460 / 60 / 3	414 / 506	1	7.8	52.0	2.1	9.9	11.9	15	5	600
	H	208-230 / 60 / 3	187.2 / 253	1	15.6	110.0	7.5	23.1	27.0	40	5	600

\* 460 volt units require a neutral connection.  
 All "F" voltage units with Constant Volume (CV) ECM require a four wire power supply with neutral.  
 Motors are 265 volt and are wired between one hot leg and neutral.  
 All fuses Class RK-5

### Electrical Data: Constant Volume (CV) ECM

MODEL	VOLTAGE CODE	RATED VOLTAGE	VOLTAGE MIN/ MAX	COMPRESSOR			FAN MOTOR FLA	TOTAL UNIT FLA	MIN CIRCUIT AMP	MAX FUSE/ HACR	SCCR kA rms symetrical	SCCR Volts Maximum
				QTY	RLA	LRA						
006	G	208-230 / 60 / 1	187.2 / 253	1	2.6	17.7	1.5	4.1	4.8	15	5	600
	E	265 / 60 / 1	238.5 / 291.5	1	2.6	13.5	1.4	4.0	4.7	15	5	600
009	G	208-230 / 60 / 1	187.2 / 253	1	3.7	22.2	1.5	5.2	6.1	15	5	600
	E	265 / 60 / 1	238.5 / 291.5	1	3.4	18.8	1.4	4.8	5.7	15	5	600
012	G	208-230 / 60 / 1	187.2 / 253	1	5.6	32.5	2.6	8.2	9.6	15	5	600
	E	265 / 60 / 1	238.5 / 291.5	1	4.2	31.5	2.5	6.7	7.8	15	5	600
015	G	208-230 / 60 / 1	187.2 / 253	1	5.6	29.0	2.6	8.2	9.6	15	5	600
	E	265 / 60 / 1	238.5 / 291.5	1	5.0	28.0	2.4	7.4	8.7	15	5	600
018	G	208-230 / 60 / 1	187.2 / 253	1	7.4	33.0	2.6	10.0	11.9	15	5	600
	E	265 / 60 / 1	238.5 / 291.5	1	6.0	28.0	2.4	8.4	9.9	15	5	600
024	G	208-230 / 60 / 1	187.2 / 253	1	12.8	58.3	3.9	16.7	19.9	30	5	600
	E	265 / 60 / 1	238.5 / 291.5	1	9.6	54.0	3.2	12.8	15.2	20	5	600
	*F	460 / 60 / 3	414 / 506	1	3.6	28.0	3.2	6.8	7.7	15	5	600
	H	208-230 / 60 / 3	187.2 / 253	1	7.7	55.4	3.9	11.6	13.5	20	5	600
030	G	208-230 / 60 / 1	187.2 / 253	1	14.1	73.0	3.9	18.0	21.5	35	5	600
	E	265 / 60 / 1	238.5 / 291.5	1	11.2	60.0	3.2	14.4	17.2	25	5	600
	*F	460 / 60 / 3	414 / 506	1	4.2	28.0	3.2	7.4	8.5	15	5	600
	H	208-230 / 60 / 3	187.2 / 253	1	8.9	58.0	3.9	12.8	15.0	20	5	600
036	G	208-230 / 60 / 1	187.2 / 253	1	16.7	79.0	6.0	22.7	26.9	40	5	600
	E	265 / 60 / 1	238.5 / 291.5	1	13.5	72.0	4.8	18.3	21.7	35	5	600
	*F	460 / 60 / 3	414 / 506	1	5.8	38.0	4.8	10.6	12.1	15	5	600
	H	208-230 / 60 / 3	187.2 / 253	1	10.4	73.0	6.0	16.4	19.0	25	5	600
042	G	208-230 / 60 / 1	187.2 / 253	1	17.9	112.0	6.0	23.9	28.4	45	5	600
	F	460 / 60 / 3	414 / 506	1	6.0	44.0	4.8	10.8	12.3	15	5	600
	H	208-230 / 60 / 3	187.2 / 253	1	13.5	88.0	6.0	19.5	22.9	35	5	600
048	G	208-230 / 60 / 1	187.2 / 253	1	21.8	117.0	7.5	29.3	34.8	50	5	600
	*F	460 / 60 / 3	414 / 506	1	6.2	41.0	6.2	12.4	14.0	15	5	600
	H	208-230 / 60 / 3	187.2 / 253	1	13.7	83.1	7.5	21.2	24.6	35	5	600
060	G	208-230 / 60 / 1	187.2 / 253	1	26.3	134.0	7.5	33.8	40.4	60	5	600
	*F	460 / 60 / 3	414 / 506	1	7.8	52.0	6.0	13.8	15.8	20	5	600
	H	208-230 / 60 / 3	187.2 / 253	1	15.6	110.0	7.5	23.1	27.0	40	5	600

\* 460 volt units require a neutral connection.  
 All "F" voltage units with Constant Volume (CV) ECM require a four wire power supply with neutral.  
 Motors are 265 volt and are wired between one hot leg and neutral.  
 All fuses Class RK-5

Tranquility® Compact (TC) Series

Rev.: January 25, 2024

Electrical: Line Voltage

**WARNING!** Disconnect electrical power source to prevent injury or death from electrical shock.

**CAUTION!** Use only copper conductors for field installed electrical wiring. Unit terminals are not designed to accept other types of conductors.

**Electrical - Line Voltage** - All field installed wiring, including electrical ground, must comply with the National Electrical Code as well as all applicable local codes. Refer to the unit electrical data for fuse sizes. Consult wiring diagram for field connections that must be made by the installing (or electrical) contractor. All final electrical connections must be made with a length of flexible conduit to minimize vibration and sound transmission to the building.

**General Line Voltage Wiring** - Be sure the available power is the same voltage and phase shown on the unit serial plate. Line and low voltage wiring must be done in accordance with local codes or the National Electric Code, whichever is applicable.

**Figure 14: Single Phase Line Voltage Field Wiring. Three phase wiring is similar except that all three power wires are directly connected to the contactor.**

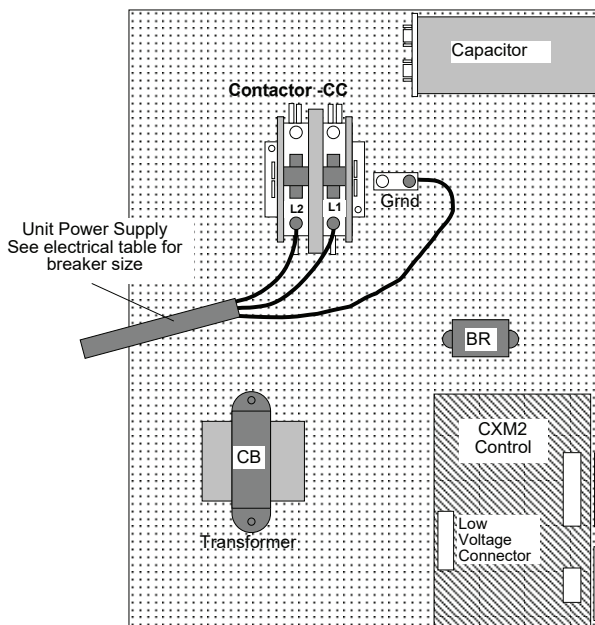

**Note:** 460V units with Constant Volume (CV) ECM motor require a neutral wire.

**Power Connection** - Line voltage connection is made by connecting the incoming line voltage wires to the “L” side of the contractor as shown in Figure 14. Consult electrical data tables for correct fuse size.

**Transformer** - All 208/230 voltage units are factory wired for 208 volt. If supply voltage is 230 volt, installer must rewire transformer. See wire diagram for connections.

**Blower Speed Selection** – Units with PSC Motor - PSC (Permanent Split Capacitor) blower fan speed can be changed by moving the blue wire on the fan motor terminal block to the desired speed as shown in Figure 15. Most ClimateMaster units are shipped on the medium speed tap. Consult submittal data or engineering design guide for specific unit airflow tables. Typical unit design delivers rated airflow at nominal static (0.15 in. w.g. [37Pa]) on medium speed and rated airflow at a higher static (0.4 to 0.5 in. w.g. [100 to 125 Pa]) on high speed for applications where higher static is required. Low speed will deliver approximately 85% of rated airflow at 0.10 in. w.g. [25 Pa]. An optional high static blower is available on some models.

**Special Note for AHRI Testing:** To achieve rated airflow for AHRI testing purposes on all PSC products, it is necessary to change the fan speed to “HI” speed. When the heat pump has experienced less than 100 operational hours and the coil has not had sufficient time to be “seasoned”, it is necessary to clean the coil with a mild surfactant such as Calgon to remove the oils left by manufacturing processes and enable the condensate to properly “sheet” off of the coil.

**Figure 15: PSC Motor Speed Selection**

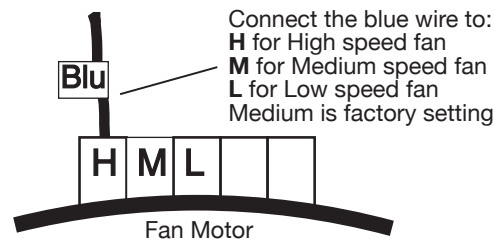

## Electrical: Power & Low Voltage Wiring

### ELECTRICAL - LOW VOLTAGE WIRING

**Thermostat Connections** - The thermostat should be wired directly to the CXM2 or DXM2.5 board. See “Electrical – Thermostat” for specific terminal connections. Review the appropriate AOM (Application, Operation and Maintenance) manual for units with DDC controls.

**Low Water Temperature Cutout Selection** - The CXM2/DXM2.5 control allows the field selection of low water (or water-antifreeze solution) temperature limit by clipping jumper JW3, which changes the sensing temperature associated with thermistor LT1. Note that the LT1 thermistor is located on the refrigerant line between the coaxial heat exchanger and expansion device (TXV). Therefore, LT1 is sensing refrigerant temperature, not water temperature, which is a better indication of how water flow rate/temperature is affecting the refrigeration circuit.

The factory setting for LT1 is for systems using water (30°F [-1.1°C] refrigerant temperature). In low water temperature (extended range) applications with antifreeze (most ground loops), jumper JW3 should be clipped as shown in Figure 16 to change the setting to 10°F [-12.2°C] refrigerant temperature, a more suitable temperature when using an antifreeze solution. All ClimateMaster units operating with entering water temperatures below 60°F [15.6°C] must include the optional water/refrigerant circuit insulation package to prevent internal condensation.

**Models with Waterside Economizer** - Assemble controller to DIN rail connect molex connector. Factory settings are 45°F (7.2°C), valve opens, closes at 55°F (12.8°C), and 5 minute short cycle delay. Settings are adjustable.

Figure 16: LT1 Limit Setting

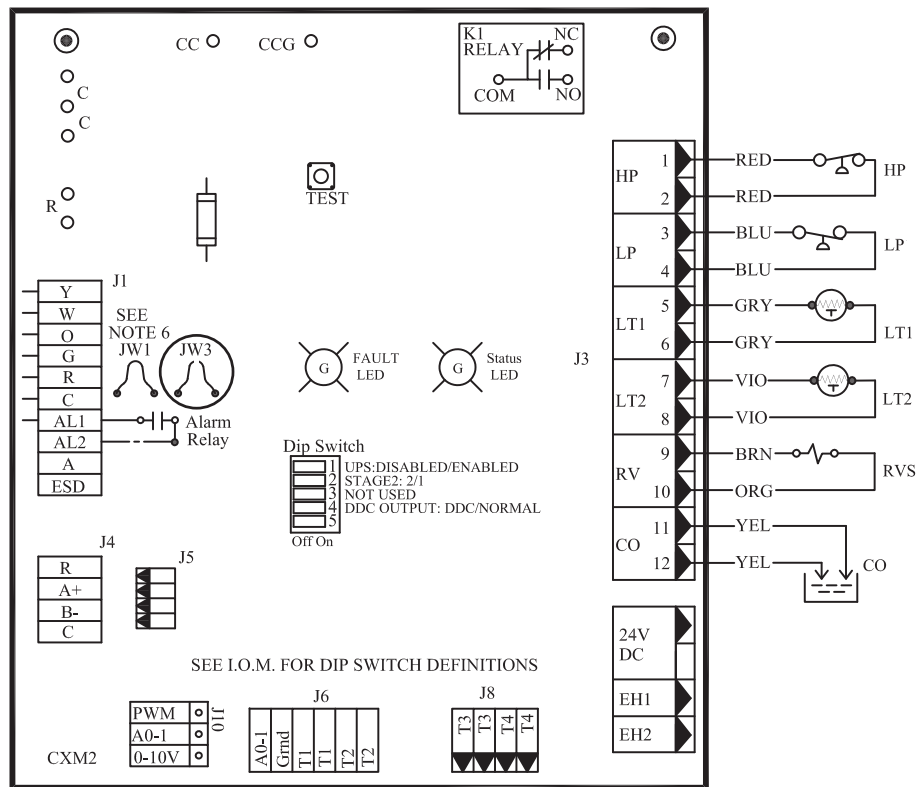

Tranquility® Compact (TC) Series

Rev.: January 25, 2024

Electrical: Low Voltage Wiring

Accessory Connections

A terminal paralleling the compressor contactor coil has been provided on the CXM2/DXM2.5 control. Terminal “A” is designed to control accessory devices, such as water valves. Note: This terminal should be used only with 24 Volt signals and not line voltage. Terminal “A” is energized with the compressor contactor. See Figure 17 or the specific unit wiring diagram for details.

Low Voltage VA Ratings

Component	VA
Typical Blower Relay	6 - 7
Typical Reversing Valve Solenoid	4 - 6
30A Compressor Contactor	6 - 9
Subtotal	16 - 22
+ CXM2 board (5 - 9 VA)*	21 - 31
Remaing VA for Accessories	19 - 29
+ DXM2.5 board (8 - 12 VA)*	24 - 34
Remaing VA for Accessories	41 - 51

\*Standard transformer for CXM2 board is 50VA. Optional DXM2.5 board and/or DDC controls include 75VA transformer.

Figure 17: Accessory Wiring Terminal Strip

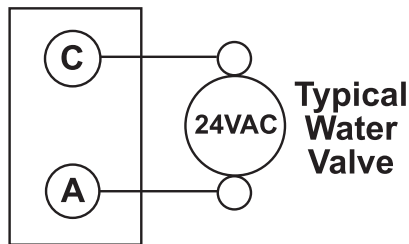

**Water Solenoid Valves** - An external solenoid valve(s) should be used on ground water installations to shut off flow to the unit when the compressor is not operating. A slow closing valve may be required to help reduce water hammer. Figure 18 shows typical wiring for a 24VAC external solenoid valve. Figures 18 and 19 illustrate typical slow closing water control valve wiring for Taco 500 series (ClimateMaster P/N AVM) and Taco SBV series valves. Slow closing valves take approximately 60 seconds to open (very little water will flow before 45 seconds). Once fully open, an end switch allows the compressor to be energized. Only relay or triac based electronic thermostats should be used with slow closing valves. When wired as shown, the slow closing valve will operate properly with the following notations:

1. The valve will remain open during a unit lockout.
2. The valve will draw approximately 25-35 VA through the “Y” signal of the thermostat.

**Note: This valve can overheat the anticipator of an electromechanical thermostat. Therefore, only relay or triac based thermostats should be used.**

Figure 18: Accessory Motorized Water Valve - Typical Wiring Example #1

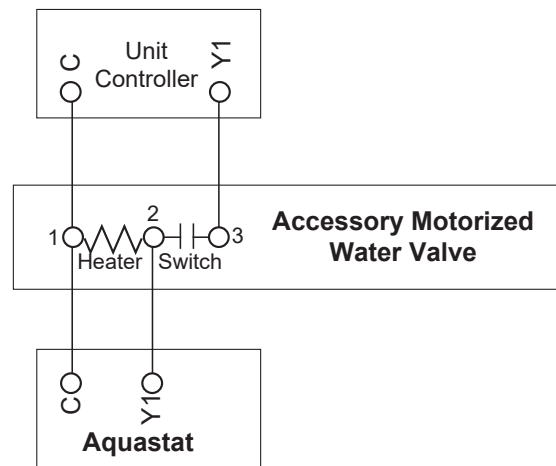
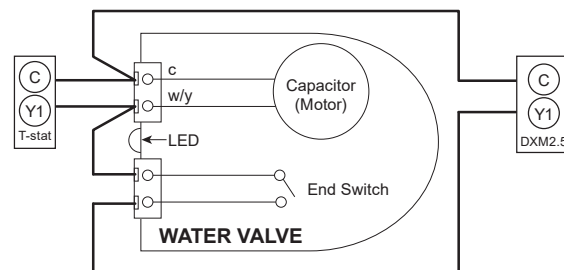

Figure 19: Accessory Motorized Water Valve - Typical Wiring Example #2



## Electrical: Thermostat Wiring

**Thermostat Installation** - The thermostat should be located on an interior wall in a larger room, away from supply duct drafts. DO NOT locate the thermostat in areas subject to sunlight, drafts or on external walls. The wire access hole behind the thermostat may in certain cases need to be sealed to prevent erroneous temperature measurement. Position the thermostat back plate against the wall so that it appears level and so the thermostat wires protrude through the middle of the back plate. Mark the position of the back plate mounting holes and drill holes with a 3/16" (5mm) bit. Install supplied anchors and secure plate to the wall. Thermostat wire must be 18 AWG wire. Representative thermostat wiring is shown in Figure 20 however, actual wiring connections should be determined from the thermostat IOM and or unit wiring diagram. Practically any heat pump thermostat will work with water source heat pump units, provided it has the correct number of heating and cooling stages.

Figure 20: Units with PSC Fan

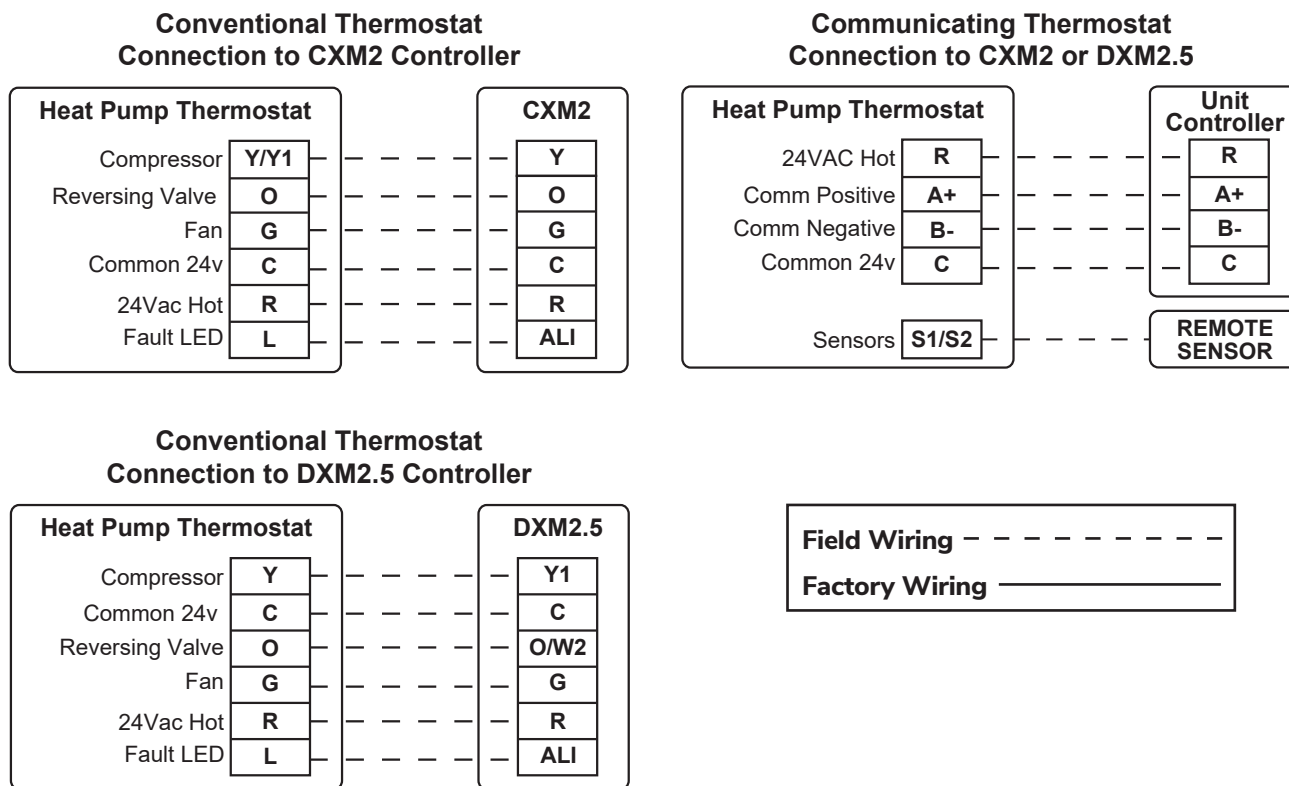

Tranquility® Compact (TC) Series

Rev.: January 25, 2024

Blower Performance Data – TC006

Rated CFM	Min CFM	Motor Type	Motor Speed Setting	External Static Pressure (in. wg)													
					0.1	0.2	0.3	0.4	0.5	0.6	0.7	0.8	0.9	1.0			
225	150	PSC	Low	CFM	210	190	160										
			Medium	CFM	260	240	210	190									
			High	CFM	310	290	270	230	180								
225	150	Constant Torque ECM	1	RPM	944	1028	1114	1206	1297								
				Power (W)	22	24	25	28	30								
				CFM	225	207	187	169	150								
			2	RPM				1201	1280	1362	1441	1523	1608	1694			
				Power (W)				34	37	39	42	44	48	51			
				CFM				233	217	201	185	173	164	150			
			3	RPM						1324	1400	1476	1551	1628	1709	1786	
				Power (W)						43	45	48	51	54	58	61	
				CFM						241	227	212	200	188	179	168	
			4	RPM									1516	1588	1658	1730	1799
				Power (W)									55	58	61	65	67
				CFM									240	227	216	205	193
225	150	Constant Volume ECM	Minimum CFM	RPM	763	933	1078	1201	1314	1417	1519	1615	1712				
				Power (W)	16	21	27	40	36	41	46	52	59				
				CFM	150	150	150	150	150	150	150	150	150	150			
			Default CFM	RPM	983	1102	1211	1319	1419	1516	1610	1708	1783	1817			
				Power (W)	29	35	41	47	53	60	67	76	81	77			
				CFM	225	225	225	225	225	225	225	225	225	225	225	255	
			Maximum CFM	RPM	1053	1162	1265	1366	1462	1553	1648	1733	1802	1817			
				Power (W)	35	41	47	53	60	67	76	84	88	78			
				CFM	250	250	250	250	250	250	250	250	250	250	250	250	

See ECM control section for details on setting airflow.  
 Airflow is controlled within 5% up to the Max ESP shown with wet coil.  
 Do not select Dehumidification mode if HP CFM is on setting 1.  
 Black areas denote ESP where operation is not recommended.  
 PSC: Units factory shipped on medium speed. Other speeds require field selection.  
 CT ECM: Units factory shipped on Speed Tap 2 for Fan-Only and Speed Tap 3 for Heating/Cooling.  
 All airflow is rated and shown above at the lower voltage if unit is dual voltage rated, e.g. 208V for 208-230V units.  
 Only two speed PSC fan (H & M) available on 575V units.  
 Performance stated is at the rated power supply. Performance may vary as the power supply varies from the rated.  
 All data is shown wet coil with clean 1" filter.  
 All data is ran at 80 °F DB and 67 °F WB.  
 CFM Tolerance is 7%.  
 RPM/Watt Tolerance 10%.

Blower Performance Data – TC009

Rated CFM	Min CFM	Motor Type	Motor Speed Setting	External Static Pressure (in. wg)											
				0.1	0.2	0.3	0.4	0.5	0.6	0.7	0.8	0.9	1.0		
325	225	PSC	Low	CFM	340	322	300	260							
			Medium	CFM	390	360	320	290							260
			High	CFM	410	380	350	320							280
325	225	Constant Torque ECM	1	RPM	1137	1203	1266	1344	1413						
				Power (W)	40	42	44	47	49						
				CFM	294	278	259	245	230						
			2	RPM	1361	1413	1464	1503	1577	1640	1700	1751	1803	1831	
				Power (W)	67	70	73	74	79	82	85	88	90	85	
				CFM	370	357	343	326	318	302	291	278	265	235	
			3	RPM				1538	1589	1642	1695	1749	1812	1829	1847
				Power (W)				86	88	91	95	98	101	96	90
				CFM				370	358	346	334	322	307	280	247
			4	RPM							1835	1853	1869	1875	
				Power (W)							120	113	107	102	
				CFM							340	309	276	234	
325	225	Constant Volume ECM	Minimum CFM	RPM	929	1083	1210	1324	1432	1529	1595	1723	1792		
				Power (W)	25	32	39	45	53	60	66	78	83		
				CFM	225	225	225	225	225	225	225	225	225		
			Default CFM	RPM	1209	1326	1430	1535	1635	1732	1792	1801	1811		
				Power (W)	49	58	67	77	88	100	105	95	88		
				CFM	325	325	325	325	325	325	325	325	325		
			Maximum CFM	RPM	1691	1753	1765	1769	1778	1784	1793	1803	1813		
				Power (W)	126	134	131	125	119	118	105	98	90		
				CFM	375	375	375	375	375	375	375	375	375		

See ECM control section for details on setting airflow.  
 Airflow is controlled within 5% up to the Max ESP shown with wet coil.  
 Do not select Dehumidification mode if HP CFM is on setting 1.  
 Black areas denote ESP where operation is not recommended.  
 PSC: Units factory shipped on medium speed. Other speeds require field selection.  
 CT ECM: Units factory shipped on Speed Tap 2 for Fan-Only and Speed Tap 3 for Heating/Cooling.  
 All airflow is rated and shown above at the lower voltage if unit is dual voltage rated, e.g. 208V for 208-230V units.  
 Only two speed PSC fan (H & M) available on 575V units.  
 Performance stated is at the rated power supply. Performance may vary as the power supply varies from the rated.  
 All data is shown wet coil with clean 1" filter.  
 All data is ran at 80 °F DB and 67 °F WB.  
 CFM Tolerance is 7%.  
 RPM/Watt Tolerance 10%.

Tranquility® Compact (TC) Series

Rev.: January 25, 2024

Blower Performance Data – TC012

Rated CFM	Min CFM	Motor Type	Motor Speed Setting	External Static Pressure (in. wg)											
				0.1	0.2	0.3	0.4	0.5	0.6	0.7	0.8	0.9	1.0		
380	300	PSC	Low	CFM	360	350	320	310							
			Medium	CFM	420	400	380	360	340						
			High	CFM	470	450	430	400	380	320					
380	300	Constant Torque ECM	1	RPM	1338	1385	1436	1491	1551						
				Power (W)	64	66	69	71	75						
				CFM	358	345	332	319	305						
			2	RPM	1477	1517	1561	1612	1660	1711	1769	1819			
				Power (W)	86	88	91	94	97	100	103	104			
				CFM	400	388	377	365	354	342	328	309			
			3	RPM	1632	1672	1709	1747	1785	1820	1835	1856			
				Power (W)	116	119	122	124	126	126	121	114			
				CFM	449	437	427	414	401	385	359	327			
			4	RPM	1698	1729	1765	1798	1821	1836	1842	1843			
				Power (W)	131	133	135	137	135	130	123	110			
				CFM	467	456	444	433	414	390	361	318			
380	300	Constant Volume ECM	Minimum CFM	RPM	1258	1368	1464	1555	1635	1718	1793	1830			
				Power (W)	55	64	73	81	90	99	107	106			
				CFM	300	300	300	300	300	300	300	300			
			Default CFM	RPM	1598	1672	1743	1813	1831	1845	1859	1875			
				Power (W)	105	115	125	135	132	127	123	118			
				CFM	380	380	380	380	380	380	380	380			
			Maximum CFM	RPM	1798	1823	1834	1844	1858	1872	1886	1901	1920		
				Power (W)	147	149	146	143	139	134	130	126	120		
				CFM	415	415	415	415	415	415	415	415	415		

See ECM control section for details on setting airflow.  
 Airflow is controlled within 5% up to the Max ESP shown with wet coil.  
 Do not select Dehumidification mode if HP CFM is on setting 1.  
 Black areas denote ESP where operation is not recommended.  
 PSC: Units factory shipped on medium speed. Other speeds require field selection.  
 CT ECM: Units factory shipped on Speed Tap 2 for Fan-Only and Speed Tap 3 for Heating/Cooling.  
 All airflow is rated and shown above at the lower voltage if unit is dual voltage rated, e.g. 208V for 208-230V units.  
 Only two speed PSC fan (H & M) available on 575V units.  
 Performance stated is at the rated power supply. Performance may vary as the power supply varies from the rated.  
 All data is shown wet coil with clean 1" filter.  
 All data is ran at 80 °F DB and 67 °F WB.  
 CFM Tolerance is 7%.  
 RPM/Watt Tolerance 10%.

Blower Performance Data – TC015

Rated CFM	Min CFM	Motor Type	Motor Speed Setting	External Static Pressure (in. wg)																
				0.1	0.2	0.3	0.4	0.5	0.6	0.7	0.8	0.9	1.0							
525	375	PSC	Low	CFM	503	490	479	439												
			Medium	CFM	595	575	562	510	451											
			High	CFM				581	510	386										
525	375	PSC - High Static	Low	CFM	462	456	443	425	385											
			Medium	CFM	546	539	531	513	481	414										
			High	CFM						547	426									
525	375	Constant Torque ECM	1	RPM	655	614	701	770	851	937										
				Power (W)	67	55	62	68	75	82										
				CFM	648	588	542	493	441	378										
			2	RPM	655	720	799	863	946	1021	1078									
				Power (W)	67	74	81	87	95	102	108									
				CFM	648	608	557	514	460	402	354									
			3	RPM	687	744	822	883	950	1032	1098	1150								
				Power (W)	79	86	94	101	107	117	124	130								
				CFM	695	659	611	570	526	475	422	377								
			4	RPM	716	771	844	906	965	1037	1110	1170	1219							
				Power (W)	92	98	107	114	121	129	138	145	151							
				CFM	737	705	661	622	582	534	482	438	396							
			5	RPM	763	790	851	924	978	1039	1113	1175	1233	1281						
				Power (W)	106	110	117	126	133	141	151	159	165	172						
				CFM	745	745	708	662	626	585	535	488	444	402						
525	375	Constant Volume ECM	Minimum CFM	RPM		617	741	848	945	1028	1103	1171								
				Power (W)		36	52	68	84	99	114	129								
				CFM		375	375	375	375	375	375	375	375							
			Default CFM	RPM		661	767	859	944	1028	1107	1179	1247							
				Power (W)		55	74	90	108	127	147	166	186							
				CFM		525	525	525	525	525	525	525	525	525						
			Maximum CFM	RPM	586	695	795	882	963	1038	1111	1180	1248	1312						
				Power (W)	54	73	93	112	132	152	173	194	216	238						
				CFM	625	625	625	625	625	625	625	625	625	625	625	625	625	625	625	

See ECM control section for details on setting airflow.  
 Airflow is controlled within 5% up to the Max ESP shown with wet coil.  
 Do not select Dehumidification mode if HP CFM is on setting 1.  
 Black areas denote ESP where operation is not recommended.  
 PSC: Units factory shipped on medium speed. Other speeds require field selection.  
 CT ECM: Units factory shipped on Speed Tap 2 for Fan-Only and Speed Tap 3 for Heating/Cooling.  
 All airflow is rated and shown above at the lower voltage if unit is dual voltage rated, e.g. 208V for 208-230V units.  
 Only two speed PSC fan (H & M) available on 575V units.  
 Performance stated is at the rated power supply. Performance may vary as the power supply varies from the rated.  
 All data is shown wet coil with clean 1" filter.  
 All data is ran at 80 °F DB and 67 °F WB.  
 CFM Tolerance is 7%.  
 RPM/Watt Tolerance 10%.

Tranquility® Compact (TC) Series

Rev.: January 25, 2024

Blower Performance Data – TC018

Rated CFM	Min CFM	Motor Type	Motor Speed Setting	External Static Pressure (in. wg)											
				0.1	0.2	0.3	0.4	0.5	0.6	0.7	0.8	0.9	1.0		
600	450	PSC	Low	CFM	524	509	493	451							
			Medium	CFM	611	588	564	514							
			High	CFM	704	668	643	617	504						
600	450	PSC - High Static	Low	CFM	461										
			Medium	CFM	553	543	533	506	468						
			High	CFM	670	661	645	628	587	534					
600	450	Constant Torque ECM	1	RPM	693	763	837	882							
				Power (W)	73	78	85	90							
				CFM	600	558	518	491							
			2	RPM	745	801	873	904	966	1031	1098				
				Power (W)	92	99	107	109	116	123	131				
				CFM	676	641	599	570	536	498	452				
			3	RPM	782	831	890	958	992	1048	1106	1171	1223		
				Power (W)	112	118	126	135	140	147	155	163	170		
				CFM	741	713	677	640	619	586	554	512	471		
			4	RPM	833	875	924	986	1046	1072	1124	1177	1236	1290	
				Power (W)	138	144	152	161	170	174	181	190	199	207	
				CFM	802	780	751	714	680	662	633	603	567	529	
			5	RPM	895	924	968	1016	1078	1133	1151	1199	1249	1302	
				Power (W)	170	175	182	190	201	210	214	222	231	240	
				CFM	854	848	820	791	754	724	711	683	655	625	
600	450	Constant Volume ECM	Minimum CFM	RPM					1096	1179	1275	1361			
				Power (W)					111	132	157	180			
				CFM					450	450	450	450			
			Default CFM	RPM	847	918	971	1095	1208	1297	1360	1418	1467		
				Power (W)	85	101	113	145	178	206	228	248	266		
				CFM	600	600	600	600	600	600	600	600	600		
			Maximum CFM	RPM	1036	1080	1131	1172	1213	1317	1406	1494			
				Power (W)	157	171	186	200	214	251	286	323			
				CFM	750	750	750	750	750	750	750	750			

See ECM control section for details on setting airflow.  
 Airflow is controlled within 5% up to the Max ESP shown with wet coil.  
 Do not select Dehumidification mode if HP CFM is on setting 1.  
 Black areas denote ESP where operation is not recommended.  
 PSC: Units factory shipped on medium speed. Other speeds require field selection.  
 CT ECM: Units factory shipped on Speed Tap 2 for Fan-Only and Speed Tap 3 for Heating/Cooling.  
 All airflow is rated and shown above at the lower voltage if unit is dual voltage rated, e.g. 208V for 208-230V units.  
 Only two speed PSC fan (H & M) available on 575V units.  
 Performance stated is at the rated power supply. Performance may vary as the power supply varies from the rated.  
 All data is shown wet coil with clean 1" filter.  
 All data is ran at 80 °F DB and 67 °F WB.  
 CFM Tolerance is 7%.  
 RPM/Watt Tolerance 10%.

Blower Performance Data – TC024

Rated CFM	Min CFM	Motor Type	Motor Speed Setting		External Static Pressure (in. wg)												
					0.1	0.2	0.3	0.4	0.5	0.6	0.7	0.8	0.9	1.0			
850	600	PSC	Low	CFM	760	741	722	694	665	618							
			Medium	CFM	941	912	874	836	789	732	665						
			High	CFM					950	884	827	732	656				
850	600	PSC - High Static	Low	CFM	979		931	884	827	751	675						
			Medium	CFM				988	922	846	713						
			High	CFM						979	903	798	665				
800	600	Constant Torque ECM	1	RPM	817	865	915	973									
				Power (W)	116	122	128	135									
				CFM	755	728	695	653									
			2	RPM	877	920	966	1012	1070	1142	1198						
				Power (W)	146	152	159	166	174	185	193						
				CFM	836	810	782	750	708	657	616						
			3	RPM	938	974	1017	1057	1102	1158	1227	1283	1323	1355			
				Power (W)	181	187	194	201	209	218	230	239	246	252			
				CFM	910	887	861	834	804	762	714	674	642	619			
			4	RPM	1015	1048	1084	1121	1159	1199	1244	1309	1369	1412			
				Power (W)	232	240	247	254	262	270	278	291	303	312			
				CFM	996	975	952	929	904	876	845	798	755	725			
			5	RPM						1219	1255	1293	1331	1384	1446		
				Power (W)						323	331	340	348	361	374		
				CFM						999	975	951	923	884	840		
800	600	Constant Volume ECM	Minimum CFM	RPM	706	788	867	941	1013	1080	1143	1203	1259	1311			
				Power (W)	71	89	107	124	141	159	177	195	213	230			
				CFM	600	600	600	600	600	600	600	600	600	600	600		
			Default CFM	RPM	882	943	1002	1059	1114	1168	1220	1271	1319	1366			
				Power (W)	145	165	185	205	225	245	266	285	306	326			
				CFM	800	800	800	800	800	800	800	800	800	800	800		
			Maximum CFM	RPM	1077	1122	1162	1200	1233	1263	1288	1310	1329	1343			
				Power (W)	284	300	315	332	351	364	379	396	412	428			
				CFM	1000	1000	1000	1000	1000	1000	1000	1000	1000	1000	1000		

See ECM control section for details on setting airflow.  
 Airflow is controlled within 5% up to the Max ESP shown with wet coil.  
 Do not select Dehumidification mode if HP CFM is on setting 1.  
 Black areas denote ESP where operation is not recommended.  
 PSC: Units factory shipped on medium speed. Other speeds require field selection.  
 CT ECM: Units factory shipped on Speed Tap 2 for Fan-Only and Speed Tap 3 for Heating/Cooling.  
 All airflow is rated and shown above at the lower voltage if unit is dual voltage rated, e.g. 208V for 208-230V units.  
 Only two speed PSC fan (H & M) available on 575V units.  
 Performance stated is at the rated power supply. Performance may vary as the power supply varies from the rated.  
 All data is shown wet coil with clean 1" filter.  
 All data is ran at 80 °F DB and 67 °F WB.  
 CFM Tolerance is 7%.  
 RPM/Watt Tolerance 10%.

Tranquility® Compact (TC) Series

Rev.: January 25, 2024

Blower Performance Data – TC030

Rated CFM	Min CFM	Motor Type	Motor Speed Setting	External Static Pressure (in. wg)											
				0.1	0.2	0.3	0.4	0.5	0.6	0.7	0.8	0.9	1.0		
1000	750	PSC	Low	CFM	1017	979	931	884	827	751					
			Medium	CFM	1140	1093	1036	988	922	846					
			High	CFM				1102	1045	979	903	798			
1000	750	PSC - High Static	Low	CFM	979	941	912	865	798						
			Medium	CFM				1074	979	884	779				
			High	CFM					1102	988	874	760			
1000	750	Constant Torque ECM	1	RPM	880	925	994	1049	1101						
				Power (W)	158	165	176	184	192						
				CFM	904	873	832	796	763						
			2	RPM	956	998	1038	1105	1156	1203	1248	1295	1344		
				Power (W)	211	219	227	240	250	258	267	276	285		
				CFM	1020	992	965	927	894	864	835	805	771		
			3	RPM	1034	1072	1110	1145	1209	1250	1303	1346	1387	1422	
				Power (W)	280	289	298	306	321	330	342	351	361	368	
				CFM	1139	1113	1089	1064	1027	999	966	937	910	879	
			4	RPM	1095	1130	1166	1201	1237	1299	1337	1387	1428	1465	
				Power (W)	336	346	355	364	374	389	399	413	423	430	
				CFM	1216	1193	1168	1146	1123	1086	1062	1028	1002	975	
			5	RPM					1268	1301	1333	1394	1426	1473	1491
				Power (W)					452	462	471	490	499	508	478
				CFM					1250	1229	1208	1173	1151	1112	1036
1000	750	Constant Volume ECM	Minimum CFM	RPM	872	928	990	1046	1096	1143	1192	1238	1282	1327	
				Power (W)	71	89	108	127	145	162	181	199	217	235	
				CFM	750	750	750	750	750	750	750	750	750	750	
			Default CFM	RPM	1131	1177	1218	1252	1295	1337	1381	1415			
				Power (W)	251	274	296	315	337	362	387	407			
				CFM	1000	1000	1000	1000	1000	1000	1000	1000			
			Maximum CFM	RPM	1260	1299	1334	1373	1403						
				Power (W)	388	410	431	453	471						
				CFM	1150	1150	1150	1150	1150						

See ECM control section for details on setting airflow.  
 Airflow is controlled within 5% up to the Max ESP shown with wet coil.  
 Do not select Dehumidification mode if HP CFM is on setting 1.  
 Black areas denote ESP where operation is not recommended.  
 PSC: Units factory shipped on medium speed. Other speeds require field selection.  
 CT ECM: Units factory shipped on Speed Tap 2 for Fan-Only and Speed Tap 3 for Heating/Cooling.  
 All airflow is rated and shown above at the lower voltage if unit is dual voltage rated, e.g. 208V for 208-230V units.  
 Only two speed PSC fan (H & M) available on 575V units.  
 Performance stated is at the rated power supply. Performance may vary as the power supply varies from the rated.  
 All data is shown wet coil with clean 1" filter.  
 All data is ran at 80 °F DB and 67 °F WB.  
 CFM Tolerance is 7%.  
 RPM/Watt Tolerance 10%.

Blower Performance Data – TC036

Rated CFM	Min CFM	Motor Type	Motor Speed Setting	External Static Pressure (in. wg)										
				0.1	0.2	0.3	0.4	0.5	0.6	0.7	0.8	0.9	1.0	
1150	900	PSC	Low	CFM	970	960	951	941	902					
			Medium	CFM	1106	1096	1086	1067	1009	912				
			High	CFM	1436	1387	1329	1280	1174	1077	931			
1150	900	PSC - High Static	Low	CFM	980	970	960	931	902					
			Medium	CFM	1300	1280	1261	1222	1193	1116	1038			
			High	CFM					1484	1426	1358	1251	1135	931
1150	900	Constant Torque ECM	1	RPM	842	891	945							
				Power (W)	166	175	184							
				CFM	974	941	904							
			2	RPM	936	983	1028	1075	1125	1167	1203	1241		
				Power (W)	241	251	261	272	282	292	299	307		
				CFM	1132	1103	1074	1041	1005	973	944	916		
			3	RPM	988	1032	1076	1117	1160	1205	1246	1282	1315	1354
				Power (W)	294	304	316	326	337	349	359	367	375	385
				CFM	1271	1242	1214	1185	1153	1118	1083	1056	1029	999
			4	RPM	1056	1090	1130	1170	1208	1250	1292	1332	1370	1403
				Power (W)	376	387	399	409	421	433	446	457	468	478
				CFM	1403	1377	1351	1324	1295	1268	1233	1201	1169	1143
			5	RPM			1193	1228	1265	1295	1323	1358	1392	1419
				Power (W)			499	510	523	524	521	519	516	514
				CFM			1485	1460	1434	1396	1347	1295	1240	1194
1150	900	Constant Volume ECM	Minimum CFM	RPM	682	788	898	976	1043	1107	1170	1230	1297	1371
				Power (W)	105	132	164	188	211	233	257	280	307	339
				CFM	900	900	900	900	900	900	900	900	900	900
			Default CFM	RPM	830	895	961	1054	1145	1209	1267	1321	1371	1419
				Power (W)	205	232	261	303	349	382	415	446	475	505
				CFM	1150	1150	1150	1150	1150	1150	1150	1150	1150	1150
			Maximum CFM	RPM	1042	1040	1095	1149	1199	1273	1355	1420	1459	1493
				Power (W)	406	403	438	474	511	564	629	680	692	691
				CFM	1500	1500	1500	1500	1500	1500	1500	1500	1500	1500

See ECM control section for details on setting airflow.  
 Airflow is controlled within 5% up to the Max ESP shown with wet coil.  
 Do not select Dehumidification mode if HP CFM is on setting 1.  
 Black areas denote ESP where operation is not recommended.  
 PSC: Units factory shipped on medium speed. Other speeds require field selection.  
 CT ECM: Units factory shipped on Speed Tap 2 for Fan-Only and Speed Tap 3 for Heating/Cooling.  
 All airflow is rated and shown above at the lower voltage if unit is dual voltage rated, e.g. 208V for 208-230V units.  
 Only two speed PSC fan (H & M) available on 575V units.  
 Performance stated is at the rated power supply. Performance may vary as the power supply varies from the rated.  
 All data is shown wet coil with clean 1" filter.  
 All data is ran at 80 °F DB and 67 °F WB.  
 CFM Tolerance is 7%.  
 RPM/Watt Tolerance 10%.

Tranquility® Compact (TC) Series

Rev.: January 25, 2024

Blower Performance Data – TC041

Rated CFM	Min CFM	Motor Type	Motor Speed Setting	External Static Pressure (in. wg)											
				0.1	0.2	0.3	0.4	0.5	0.6	0.7	0.8	0.9	1.0		
1125	845	PSC	Low	CFM	1008	971	[Black Area]								
			Medium	CFM	1142	1090	1023	[Black Area]							
			High	CFM	1269	1198	1114	1018	[Black Area]						

Airflow is controlled within 5% up to the Max ESP shown with wet coil.  
 Do not select Dehumidification mode if HP CFM is on setting 1.  
 Black areas denote ESP where operation is not recommended.  
 Units factory shipped on medium speed. Other speeds require field selection.  
 All airflow is rated and shown above at the lower voltage if unit is dual voltage rated, e.g. 208V for 208-230V units.  
 Only two speed fan (H & M) available on 575V units.  
 Performance stated is at the rated power supply. Performance may vary as the power supply varies from the rated.  
 All data is shown wet coil with clean 1" filter.  
 All data is ran at 80 °F DB and 67 °F WB.  
 CFM Tolerance is 7%.  
 RPM/Watt Tolerance 10%.

Blower Performance Data – TC042

Rated CFM	Min CFM	Motor Type	Motor Speed Setting	External Static Pressure (in. wg)													
				0.1	0.2	0.3	0.4	0.5	0.6	0.7	0.8	0.9	1.0				
1400	1050	PSC	Low	CFM	1074	1064	[Black]										
			Medium	CFM	1368	1321	1273	1207	1131	1064	[Black]						
			High	CFM	1501	1444	1378	1302	1226	1131	[Black]						
1400	1050	PSC - High Static	Low	CFM	[Black]												
			Medium	CFM	1302	1283	1254	1235	1188	1121	[Black]						
			High	CFM	[Black]	1473	1444	1397	1378	1311	1178	[Black]					
1400	1050	Constant Torque ECM	1	RPM	916	957	1004	1065	[Black]								
				Power (W)	238	248	259	272	[Black]								
				CFM	1186	1152	1113	1056	[Black]								
			2	RPM	1013	1050	1084	1128	1179	1227	1279	1317	1356	1400			
				Power (W)	331	369	352	365	381	396	411	423	437	446			
				CFM	1345	1317	1283	1251	1215	1181	1150	1124	1094	1050			
			3	RPM	1108	1142	1178	1207	1247	1293	1336	1382	1426	1462			
				Power (W)	448	461	474	486	501	518	534	551	568	581			
				CFM	1507	1482	1455	1427	1396	1365	1331	1296	1276	1246			
			4	RPM	1200	1231	1263	1292	1321	1356	1397	1440	1479	1505			
				Power (W)	582	595	609	622	635	651	669	688	706	681			
				CFM	1641	1623	1601	1577	1548	1519	1488	1455	1423	1355			
			5	RPM	[Black]	[Black]	1317	1372	1392	1412	1436	1469	1500	1504			
				Power (W)	[Black]	[Black]	756	775	776	774	772	768	765	679			
				CFM	[Black]	[Black]	1743	1717	1688	1645	1596	1541	1490	1352			
1400	1050	Constant Volume ECM	Minimum CFM	RPM	786	855	920	985	1059	1125	1186	1240	1292	1346			
				Power (W)	154	177	200	224	252	280	306	331	355	383			
				CFM	1050	1050	1050	1050	1050	1050	1050	1050	1050	1050			
			Default CFM	RPM	997	1042	1094	1145	1193	1241	1292	1345	1400	1451			
				Power (W)	334	359	390	421	453	484	517	555	595	636			
				CFM	1400	1400	1400	1400	1400	1400	1400	1400	1400	1400			
			Maximum CFM	RPM	1224	1245	1282	1305	1327	[Black]							
				Power (W)	658	674	703	700	697	[Black]							
				CFM	1750	1750	1750	1750	1750	[Black]							

See ECM control section for details on setting airflow.  
 Airflow is controlled within 5% up to the Max ESP shown with wet coil.  
 Do not select Dehumidification mode if HP CFM is on setting 1.  
 Black areas denote ESP where operation is not recommended.  
 PSC: Units factory shipped on medium speed. Other speeds require field selection.  
 CT ECM: Units factory shipped on Speed Tap 2 for Fan-Only and Speed Tap 3 for Heating/Cooling.  
 All airflow is rated and shown above at the lower voltage if unit is dual voltage rated, e.g. 208V for 208-230V units.  
 Only two speed PSC fan (H & M) available on 575V units.  
 Performance stated is at the rated power supply. Performance may vary as the power supply varies from the rated.  
 All data is shown wet coil with clean 1" filter.  
 All data is ran at 80 °F DB and 67 °F WB.  
 CFM Tolerance is 7%.  
 RPM/Watt Tolerance 10%.

Tranquility® Compact (TC) Series

Rev.: January 25, 2024

Blower Performance Data – TC048

Rated CFM	Min CFM	Motor Type	Motor Speed Setting	External Static Pressure (in. wg)												
					0.1	0.2	0.3	0.4	0.5	0.6	0.7	0.8	0.9	1.0		
1600	1200	PSC	Low	CFM	1644	1606	1568	1492	1378	1264						
			Medium	CFM	1805	1767	1682	1625	1520	1340						
			High	CFM		1881	1815	1710	1596	1416	1216	1216				
1600	1200	PSC - High Static	Low	CFM	1748	1720	1691	1644	1587	1520	1435	1311				
			Medium	CFM	1938	1891	1843	1796	1739	1691	1625	1539	1416	1254		
			High	CFM				1957	1910	1862	1786	1701	1577	1435		
1500	1200	Constant Torque ECM	1	RPM	767	811	848	886	935							
				Power (W)	225	237	247	257	270							
				CFM	1397	1349	1304	1259	1202							
			2	RPM	826	869	905	940	979	1026	1073					
				Power (W)	287	300	312	322	334	349	363					
				CFM	1527	1484	1441	1398	1351	1294	1240					
			3	RPM	881	925	960	993	1027	1064	1108	1150	1214			
				Power (W)	358	374	387	398	410	423	439	454	473			
				CFM	1660	1619	1577	1537	1494	1452	1399	1349	1254			
			4	RPM	959	997	1034	1064	1093	1124	1157	1195	1206			
				Power (W)	474	491	507	521	533	546	560	576	511			
				CFM	1837	1795	1760	1722	1685	1647	1608	1560	1382			
			5	RPM			1078	1113	1145	1174	1200	1213	1200			
				Power (W)			649	667	684	698	714	695	588			
				CFM			1993	1956	1919	1886	1854	1784	1588			
1500	1200	Constant Volume ECM	Minimum CFM	RPM	703	766	827	886	943	998	1051	1102	1150	1196		
				Power (W)	174	205	237	269	302	336	371	407	444	482		
				CFM	1200	1200	1200	1200	1200	1200	1200	1200	1200	1200	1200	
			Default CFM	RPM	833	884	932	986	1043	1089	1137	1191	1242	1293		
				Power (W)	287	329	369	412	455	495	536	578	620	662		
				CFM	1500	1500	1500	1500	1500	1500	1500	1500	1500	1500	1500	1500
			Maximum CFM	RPM	993	1038	1082	1129	1178	1220	1264	1311	1357	1402		
				Power (W)	562	616	669	724	781	832	885	940	994	1048		
				CFM	1900	1900	1900	1900	1900	1900	1900	1900	1900	1900	1900	1900

See ECM control section for details on setting airflow.  
 Airflow is controlled within 5% up to the Max ESP shown with wet coil.  
 Do not select Dehumidification mode if HP CFM is on setting 1.  
 Black areas denote ESP where operation is not recommended.  
 PSC: Units factory shipped on medium speed. Other speeds require field selection.  
 CT ECM: Units factory shipped on Speed Tap 2 for Fan-Only and Speed Tap 3 for Heating/Cooling.  
 All airflow is rated and shown above at the lower voltage if unit is dual voltage rated, e.g. 208V for 208-230V units.  
 Only two speed PSC fan (H & M) available on 575V units.  
 Performance stated is at the rated power supply. Performance may vary as the power supply varies from the rated.  
 All data is shown wet coil with clean 1" filter.  
 All data is ran at 80 °F DB and 67 °F WB.  
 CFM Tolerance is 7%.  
 RPM/Watt Tolerance 10%.

Blower Performance Data – TC060

Rated CFM	Min CFM	Motor Type	Motor Speed Setting	External Static Pressure (in. wg)											
				0.1	0.2	0.3	0.4	0.5	0.6	0.7	0.8	0.9	1.0		
1950	1500	PSC	Low	CFM	1803	1774	1744	1695	1637	1568					
			Medium	CFM	1999	1950	1901	1852	1793	1744	1676	1588			
			High	CFM		1881	1815	1710	1596	1416	1216	1216			
1950	1500	PSC - High Static	Low	CFM	1882	1872	1852	1842	1813	1793	1764	1715	1666	1588	
			Medium	CFM	2107	2097	2038	1999	1980	1940	1891	1842	1460	1715	
			High	CFM	2342	2323	2293	2254	2195	2156	2087	2019	1940	1852	
1950	1500	Constant Torque ECM	1	RPM	768	797	830	863							
				Power (W)	342	354	366	380							
				CFM	1685	1640	1593	1545							
			2	RPM	836	867	895	922	955	989	1020	1048	1081		
				Power (W)	460	476	489	501	518	533	548	561	577		
				CFM	1879	1833	1795	1754	1705	1657	1608	1563	1514		
			3	RPM	923	953	974	1000	1025	1052	1079	1109	1137		
				Power (W)	648	666	678	694	708	724	740	757	773		
				CFM	2113	2069	2039	1998	1963	1925	1885	1840	1795		
			4	RPM	972	994	1020	1041	1066	1090	1114	1144	1170		
				Power (W)	771	785	803	817	832	848	864	883	900		
				CFM	2235	2198	2163	2130	2094	2061	2019	1977	1939		
			5	RPM	1003	1025	1050	1074	1099	1122	1147	1166	1194	1209	
				Power (W)	866	881	899	916	934	951	970	977	973	969	
				CFM	2322	2290	2253	2219	2188	2152	2120	2083	2013	1940	
1950	1500	Constant Volume ECM	Minimum CFM	RPM	705	773	836	894	949	998	1044	1085	1121	1153	
				Power (W)	246	301	354	405	453	500	544	587	627	665	
				CFM	1500	1500	1500	1500	1500	1500	1500	1500	1500	1500	
			Default CFM	RPM	852	899	949	992	1031	1085	1136	1179	1225	1272	
				Power (W)	501	562	629	683	731	804	871	926	986	1047	
				CFM	1950	1950	1950	1950	1950	1950	1950	1950	1950	1950	1950
			Maximum CFM	RPM	995	1020	1044	1069	1094						
				Power (W)	885	896	901	916	937						
				CFM	2200	2200	2200	2200	2200						

See ECM control section for details on setting airflow.  
 Airflow is controlled within 5% up to the Max ESP shown with wet coil.  
 Do not select Dehumidification mode if HP CFM is on setting 1.  
 Black areas denote ESP where operation is not recommended.  
 PSC: Units factory shipped on medium speed. Other speeds require field selection.  
 CT ECM: Units factory shipped on Speed Tap 2 for Fan-Only and Speed Tap 3 for Heating/Cooling.  
 All airflow is rated and shown above at the lower voltage if unit is dual voltage rated, e.g. 208V for 208-230V units.  
 Only two speed PSC fan (H & M) available on 575V units.  
 Performance stated is at the rated power supply. Performance may vary as the power supply varies from the rated.  
 All data is shown wet coil with clean 1" filter.  
 All data is ran at 80 °F DB and 67 °F WB.  
 CFM Tolerance is 7%.  
 RPM/Watt Tolerance 10%.

Tranquility® Compact (TC) Series

Rev.: January 25, 2024

## Constant Volume (CV) ECM

The Intelligent Constant Volume (CV) ECM blower motor provides unmatched functionality that saves installing and service technicians time while also providing increased comfort levels to occupants.

CV ECM's are programed to maintain a constant CFM across a wide range of external static pressures (ESP). This functionality differs from traditional PSC or even Constant Torque (CT) ECM's. With traditional PSC and CT ECM fan motors, as ESP is increased CFM is reduced. To increase or decrease the speed of the fan motor requires a fan motor switch or a technician to wire into a different motor tap. CT ECM's provide increased efficiency over PSC motors but with no additional functionality. With a CV ECM, as changes in ESP occur the fan motor will adjust its speed to deliver the desired CFM (within its operating range). This ensures the system is delivering the airflow and capacity it was designed for.

A major benefit of the CV ECM over other fan motor types its ability to adjust airflow remotely through the iGate® 2 web portal/mobile app or directly at the unit with a communicating diagnostic service tool or thermostat. Airflow levels can be adjusted in increments of 25 CFM from the units minimum and maximum CFM range (see CV ECM configuration table for details). This functionality allows technicians to dial in airflow during start-up and commissioning via an easy to use service tool. During operation occupants may have a desire for airflow adjustments. Reducing CFM can reduce airflow sound levels and increase cooling dehumidification (latent capacity). Technicians can easily make these adjustments without making wiring changes reducing service time with minimal disruption to the occupants.

The fan motor operating modes include:

- First Stage Cooling (Y1 & O)
- Second Stage Cooling (Y1, Y2, & O)
- First Stage Heating (Y1)
- Second Stage Heating (Y1 & Y2)
- Fan (G with no Y1, Y2, or W)

The CV ECM motor includes “soft start” and “ramp down” features. The soft start feature gently increases the motors rpm at blower start up resulting quieter blower start cycles. Likewise, the ramp down feature allows the blower to slowly decrease rpm to a full stop resulting in a quieter end to each blower cycle. The ramp down feature (also known as the heating or cooling “Off Delay”) also has the functionality to be field selected by the technician in the allowable range of 0 to 255 seconds.



Airflow Configuration Screen on Mobile App

## Constant Torque (CT) ECM

### The Constant Torque (CT) ECM blower

**motor** combines high efficient airflow movement with simplistic operation.

The CT ECM is designed to maintain a fixed RPM. The delivered unit airflow will depend on the total static applied on the system (ductwork, grilles, etc.). This is similar to the operation of a PSC motor and differs from the CV ECM motor which will adjust RPM to deliver a constant CFM. Also, like a traditional PSC blower motor, the CT ECM blower motor has 4-5 Speed Taps depending on unit size (see blower tables for details). The blower comes factory wired into two speed taps. To adjust speeds in the field a technician manually changes the electrical connection either at the fan motor or connecting wire harness (varies by size).

The blower offers a “soft start” feature. Soft start gently increases the blower motors rpm resulting in quieter operation during start up cycles. The blower does not include a “ramp down” feature like the CV ECM motor. When the fan call is removed the blower will immediately shut down. If the ramp down feature is required please select a CV ECM blower.

The CT ECM blower is not a communicating component and does not contain the high functionality like the CV ECM blower does. It offers an entry level ECM option for applications seeking high efficiency with simplistic functionality. Constant Volume (CV) and Constant Torque (CT) styles of ECM blower motors are both equally efficient in their operation. The difference between the two motors is in their operational functionality.



## Tranquility® Compact (TC) Series

Rev.: January 25, 2024

### Wiring Diagram Matrix

All current diagrams can be located online at [climatemaster.com](http://climatemaster.com).

Click 'Commercial Professional'.

1. Click 'Products' in the main navigation
2. Select 'Small Packaged Units'
3. Select the TC product series
4. Click the Wire Diagrams tab in the middle of the page
5. Select your voltage and controls

Unit Controller	Fan Motor	Water Side Economizer	208v/1 - 265v/1		208v/3	460v/3	575v/3	
			006-012	015-060	024-060	024-060	041-060	
CXM2	PSC	None	96B0514N11		96B0514N21	96B0514N31		
		WSE	96B0515N11		96B0515N21	96B0515N31		
	CT ECM	None	96B0514N12		96B0514N22	96B0514N32		
		WSE	96B0515N12		96B0515N22	96B0515N32		
DXM2.5	PSC	None	96B0521N11		96B0521N21	96B0521N31		
		WSE	96B0476N11		96B0476N21	96B0476N31		
	CT ECM	None	96B0527N11		96B0527N21	96B0527N31		
		WSE	96B0478N11		96B0478N21	96B0478N31		
	CV ECM	None	96B0523N01	96B0523N11	96B0523N21	96B0523N31		
		WSE	96B0477N01	96B0477N11	96B0477N21	96B0477N31		
Auxiliary WD for MPC			96B0147N14					

## DIP Setting Table

### DIP Setting Table - 99D0061N01

Note: Shade indicates DIP switch location

TC DIGIT 9 = D, B + DXM2.5 WSE TC DIGIT 12 = 1,2,3,4 + DXM2.5 WSE				TC DIGIT 9 = P, S + DXM2.5 WSE + MPC TC DIGIT 12 = 1,2,3,4 + DXM2.5 WSE + MPC			
OFF	ON			OFF	ON		
		1				1	
		2				2	
		3				3	
		4				4	
		5				5	
		6				6	
		7				7	
		8				8	
S1				S2			
OFF	ON			OFF	ON		
		1				1	
		2				2	
		3				3	
		4				4	
		5				5	
		6				6	
		7				7	
		8				8	
S1				S2			

## Tranquility® Compact (TC) Series

Rev.: January 25, 2024

### Controls – CXM2 and DXM2.5



#### **CXM2 Controls**

For detailed controller information, see the CXM2 Application, Operation, and Maintenance (AOM) manual (part # 97B0137N01). To confirm the controller type of your particular unit, refer to digit 9 on the unit model number and the unit nomenclature diagram found on page 3 of this manual.



#### **DXM2.5 Controls**

For detailed controller information, see the DXM2.5 Application, Operation, and Maintenance (AOM) manual (part # 97B0142N01). To confirm the controller type of your particular unit, refer to digit 9 on the unit model number and the unit nomenclature diagram found on page 3 of this manual.

## Operating and Commissioning Limits

### Operating Limits

Environment – Units are designed for indoor installation only. Never install units in areas subject to freezing or where humidity levels could cause cabinet condensation (such as unconditioned spaces subject to 100% outside air).

Power Supply – A voltage variation of +/- 10% of nameplate utilization voltage is acceptable.

Determination of operating limits is dependent primarily upon three factors: 1) return air temperature. 2) water temperature, and 3) ambient temperature. When any one of these factors is at minimum or maximum levels, the other two factors should be at normal levels to ensure proper unit operation. Extreme variations in temperature and humidity and/or corrosive water or air will adversely affect unit performance, reliability, and service life. Consult Table 7 for operating limits.

### Commissioning Limits

Consult Table 8 for the particular model. Starting conditions vary depending upon model and are based upon the following notes:

#### Notes:

1. Conditions in Table 8 are not normal or continuous operating conditions. Minimum/maximum limits are start-up conditions to bring the building space up to occupancy temperatures. Units are not designed to operate under these conditions on a regular basis.
2. Voltage utilization range complies with AHRI Standard 110.

Table 7: Operating Limits

Operating Limits	TC	
	Cooling	Heating
<b>Air Limits</b>		
Min. ambient air, DB	45°F [7°C]	39°F [4°C]
Rated ambient air, DB	80.6°F [27°C]	68°F [20°C]
Max. ambient air, DB	130°F [54.4°C]	85°F [29°C]
Min. entering air, DB/WB	*65/50°F [18/10°C]	45°F [7.2°C]
Rated entering air, DB/WB	80.6/66.2°F [27/19°C]	68°F [20°C]
Max. entering air, DB/WB	95/75°F [35/24°C]	80°F [27°C]
<b>Water Limits</b>		
Min. entering water	30°F [-1°C]	20°F [-6.7°C]
Normal entering water	50-110°F [10-43°C]	30-70°F [-1 to 21°C]
Max. entering water	120°F [49°C]	90°F [32°C]
<b>Normal Water Flow</b>	1.5 to 3.0 gpm/ton [1.6 to 3.2 l/m per kW]	

Table 8: Commissioning Limits

Commissioning Limits	Cooling	Heating
<b>Air Limits</b>		
Min. ambient air, DB	45°F [7°C]	39°F [4°C]
Rated ambient air, DB	80.6°F [27°C]	68°F [20°C]
Max. ambient air, DB	130°F [54.4°C]	85°F [29°C]
Min. entering air, DB/WB	50/45°F [10/7°C]	40°F [4.5°C]
Rated entering air, DB/WB	80.6/66.2°F [27/19°C]	68°F [20°C]
Max. entering air, DB/WB	110/83°F [43/28°C]	80°F [27°C]
<b>Water Limits</b>		
Min. entering water	30°F [-1°C]	20°F [-6.7°C]
Normal entering water	50-110°F [10-43°C]	30-70°F [-1 to 21°C]
Max. entering water	120°F [49°C]	90°F [32°C]
<b>Normal Water Flow</b>	1.5 to 3.0 gpm/ton [1.6 to 3.2 l/m per kW]	

## Tranquility® Compact (TC) Series

Rev.: January 25, 2024

## Piping System Cleaning and Flushing

### Piping System Cleaning and Flushing

Cleaning and flushing the WLHP piping system is the single most important step to ensure proper start-up and continued efficient operation of the system.

Follow the instructions below to properly clean and flush the system:

1. Ensure that electrical power to the unit is disconnected.
2. Install the system with the supply hose connected directly to the return riser valve. Use a single length of flexible hose.
3. Fill the system with water. DO NOT allow system to overflow. Bleed all air from the system. Pressurize and check the system for leaks and repair as appropriate.  
Models with Waterside Economizer also manually open economizer valve and coil air vents (2) to bleed air from coil.
4. Verify that all strainers are in place (ClimateMaster recommends a strainer with a #20 stainless steel wire mesh). Start the pumps, and systematically check each vent to ensure that all air is bled from the system.
5. Verify that make-up water is available. Adjust make-up water as required to replace the air which was bled from the system. Check and adjust the water/air level in the expansion tank.
6. Set the boiler to raise the loop temperature to approximately 86°F [30°C]. Open a drain at the lowest point in the system. Adjust the make-up water replacement rate to equal the rate of bleed.
7. Refill the system and add trisodium phosphate in a proportion of approximately one pound per 150 gallons (.8 kg per 1000 l) of water (or other equivalent approved cleaning agent) Reset the boiler to raise the loop temperature to 100°F [38°C]. Circulate the solution for a minimum of 8 to 24 hours. At the end of this period, shut off the circulating pump and drain the solution. Repeat system cleaning if desired.
8. When the cleaning process is complete, remove the short-circuited hoses. Reconnect the hoses to the proper supply, and return the connections to each of the units. Refill the system and bleed off all air.

9. Test the system pH with litmus paper. The system water should be in the range of pH 6.0 - 8.5 (see table 3). Add chemicals, as appropriate to maintain neutral pH levels.
10. When the system is successfully cleaned, flushed, refilled and bled, check the main system panels, safety cutouts and alarms. Set the controls to properly maintain loop temperatures.

### CAUTION!

**CAUTION!** DO NOT use "Stop Leak" or similar chemical agent in this system. Addition of chemicals of this type to the loop water will foul the heat exchanger and inhibit unit operation.

**Note:** The manufacturer strongly recommends all piping connections, both internal and external to the unit, be pressure tested by an appropriate method prior to any finishing of the interior space or before access to all connections is limited. Test pressure may not exceed the maximum allowable pressure for the unit and all components within the water system. The manufacturer will not be responsible or liable for damages from water leaks due to inadequate or lack of a pressurized leak test, or damages caused by exceeding the maximum pressure rating during installation.

## TC with Waterside Economizer Option

Figure 21:

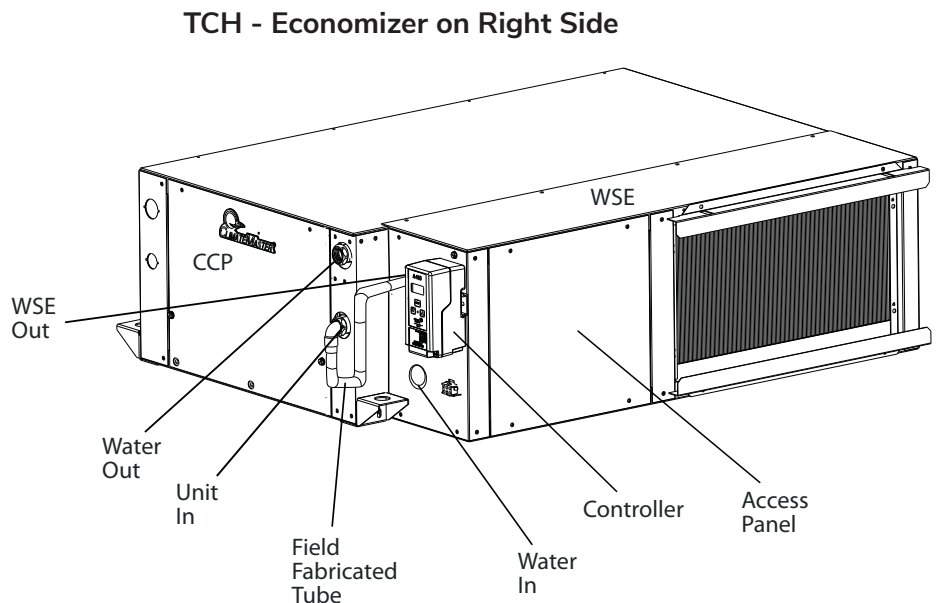
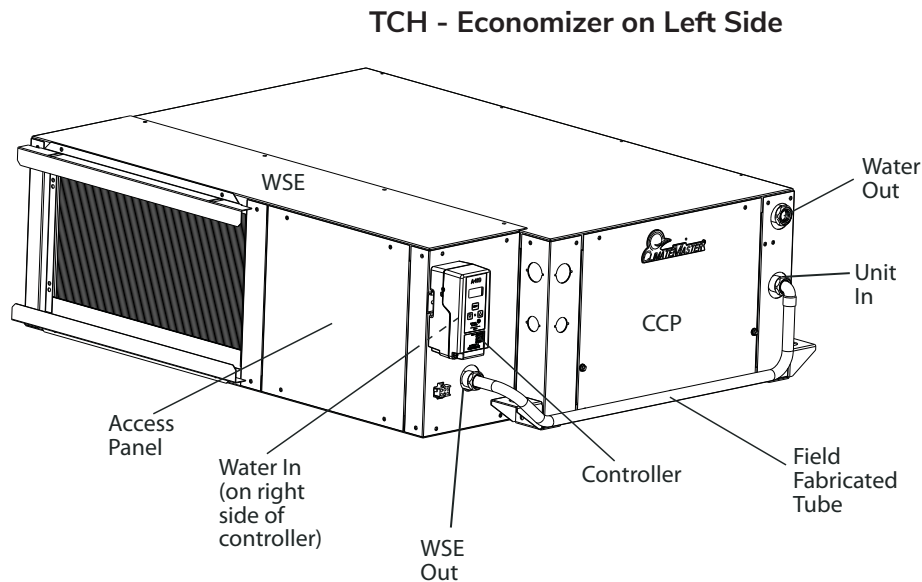

**Notes:**

1. Field to fabricate tube and connect from WSE - OUT to Unit - IN. Do not block compressor/control box service panel (CCP). Hoses are not recommended.
2. Access panel for access to 3 way valve and air bleed vents (2) at top of WSE coil headers. For vertical units and 1 at the top and 1 at the bottom for horizontal units.
3. All units require two external drain traps. The two drains may be connected after the vents.
4. Controllers are shipped inside, remove, slide on DIN rail, and connect molex.

## Tranquility® Compact (TC) Series

Rev.: January 25, 2024

### TC with Waterside Economizer Option, Cont'd.

TCV - Economizer on Left Side

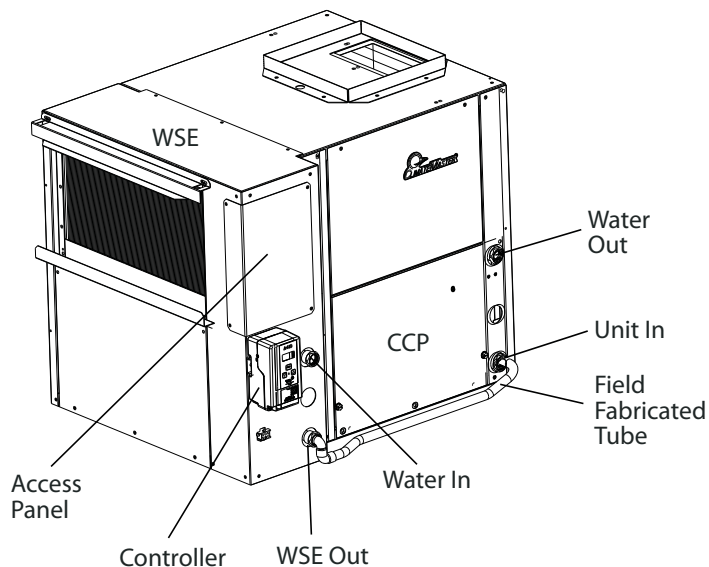

TCV - Economizer on Right Side

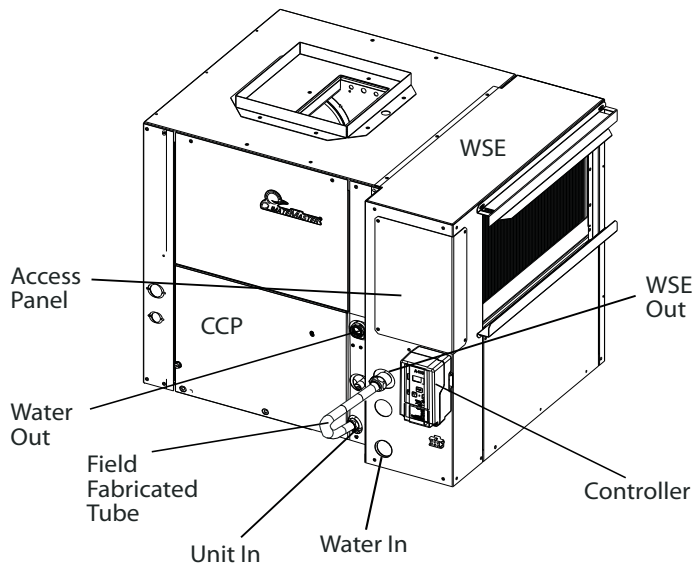

#### Notes:

1. Field to fabricate tube and connect from WSE - OUT to Unit - IN. Do not block compressor/control box service panel (CCP). Hoses are not recommended.
2. Access panel for access to 3 way valve and air bleed vents (2) at top of WSE coil headers. For vertical units and 1 at the top and 1 at the bottom for horizontal units.
3. All units require two external drain traps. Can connect 2 drains after vents.
4. Controllers are shipped inside, remove, slide on DIN rail, and connect molex.

## Unit and System Checkout

### **WARNING!**

**WARNING!** Polyolester Oil, commonly known as POE oil, is a synthetic oil used in many refrigeration systems including those with HFC-410A refrigerant. POE oil, if it ever comes in contact with PVC or CPVC piping, may cause failure of the PVC/CPVC. PVC/CPVC piping should never be used as supply or return water piping with water source heat pump products containing HFC-410A as system failures and property damage may result.

### Unit and System Checkout

BEFORE POWERING SYSTEM, please check the following:

#### UNIT CHECKOUT

- Balancing/shutoff valves: Ensure that all isolation valves are open and water control valves are wired.
- Line voltage and wiring: Verify that voltage is within an acceptable range for the unit and wiring and fuses/breakers are properly sized. Verify that low voltage wiring is complete.
- Unit control transformer: Ensure that transformer has the properly selected voltage tap.
- Entering water and air: Ensure that entering water and air temperatures are within operating limits of Table 8a-b.
- Low water temperature cutout: Verify that low water temperature cut-out on the CXM2/DXM2.5 control is properly set.
- Unit fan: Manually rotate fan to verify free rotation and ensure that blower wheel is secured to the motor shaft. Be sure to remove any shipping supports if needed. DO NOT oil motors upon start-up. Fan motors are pre-oiled at the factory. Check unit fan speed selection and compare to design requirements.
- Condensate line: Verify that condensate line is open and properly pitched toward drain.
- Water flow balancing: Record inlet and outlet water temperatures for each heat pump upon startup. This check can eliminate nuisance trip outs and high velocity water flow that could erode heat exchangers.
- Unit air coil and filters: Ensure that filter is clean and accessible. Clean air coil of all manufacturing oils.
- Unit controls: Verify that CXM2 or DXM2.5 field selection options are properly set.

#### SYSTEM CHECKOUT

- System water temperature: Check water temperature for proper range and also verify heating and cooling set points for proper operation.
- System pH: Check and adjust water pH if necessary to maintain a level between 6 and 8.5. Proper pH promotes longevity of hoses and fittings (see table 3).
- System flushing: Verify that all hoses are connected end to end when flushing to ensure that debris bypasses the unit heat exchanger, water valves and other components. Water used in the system must be potable quality initially and clean of dirt, piping slag, and strong chemical cleaning agents. Verify that all air is purged from the system. Air in the system can cause poor operation or system corrosion.
- Cooling tower/boiler: Check equipment for proper setpoints and operation.
- Standby pumps: Verify that the standby pump is properly installed and in operating condition.
- System controls: Verify that system controls function and operate in the proper sequence.
- Low water temperature cutout: Verify that low water temperature cut-out controls are provided for the outdoor portion of the loop. Otherwise, operating problems may occur.
- System control center: Verify that the control center and alarm panel have appropriate setpoints and are operating as designed.
- Miscellaneous: Note any questionable aspects of the installation.

### **CAUTION!**

**CAUTION!** Verify that ALL water control valves are open and allow water flow prior to engaging the compressor. Freezing of the coax or water lines can permanently damage the heat pump.

### **CAUTION!**

**CAUTION!** To avoid equipment damage, DO NOT leave system filled in a building without heat during the winter unless antifreeze is added to the water loop. Heat exchangers never fully drain by themselves and will freeze unless winterized with antifreeze.

## Tranquility® Compact (TC) Series

Rev.: January 25, 2024

## Unit Start-Up Procedure

## Unit Start-up Procedure

1. Turn the thermostat fan position to "ON". Blower should start.
  2. Balance air flow at registers.
  3. Adjust all valves to their full open positions. Turn on the line power to all heat pumps.
  4. Room temperature should be within the minimum-maximum ranges of table 7. During start-up checks, loop water temperature entering the heat pump should be between 60°F [16°C] and 95°F [35°C].
  5. Two factors determine the operating limits of ClimateMaster heat pumps, (a) return air temperature, and (b) water temperature. When any one of these factors is at a minimum or maximum level, the other factor must be at normal level to ensure proper unit operation.
    - a. Adjust the unit thermostat to the warmest setting. Place the thermostat mode switch in the "COOL" position. Slowly reduce thermostat setting until the compressor activates.
    - b. Check for cool air delivery at the unit grille within a few minutes after the unit has begun to operate.  
**Note: Units have a five minute time delay in the control circuit that can be eliminated on the CXM2/DXM2.5 control board as shown in Figure 22. See controls description for details.**
    - c. Verify that the compressor is on and that the water flow rate is correct by measuring pressure drop through the heat exchanger using the P/T plugs and comparing to table 9.
    - d. Check the elevation and cleanliness of the condensate lines. Dripping may be a sign of a blocked line. Check that the condensate trap is filled to provide a water seal.
    - e. Refer to table 11. Check the temperature of both entering and leaving water. If temperature is within range, proceed with the test. Verify correct water flow by comparing unit pressure drop across the heat exchanger versus the data in table 9. Heat of rejection (HR) can be calculated and compared to submittal data capacity pages. The formula for HR for systems with water is as follows:  

$$HR \text{ (Btuh)} = TD \times GPM \times 500$$
 where TD is the temperature difference between the entering and leaving water, and GPM is the flow rate in U.S. GPM, determined by comparing the pressure drop across the heat exchanger to table 9. In S-I units, the formula is as follows:  $HR \text{ (kW)} = TD \times l/s \times 4.18$ .
    - f. Check air temperature drop across the air coil when compressor is operating. Air temperature drop should be between 15°F and 25°F [8°C and 14°C].
  - g. Turn thermostat to "OFF" position. A hissing noise indicates proper functioning of the reversing valve.
6. Allow five (5) minutes between tests for pressure to equalize before beginning heating test.
    - a. Adjust the thermostat to the lowest setting. Place the thermostat mode switch in the "HEAT" position.
    - b. Slowly raise the thermostat to a higher temperature until the compressor activates.
    - c. Check for warm air delivery within a few minutes after the unit has begun to operate.
    - d. Refer to table 11. Check the temperature of both entering and leaving water. If temperature is within range, proceed with the test. If temperature is outside of the operating range, check refrigerant pressures and compare to table 10. Verify correct water flow by comparing unit pressure drop across the heat exchanger versus the data in table 9. Heat of extraction (HE) can be calculated and compared to submittal data capacity pages. The formula for HE for systems with water is as follows:  

$$HE \text{ (kW)} = TD \times GPM \times 500$$
 where TD is the temperature difference between the entering and leaving water, and l/s is the flow rate in U.S. GPM, determined by comparing the pressure drop across the heat exchanger to tables 10a through 10e. In S-I units, the formula is as follows:  $HE \text{ (kW)} = TD \times l/s \times 4.18$ .
    - e. Check air temperature rise across the air coil when compressor is operating. Air temperature rise should be between 20°F and 30°F [11°C and 17°C].
    - f. Check for vibration, noise, and water leaks.
  7. If unit fails to operate, perform troubleshooting analysis (see troubleshooting section). If the check described fails to reveal the problem and the unit still does not operate, contact a trained service technician to ensure proper diagnosis and repair of the equipment.
  8. When testing is complete, set system to maintain desired comfort level.
  9. BE CERTAIN TO FILL OUT AND FORWARD ALL WARRANTY REGISTRATION PAPERS TO CLIMATEMASTER.

**Note: If performance during any mode appears abnormal, refer to the CXM2/DXM2.5 section or troubleshooting section of this manual. To obtain maximum performance, the air coil should be cleaned before start-up. A 10% solution of dishwasher detergent and water is recommended.**

## Unit Start-Up Procedure, Cont'd.

Figure 22: Test Mode Button

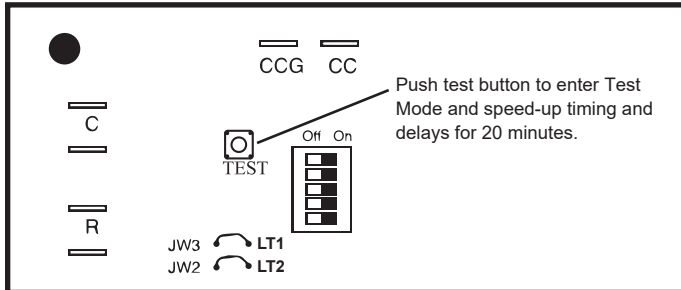

### ! WARNING! !

**WARNING!** When the disconnect switch is closed, high voltage is present in some areas of the electrical panel. Exercise caution when working with energized equipment.

### ! CAUTION! !

**CAUTION!** Verify that ALL water control valves are open and allow water flow prior to engaging the compressor. Freezing of the coax or water lines can permanently damage the heat pump.

### ! CAUTION! !

**CAUTION!** Many units are installed with a factory or field supplied manual or electric shut-off valve. **DAMAGE WILL OCCUR** if shut-off valve is closed during unit operation. A high pressure switch must be installed on the heat pump side of any field provided shut-off valves and connected to the heat pump controls in series with the built-in refrigerant circuit high pressure switch to disable compressor operation if water pressure exceeds pressure switch setting. The field installed high pressure switch shall have a cut-out pressure of 300 psig and a cut-in pressure of 250 psig.

Tranquility® Compact (TC) Series

Rev.: January 25, 2024

## Unit Operating Conditions

Table 9: TC Coax Water Pressure Drop

Model	U.S. GPM	l/s	Pressure Drop, psi [kPa]*			
			30°F [-1°C]	50°F [10°C]	70°F [21°C]	90°F [32°C]
006	0.75	0.05	0.5 [3.7]	0.3 [2.3]	0.2 [1.6]	0.2 [1.6]
	1.1	0.07	0.8 [5.3]	0.5 [3.5]	0.4 [2.7]	0.3 [2.2]
	1.5	0.09	1.3 [8.8]	0.9 [6.1]	0.7 [4.8]	0.6 [4.0]
009	1.1	0.07	1.3 [9.0]	0.6 [4.4]	0.4 [2.8]	0.3 [1.9]
	1.8	0.11	2.1 [14.1]	1.4 [9.4]	1.1 [7.4]	0.9 [6.2]
	2.3	0.14	3.5 [24.3]	2.6 [17.9]	2.1 [14.7]	1.8 [12.7]
012	1.5	0.09	1.9 [12.8]	1.1 [7.6]	0.8 [5.3]	0.6 [4.1]
	2.3	0.15	3.6 [25.0]	2.6 [17.8]	2.1 [14.3]	1.8 [12.1]
	3.0	0.19	6.7 [46.1]	5.0 [34.3]	4.1 [28.3]	3.6 [24.5]
015	1.9	0.12	1.0 [6.9]	0.6 [4.4]	0.5 [3.4]	0.4 [2.8]
	2.8	0.18	1.8 [12.4]	1.4 [9.3]	1.1 [7.6]	1.0 [6.9]
	3.8	0.24	3.3 [22.7]	2.5 [17.5]	2.1 [14.7]	1.9 [13.1]
018	2.3	0.14	2.1 [14.5]	1.4 [9.9]	1.1 [7.6]	0.9 [6.2]
	3.4	0.21	3.4 [23.4]	2.6 [17.6]	2.1 [14.7]	1.8 [12.4]
	4.5	0.28	5.9 [40.6]	4.6 [31.5]	3.9 [26.9]	3.4 [23.4]
024	3.0	0.19	2.2 [15.2]	1.7 [11.6]	1.4 [9.6]	1.2 [8.3]
	4.5	0.28	4.0 [27.6]	3.2 [22.2]	2.8 [19.3]	2.5 [17.2]
	6.0	0.38	7.2 [49.6]	5.9 [40.6]	5.2 [35.8]	4.7 [32.4]
030	3.8	0.24	1.3 [9.0]	0.9 [6.1]	0.7 [4.8]	0.6 [4.1]
	5.6	0.35	2.3 [15.8]	1.8 [12.5]	1.5 [10.3]	1.4 [9.6]
	7.5	0.47	4.2 [28.9]	3.4 [23.2]	2.9 [20]	2.6 [17.9]
036	4.5	0.28	1.8 [12.4]	1.4 [9.6]	1.2 [8.3]	1.0 [6.9]
	6.8	0.43	3.1 [21.4]	2.4 [16.8]	2.1 [14.7]	1.9 [13.1]
	9.0	0.57	5.4 [37.2]	4.4 [30.0]	3.8 [26.2]	3.4 [23.4]
041	5.0	0.32	2.2 [15.0]	1.6 [10.8]	1.1 [7.7]	0.8 [5.6]
	7.5	0.47	4.6 [32.0]	3.5 [24.0]	2.6 [18.01]	2.1 [14.5]
	10.0	0.63	7.7 [53.3]	6.1 [42.1]	5.1 [34.8]	4.6 [31.4]
042	5.3	0.33	2.3 [15.8]	1.8 [12.1]	1.5 [10.3]	1.3 [9.0]
	7.9	0.50	4.3 [29.6]	3.5 [24.2]	3.1 [26.4]	2.8 [19.3]
	10.5	0.66	7.9 [54.4]	6.5 [44.8]	5.7 [39.3]	5.2 [35.8]
048	6.0	.038	1.8 [12.4]	1.5 [10.1]	1.3 [9.0]	1.2 [8.3]
	9.0	0.57	3.4 [23.4]	3.0 [20.4]	2.7 [18.6]	2.6 [17.9]
	12.0	0.76	6.2 [42.7]	5.5 [37.9]	5.1 [35.1]	4.8 [35.1]
060	7.5	0.47	3.4 [23.4]	2.8 [19.2]	2.4 [16.5]	2.2 [15.2]
	11.3	0.71	6.8 [46.9]	5.9 [40.8]	5.4 [37.2]	5.0 [34.5]
	15.0	0.95	12.6 [86.8]	11.1 [76.8]	10.3 [71.0]	9.6 [66.1]

Unit Operating Conditions, Cont'd.

Table 10: TC Series Typical Unit Operating Pressures and Temperatures

006		COOLING						HEATING					
En-tering Water Temp °F	Water Flow GPM/ton	Suction Pressure PSIG	Dis-charge Pressure PSIG	Superheat °F	Subcooling °F	Water Temp Rise °F	Air Temp Drop °F DB	Suction Pressure PSIG	Dis-charge Pressure PSIG	Superheat °F	Subcooling °F	Water Temp Drop °F	Air Temp Rise °F DB
30*	1.5	124-134	159-179	17-22	5-10	18.7-20.7	17-23	71-81	295-315	13-18	5-10	5.9-7.9	17-23
	2.25	120-130	147-167	20-25	5-10	13.6-15.6	18-24	72-82	296-316	14-19	5-10	4.2-6.2	17-23
	3	117-127	136-156	24-29	5-10	8.5-10.5	18-24	74-84	297-317	15-20	5-10	2.5-4.5	17-23
50	1.5	132-142	210-230	7-12	5-10	16.2-18.2	18-24	105-115	330-350	8-13	9-14	8.2-10.2	22-28
	2.25	131-141	199-219	8-13	5-10	11.9-13.9	19-25	110-120	335-355	9-14	9-14	6.1-8.1	22-28
	3	130-140	189-209	9-14	4-9	7.7-9.7	19-25	115-125	339-359	9-14	9-14	4-6	23-29
70	1.5	136-146	275-295	5-10	5-10	15.1-17.1	17-23	136-146	362-382	9-14	10-15	11.3-13.3	27-33
	2.25	136-146	262-282	6-11	4-9	11.1-13.1	18-24	141-151	368-388	9-14	10-15	16.9-18.9	28-34
	3	135-145	250-270	6-11	4-9	7.2-9.2	18-24	147-157	374-394	9-14	10-15	5.6-7.6	29-35
90	1.5	142-152	365-385	5-10	4-9	13.8-15.8	16-22	170-180	402-422	14-19	12-17	14.4-16.4	33-39
	2.25	141-151	353-373	5-10	4-9	10.2-12.2	16-22	173-183	407-427	15-20	12-17	11.1-13.1	33-39
	3	140-150	340-360	5-10	4-9	6.6-8.6	16-22	177-187	412-432	17-22	12-17	7.7-9.1	34-40
110	1.5	148-158	462-482	5-10	4-9	12.5-14.5	14-20						
	2.25	147-157	449-469	5-10	3-8	9.2-11.2	14-20						
	3	146-156	438-458	5-10	3-8	5.9-7.9	14-20						

\*Based on 15% Methanol antifreeze solution

009		COOLING						HEATING					
En-tering Water Temp °F	Water Flow GPM/ton	Suction Pressure PSIG	Dis-charge Pressure PSIG	Superheat °F	Subcooling °F	Water Temp Rise °F	Air Temp Drop °F DB	Suction Pressure PSIG	Dis-charge Pressure PSIG	Superheat °F	Subcooling °F	Water Temp Drop °F	Air Temp Rise °F DB
30*	1.5	113-123	160-180	22-27	13-18	19.5-21.5	17-23	69-79	331-351	11-16	20-25	7.3-9.3	17-23
	2.25	110-120	147-167	25-30	11-16	14.2-16.2	17-23	72-82	335-355	11-16	20-25	5.4-7.4	18-24
	3	108-118	135-155	28-33	9-14	8.9-10.9	16-21	75-85	339-359	11-16	21-26	3.5-5.5	19-25
50	1.5	124-134	211-231	9-14	10-15	18-20	17-23	101-111	360-380	9-14	20-25	9.8-11.8	23-29
	2.25	122-132	199-219	12-17	9-14	13.2-15.2	17-23	105-115	363-383	9-14	19-24	7.4-9.4	24-30
	3	120-130	187-207	15-20	8-13	8.4-10.4	17-23	110-120	366-386	9-14	19-24	4.9-6.9	24-30
70	1.5	129-139	275-295	7-12	8-13	17.4-19.4	16-22	130-140	400-420	10-15	20-25	12.8-14.8	28-34
	2.25	128-138	261-281	8-13	7-12	12.8-14.8	16-22	137-147	407-427	10-15	19-24	9.6-11.6	29-35
	3	127-137	247-267	8-13	6-11	8.2-10.2	16-22	144-154	414-434	10-15	18-23	6.4-8.4	30-36
90	1.5	136-146	364-384	7-12	3-8	15.7-17.7	15-21	170-180	449-469	13-18	17-22	16-18	34-40
	2.25	135-145	350-370	7-12	4-9	11.7-13.7	15-21	178-188	455-475	14-19	15-20	12-14	35-41
	3	134-144	336-356	7-12	4-9	7.6-9.6	15-21	186-196	460-480	15-20	13-18	7.9-9.9	36-42
110	1.5	142-152	467-487	5-10	4-9	13.5-15.5	13-19						
	2.25	141-151	451-471	5-10	4-9	9.9-11.9	13-19						
	3	140-150	435-455	5-10	3-8	6.3-8.3	13-19						

\*Based on 15% Methanol antifreeze solution

012		COOLING						HEATING					
En-tering Water Temp °F	Water Flow GPM/ton	Suction Pressure PSIG	Dis-charge Pressure PSIG	Superheat °F	Subcooling °F	Water Temp Rise °F	Air Temp Drop °F DB	Suction Pressure PSIG	Dis-charge Pressure PSIG	Superheat °F	Subcooling °F	Water Temp Drop °F	Air Temp Rise °F DB
30*	1.5	116-126	155-175	14-19	9-14	19.4-21.4	18-24	70-80	311-331	8-13	8-13	6.9-8.9	18-24
	2.25	113-123	144-164	15-20	8-13	14.3-16.3	18-24	72-82	315-335	8-13	8-13	5.1-7.1	19-25
	3	111-121	132-152	17-22	6-11	9.1-11.1	18-24	75-85	319-339	8-13	8-13	3.2-5.2	19-25
50	1.5	123-133	208-228	8-13	9-14	18.1-20.1	17-23	102-112	354-364	8-13	9-14	9.3-11.3	25-31
	2.25	122-132	196-216	9-14	7-12	13.4-15.4	18-24	106-116	355-375	8-13	9-14	7-9	26-32
	3	121-131	184-204	9-14	5-10	8.6-10.6	18-24	110-120	355-375	8-13	9-14	4.6-6.6	26-32
70	1.5	127-137	266-286	7-12	8-13	17.2-19.2	16-22	131-141	392-412	9-14	8-13	12-14	30-36
	2.25	126-136	255-275	8-13	7-12	12.7-14.7	16-22	137-147	395-415	9-14	8-13	9-11	31-37
	3	126-136	244-264	8-13	5-10	8.2-10.2	16-22	144-154	398-418	9-14	7-12	6-8	32-38
90	1.5	133-143	362-382	6-11	7-12	16-18	15-21	175-185	443-463	10-15	3-8	15-17	36-42
	2.25	132-142	342-362	7-12	5-10	11.8-13.8	15-21	183-193	452-472	11-16	3-8	11.2-13.2	37-43
	3	132-142	331-351	7-12	4-9	7.6-9.6	15-21	190-200	461-491	13-18	3-8	7.4-9.4	38-44
110	1.5	140-150	459-479	6-11	4-9	14.4-16.4	13-19						
	2.25	140-150	441-461	6-11	4-9	10.6-12.6	13-19						
	3	139-149	431-451	6-11	3-8	6.9-8.9	13-19						

\*Based on 15% Methanol antifreeze solution

Tranquility® Compact (TC) Series

Rev.: January 25, 2024

Unit Operating Conditions, Cont'd.

Table 10: TC Series Typical Unit Operating Pressures and Temperatures: Continued

015		COOLING						HEATING					
En-tering Water Temp °F	Water Flow GPM/ton	Suction Pressure PSIG	Dis-charge Pressure PSIG	Superheat °F	Subcooling °F	Water Temp Rise °F	Air Temp Drop °F DB	Suction Pressure PSIG	Dis-charge Pressure PSIG	Superheat °F	Subcooling °F	Water Temp Drop °F	Air Temp Rise °F DB
30*	1.5	116-126	167-187	15-20	9-14	18.3-20.3	18-24	70-80	279-299	6-11	1-5	7-8	16-22
	2.25	116-126	154-174	15-20	7-12	13.9-15.9	19-25	73-83	281-301	7-12	1-5	5.1-7.1	17-23
	3	116-126	140-160	15-20	7-12	9.5-11.5	19-25	75-85	284-304	7-12	1-5	3.3-5.3	17-23
50	1.5	128-138	194-214	11-14	9-14	17.9-19.9	18-24	102-112	312-332	10-15	2-6	9.9-11.9	22-28
	2.25	128-138	180-200	11-14	7-12	13.7-15.7	19-25	106-116	316-336	10-15	2-6	7.4-9.4	23-29
	3	128-138	166-186	11-14	7-12	9.4-11.4	19-25	110-120	321-341	10-15	2-6	4.9-6.9	23-29
70	1.5	136-146	289-309	7-12	9-14	17.4-19.4	17-23	128-138	335-355	12-17	3-8	12.9-14.9	27-34
	2.25	136-146	275-295	7-12	7-12	15.3-17.3	18-24	134-144	340-360	12-17	3-8	9.7-11.7	28-35
	3	136-146	261-281	7-12	6-11	8.8-10.8	18-24	141-151	346-366	12-17	3-8	6.5-8.5	28-35
90	1.5	139-149	386-406	6-11	9-14	16.8-18.8	16-22	160-170	373-393	15-20	3-8	15.8-17.8	30-38
	2.25	139-149	370-390	6-11	7-12	12.5-14.5	16-22	167-177	380-400	16-21	3-8	12-14	31-39
	3	139-149	356-376	6-11	6-11	8.2-9.2	16-22	174-184	388-408	17-22	3-8	8.1-10.1	32-40
110	1.5	145-155	483-503	6-11	9-14	15.8-17.8	15-21						
	2.25	144-154	466-486	6-11	7-12	11.7-13.7	15-21						
	3	143-153	449-469	6-11	6-11	7.5-9.5	15-21						

\*Based on 15% Methanol antifreeze solution

018		COOLING						HEATING					
En-tering Water Temp °F	Water Flow GPM/ton	Suction Pressure PSIG	Dis-charge Pressure PSIG	Superheat °F	Subcooling °F	Water Temp Rise °F	Air Temp Drop °F DB	Suction Pressure PSIG	Dis-charge Pressure PSIG	Superheat °F	Subcooling °F	Water Temp Drop °F	Air Temp Rise °F DB
30*	1.5	122-132	171-191	15-20	14-19	22.5-24.5	20-28	70-80	272-292	4-9	2-6	7.4-9.4	18-24
	2.25	122-132	157-177	15-20	13-18	16.8-19.8	20-28	73-83	275-295	4-9	2-6	5.5-7.5	19-25
	3	122-132	145-165	15-20	13-18	11.2-13.2	20-28	77-87	278-298	4-9	2-6	3.5-5.5	19-25
50	1.5	136-146	198-218	10-15	14-19	22-24	19-25	101-111	302-322	8-13	3-7	10.3-12.3	23-29
	2.25	134-144	183-203	10-15	13-18	16.5-18.5	19-25	105-115	306-326	8-13	3-7	7.9-9.9	24-30
	3	133-143	171-191	11-16	13-18	11-13	19-25	109-119	311-331	8-13	3-7	5.5-7.5	25-31
70	1.5	139-149	293-313	6-10	14-19	19-21	18-24	130-140	329-349	10-15	4-9	13.6-15.6	27-33
	2.25	138-148	280-300	6-10	13-18	14.4-16.4	18-24	137-147	337-357	10-15	4-9	10.4-12.4	29-35
	3	137-147	267-287	7-11	13-18	9.8-11.7	18-24	139-149	342-362	10-15	4-9	7.2-9.2	30-36
90	1.5	142-152	389-409	5-10	17-22	16-18	17-23	160-170	360-380	13-18	5-10	17-19	33-41
	2.25	141-151	376-396	5-10	15-20	12.3-14.3	17-23	169-179	368-388	14-19	5-10	12.9-14.9	35-43
	3	140-150	363-383	5-10	13-18	8.5-10.5	17-23	178-188	376-396	14-19	4-9	8.8-10.8	36-44
110	1.5	148-158	486-506	5-10	17-22	14.9-16.9	16-22						
	2.25	147-157	472-492	5-10	15-20	11.4-13.4	16-22						
	3	146-156	458-478	5-10	13-18	7.8-9.8	16-22						

\*Based on 15% Methanol antifreeze solution

024		COOLING						HEATING					
En-tering Water Temp °F	Water Flow GPM/ton	Suction Pressure PSIG	Dis-charge Pressure PSIG	Superheat °F	Subcooling °F	Water Temp Rise °F	Air Temp Drop °F DB	Suction Pressure PSIG	Dis-charge Pressure PSIG	Superheat °F	Subcooling °F	Water Temp Drop °F	Air Temp Rise °F DB
30*	1.5	121-131	174-194	13-18	6-11	19.3-21.3	20-28	65-75	287-307	4-9	3-8	6.8-8.8	17-23
	2.25	120-130	165-185	13-18	5-10	14.5-16.5	20-28	68-78	290-310	5-10	3-8	5-7	18-24
	3	120-130	155-175	13-18	5-10	9.6-11.6	20-28	71-81	292-312	5-10	3-8	3.2-5.2	18-24
50	1.5	127-137	245-265	8-13	6-11	18.3-20.3	19-27	96-106	318-338	6-11	3-8	9.8-11.8	22-28
	2.25	128-138	231-251	8-13	7-12	13.7-15.7	19-27	101-111	322-342	7-12	3-8	7.2-9.2	23-29
	3	128-138	217-237	8-13	7-12	9.1-11.1	19-27	105-115	327-347	8-13	3-8	4.8-6.8	24-30
70	1.5	130-140	352-372	6-11	8-13	17.5-19.5	18-26	127-137	349-369	9-14	3-8	12.7-14.7	27-34
	2.25	130-140	334-354	6-11	9-14	26.2-28.2	18-26	132-142	353-373	9-14	3-8	9.5-11.5	28-35
	3	130-140	306-326	6-11	9-14	8.7-10.7	18-26	137-147	358-378	10-15	3-8	6.3-8.3	29-36
90	1.5	134-144	439-459	5-10	11-16	16.7-18.7	17-23	159-169	379-399	13-18	3-8	15.6-17.6	32-40
	2.25	133-143	416-436	5-10	12-17	12.5-14.5	17-23	164-174	384-404	14-19	3-8	11.7-13.7	33-41
	3	133-143	394-414	5-10	12-17	8.3-10.3	17-23	170-180	390-410	16-21	3-8	7.8-9.8	34-42
110	1.5	140-150	536-556	4-9	22-27	17.1-19.1	17-23						
	2.25	139-149	512-532	4-9	19-23	12.6-14.6	17-23						
	3	138-148	488-508	4-9	17-22	8-10	17-23						

\*Based on 15% Methanol antifreeze solution

Unit Operating Conditions, Cont'd.

Table 10: TC Series Typical Unit Operating Pressures and Temperatures: Continued

030		COOLING						HEATING					
En-tering Water Temp °F	Water Flow GPM/ton	Suction Pressure PSIG	Dis-charge Pressure PSIG	Superheat °F	Subcooling °F	Water Temp Rise °F	Air Temp Drop °F DB	Suction Pressure PSIG	Dis-charge Pressure PSIG	Superheat °F	Subcooling °F	Water Temp Drop °F	Air Temp Rise °F DB
30*	1.5	113-123	188-208	14-19	14-19	19.5-21.5	18-26	67-77	322-342	8-13	15-20	6.9-8.9	17-25
	2.25	114-124	177-197	14-19	13-18	14.5-16.5	19-27	69-79	324-344	8-13	15-20	5.1-7.1	18-26
	3	114-124	166-186	14-19	13-18	9.5-11.5	19-27	71-81	326-346	8-13	15-20	3.3-5.3	18-26
50	1.5	124-134	248-268	11-16	14-19	18.7-20.7	18-26	95-105	346-366	10-15	15-20	9.8-11.8	23-31
	2.25	124-134	233-253	11-16	13-18	13.9-15.9	19-27	99-109	350-370	10-15	15-20	7.3-9.3	24-32
	3	124-134	218-238	11-16	13-18	9.1-11.1	19-27	103-113	355-375	11-16	15-20	4.8-6.8	25-33
70	1.5	132-142	333-353	9-14	13-18	17.5-19.5	18-26	125-135	376-396	13-18	14-19	12.7-14.7	27-35
	2.25	132-142	313-333	9-14	12-17	13-15	18-26	133-143	386-406	13-18	14-19	9.8-11.8	28-36
	3	132-142	293-313	9-14	12-17	8.5-10.5	18-26	136-146	393-413	13-18	14-19	6.4-8.4	30-38
90	1.5	135-145	431-451	7-12	17-22	16.5-18.5	17-25	155-165	415-435	15-20	13-18	15.6-18.6	33-41
	2.25	135-145	411-431	7-12	15-20	12.3-14.3	17-25	167-177	422-442	16-21	13-18	11.8-13.8	34-42
	3	135-145	391-411	7-12	13-18	8-10	17-25	170-180	430-450	17-22	13-18	7.9-9.9	36-44
110	1.5	140-150	528-548	6-11	17-22	16.2-18.2	16-24						
	2.25	140-150	506-526	7-12	15-20	11.9-13.9	16-24						
	3	139-149	485-505	7-12	13-18	7.6-9.6	16-24						

\*Based on 15% Methanol antifreeze solution

036		COOLING						HEATING					
En-tering Water Temp °F	Water Flow GPM/ton	Suction Pressure PSIG	Dis-charge Pressure PSIG	Superheat °F	Subcooling °F	Water Temp Rise °F	Air Temp Drop °F DB	Suction Pressure PSIG	Dis-charge Pressure PSIG	Superheat °F	Subcooling °F	Water Temp Drop °F	Air Temp Rise °F DB
30*	1.5	113-123	185-205	17-22	9-14	19.5-21.5	18-26	64-74	327-347	4-9	15-20	7.7-9.7	19-27
	2.25	113-123	174-194	17-22	8-13	14.5-16.5	19-27	66-76	331-351	4-9	15-20	5.7-7.7	19-27
	3	113-123	163-183	17-22	8-13	9.6-11.6	19-27	69-79	335-365	4-9	15-20	3.7-5.7	20-28
50	1.5	121-131	249-269	12-17	9-14	19.4-21.4	17-25	91-101	360-380	10-15	15-20	11.2-13.2	25-33
	2.25	120-130	231-251	12-17	8-13	14.4-16.4	18-26	96-106	370-390	9-14	16-21	8.2-10.2	26-34
	3	120-130	214-234	12-17	8-13	9.4-11.4	18-26	102-112	380-400	8-13	16-21	5.2-7.2	27-35
70	1.5	128-138	327-347	9-14	13-18	19.1-21.1	16-24	125-135	402-422	10-15	14-19	14.7-16.7	32-40
	2.25	128-138	304-324	9-14	11-16	14.1-16.1	17-25	132-142	413-433	10-15	14-19	11-13	33-41
	3	127-137	282-302	9-14	10-15	9.1-11.1	17-25	140-150	423-443	10-15	14-19	7.3-9.3	34-42
90	1.5	132-142	416-436	8-13	20-25	18.8-20.8	15-23	158-168	445-465	13-18	12-17	18.1-20.1	37-45
	2.25	132-142	396-416	8-13	18-23	13.9-15.9	16-24	167-177	456-476	13-18	11-16	13.8-15.8	38-46
	3	131-141	376-396	8-13	16-21	8.9-10.9	16-24	177-187	467-487	14-19	11-16	9.4-11.4	40-48
110	1.5	138-148	550-570	8-13	20-25	18.5-20.5	15-23						
	2.25	136-146	525-545	8-13	18-23	13.6-15.6	15-23						
	3	135-145	500-520	8-13	16-21	8.7-10.7	15-23						

\*Based on 15% Methanol antifreeze solution

TCV 041		Cooling						Heating					
Entering Water Temp °F	Water Flow GPM/ton	Suction Pressure PSIG	Discharge Pressure PSIG	Superheat °F	Subcooling °F	Water Temp Drop °F	Air Temp Drop °F DB	Suction Pressure PSIG	Discharge Pressure PSIG	Superheat °F	Subcooling °F	Water Temp Drop °F	Air Temp Rise °F DB
30	1.5	115-125	174-194	12-17	10-15	19.8-21.8	16-24	69-79	323-343	8-11	5-12	7-9	23-25
	2.25	115-125	159-179	12-17	9-14	14.6-16.6	16-24	72-82	327-347	8-11	5-11	5-7	24-26
	3	115-125	144-164	12-17	9-14	9.5-11.5	16-24	74-84	330-350	9-12	5-11	3-6	24-26
50	1.5	122-132	226-246	9-13	12-16	19-22	22-24	107-117	360-380	10-13	5-10	9-12	29-31
	2.25	121-131	206-226	10-14	10-14	13-15	22-24	102-112	366-386	10-13	5-9	6-9	31-33
	3	121-131	196-216	10-14	8-12	9-12	22-24	105-115	370-390	10-13	5-9	4-7	31-33
70	1.5	126-136	302-322	7-11	12-17	19-21	21-23	127-137	398-418	11-14	5-9	12-15	36-38
	2.25	125-135	280-300	7-11	11-15	12-14	21-23	136-146	409-429	11-14	4-8	8-11	37-39
	3	125-135	268-288	8-12	10-14	9-12	21-23	140-150	413-433	11-14	4-8	6-9	38-40
90	1.5	132-142	392-412	6-8	15-18	18-21	19-21	162-172	440-460	12-16	4-7	15-18	42-44
	2.25	131-141	367-387	7-9	12-14	11-14	19-21	173-183	451-471	13-17	4-7	10-13	44-46
	3	131-141	354-374	7-9	11-13	8-11	19-21	178-188	478-498	14-18	4-6	8-11	45-47
100	1.5	135-145	443-463	6-8	16-18	17-20	19-21						
	2.25	134-144	417-437	6-8	13-15	11-14	19-21						
	3	134-144	404-424	7-9	12-14	8-11	19-21						
110	1.5	138-148	499-519	6-8	17-19	17-20	18-20						
	2.25	137-147	472-492	6-8	14-16	11-14	18-20						
	3	137-147	457-477	7-9	12-14	8-11	18-20						

Tranquility® Compact (TC) Series

Rev.: January 25, 2024

Unit Operating Conditions, Cont'd.

Table 10: TC Series Typical Unit Operating Pressures and Temperatures: Continued

042		COOLING						HEATING					
Entering Water Temp °F	Water Flow GPM/ton	Suction Pressure PSIG	Discharge Pressure PSIG	Superheat °F	Subcooling °F	Water Temp Rise °F	Air Temp Drop °F DB	Suction Pressure PSIG	Discharge Pressure PSIG	Superheat °F	Subcooling °F	Water Temp Drop °F	Air Temp Rise °F DB
30*	1.5	115-125	174-194	12-17	10-15	19.8-21.8	16-24	66-76	314-334	6-11	11-16	7.3-9.3	18-26
	2.25	115-125	159-179	12-17	9-14	14.6-16.6	16-24	69-79	318-338	5-10	12-17	5.4-7.4	19-27
	3	115-125	144-164	12-17	9-14	9.5-11.5	16-24	72-82	321-341	4-9	12-17	3.4-5.4	19-27
50	1.5	123-133	233-253	9-14	10-15	19-21	16-24	97-107	354-374	9-14	13-18	10.2-12.2	24-32
	2.25	122-132	219-239	9-14	9-14	14-16	16-24	101-111	360-380	8-13	13-18	7.6-9.6	25-33
	3	122-132	205-225	9-14	9-14	9.1-11.1	16-24	106-116	365-385	6-11	13-18	5-7	26-34
70	1.5	128-138	309-329	6-11	12-17	18.3-20.3	16-24	130-140	394-414	7-12	13-18	13.3-15.3	30-38
	2.25	128-138	290-310	6-11	11-14	13.5-15.5	16-24	136-146	401-421	7-12	13-18	9.9-1.9	31-39
	3	128-138	271-291	6-11	11-14	8.7-10.7	16-24	143-153	409-429	8-13	13-18	6.6-8.6	32-40
90	1.5	133-143	406-426	5-10	14-19	17.6-19.6	16-24	164-174	434-454	10-15	12-17	16.4-18.4	37-45
	2.25	133-143	386-406	5-10	13-18	12.9-14.9	16-24	172-182	443-463	11-16	12-17	12.3-14.3	38-46
	3	132-142	367-387	5-10	13-18	8.3-10.3	16-24	180-190	453-473	11-16	12-17	8.3-10.3	39-47
110	1.5	138-148	505-525	5-10	19-24	16.8-18.8	16-24						
	2.25	138-148	484-504	5-10	16-21	12.4-14.4	16-24						
	3	138-148	463-483	5-10	14-19	7.9-9.9	16-24						

\*Based on 15% Methanol antifreeze solution

048		COOLING						HEATING					
Entering Water Temp °F	Water Flow GPM/ton	Suction Pressure PSIG	Discharge Pressure PSIG	Superheat °F	Subcooling °F	Water Temp Rise °F	Air Temp Drop °F DB	Suction Pressure PSIG	Discharge Pressure PSIG	Superheat °F	Subcooling °F	Water Temp Drop °F	Air Temp Rise °F DB
30*	1.5	119-129	190-210	15-20	10-15	19.3-21.3	18-26	63-73	284-304	5-10	3-8	6.9-8.9	17-25
	2.25	119-129	179-199	15-20	9-14	14.6-16.6	19-27	66-76	288-308	6-10	3-8	5-7	18-26
	3	119-129	158-178	15-20	9-14	9.8-11.8	19-27	69-79	292-312	6-11	3-8	3.1-5.1	18-26
50	1.5	124-134	248-268	10-15	10-15	19-21	18-26	92-102	309-329	8-13	3-8	9.5-11.5	23-31
	2.25	123-133	230-250	10-15	9-14	14.3-16.3	19-27	96-106	313-333	9-14	3-8	7-9	24-32
	3	123-133	213-233	10-15	9-14	9.6-11.6	19-27	100-110	317-337	9-14	3-8	4.6-6.6	24-32
70	1.5	129-139	337-357	8-13	12-17	18.6-20.6	17-25	123-133	339-359	11-16	3-8	12.5-14.5	29-37
	2.25	129-139	328-348	8-13	11-16	14-16	18-26	128-138	344-364	11-16	3-8	9.3-11.3	29-37
	3	129-139	300-320	8-13	11-16	9.4-11.4	18-26	133-143	350-370	12-17	3-8	6.2-8.2	30-38
90	1.5	134-144	426-446	6-11	15-20	18.2-20.2	16-24	153-163	369-389	14-19	1-6	15.4-17.4	33-41
	2.25	134-144	406-426	6-11	15-20	13.7-15.7	17-25	160-170	376-396	15-20	1-6	11.6-13.6	35-43
	3	134-144	386-406	6-11	15-20	9.2-11.2	17-25	167-177	384-404	16-21	1-6	7.8-9.8	36-44
110	1.5	140-150	560-580	4-9	23-28	17.7-19.7	16-24						
	2.25	140-150	536-556	4-9	20-25	13.4-15.4	16-24						
	3	139-149	511-531	4-9	18-22	9-11	16-24						

\*Based on 15% Methanol antifreeze solution

060		COOLING						HEATING					
Entering Water Temp °F	Water Flow GPM/ton	Suction Pressure PSIG	Discharge Pressure PSIG	Superheat °F	Subcooling °F	Water Temp Rise °F	Air Temp Drop °F DB	Suction Pressure PSIG	Discharge Pressure PSIG	Superheat °F	Subcooling °F	Water Temp Drop °F	Air Temp Rise °F DB
30*	1.5	108-118	180-200	16-21	10-15	20.6	19-27	61-71	314-334	6-11	14-19	7.6-9.6	19-27
	2.25	108-118	165-185	16-21	9-14	15.2-17.2	20-28	64-74	317-337	7-12	13-18	5.6-7.6	20-28
	3	108-118	150-170	16-21	9-14	9.7-11.7	20-28	66-76	319-339	7-12	13-18	3.6-5.6	20-28
50	1.5	113-123	206-226	11-14	10-15	19.8-21.8	18-26	90-100	350-370	11-16	14-19	10.5-12.5	25-33
	2.25	113-123	190-210	11-14	9-14	14.5-16.5	19-27	95-105	357-377	11-16	14-19	7.9-9.9	27-35
	3	113-123	173-193	11-14	9-14	9.3-11.3	19-27	99-109	364-384	10-15	14-19	5.2-7.2	28-36
70	1.5	119-129	305-325	9-14	12-17	18.8-20.8	17-25	123-133	391-411	12-17	14-19	13.7-15.7	33-41
	2.25	118-128	287-307	9-14	11-14	13.8-15.8	18-26	129-139	399-419	12-17	14-19	10.3-12.3	34-42
	3	118-128	269-289	9-14	11-14	8.8-10.8	18-26	135-145	407-427	13-18	14-19	6.9-8.9	35-43
90	1.5	124-134	402-422	7-12	14-19	17.8-19.8	16-24	157-167	431-451	13-18	13-18	16.8-18.8	38-46
	2.25	124-134	382-402	7-12	13-18	13.1-15.1	17-25	164-184	440-460	14-19	13-18	12.7-14.7	39-47
	3	123-133	363-383	7-12	13-18	8.3-10.3	17-25	172-182	450-470	16-21	12-17	8.6-10.6	41-49
110	1.5	130-140	500-520	7-12	20-25	17-19	16-24						
	2.25	129-139	479-499	6-11	16-21	12.4-14.4	16-24						
	3	128-138	458-478	5-10	13-18	7.8-9.8	16-24						

\*Based on 15% Methanol antifreeze solution

Table 11: Water Temperature Change Through Heat Exchanger

Water Flow, gpm [l/m]	Rise, Cooling °F, [°C]	Drop, Heating °F, [°C]
For Closed Loop: Ground Source or Closed Loop Systems at 3 gpm per ton [3.2 l/m per kW]	9 - 12 [5 - 6.7]	4 - 8 [2.2 - 4.4]
For Open Loop: Ground Water Systems at 1.5 gpm per ton [1.6 l/m per kW]	20 - 26 [11.1 - 14.4]	10 - 17 [5.6 - 9.4]

## Preventive Maintenance

**Water Coil Maintenance** - (Direct ground water applications only) If the system is installed in an area with a known high mineral content (125 P.P.M. or greater) in the water, it is best to establish a periodic maintenance schedule with the owner so the coil can be checked regularly. Consult the well water applications section of this manual for a more detailed water coil material selection. Should periodic coil cleaning be necessary, use standard coil cleaning procedures, which are compatible with the heat exchanger material and copper water lines. Generally, the more water flowing through the unit, the less chance for scaling. Therefore, 1.5 gpm per ton [1.6 l/m per kW] is recommended as a minimum flow. Minimum flow rate for entering water temperatures below 50°F [10°C] is 2.0 gpm per ton [2.2 l/m per kW].

**Water Coil Maintenance** - (All other water loop applications) Generally water coil maintenance is not needed for closed loop systems. However, if the piping is known to have high dirt or debris content, it is best to establish a periodic maintenance schedule with the owner so the water coil can be checked regularly. Dirty installations are typically the result of deterioration of iron or galvanized piping or components in the system. Open cooling towers requiring heavy chemical treatment and mineral buildup through water use can also contribute to higher maintenance. Should periodic coil cleaning be necessary, use standard coil cleaning procedures, which are compatible with both the heat exchanger material and copper water lines. Generally, the more water flowing through the unit, the less chance for scaling. However, flow rates over 3 gpm per ton (3.9 l/m per kW) can produce water (or debris) velocities that can erode the heat exchanger wall and ultimately produce leaks.

**Filters** - Filters must be clean to obtain maximum performance. Filters should be inspected every month under normal operating conditions and be replaced when necessary. Units should never be operated without a filter.

Washable, high efficiency, electrostatic filters, when dirty, can exhibit a very high pressure drop for the fan motor and reduce air flow, resulting in poor performance. It is especially important to provide consistent washing of these filters (in the opposite direction of the normal air flow) once per month using a high pressure wash similar to those found at self-serve car washes.

**Condensate Drain** - In areas where airborne bacteria may produce a “slimy” substance in the drain pan, it may be necessary to treat the drain pan chemically with an algaecide approximately every three months to minimize the problem. The condensate pan may also need to be cleaned periodically to ensure indoor air quality. The condensate drain can pick up lint and dirt, especially with dirty filters. Inspect the drain twice a year to avoid the possibility of plugging and eventual overflow.

**Compressor** - Conduct annual amperage checks to ensure that amp draw is no more than 10% greater than indicated on the serial plate data.

**Fan Motors** - All units have permanently lubricated fan motors. Fan motors should never be lubricated unless obvious, dry operation is suspected. Periodic maintenance oiling is not recommended, as it will result in dirt accumulating in the excess oil and cause eventual motor failure. Conduct annual dry operation check and amperage check to ensure amp draw is no more than 10% greater than indicated on serial plate data.

**Air Coil** - The air coil must be cleaned to obtain maximum performance. Check once a year under normal operating conditions and, if dirty, brush or vacuum clean. Care must be taken not to damage the aluminum fins while cleaning. CAUTION: Fin edges are sharp.

**Cabinet** - Do not allow water to stay in contact with the cabinet for long periods of time to prevent corrosion of the cabinet sheet metal. Generally, vertical cabinets are set up from the floor a few inches [7 - 8 cm] to prevent water from entering the cabinet. The cabinet can be cleaned using a mild detergent.

**Refrigerant System** - To maintain sealed circuit integrity, do not install service gauges unless unit operation appears abnormal. Reference the operating charts for pressures and temperatures. Verify that air and water flow rates are at proper levels before servicing the refrigerant circuit.

Tranquility® Compact (TC) Series

Rev.: January 25, 2024

Functional Troubleshooting

Fault	Htg	Clg	Possible Cause	Solution
<b>Main power problems</b>	X	X	Green Status LED Off	Check line voltage circuit breaker and disconnect.
				Check for line voltage between L1 and L2 on the contactor.
				Check for 24VAC between R and C on CXM2/DXM2.5.
				Check primary/secondary voltage on transformer.
<b>HP Fault Code 2 High Pressure</b>		X	Reduced or no water flow in cooling	Check pump operation or valve operation/setting. Check water flow adjust to proper flow rate.
		X	Water Temperature out of range in cooling	Bring water temp within design parameters.
	X		Reduced or no airflow in heating	Check for dirty air filter and clean or replace.
				Check fan motor operation and airflow restrictions.
				Dirty Air Coil - construction dust etc.
				Too high of external static? Check static vs blower table.
	X		Air temperature out of range in heating	Bring return air temp within design parameters.
	X	X	Overcharged with refrigerant	Check superheat/subcooling vs typical operating condition table.
X	X	Bad HP Switch	Check switch continuity and operation. Replace.	
<b>LP/LOC Fault Code 3 Low Pressure / Loss of Charge</b>	X	X	Insufficient charge	Check for refrigerant leaks.
	X		Compressor pump down at start-up	Check charge and start-up water flow.
<b>LT1 Fault Code 4 Water coil low temperature limit</b>	X		Reduced or no water flow in heating	Check pump operation or water valve operation/setting.
				Plugged strainer or filter? Clean or replace.
				Check water flow. Adjust to proper flow rate.
	X		Inadequate antifreeze level	Check antifreeze density with hydrometer.
	X		Improper temperature limit setting (30°F vs 10°F [-1°C vs -2°C])	Clip JW3 jumper for antifreeze (10°F [-12°C]) use.
	X		Water Temperature out of range	Bring water temp within design parameters.
X	X	Bad thermistor	Check temp and impedance correlation per chart.	
<b>LT2 Fault Code 5 Air coil low temperature limit</b>		X	Reduced or no airflow in cooling	Check for dirty air filter and clean or replace.
				Check fan motor operation and airflow restrictions.
				Too high of external static? Check static vs blower table.
		X	Air Temperature out of range	Too much cold vent air? Bring entering air temp within design parameters.
		X	Improper temperature limit setting (30°F vs 10°F [-1°C vs -12°C])	Normal airside applications will require 30°F [-1°C] only.
	X	X	Bad thermistor	Check temp and impedance correlation per chart.
<b>Condensate Fault Code 6</b>	X	X	Blocked drain	Check for blockage and clean drain.
	X	X	Improper trap	Check trap dimensions and location ahead of vent.
		X	Poor drainage	Check for piping slope away from unit.
				Check slope of unit toward outlet.
				Poor venting? Check vent location.
		X	Moisture on sensor	Check for moisture shorting to air coil.
	X	X	Plugged air filter	Replace air filter.
X	X	Restricted Return Airflow	Find and eliminate restriction. Increase return duct and/or grille size.	

Table continued on next page.

## Functional Troubleshooting, Cont'd.

Table continued from previous page.

Fault	Htg	Clg	Possible Cause	Solution
<b>Over/Under Voltage Code 7 (Auto resetting)</b>	X	X	Under Voltage	Check power supply and 24VAC voltage before and during operation.
				Check power supply wire size.
	X	X	Over Voltage	Check compressor starting. Need hard start kit?
				Check 24VAC and unit transformer. Tap for correct power supply voltage.
<b>Unit Performance Sentinel Code 8</b>	X		Heating mode LT2>125°F [52°C]	Check for poor airflow or overcharged unit.
		X	Cooling Mode LT1>125°F [52°C] OR LT2< 40°F [4°C]	Check for poor water flow or airflow.
<b>Swapped Thermistor Code 9</b>	X	X	LT1 and LT2 swapped	Reverse position of thermistors
<b>No Fault Code Shown</b>	X	X	No compressor operation	See "Only Fan Operates".
	X	X	Compressor overload	Check and replace, if necessary.
	X	X	Control board	Reset power and check operation.
<b>Unit Short Cycles</b>	X	X	Dirty air filter	Check and clean air filter.
	X	X	Unit in "test mode"	Reset power or wait 20 minutes for auto exit.
	X	X	Unit selection	Unit may be oversized for space. Check sizing for actual load of space.
	X	X	Compressor overload	Check and replace, if necessary.
<b>Only Fan Runs</b>	X	X	Thermostat position	Ensure thermostat set for heating or cooling operation.
	X	X	Unit locked out	Check for lockout codes. Reset power.
	X	X	Compressor Overload	Check compressor overload. Replace if necessary.
	X	X	Thermostat wiring	Check thermostat wiring at heat pump. Jumper Y and R for compressor operation in test mode.
<b>Only Compressor Runs</b>	X	X	Thermostat wiring	Check G wiring at heat pump. Jumper G and R for fan operation.
	X	X		Check thermostat wiring at heat pump. Jumper Y and R for compressor operation in test mode.
	X	X	Fan motor relay	Jumper G and R for fan operation. Check for line voltage across BR contacts.
	X	X		Check fan power enable relay operation (if present).
	X	X	Fan motor	Check for line voltage at motor. Check capacitor.
<b>Unit Doesn't Operate in Cooling</b>		X	Reversing valve	Set for cooling demand and check 24VAC on RV coil and at CXM2/DXM2.5 board.
		X		If RV is stuck, run high pressure up by reducing water flow and while operating engage and disengage RV coil voltage to push valve.
		X	Thermostat setup	Check for 'O' RV setup not 'B'.
		X	Thermostat wiring	Check O wiring at heat pump. Jumper O and R for RV coil 'click'.
		X		Put thermostat in cooling mode. Check 24 VAC on O (check between C and O); check for 24 VAC on W (check between W and C). There should be voltage on O, but not on W. If voltage is present on W, thermostat may be bad or wired incorrectly.

Tranquility® Compact (TC) Series

Rev.: January 25, 2024

Performance Troubleshooting

Symptom	Htg	Clg	Possible Cause	Solution
Insufficient capacity/ Not cooling or heating	X	X	Dirty filter	Replace or clean.
	X		Reduced or no airflow in heating	Check for dirty air filter and clean or replace.
				Check fan motor operation and airflow restrictions.
				Too high of external static? Check static vs blower table.
		X	Reduced or no airflow in cooling	Check for dirty air filter and clean or replace.
				Check fan motor operation and airflow restrictions.
				Too high of external static? Check static vs blower table.
	X	X	Leaky duct work	Check supply and return air temperatures at the unit and at distant duct registers if significantly different, duct leaks are present.
	X	X	Low refrigerant charge	Check superheat and subcooling per chart.
	X	X	Restricted metering device	Check superheat and subcooling per chart. Replace.
		X	Defective reversing valve	Perform RV touch test.
X	X	Thermostat improperly located	Check location and for air drafts behind stat.	
X	X	Unit undersized	Recheck loads & sizing. Check sensible clg. load and heat pump capacity.	
X	X	Scaling in water heat exchanger	Perform scaling check and clean if necessary.	
X	X	Inlet water too hot or too cold	Check load, loop sizing, loop backfill, ground moisture.	
High Head Pressure	X		Reduced or no airflow in heating	Check for dirty air filter and clean or replace.
				Check fan motor operation and air flow restrictions.
				Too high of external static? Check static vs blower table.
		X	Reduced or no water flow in cooling	Check pump operation or valve operation/setting.
	Check water flow. Adjust to proper flow rate.			
		X	Inlet water too hot	Check load, loop sizing, loop backfill, ground moisture.
	X		Air temperature out of range in heating	Bring return air temperature within design parameters.
		X	Scaling in water heat exchanger	Perform scaling check and clean if necessary.
X	X	Unit overcharged	Check superheat and subcooling. Re-weigh in charge.	
X	X	Non-condensables in system	Vacuum system and re-weigh in charge.	
X	X	Restricted metering device	Check superheat and subcooling per chart. Replace.	
Low Suction Pressure	X		Reduced water flow in heating	Check pump operation or water valve operation/setting.
				Plugged strainer or filter? Clean or replace.
				Check water flow. Adjust to proper flow rate.
	X		Water temperature out of range	Bring water temperature within design parameters.
		X	Reduced airflow in cooling	Check for dirty air filter and clean or replace.
				Check fan motor operation and air flow restrictions.
			Too high of external static? Check static vs blower table.	
	X	Air temperature out of range	Too much cold vent air? Bring entering air temperature within design parameters.	
X	X	Insufficient charge	Check for refrigerant leaks.	
Low Discharge Air Temperature in Heating	X		Too high of airflow	Check fan motor speed selection and airflow chart.
	X		Poor performance	See 'Insufficient Capacity'.
High humidity		X	Too high of airflow	Check fan motor speed selection and airflow chart.
		X	Unit oversized	Recheck loads & sizing. Check sensible cooling load and heat pump capacity.

## Start-Up Log Sheet

**Installer:** Complete unit and system checkout and follow unit start-up procedures in the IOM. Use this form to record unit information, temperatures and pressures during start-up. Keep this form for future reference.

**Job Name:** \_\_\_\_\_ **Street Address:** \_\_\_\_\_

**Model Number:** \_\_\_\_\_ **Serial Number:** \_\_\_\_\_

**Unit Location in Building:** \_\_\_\_\_

**Date:** \_\_\_\_\_ **Sales Order No:** \_\_\_\_\_

In order to minimize troubleshooting and costly system failures, complete the following checks and data entries before the system is put into full operation.

Fan Motor	Description	Value
PSC	Speed Tap	
CT ECM	Speed Tap	
CV ECM	CFM Setting	

**Temperatures: F or C**

**Antifreeze:** \_\_\_\_\_ %

**Pressures: PSIG or kPa**

**Type:** \_\_\_\_\_

	Cooling Mode	Heating Mode
Entering Fluid Temperature		
Leaving Fluid Temperature		
Temperature Differential		
Return-Air Temperature	DB	WB DB
Supply-Air Temperature	DB	WB DB
<b>Temperature Differential</b>		
Water Coil Heat Exchanger (Water Pressure IN)		
Water Coil Heat Exchanger (Water Pressure OUT)		
Pressure Differential		
Water Flow GPM		
<b>Compressor</b>		
Amps		
Volts		
Discharge Line Temperature		
<b>Motor</b>		
Amps		
Volts		

Allow unit to run 15 minutes in each mode before taking data.

Note: Never connect refrigerant gauges during startup procedures. Conduct water-side analysis using P/T ports to determine water flow and temperature difference. If water-side analysis shows poor performance, refrigerant troubleshooting may be required. Connect refrigerant gauges as a last resort.

Tranquility® Compact (TC) Series

Rev.: January 25, 2024

Functional Troubleshooting Form

HEATING CYCLE ANALYSIS -

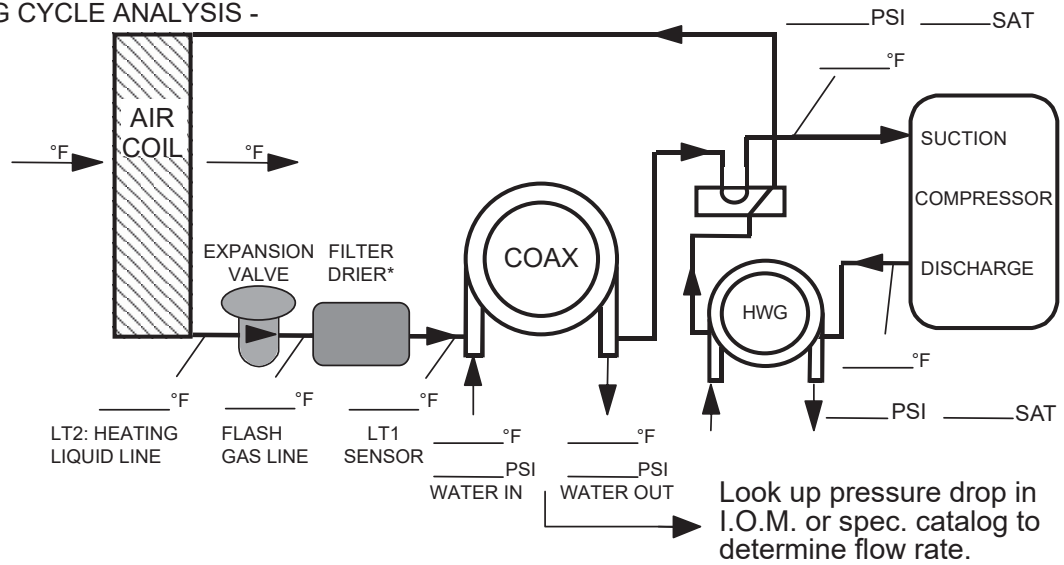

COOLING CYCLE ANALYSIS -

Refrigerant Type:

HFC-410A

Voltage: \_\_\_\_\_

Comp Amps: \_\_\_\_\_

Total Amps: \_\_\_\_\_

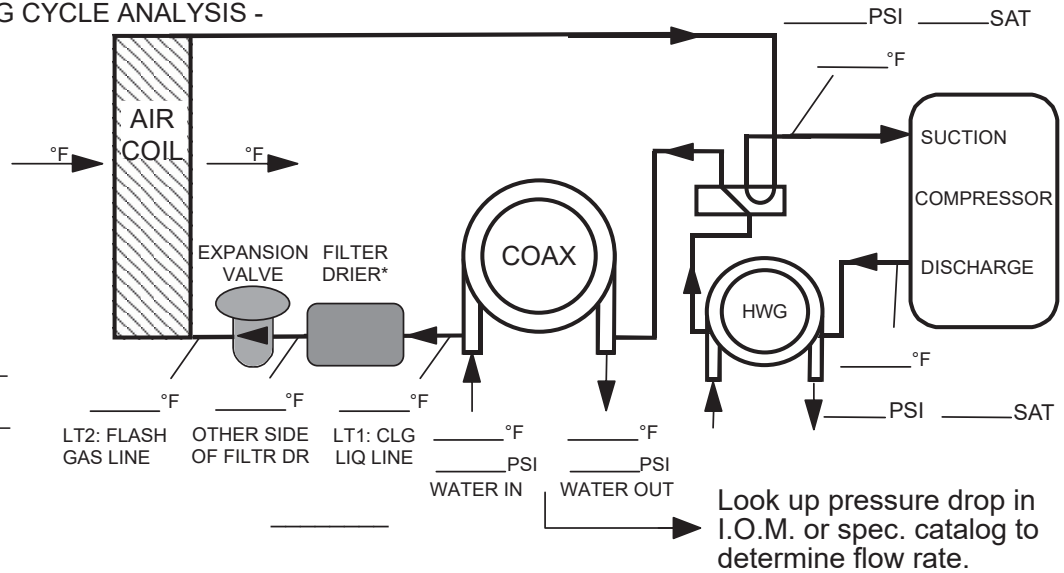

Heat of Extraction (Absorption) or Heat of Rejection =  
 \_\_\_\_\_ flow rate (gpm) x \_\_\_\_\_ temp. diff. (deg. F) x \_\_\_\_\_ fluid factor† = \_\_\_\_\_ (Btu/hr)

Superheat = Suction temperature - suction saturation temp. = \_\_\_\_\_ (deg F)

Subcooling = Discharge saturation temp. - liquid line temp. = \_\_\_\_\_ (deg F)

† Use 500 water for water, 485 for antifreeze.

**NOTE: Never connect refrigerant gauges during startup procedures. Conduct water-side analysis using P/T ports to determine water flow and temperature difference. If water-side analysis shows poor performance, refrigerant troubleshooting may be required. Connect refrigerant gauges as a last resort.**

Warranty (U.S. & Canada)

**CLIMATE MASTER, INC.**

**LIMITED EXPRESS WARRANTY/LIMITATION OF REMEDIES AND LIABILITY**



It is expressly understood that unless a statement is specifically identified as a warranty, statements made by Climate Master, Inc., a Delaware corporation, ("CM") or its representatives, relating to CM's products, whether oral, written or contained in any sales literature, catalog or any other agreement, are not express warranties and do not form a part of the basis of the bargain, but are merely CM's opinion or commendation of CM's products.

**EXCEPT AS SPECIFICALLY SET FORTH HEREIN, THERE IS NO EXPRESS WARRANTY AS TO ANY OF CM'S PRODUCTS. CM MAKES NO WARRANTY AGAINST LATENT DEFECTS. CM MAKES NO WARRANTY OF MERCHANTABILITY OF THE GOODS OR OF THE FITNESS OF ANY PARTICULAR PURPOSE.**

**GRANT OF LIMITED EXPRESS WARRANTY**

CM warrants CM products purchased and retained in the United States of America and Canada to be free from defects in material and workmanship under normal use and maintenance as follows: (1) All complete air conditioning, heating and/or heat pump units built or sold by CM for twelve (12) months from date of unit start up or eighteen (18) months from date of shipment (from factory), whichever comes first; (2) Repair and replacement parts, which are not supplied under warranty, for ninety (90) days from date of shipment (from factory). All parts must be returned to CM's factory in Oklahoma City, Oklahoma, freight prepaid, no later than sixty (60) days after the date of the failure of the part; If CM determines the part to be defective and within CM's Limited Express Warranty, CM shall, when such part has been either replaced or repaired, return such to a factory recognized dealer, contractor or service organization, F.O.B. CM's factory, Oklahoma City, Oklahoma, freight prepaid. The warranty on any parts repaired or replaced under warranty expires at the end of the original warranty period.

This warranty does not cover and does not apply to: (1) Air filters, fuses, refrigerant, fluids, oil; (2) Products relocated after initial installation; (3) Any portion or component of any system that is not supplied by CM, regardless of the cause of the failure of such portion or component; (4) Products on which the unit identification tags or labels have been removed or defaced; (5) Products on which payment to CM has been in default; (6) Products which have defects or damage which result from improper installation, wiring, electrical imbalance characteristics or maintenance; or are caused by accident, misuse or abuse, fire, flood, alteration or misapplication of the product; (7) Products which have defects or damage which result from a contaminated or corrosive air liquid supply, operation at abnormal temperatures, or unauthorized opening of refrigerant circuit; (8) Mold, fungus or bacteria damages; (9) Products subjected to corrosion or abrasion; (10) Products manufactured or supplied by others; (11) Products which have been subjected to misuse, negligence or accidents; (12) Products which have been operated in a manner contrary to CM's printed instructions; or (13) Products which have defects, damage or insufficient performance as a result of insufficient or incorrect system design or the improper application of CM's products.

CM is not responsible for: (1) The costs of any fluids, refrigerant or other system components, or associated labor to repair or replace the same, which is incurred as a result of a defective part covered by CM's Limited Express Warranty; (2) The costs of labor, refrigerant, materials or service incurred in removal of the defective part, or in obtaining and replacing the new or repaired part; or, (3) Transportation costs of the defective part from the installation site to CM or of the return of any part not covered by CM's Limited Express Warranty.

**Limitation:** This Limited Express Warranty is given in lieu of all other warranties. If, notwithstanding the disclaimers contained herein, it is determined that other warranties exist, any such warranties, including without limitation any express warranties or any implied warranties of fitness for particular purpose and merchantability, shall be limited to the duration of the Limited Express Warranty.

**LIMITATION OF REMEDIES**

In the event of a breach of the Limited Express Warranty, CM will only be obligated at CM's option to repair the failed part or unit, or to furnish a new or rebuilt part or unit in exchange for the part or unit which has failed. If after written notice to CM's factory in Oklahoma City, Oklahoma of each defect, malfunction or other failure and a reasonable number of attempts by CM to correct the defect, malfunction or other failure and the remedy fails of its essential purpose, CM shall refund the purchase price paid to CM in exchange for the return of the sold goods(s). Said refund shall be the maximum liability of CM. **THIS REMEDY IS THE SOLE AND EXCLUSIVE REMEDY OF THE BUYER OR THEIR PURCHASER AGAINST CM FOR BREACH OF CONTRACT, FOR THE BREACH OF ANY WARRANTY OR FOR CM'S NEGLIGENCE OR IN STRICT LIABILITY.**

**LIMITATION OF LIABILITY**

CM shall have no liability for any damages if CM's performance is delayed for any reason or is prevented to any extent by any event such as, but not limited to: any war, civil unrest, government restrictions or restraints, strikes or work stoppages, fire, flood, accident, shortages of transportation, fuel, material, or labor, acts of God or any other reason beyond the sole control of CM. **CM EXPRESSLY DISCLAIMS AND EXCLUDES ANY LIABILITY FOR CONSEQUENTIAL OR INCIDENTAL DAMAGE IN CONTRACT, FOR BREACH OF ANY EXPRESS OR IMPLIED WARRANTY, OR IN TORT, WHETHER FOR CM'S NEGLIGENCE OR AS STRICT LIABILITY.**

**OBTAINING WARRANTY PERFORMANCE**

Normally, the contractor or service organization who installed the products will provide warranty performance for the owner. Should the installer be unavailable, contact any CM recognized dealer, contractor or service organization. If assistance is required in obtaining warranty performance, write or call:

Climate Master, Inc. • Customer Service • 7300 S.W. 44th Street • Oklahoma City, Oklahoma 73179 (405) 745-6000

NOTE: Some states or Canadian provinces do not allow limitations on how long an implied warranty lasts, or the limitation or exclusions of consequential or incidental damages, so the foregoing exclusions and limitations may not apply to you. This warranty gives you specific legal rights, and you may also have other rights which vary from state to state and from Canadian province to Canadian province.

Please refer to the CM Installation, Operation and Maintenance Manual for operating and maintenance instructions.



Rev.: 11/09

Tranquility® Compact (TC) Series

Rev.: January 25, 2024

Warranty (International)

**CLIMATE MASTER, INC.**  
**LIMITED EXPRESS WARRANTY /LIMITATION OF REMEDIES AND LIABILITY**  
**(FOR INTERNATIONAL CLASS PRODUCTS)**



This warranty does not cover and does not apply to: (1) Air filters, fuses, refrigerant, fluids, oil; (2) Products relocated after initial installation; (3) Any portion or component of any system that is not supplied by CM, regardless of the cause of the failure of such portion or component; (4) Products on which the unit identification tags or labels have been removed or defaced; (5) Products on which payment by Customer to CM or its distributors or Representatives, or the Customer's seller is in default; (6) Products which have defects or damage which result from improper installation, wiring, electrical imbalance characteristics or maintenance; or from parts or components manufactured by others; or are caused by accident, misuse, negligence, abuse, fire, flood, lightning, alteration or misapplication of the product; (7) Products which have defects or damage which result from a contaminated or corrosive air or liquid supply, operation at abnormal temperatures or flow rates, or unauthorized opening of the refrigerant circuit; (8) Mold, fungus or bacteria damage; (9) Products subjected to corrosion or abrasion; (10) Products, parts or components manufactured or supplied by others; (11) Products which have been subjected to misuse, negligence or accidents; (12) Products which have been operated in a manner contrary to CM's printed instructions; (13) Products which have defects, damage or insufficient performance as a result of insufficient or incorrect system design or the improper application, installation, or use of CM's products; or (14) Electricity or fuel costs, or any increases or unrealized savings in same, for any reason.

CM is not responsible for: (1) The cost of any fluids, refrigerant or other system components, or the associated labor to repair or replace the same, which is incurred as a result of a defective part covered by CM's Limited Express Warranty; (2) The cost of labor, refrigerant, materials or service incurred in diagnosis and removal of the defective part, or in obtaining and replacing the new or repaired part; (3) Transportation costs of the defective part from the installation site to CM or of the return of any part not covered by CM's Limited Express Warranty; or (4) The costs of normal maintenance.

Limitation: This Limited Express Warranty is given in lieu of all other warranties. If, notwithstanding the disclaimers contained herein, it is determined by a court or other qualified judicial body that other warranties exist, any such warranty, including without limitation any express warranty or any implied warranty of fitness for particular purpose and merchantability, shall be limited to the duration of the Limited Express Warranty. This Limited Express Warranty does not exclude any warranty that is mandatory and that may not be excluded under applicable imperative law.

**LIMITATION OF REMEDIES**  
 In the event of a breach of this Limited Express Warranty or any warranty that is mandatory under applicable imperative law, CM will only be obligated at CM's option to either repair the failed part or unit or to furnish a new or rebuilt part or unit in exchange for the part or unit which has failed. If, after written notice to CM's factory in Oklahoma City, Oklahoma, U.S.A. of each defect, malfunction or other failure, and a reasonable number of attempts by CM to correct the defect, malfunction or other failure and the remedy fails of its essential purpose, CM shall refund the purchase price paid to CM in exchange for the return of the sold product(s). Said refund shall be the maximum liability of CM. **TO THE FULLEST EXTENT PERMITTED BY APPLICABLE LAW, THIS REMEDY IS THE SOLE AND EXCLUSIVE REMEDY OF THE CUSTOMER AGAINST CM FOR BREACH OF CONTRACT, FOR THE BREACH OF ANY WARRANTY OR FOR CM'S NEGLIGENCE OR IN STRICT LIABILITY.**

**LIMITATION OF LIABILITY**  
 CM shall have no liability for any damages if CM's performance is delayed for any reason or is prevented to any extent by any event such as, but not limited to: any war, civil unrest, government restrictions or restraints, strikes, or work stoppages, fire, flood, accident, allocations, shortages of transportation, fuel, materials, or labor, acts of God or any other reason beyond the sole control of CM. **TO THE FULLEST EXTENT PERMITTED BY APPLICABLE LAW AND SUBJECT TO THE NEXT SENTENCE, CM EXPRESSLY DISCLAIMS AND EXCLUDES ANY LIABILITY FOR LOSS OF PROFITS, LOSS OF BUSINESS OR GOODWILL, CONSEQUENTIAL, INCIDENTAL, SPECIAL, LIQUIDATED, OR PUNITIVE DAMAGE IN CONTRACT, FOR BREACH OF ANY EXPRESS OR IMPLIED WARRANTY, OR IN TORT, WHETHER FOR CM'S NEGLIGENCE OR AS STRICT LIABILITY.** Nothing in this Agreement is intended to exclude CM's liability for death, personal injury or fraud.

**OBTAINING WARRANTY PERFORMANCE**  
 Normally, the contractor or service organization who installed the products will provide warranty performance for the owner. Should the installer be unavailable, contact any CM recognized Representative. If assistance is required in obtaining warranty performance, write or call:

Climate Master, Inc. • Customer Service • 7300 S.W. 44th Street • Oklahoma City, Oklahoma, U.S.A. 73179 • (405) 745-6000 • FAX (405) 745-6068

NOTE: Some countries do not allow limitations on how long an implied warranty lasts, or the limitation or exclusions of consequential or incidental damages, so the foregoing exclusions and limitations may not apply to you. This warranty gives you specific legal rights, and you may also have other rights which vary from state to state and country to country.

Please refer to the CM Installation, Operation and Maintenance Manual for operating and maintenance instructions.



Created: 10/09

**Notes:**

Tranquility® Compact (TC) Series

Rev.: January 25, 2024

Revision History

Date:	Item:	Action:
1/25/24	Page 10	Updated stainless-steel drain pan verbiage.
1/24/23	Page 33, 39	Updated SBV valve wiring diagram. Added SCCR values to electrical data table.
10/18/22	All	Transitioned from CXM to CXM2 and DXM2 to DXM2.5 unit controls
10/01/21	Page 19-22	Updated Water Quality Requirements table
09/27/21	All	Removed LON option, discontinued
07/08/21	All	Updated to include polymer drain pan
07/07/20	Pgs. 22-23, 27-28 and 52	Added Note 11 and 6, Updated Wiring Diagram Matrix
06/05/20	Page 77	Updated Start-Up Log Sheet
5/20/20	Pgs 20, 21, 24, 25, 26, 29	Added Dimensional Data from Submittal
5/13/20	All	Added CT ECM fan motors; Replaced DXM with DXM2 controls, updated all data tables
10/26/18	Decoder	Added disconnect to controls
8/21/18	Page 31	Updated TC041 rated airflow
11/2/17	Page 58	Added WSE DIP setting table
07/25/17	Page 7	Update hanger and mounting instructions
06/14/17	Page 34	Update drawing
1/30/17	Page 22, 23	Update notes
10/6/16	Page 7	Text Update
10/4/16	WSE right hand Field Fabricated Tube	Corrected
9/27/16	TCH WSE Dim Q	Corrected
9/7/16	Page,24	Updated voltage codes size 041
05/16/16	Table- corrected centimeters in dimensional tables	Updated
04/15/16	Text	Updated
2/24/16	Pages 30, 31	EMC Blower Performance information,
02/06/15	Page 3	Changed E-Coated to Tin-Plated
01/27/16	All	Added WSE Information
01/21/15	All	Added ECM Information



97B0075N07



7300 S.W. 44th Street  
 Oklahoma City, OK 73179  
 Phone: 405-745-6000  
 Fax: 405-745-6058  
 climatemaster.com

ClimateMaster works continually to improve its products. As a result, the design and specifications of each product at the time for order may be changed without notice and may not be as described herein. Please contact ClimateMaster's Customer Service Department at 1-405-745-6000 for specific information on the current design and specifications. Statements and other information contained herein are not express warranties and do not form the basis of any bargain between the parties, but are merely ClimateMaster's opinion or commendation of its products.