



TRANQUILITY® (SM) VERTICAL STACK SERIES

INSTALLATION, OPERATION & MAINTENANCE MANUAL

Part#: 97B0158N01 | Created: March 6, 2024

Models: SM 006-036

60Hz – R-454B



Preliminary

Models:
SM
006-036

Table of Contents

3	Model Nomenclature	48	Electrical: CXM2 Example Wiring Diagram
8	Attentions, Cautions, and Warnings	49	Electrical: Low Voltage Wiring
10	General Information	52	Electrical: Thermostat
13	Refrigerant System Servicing	53	Blower Performance
15	Physical Data	69	Chassis Pre-Installation
16	Pre-Installation Information	70	Hose Kit and Chassis Installation
17	Riser and Cabinet Installation	73	Startup Preparation
25	Leader/Follower Cabinet Installation	75	Controls: CXM2 and DXM2.5
26	Standard (SMS) Cabinet Dimensions	76	Operating Limits and Commissioning Conditions
27	Ducted (SMT) Cabinet Dimensions	78	Unit and System Checkout
28	Standard and Ducted Cabinet Slot Dimensions and Riser Arrangements	79	Unit Startup Procedures
29	80-inch and 88-inch Cabinet Configurations	80	Unit Operating Conditions
30	Supply Grille Installation	84	Coax Water-Pressure Drop
31	Typical Cabinet with L Panel Installation	85	Startup Log Sheet
32	Typical Cabinet with G Panel Installation	86	Preventive Maintenance
33	Typical Cabinet with G Installation – Recessed	87	Functional Troubleshooting
34	Drywall Openings	89	Performance Troubleshooting
36	Cabinet with G Panel Frame	91	Wire Harness
37	Water-Loop Heat-Pump Applications	97	Troubleshooting Form
38	Ground-Loop Heat-Pump Applications	98	Warranty
39	Water Quality Requirements	99	Notes
43	SMS Electrical Data	100	Revision History
47	Electrical: Power Wiring		

ClimateMaster works continually to improve its products. As a result, the design and specifications of each product at the time of order may be changed without notice and may not be as described herein. Please contact ClimateMaster's Customer Service Department at 1-800-299-9747 for specific information on the current design and specifications. Statements and other information contained herein are not express warranties and do not form the basis of any bargain between the parties, but are merely ClimateMaster's opinion or commendation of its products.

Model Nomenclature

1 | 2 | 3 | 4 | 5 | 6 | 7 | 8 | 9 | 10 | 11 | 12 | 13 | 14 | 15
S | **M** | **S** | **S** | **0** | **6** | **A** | **G** | **C** | **0** | **0** | **C** | **3** | **Q** | **S**

PRODUCT NAME

S = R-454B Refrigerant

MODEL TYPE

M = Vertical Stack Chassis Series

CHASSIS STYLE

S = Non-ducted Standard
 T = Ducted Standard

SHIPPING

S = Standard
 M = In Cabinet

SIZE

06 18
 09 24
 12 30
 15 36

REVISION

A = Current

VOLTAGE

60 Hz 1 Phase	Without *RDS	With *RDS
Standard Thermostat		
208/230	G	J
265	E	D
Communicating Thermostat		
208/230	C	K
265	M	L
Standard / RIB Relay		
208/230	S	N
265	R	P
Communicating Thermostat / RIB Relay		
208/230	T	U
265	B	V

*Refrigerant Detection System

CONTROLS

Control	Standard	MPC
CXM2	C	N
DXM2.5	D	P

Use ClimateMaster's selection software at <https://climatemastersolutions.com/eRep/> to configure your Tranquility SM model.

STANDARD

S = Standard

BLOWER MOTOR

L = Constant Volume (CV) EC
 Q = Constant Torque (CT) EC

EXTENDED OPTIONS

3 = Standard range, No UltraQuiet
 4 = Standard range, UltraQuiet
 1 = Extended Range, No UltraQuiet
 2 = Extended Range, UltraQuiet

DRAIN PAN/HEAT EXCHANGER OPTIONS

C = Standard Drain Pan
 S = Standard Stainless Steel Drain Pan

WATER OPTIONS

Option	Description
0	None
7	Internal Secondary Pump
C	Modulating Water Valve
M	Motorized Water Valve Normally Closed (Non-modulating)
R	Motorized Water Valve Normally Open (Non-modulating)
S	Three-way Water Valve (Non-modulating)

REGULATOR OPTIONS

Option	Auto-flow Regulator GPM										
	Unit Size										
	06	09	12	15	18	24	30	36			
0	None										
B	1.0										
C	1.5										
D	2.0										
E		2.5									
F			3.0								
G				3.5							
H					4.0						
J						5.0					
K							6.0				
L								7.0			
M									8.0		
N										9.0	
P											10.5

Models:
SM
006-036

Model Nomenclature

1 | 2 | 3 | 4 | 5 | 6 | 7 | 8 | 9 | 10 | 11 | 12 | 13 | 14 | 15
S | **G** | **3** | **0** | **0** | **6** | **A** | **0** | **4** | **C** | **0** | **0** | **1** | **F** | **S**

PRODUCT NAME

S = R-454B

MODEL TYPE

G = Vertical Stack Cabinet Series

CABINET HEIGHT AND THERMOSTAT WHIP

TSTAT Whip	65" Ducted	80"	88"
None	1	2	3
15'	A	B	C
25'	D	E	F
35'	G	H	J
50'	K	L	M

SHIPPING/PACKAGING

- 0 = Cabinet/chassis separate, no riser, ball-valve assembly optional
- 1 = Cabinet, chassis, and riser shipped separately
- 2 = Cabinet/chassis shipped separately, risers mounted back left
- 3 = Cabinet/chassis shipped separately, risers mounted back right
- 4 = Cabinet/chassis shipped separately, risers mounted left
- 5 = Cabinet/chassis shipped separately, risers mounted right
- 6 = Chassis shipped in cabinet, risers shipped separately
- 7 = Chassis shipped in cabinet, no riser, ball-valve assembly optional

SIZE

- 06 18
- 09 24
- 12 30
- 15 36

REVISION

A = Current

VOLTAGE

Description	208/230-1-60	265-1-60
None	0	N
Disconnect	D	S
Circuit breaker	C	B
Pump	P	M
Disconnect/Pump	W	U
Circuit breaker/Internal Secondary Pump	R	K

CONTROLS AND FAN MOTOR

Motor	Constant Torque	Constant Volume
Surface	5	S
Remote	4	R
ADA	1	B
MPC	2	D

Use ClimateMaster's selection software at <https://climatemastersolutions.com/eRep/> to configure your Tranquility SG model.

SPECIAL OPTIONS

S = Standard

ADDITIONAL CABINET OPTIONS

Open	*Recovered	Return Air	Outside Air	
		Open	With	Without
Yes	Yes	Yes	1	A
		No	2	B
	No	Yes	3	C
		No	4	D
No	No	Yes	5	E
		No	6	F

*Recovered dictates the supply air opening will be knocked out at the factory and a removable dust cover will be added to the opening for dust protection.

FILTERS AND DRAIN PANS

Description	1" Filter	2" Filter
Standard Drain Pan, Standard Seal	1	2
Stainless-steel Drain Pan, Standard Seal	B	H
Standard Drain Pan, Standard Seal, ISO Pad	3	4
Stainless-steel Drain Pan, Standard Seal, ISO Pad	E	L

RISER STYLE AND BALL VALVE OPTION

Riser Style	None	Ball Valve MNPT
Follower/None	0	M
Standard	1	D
Leader	2	R

SIDE SUPPLY AIR OPTIONS

Option	Description
0	None
A	Right Small
B	Right Large
C	Left Small
D	Left Large
E	Right and Left Small
F	Right and Left Large
G	Right Small and Left Large
H	Right Large and Left Small

BACK/FRONT/TOP SUPPLY AIR OPTIONS

Description	Option		
	Cabinet		
	65"	80"	88"
Top	E		
None	0		
Back Small	A		
Back Small and Top	F		
Back Small and Front Small	K		
Back Small and Front Large	M		
Back Small and Front Small/Top	P		
Back Small and Front Large/Top	R		
Back Large	B		
Back Large and Top	G		
Back Large and Front Small	N		
Back Large and Front Large	L		
Back Large and Front Small/Top	S		
Back Large and Front Large/Top	Q		
Front Small	C		
Front Large	D		
Front Small and Top	H		
Front Large and Top	J		

Model Nomenclature

Riser

1 2 3 4 5 6 7 8 9 10 11 12 13 14
2 0 M 3 0 9 8 M 1 2 A S A 0

GROUP

20 = Vertical Stack Riser

M = MAKE ITEM

RISER STYLE

- 1 = 80" cabinet supply/return standard
- 2 = 80" cabinet drain standard
- 3 = 88" and 65" cabinet supply/return standard
- 4 = 88" and 65" cabinet drain standard
- 5 = 80" cabinet supply/return M/S
- 6 = 80" cabinet drain M/S
- 7 = 88" and 65" cabinet supply/return M/S
- 8 = 88" and 65" cabinet drain M/S
- 9 = Riser Extension - Add-on

RISER LENGTH

- 0 = Cabinet/chassis separate, no riser, ball-valve assembly optional
- 1 = Cabinet, chassis, and riser shipped separately
- 2 = Cabinet/chassis shipped separately, risers mounted back left
- 3 = Cabinet/chassis shipped separately, risers mounted back right
- 4 = Cabinet/chassis shipped separately, risers mounted left
- 5 = Cabinet/chassis shipped separately, risers mounted right
- 6 = Chassis shipped in cabinet, risers shipped separately
- 7 = Chassis shipped in cabinet, no riser, ball-valve assembly optional

COPPER TYPE

- M = M Copper
- L = L Copper

RISER TOP DIAMETER

- 0 = Cap
- 1 = 1"
- 2 = 1.25"
- 3 = 1.5"
- 4 = 2"
- 5 = 2.5"
- 6 = 3"

VALVE PACKAGE

- 0 = Drain
- 7 = 06-12 (Sweat Valve)
- 8 = 15-18 (Sweat Valve)
- 9 = 24-36 (Sweat Valve)

REVISION LEVEL

- A = Current Revision Level

SPECIAL

- S = Standard
- A = Special #1
- B = Special #2

TYPE

- A = Standard - Top Swage Only (3" deep)
- B = Standard - Top/Bottom No Swage
- E = Standard - Top Swage Only (3" deep) Insulated
- F = Standard - To/Bottom No Swage Insulated

RISER BOTTOM DIAMETER

- 0 = Cap
- 1 = 1"
- 2 = 1.25"
- 3 = 1.5"
- 4 = 2"
- 5 = 2.5"
- 6 = 3"

Use ClimateMaster's selection software at <https://climatemastersolutions.com/eRep/> to configure your riser selections.

Hose Kit

1 2 3 4 5 6 7 8 9 10
A H U 0 5 0 3 6 S C

GROUP

AH = Accessory Hose Kit

TYPE

HOSE SIZE

- 050 = 1/2" Nominal
- 075 = 3/4" Nominal
- 100 = 1" Nominal

REVISION LEVEL

- C = Current Revision

STANDARD

- S = Standard

LENGTH (INCHES)

Models:
SM
006-036

Model Nomenclature

Return Air Panel G Style

1 2 3 4 5 6 7 8 9 10 11
| A V H S | G | 1 | S | F | S | N | S |

ACCESSORY
VHS RETURN AIR PANEL
SMS/SMT

TYPE G (REMOVABLE)

WIDTH

- 1 = 17"
- 2 = 19"
- 3 = 24"

COLOR

- S = Standard (Polar Ice)
- W = Bright White

INSULATION TYPE

- F = Fiberglass

STANDARD

- S = Standard

REVISION LEVEL

- N = Current Revision SMS/SMT (G Panel)

STYLE

- A = Standard with ADA Type 1 Tstat Option
- B = Standard with ADA Type 2 Tstat Option
- C = Standard with ADA Type 1 Tstat Option and Lock
- D = Standard with ADA Type 2 Tstat Option and Lock
- L = Standard Door with Key Locks
- S = Standard Door

Thermostat Options

Type 1	Type 2
ATP21W02	AVB32V02C
ATA11U03	ATA32V01
AWC99U01	
ATA11U01	
ABV32V03C	

Return Air Panel L Style

1 2 3 4 5 6 7 8 9 10 11 12 13
| A V H R L | 1 | S | F | S | F | O | A | S |

ACCESSORY
VS RETURN AIR PANEL
AVHRL = L-Panel

WIDTH

Option	Width	SMS/SMT
1	17"	06-12
2	19"	15-18
3	24"	24
4	24"	30-36

COLOR

- S = Standard (Polar Ice)
- W = Bright White

INSULATION TYPE

- F = Fiberglass

STANDARD

- S = Standard

REVISION LEVEL

- A = Current Revision

RESERVED FOR FUTURE USE

- O = Standard

COMPONENT

- F = Frame
- P = Panel

STYLE

- S = Standard

Model Nomenclature

Supply Air Grille Nomenclature

1 2 3 4 5 6 7 8 9 10 11 12 13 14
A 8 1 6 G A S S 1 2 0 6 0 A

SUPPLY AIR GRILLE

S = R-454B Refrigerant

GRILLE DEFLECTION

A = Single Deflection
 B = Double Deflection
 C = Double Deflection and Opposed Damper

MATERIAL AND COLOR

SS = Brushed Aluminum
 SP = Painted Aluminum, Polar Ice
 SW = Painted Aluminum, Bright White

REVISION LEVEL

A = Current

SPECIAL OPTIONS

0 = Standard (This option is always 0 unless a special option is quoted from the factory)

DIMENSIONS

*1206 = 12"W x 6"H
 *more dimensions are available on ClimateMaster's selection software site.

Cabinet Stands (ships loose in bulk for field attachment)

1 2 3 4 5 6 7 8 9 10 11 12 13
A C S T 0 0 1 0 0 0 0 0 B

ACCESSORY CABINET STAND

SMS/SMT

CABINET SIZE

0 = 17" x 17" (sizes 06-12)
 1 = 19" x 19" (sizes 15-18)
 2 = 24" x 24" (sizes 24-36)

HEIGHT

01 = 1"	08 = 8"
02 = 2"	09 = 9"
03 = 3"	10 = 10"
04 = 4"	11 = 11"
05 = 5"	12 = 12"
06 = 6"	13 = 13"
07 = 7"	

ISO PAD

0 = Standard (No ISO pad)
 1 = ISO Pad

REVISION

B = Current Version

FUTURE USE

0 = Standard

FUTURE USE

0 = Standard

FUTURE USE

0 = Standard

FUTURE USE

0 = Standard

FUTURE USE

0 = Standard

FUTURE USE

0 = Standard

Models:
SM
006-036

Attentions, Cautions, and Warnings

SAFETY

Warnings, cautions, and notices appear throughout this manual. Read these items carefully before attempting any installation, service, or troubleshooting of the equipment.

DANGER: Indicates an immediate hazardous situation, which if not avoided will result in death or serious injury. DANGER labels on unit access panels must be observed.

WARNING: Indicates a potentially hazardous situation, which if not avoided could result in death or serious injury.

CAUTION: Indicates a potentially hazardous situation or an unsafe practice, which if not avoided could result in minor or moderate injury or product or property damage.

NOTICE: Notification of installation, operation, or maintenance information, which is important, but which is not hazard-related.

WARNING



Disconnect power supply(ies) before servicing. Refer servicing to qualified service personnel. Electric shock hazard. May result in injury or death!

WARNING

To avoid the release of refrigerant into the atmosphere, the refrigerant circuit of this unit must be serviced only by technicians who meet local, state, and federal proficiency requirements.

WARNING

The installation of water-source heat pumps and all associated components, parts, and accessories which make up the installation shall be in accordance with the regulations of ALL authorities having jurisdiction and MUST conform to all applicable codes. It is the responsibility of the installing contractor to determine and comply with ALL applicable codes and regulations.

WARNING

The appliance shall be stored in a room without continuously operating ignition sources (for example: open flames, an operating gas appliance or an operating electric heater).

WARNING

If unit connected via an air duct system to one or more rooms with R-454B is installed in a room with an area less than A_{min} or has an Effective Dispersal Volume less than minimum, that room shall be without continuously operating open flames or other POTENTIAL IGNITION SOURCES. A flame-producing device may be installed in the same space if the device is provided with an effective flame arrest.

WARNING

All refrigerant discharged from this unit must be recovered WITHOUT EXCEPTION. Technicians must follow industry accepted guidelines and all local, state, and federal statutes for the recovery and disposal of refrigerants. If a compressor is removed from this unit, refrigerant circuit oil will remain in the compressor. To avoid leakage of compressor oil, refrigerant lines of the compressor must be sealed after it is removed.

WARNING

This appliance is not intended for use by persons (including children) with reduced physical, sensory, or mental capabilities, or lack of experience and knowledge, unless they have been given supervision or instruction concerning use of the appliance by a person responsible for their safety.

WARNING

An unventilated area where the appliance using FLAMMABLE REFRIGERANTS is installed shall be so constructed that should any refrigerant leak, it will not stagnate so as to create a fire or explosion hazard.

WARNING

Auxiliary devices which may be a POTENTIAL IGNITION SOURCE shall not be installed in the duct work. Examples of such POTENTIAL IGNITION SOURCES are hot surfaces with a temperature exceeding 1,292°F (700°C)

WARNING

An unventilated area where a water source heat pump is installed and surpasses a R-454B refrigerant charge of 62 oz (1.76 kg), shall be without continuously operating open flames (for example an operating gas appliance) or other POTENTIAL IGNITION SOURCES (for example, an operating electric heater, hot surfaces).

WARNING

Only auxiliary electric heaters approved by ClimateMaster shall be installed in connecting ductwork. The installation of any other auxiliary devices is beyond ClimateMaster's responsibility.

WARNING

For mechanical ventilation, the lower edge of the air extraction opening where air is exhausted from the room shall not be more than 3.94 inches (100 mm) above the floor. The location where the mechanical ventilation air extracted from the space is discharged shall be separated by a sufficient distance, but not less than 9.84 feet (3 m), from mechanical ventilation air intake openings, to prevent recirculation to the space.

WARNING

Children being supervised are NOT to play with the appliance.

WARNING

Do not pierce or burn.

WARNING

Be aware that refrigerants may not contain odor.

Attentions, Cautions, and Warnings

CAUTION

DO NOT store or install units in corrosive environments or in locations subject to temperature or humidity extremes (e.g., attics, garages, rooftops, etc.). Corrosive conditions and high temperature or humidity can significantly reduce performance, reliability, and service life. Always move and store units in an upright position. Tilting units on their sides will cause equipment damage.

CAUTION

CUT HAZARD - Failure to follow this caution may result in personal injury. Sheet metal parts may have sharp edges or burrs. Use care and wear appropriate protective clothing, safety glasses and gloves when handling parts and servicing heat pumps.

CAUTION

To avoid equipment damage, DO NOT use these units as a source of heating or cooling during the construction process. The mechanical components and filters can quickly become clogged with construction dirt and debris, which may cause system damage and void product warranty.

CAUTION

All three phase scroll compressors must have direction of rotation verified at startup. Verification is achieved by checking compressor Amp draw. Amp draw will be substantially lower compared to nameplate values. Additionally, reverse rotation results in an elevated sound level compared to correct rotation. Reverse rotation will result in compressor internal overload trip within several minutes. Verify compressor type before proceeding.

NOTICE

Servicing shall be performed only as recommended by the manufacturer.

NOTICE

REFRIGERANT SENSORS for REFRIGERANT DETECTION SYSTEMS shall only be replaced with sensors specified by the appliance manufacturer.

General Information

INSPECTION

Upon receipt of the equipment, carefully check the shipment against the bill of lading. Make sure all units have been received. Inspect the packaging of each unit, and inspect each unit for damage. Ensure that the carrier makes proper notation of any shortages or damage on all copies of the freight bill and completes a common carrier inspection report. Concealed damage not discovered during unloading must be reported to the carrier within 15 days of receipt of shipment. If not filed within 15 days, the freight company can deny the claim without recourse.

NOTE: It is the responsibility of the purchaser to file all necessary claims with the carrier. Notify your equipment supplier of all damage within 15 days of shipment.

STORAGE

Equipment should be stored in its original packaging in a clean, dry area. Store units in an upright position at all times.

UNIT PROTECTION

Cover units on the job site with either the original packaging or an equivalent protective covering. Cap the open ends of pipes stored on the job site. In areas where painting, plastering, and/or spraying has not been completed, all due precautions must be taken to avoid physical damage to the units and contamination by foreign material. Physical damage and contamination may prevent proper startup and may result in costly equipment clean-up.

Examine all pipes, fittings, and valves before installing any of the system components. Remove any dirt or debris found in or on these components.

PRE-INSTALLATION

Installation, Operation, and Maintenance instructions are provided with each unit. The installation site chosen should include adequate service clearance around the unit. Before unit startup, read all manuals and become familiar with the unit and its operation. Thoroughly check the system before operation.

PREPARE UNITS FOR INSTALLATION AS FOLLOWS:

1. Compare the electrical data on the unit nameplate with ordering and shipping information to verify that the correct unit has been shipped.
2. Keep the cabinet covered with the original packaging until installation is complete and all plastering, painting, etc. is finished.
3. Verify refrigerant tubing is free of kinks or dents and that it does not touch other unit components.
4. Inspect all electrical connections. Connections must be clean and tight at the terminals.
5. Remove any blower support packaging (water-to-air units only).
6. Locate and verify any accessory kit located in the chassis compressor section or cabinet blower section.

CHECKS TO THE AREA

Prior to beginning work on systems containing FLAMMABLE REFRIGERANTS, safety checks are necessary to ensure that the risk of ignition is minimized. For repair to the REFRIGERATING SYSTEM, these steps shall be completed prior to conducting work on the system.

General Information

Work Procedure

Work shall be undertaken following a controlled procedure so as to minimize the risk of a flammable gas or vapor being present while the work is being performed.

General Work Area

All maintenance staff and others working in the local area shall be instructed on the nature of work being carried out. Work in confined spaces shall be avoided.

Checking for presence of refrigerant

The area shall be checked with an appropriate refrigerant detector prior to and during work, to ensure the technician is aware of potentially toxic or flammable atmospheres. Ensure that the leak detection equipment being used is suitable for use with all applicable refrigerants, i.e. non-sparking, adequately sealed or intrinsically safe.

Presence of fire Extinguisher

If any hot work is to be conducted on the refrigeration equipment or any associated parts, appropriate fire extinguishing equipment shall be available to hand. Have a dry powder or CO₂ fire extinguisher adjacent to the charging area.

No ignition sources

No person carrying out work in relation to a REFRIGERATION SYSTEM which involves exposing any pipe work shall use any sources of ignition in such a manner that it may lead to the risk of fire or explosion. All possible ignition sources, including cigarette smoking, should be kept sufficiently far away from the site of installation, repairing, removing and disposal, during which refrigerant can possibly be released to the surrounding space. Prior to work taking place, the area around the equipment is to be surveyed to make sure that there are no flammable hazards or ignition risks. "No Smoking" signs shall be displayed.

Ventilated area

Ensure that the area is in the open or that it is adequately ventilated before breaking into the system or conducting any hot work. A degree of ventilation shall continue during the period that the work is carried out. The ventilation should safely disperse any released refrigerant and preferably expel it externally into the atmosphere.

Checks to the Refrigeration Equipment

The following checks shall be applied to installations using FLAMMABLE REFRIGERANTS:

- The actual REFRIGERANT CHARGE is in accordance with the room size within which the refrigerant containing parts are installed;
- The ventilation machinery and outlets are operating adequately and are not obstructed;
- If an indirect refrigerating circuit is being used, the secondary circuit shall be checked for the presence of refrigerant;
- Marking to the equipment continues to be visible and legible. Markings and signs that are illegible shall be corrected;
- Refrigerant piping or components are installed in a position where they are unlikely to be exposed to any substance which may corrode refrigerant containing components, unless the components are constructed of materials which are inherently resistant to being corroded or are suitably protected against being so corroded.

Checks to Electrical Devices

Repair and maintenance to electrical components shall include initial safety checks and component inspection procedures. If a fault exists that could compromise safety, then no electrical supply shall be connected to the circuit until it is satisfactorily dealt with. If the fault cannot be corrected immediately but it is necessary to continue operation, an adequate temporary solution shall be used. This shall be reported to the owner of the equipment so all parties are advised.

Initial safety checks shall include:

- Capacitors are discharged: this shall be done in a safe manner to avoid possibility of sparking;
- That no live electrical components and wiring are exposed while charging, recovering, or purging the system;
- That there is continuity of earth bonding.

Models:
SM
006-036

General Information

REPAIR TO INTRINSICALLY SAFE COMPONENTS

Intrinsically safe components must be replaced.

CABLING

Check that cabling will not be subject to wear, corrosion, excessive pressure, vibration, sharp edges or any other adverse environmental effects. The check shall also take into account the effects of aging or continual vibration from sources such as compressors or fans.

REQUIRED AREA FOR INSTALLATION

The minimum room area of the space (A_{min}) or a minimum room area of conditioned space (T_{amin}) shall be corrected for unit's location altitude by multiplying A_{min} or T_{amin} by the applicable altitude adjustment factor (AF) for building ground-level altitude (H_{alt}) in feet or meters, as shown in Table 1 below.

NOTE: You can use Imperial or Metric measurements to calculate A_{min} or T_{amin} .

Table 1: Altitude Adjustment

H_{alt} ft (m)	AF
0 (0)	1.00
656 (200)	1.00
1,312 (400)	1.00
1,968 (600)	1.00
2,624 (800)	1.02
3,280 (1,000)	1.05
3,937 (1,200)	1.07
4,593 (1,400)	1.10
5,249 (1,600)	1.12
5,905 (1,800)	1.15
6,561 (2,000)	1.18
7,217 (2,200)	1.21
7,874 (2,400)	1.25
8,530 (2,600)	1.28
9,186 (2,800)	1.32
9,842 (3,000)	1.36
10,498 (3,200)	1.40

Refrigerant System Servicing

REFRIGERANT SYSTEM

To maintain sealed circuit integrity, do not install service gauges unless unit operation appears abnormal. Reference the operating charts for pressures and temperatures. Verify that air and water flow rates are at proper levels before servicing the refrigerant circuit.

Removal and Evacuation

When breaking into the refrigerant circuit to make repairs - or for any other purpose - conventional procedures shall be used. However, for flammable refrigerants it is important that best practice be followed, since flammability is a consideration. The following procedure shall be adhered to:

- Safely remove refrigerant following local and national regulations
- Evacuate
- Purge the circuit with Inert gas
- Evacuate
- Continuously flush or purge with Inert gas when using flame to open circuit
- Open the circuit.

The refrigerant charge shall be recovered into the correct recovery cylinders if venting is not allowed by local and national codes. For appliances containing flammable refrigerants, the system shall be purged with oxygen-free nitrogen to render the appliance safe for flammable refrigerants. This process might need to be repeated several times. Compressed air or oxygen shall not be used for purging refrigerant systems.

For appliances containing flammable refrigerants, refrigerant purging shall be achieved by breaking the vacuum in the system with oxygen-free nitrogen and continuing to fill until the working pressure is achieved, then venting to atmosphere, and finally pulling down to a vacuum (optional for FLAMMABLE REFRIGERANT). This process shall be repeated until no refrigerant remains in the system (optional for FLAMMABLE REFRIGERANT). When the final oxygen-free nitrogen charge is used, the system shall be vented down to atmospheric pressure to enable work to take place.

The outlet for the vacuum pump shall not be close to any potential ignition sources, and ventilation shall be available.

Charging Procedures

In addition to conventional charging procedures, the following requirements shall be followed:

- Ensure that contamination of different refrigerants does not occur when using charging equipment.
- Hoses or lines shall be as short as possible to minimize the amount of refrigerant contained in them.
- Cylinders shall be kept in an appropriate position according to the instructions.
- Ensure that the REFRIGERATION SYSTEM is earthed prior to charging the system with refrigerant.
- Label the system when charging is complete (if not already).
- Extreme care shall be taken not to overfill the REFRIGERATION SYSTEM.

Prior to recharging the system, it shall be pressure-tested with the appropriate purging gas. The system shall be leak-tested on completion of charging but prior to commissioning. A follow up leak test shall be carried out prior to leaving the site.

Leak Detection

Under no circumstances shall potential sources of ignition be used in the searching for or detection of refrigerant leaks. A halide torch (or any other detector using a naked flame) shall not be used.

The following leak detection methods are deemed acceptable for all refrigerant systems.

Electronic leak detectors may be used to detect refrigerant leaks but, in the case of FLAMMABLE REFRIGERANTS, the sensitivity may not be adequate, or may need re-calibration. (Detection equipment shall be calibrated in a refrigerant-free area.) Ensure that the detector is not a potential source of Ignition and is suitable for the refrigerant used.

Models:
SM
006-036

Refrigerant System Servicing

Leak detection equipment shall be set at a percentage of the lower flammability limit of the refrigerant and shall be calibrated to the refrigerant employed, and the appropriate percentage of gas (25% maximum) is confirmed.

Leak detection fluids are also suitable for use with most refrigerants but the use of detergents containing chlorine shall be avoided as the chlorine may react with the refrigerant and corrode the copper pipe-work.

NOTE:

Examples of leak detection fluids are:

- Bubble method
- Fluorescent method agents

If a leak is suspected, all naked flames shall be removed/extinguished.

If a refrigerant leak that requires brazing is identified, all of the refrigerant shall be recovered from the system, or isolated (by means of shut off valves) in a part of the system remote from the leak. Removal of refrigerant shall be according to Removal and Evacuation section.

Physical Data

Models:
SM
006-036

Tranquility Non-Ducted SMS Series

SM Series	06	09	12	15	18	24	30	36
Compressor (1 Each)	Rotary					Scroll		
Factory Charge HFC-410A (oz) [kg]	28 [0.79]*	30 [0.85]*	30 [0.85]*	34 [0.96]*	42 [1.19]*	57 [1.62]*	56 [1.59]*	56 [1.59]
Chassis Air Coil								
Coax Volume (Gallons) [Liters]	0.26 [.98]			0.36 [1.4]		0.60 [2.3]		
Hose Size (in)	1/2			3/4		1		
Weight								
Chassis - (lbs) [kg]	110 [50]*	110 [50]	117 [53]	123 [56]	125 [57]	186 [84]	190 [86]	192 [87]
80" Cabinet - (lbs) [kg]	114 [52]			133 [60]		170 [77]		
88" Cabinet - (lbs) [kg]	128 [58]			148 [67]		185 [84]		

Tranquility Ducted SMT Series

SM Series	06	09	12	15	18	24	30	36
Compressor (1 Each)	Rotary					Scroll		
Factory Charge HFC-410A (oz) [kg]	28 [0.79]*	30 [0.85]*	30 [0.85]*	34 [0.96]*	42 [1.19]*	57 [1.62]*	52 [1.59]*	56 [1.59]*
Chassis Air Coil								
Return Air Filter Dimensions (h x w) - (in) [mm]	30 x 14 [762 x 356]			30 x 16 [762 x 406]		32 x 20 [813 x 508]		
Coax Volume (Gallons) [Liters]	0.26 [.98]			0.36 [1.4]		0.60 [2.3]		
Hose Size (in)	1/2			3/4		1		
Weight								
Chassis - (lbs) [kg]	110 [50]*	110 [50]	117 [53]	123 [56]	125 [57]	186 [84]	190 [86]	192 [87]
65" Cabinet - (lbs) [kg]	95 [43]			108 [49]		142 [64]		

CAUTION

DO NOT store or install units in corrosive environments or in locations subject to temperature or humidity extremes (e.g., attics, garages, rooftops, etc.). Corrosive conditions and high temperature or humidity can significantly reduce performance, reliability, and service life. Always move and store units in an upright position. Tilting units on their sides will cause equipment damage.

CAUTION

CUT HAZARD - Failure to follow this caution may result in personal injury. Sheet metal parts may have sharp edges or burrs. Use care and wear appropriate protective clothing, safety glasses and gloves when handling parts and servicing heat pumps.

Pre-Installation Information

STORAGE

Equipment should be stored in its original packaging in a clean, dry area. Store chassis in an upright position at all times. Stack units at a maximum of two-units high.

Store cabinets how they were shipped - horizontal or vertical, keeping them on their pallets for protection. Do not stack multi-packs. Stack cabinets with risers a maximum of two high.

UNIT PROTECTION

Cover units on the job site with either the original packaging or an equivalent protective covering. Cap the open ends of pipes stored on the job site. In areas where painting, plastering, and/or spraying is not complete, take all due precautions to avoid physical damage to the units and contamination by foreign material. Cover all openings in cabinet during all stages of construction. Physical damage and contamination may prevent proper startup and may result in costly equipment cleanup.

Examine all pipes, fittings, and valves before installing any of the system components. Remove any dirt or debris found in or on these components.

Prior to flushing risers with water, ensure that the temperature in building is always be above freezing.

PRE-INSTALLATION

Installation, Operation, and Maintenance instructions are provided with each unit. The installation site chosen should include adequate service clearance around the unit. Before unit installation and startup, read all manuals and become familiar with the unit and its operation. Thoroughly check the system before operation. Your installation may require additional, different sequence, or modification to steps in this IOM.

Prepare cabinet for installation as follows:

- Compare the electrical data on the unit nameplate with ordering and shipping information to verify that the correct unit was shipped.
- Each cabinet has labeling that indicates the location where it is to be installed and the riser diameters if they are attached.
- Keep the cabinet openings and exposed sheet metal covered until installation is complete and all plastering, painting, etc. is finished and cleaned.
- Inspect all electrical connections. Connections must be clean and tight at the terminals.
- If not ordered with factory configuration option, configure supply air openings - remove knockouts (K.O.), cut insulation, and assemble duct angles. Check to see if supply air openings (size and location) are correct with building plans. Do not remove extra K.O.'s. You must securely cover any open, unused K.O.'s.
- For cabinets without risers - remove correct riser knockouts, slit insulation vertically down the center of slot (do not remove).
- Repair any torn insulation with foil tape.
- A base vibration dampening pad is recommended to help eliminate transfer of vibration to the structure. If isolation pad was not ordered, obtain a 0.070-inch to 0.125-inch (1.5 to 3 mm) thick pad and apply to the bottom of the cabinet.
- For chassis shipped inside cabinet, remove and discard four shipping bolts.
- Remove inner panel (eight screws) and save for re-installation after chassis is installed.
- For standard cabinets shipped with risers attached, remove and discard the condensate pan shipping-wire ties. Lift pan approximately 2 inches to check drain hose is attached and clamped to pan and riser stub.

Prepare chassis for installation as follows:

- Verify refrigerant tubing is free of kinks or dents and that it does not touch other tubes or unit parts as it passes over or through. Adjust if needed and separate with closed cell insulation.
- Inspect all electrical connections. Connections must be clean and tight at the terminals.
- If chassis is not installed in cabinet, store in original carton in a clean and dry location.

Riser and Cabinet Installation

WARNING

To avoid damage from clogged coil surfaces, clogged motor ventilation openings, seized fan blades and potential unit failure, DO NOT OPERATE UNIT without complete enclosure, supply grille, return air panel and filter in place.

CAUTION

To ensure correct riser positioning and to compensate for variations in floor-to-floor dimensions, do not allow the unit to unit riser joint to bottom out.

CORE DRILLING FOR VERTICAL RISER STACK

Core drilling slab slot/holes determine cabinet placement and surrounding walls. Slot/holes size, location on floor, and plumb alignment in two planes from top to bottom are all very important. Reference plans. The size of the slot/hole will depend on slab thickness, ceiling height, riser length, if risers are attached to cabinet, which side risers are on, and how cabinet is angled into final position. Please see the SM product catalog for reference.

RISERS

Risers can be ordered loose, not attached to the cabinet and shipped in bulk separately. Crates have layers of risers by floors. Each cabinets' three risers (S,R,D) are next to each other. The lowest floor is on top layer. Risers have a tag with the floor and riser number (if the project information is filled out on the Solution Center vertical stack selection screen). You can assemble, pressure test, flush, and fill entire riser stacks before setting cabinets. Use caution if filled risers are in unconditioned space, prevent freezing. Do not construct walls until cabinets are set.

Risers may be different for every location and floor - check before installing. All couplings and reducers are to be field-supplied.

Before brazing check building plans to be sure you are installing correct riser; description of riser, diameter, type, and shutoff size are all variations. See Figure 2 on page 22 for help in identifying riser and dimension to set riser run out. Note that the riser dimension is from bottom of cabinet. Add if stand or thick isolation pads are used to get correct dimension from floor.

If local codes allow, PVC-drain risers may be used.

DESCRIPTION

Supply and return risers can be straight, transition up, transition down, bottom capped, or top capped. Drain risers can be straight, transition up, or top capped. All drain risers and extended range (operation below 60°F (15.5°C) or above 105°F (40.5°C) entering water temperature) supply and return risers need insulation.

RISER DIAMETER (NOMINAL WATER SIZE)

1 inch, 1½ inches, 1½ inches, 2 inches, 2½ inches, 3 inches. The top of the riser and the bottom of the riser on the floor above must be same diameter.

Vertical Stack Components		
1	Supply, Return, and Condensate Risers (not shown)	} Install Now
2	Cabinet	
3	Cabinet Inner Panel and Filter	
4	Chassis	} Install Later
5	Return Air Panel	
6	Supply Air Grille	
7	Thermostat (not shown)	
8	Hoses (not shown)	} Install Now
9	Optional Stand (not shown)	

Figure 1: Vertical Stack and Components

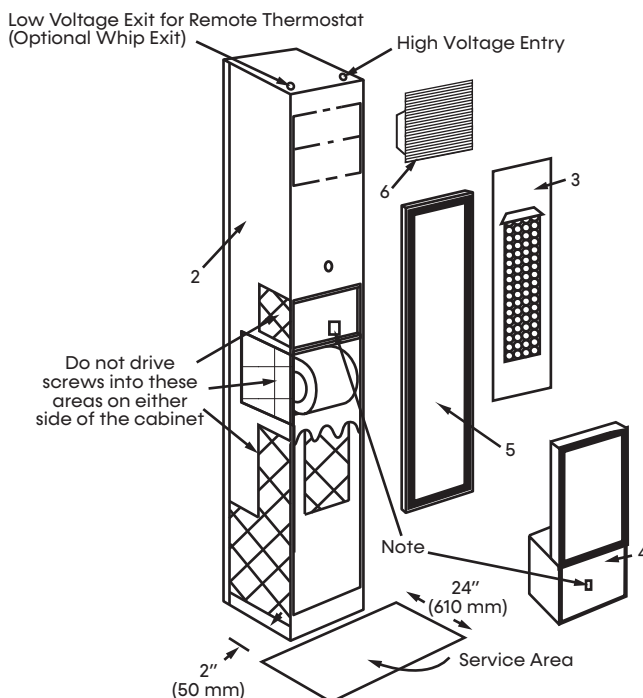

Models:
SM
006-036

Riser and Cabinet Installation

WARNING

To prevent electrical shorts and drain pan leaks, assure that screws do not penetrate unit components when driving screws near the unit control box or drain pan. Do not allow screws or nails to penetrate chassis, risers, electrical junction boxes, raceways or to interfere with chassis removal. To avoid motor or compressor damage, keep drywall dust out of the unit.

Type M has red identification marking (stripe running down the tube) and Type L (thicker wall) has blue identification marking. If tube is insulated, pull back carefully to check the color.

SHUTOFF BALL VALVES AND HOSE SIZES FOR CABINET/CHASSIS

1/2-inch for sizes 06-12, 3/4-inch for 15-18, and 1-inch for sizes 24-36.

The supply riser is always closest to back corner of cabinet, the return riser next, and drain riser in approximately middle of the cabinet. Supply risers are 9¼-inches (235 mm) apart from drain on centerline. See Figure 2 and Figure 3 on page 22.

Secure Riser Stack to building structure so stack does not drop over time. Cabinet slots allow for 1½-inches (38 mm) maximum expansion and 1½-inches (38 mm) maximum contraction, use expansion devices between clamps and if you exceed these values.

NOTICE

Any risers misplaced, assembled in wrong location, brazed incorrect, modified incorrect (including cutting off or extending), runoff at incorrect height, misalignment found anytime including when cabinets are set, not using expansion devices if specified, or stack was not supported correctly is the sole responsibility of the installing contractor.

RISER INSTALLATION WHEN RISERS ARE SHIPPED SEPARATELY

1. Check riser diameter, type, valve size, and position (S, R, D or D, S, R) of risers per cabinet configuration (see floor plans).
2. Suggest each cabinet location be marked with all information (see Figure 4 on page 22).
3. Starting on lowest floor center risers in slot. Set height of supply and return run-outs to 39¼-inches (1100 mm) and drain run-out to 3.12-inches (79 mm) from bottom of cabinet. Temporarily secure risers (not by rubout or valve) so they do not move.
4. If riser extensions are used insert them on lower floor top of riser, mark like step 5.
5. Next floor up mark riser at bottom at 1-inch (25 mm) and 2½-inch (63 mm), drop through slot and position run-outs same as step 2. Temporarily support.
6. On lower floor check that above riser is inserted between 1-inch (25 mm) and 2½-inches (63 mm) (between the two marks you made). Cut riser or use extension if needed.
7. Insert expansion devices if required by plans.
8. Continue until complete riser stack is assembled.
9. Check all risers are correct diameter, type, valve size; correctly positioned; centered in slot; plumb from top to bottom; depth into swedge correct; run-outs at correct height, and shutoff valve handles are parallel with the side of cabinet. (see Figure 2)
10. Braze all joints with high-temperature alloy like Phoscopper or Silfos. (DO NOT use soft solder 50-50, 60-40 or 85-15; low-temperature alloys are not acceptable for this application).
11. You must securely anchor riser stacks to the building structure on at least one floor. Typically on middle floor and additional floors as needed. Example: 40 floors, anchor at 10, 20, and 30. Use expansion devices between anchors.
12. Remove temporary supports.
13. Check that risers did not drop. If the stack dropped, jack up and add additional anchor support.
14. Verify all shutoff valves are closed. DO NOT OPEN VALVES until the system is cleaned and flushed.
15. Pressure test risers. Locate and repair any leaks then retest.
16. To facilitate cleaning and flushing, install the hose kit at the end farthest from the pump and connect the ends of the hoses with the riser flush adapter (Kit - AFL5751). Then open both valves before pumping fresh water through the system. Close the valves when the system is clean. Remove the flush adapter before installing the chassis. **NOTE: Refer to System Flushing Section of this manual for more information.**
17. Install air vents in piping loop at highest accessible point as required to bleed the system of air accumulated during installation.

Riser and Cabinet Installation

CABINET INSTALLATION WHEN RISERS ARE SHIPPED SEPARATELY OR FIELD-PROVIDED

1. Check plans that cabinet is correct for location, cabinet will have label and data plate with information, including unit size, diameters of risers, and electrical data.
2. Remove riser KO's (3) for your cabinet configuration (see Figure 2).
3. Cover supply and return openings with 4 pads. Slit with knife (see Figure 7a).
4. Slide cabinet up to riser allowing ¼-inch to 1-inch (6 to 25 mm) clearance.
5. Attach the cabinet assembly to the floor on at least two sides using sheet metal angles. Additional anchorage may be provided by installing brackets at the top of the cabinet.
 - a. Anchor built-in risers to the building structure with at least one contact point. To accommodate vertical expansion and contraction DO NOT fasten risers rigidly within the unit.
 - b. Verify that unit shut-off valves are closed. DO NOT OPEN VALVES until the system has been cleaned and flushed.
6. For cabinets with chassis inside - remove four shipping screws, discard.
7. Remove inner panel (eight screws), save both.
8. Remove condensate pan shipping wire ties.
9. P-Trap Hose must be connected, lift drain pan, extend drain riser stub into cabinet, measure and cut drain hose to length, connect rubber p-trap to riser and clamp. If condensate hose must be rotated, loosen clamp on pan, rotate, and re-clamp. Check condensate drain - clean pan if needed. Slowly pour 1 to 2 quarts (1 to 2 liters) of water into pan. The water should drain freely. Check for water in the cabinet and on the floor. Repair if needed, and then retest.
10. Sheet metal ductwork should not be attached to the cabinet. A canvas-type flexible connection is recommended between the cabinet and the ductwork.

CABINET INSTALLATION WHEN RISERS ARE ATTACHED (SEE FIGURE 2)

1. Check plans that cabinet is correct for location. The cabinet has a label and dataplate with information including unit size, diameters of risers, and electrical data (if the project information is filled out on the Solution Center vertical stack selection screen). Move cabinet close to the slab slot. Do not carry the cabinet using risers and always use two people.
2. Check risers are 3-inches above the top of cabinet. If not loosen straps, adjust riser and re-tighten.
3. For applicable cabinet options configure supply air openings and attach angles. See Pre-Installation. If optional stand is required attach to bottom of cabinet with four screws.
4. Start on lowest floor, lift cabinet and angle so risers pass through slab slot/holes until the cabinet is standing up and sitting on floor. Be careful not to damage either end of riser and do not carry the cabinet using risers. Move the cabinet until risers are centered in slot/holes and cabinet sides are square with proposed walls. If extensions are used, assemble to risers on lower floor. Mark set depth in case they drop before brazing. Dimension should be 1-inch to 2-inches. Less than 1-inch or more than 2½-inches is not acceptable. Extensions should never bottom in swedge of riser. **NOTE: Riser joints should be well below slab for brazing/inspection.**
5. Attach the cabinet assembly to the floor on at least two sides using sheet metal angles. You can provide additional anchorage by installing brackets at the top of the cabinet.
6. DO NOT attach drywall studs to cabinet. When all units on a riser are anchored into place, complete riser joints as follows:
 - a. Verify that all riser joints are vertically aligned and that risers penetrate 1-inch to 2-inches (25 to 50 mm) into the swaged joint of the riser below. DO NOT let riser joint bottom out. Check run outs enter cabinet at 90°.

Models:
SM
006-036

Riser and Cabinet Installation

- b. Braze riser joints with a high-temperature alloy (such as Phoscopper or Silfos). Soft solder (50-50, 60-40 or 85-15) or low-temperature alloys are NOT suitable for this application.
 - c. Must securely anchor riser stacks to the building structure with at least one contact point. Typically at middle floors as needed. Example, a 40 floor building would be anchored at floors 10, 20, and 30. To accommodate vertical expansion and contraction use expansion devices between anchors. DO NOT fasten risers rigidly within the unit.
 - d. Verify that unit shut-off valves are closed. DO NOT OPEN VALVES until the system has been cleaned and flushed.
 - e. Pressure test riser - locate and repair leaks.
 - f. If condensate hose must be rotated, loosen clamp on pan, rotate, and re-clamp. Check condensate drain - clean pan if needed. Slowly pour 1 to 2 quarts (1 to 2 liters) of water into pan. Water should drain freely. Check for water in cabinet and on floor. Repair if needed.
 - g. Repair or replace any damaged or missing insulation on risers and extensions (if used).
 - h. To facilitate cleaning and flushing, install the hose kit at the end farthest from the pump and connect the ends of the hoses with the riser flush adapter (Kit - AFL5751). Then open both valves before pumping fresh water through the system, close the valves when the system is clean. Remove the flush adapter before installing the chassis. **NOTE: Refer to System Flushing Section of this manual for more information.**
 - i. Install air vents in piping loop at highest accessible point as required to bleed the system of air accumulated during installation.
7. Next floor up select correct unit. Suggest measuring from top of slab to top of riser below. Now measure from bottom of cabinet (or stand/pad if used) to bottom of riser, this dimension should be 1-inch to 2-inches more than first measurement. Less than 1-inch or more than 2½-inches is not acceptable. Risers should never bottom in swedge below. Cut riser or extension if needed. DO NOT slide riser up or down on cabinet. Repeat steps 2-5.

SUPPLY AND RETURN STACK

1. Install a drain valve, shut-off/balancing valves, flow indicators and drain tees at the base of each supply and return riser stack to enable system flushing at startup, balancing and during servicing.
2. Install strainers at the inlet of each circulating pump.
3. Insulate loop water piping which runs through non-conditioned areas or outside the building. For boiler tower applications loop temperature is normally between 60°F and 90°F, piping does not sweat or suffer heat loss under ambient conditions. For geothermal applications insulate all loop water piping.
4. Cabinet slots and riser stack assemblies are designed to accommodate a maximum of 1½-inch (38 mm) expansion and 1½-inch (38 mm) contraction. If the calculated riser stack expansion or contraction exceeds 1½-inch (38 mm), expansion devices must be provided.

CONDENSATE PIPING

Standard and Leader cabinets (risers shipped attached to the cabinet) - The condensate connection between the drain pan assembly and condensate riser is factory installed, clamped, and trapped in cabinet. Follower cabinets (risers shipped loose or field-provided) installer must clip and remove two drain pan shipping ties, lift drain pan, extend drain riser stub into cabinet, measure and cut drain hose to length, then connect rubber p-trap to riser and clamp.

NOTICE

Loose risers with brazed shutoff! Make sure shutoff handles are parallel with riser entry side of cabinet before brazing stack.

Riser and Cabinet Installation

OPTIONAL FRAME FOR RETURN AIR G PANEL

Position the studs in front of the cabinet and install the frame in the opening. Seal the gap between the cabinet and the frame. If a fresh-air motorized-damper assembly is used, field-fabricate and install a duct from outside to the frame opening. The assembly is installed later. See instructions with assembly.

NOTICE

Allow for drywall thickness under frame front flange.

NOTICE

ClimateMaster is not responsible for wallboard repair if 2 x 4 box was not in correct orientation.

Install studs and drywall using conventional construction methods. Secure the drywall to studs with low-profile, pan-head sheet-metal screws. Drywall must not be fastened to drain pan edges or control box enclosure. Drywall can be attached directly to cabinet (except in places indicated in Figure 1 on page 17. The front of cabinet requires double thickness. Do not attach drywall studs to cabinet. Do not install drywall using adhesive alone.

See typical construction Figure 4 and Figure 5 on page 23, and Figure 10 on page 36 to determine stud layouts and dimension from cabinet to finished wall.

OPTIONAL FIELD-SUPPLIED DUCT INSTALLATION

When return air is required to enter the unit through openings in a stud wall, supply and field-install an optional duct. Seal the duct against the return air grille. Add a blockoff above and below the chassis to ensure that all air entering the unit passes through the filter and refrigerant-to-air coil. Sheet-metal ductwork must not be attached to the cabinet. A canvas-type flexible connection should be used between the cabinet and the ductwork.

When supply air is ducted from unit, sheet metal ductwork must not be attached to the cabinet. A canvas-type flexible connection should be used between the cabinet and the ductwork.

Vacuum all drywall dust and construction debris from cabinet insulation, drain pans, and blower-discharge plenum after cutting out supply and return holes for grilles. Place insulation between the drywall and the cabinet for sound attenuation.

When installation is complete, cover all cabinet openings and exposed sheet metal. You can use cardboard from the unit shipping cartons. Do not allow paint or wall texture over-spray to contact insulation, sheet metal, coil, fan, or other unit components. Warranties are void if paint or other foreign debris is allowed to contaminate internal unit components.

Do not adjust the Sight and Sound X-baffle (see Figure 6 on page 24). It is not designed to be used as a damper.

DRYWALL INSTALLATION

If you have the surface mounted thermostat option (cabinet model digit 9 = S or 5), make sure before you install the drywall that the 2x4 junction box is in the correct orientation. Turn if needed. Check your thermostat.

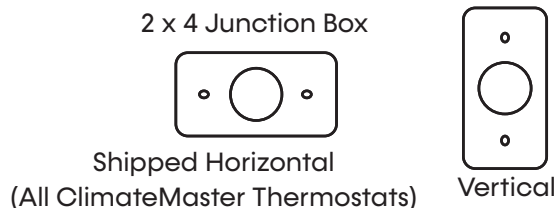

For best sound attenuation, do not to attach studs or drywall to cabinet.

Models:
SM
006-036

Riser and Cabinet Installation

Figure 2: Riser Placement

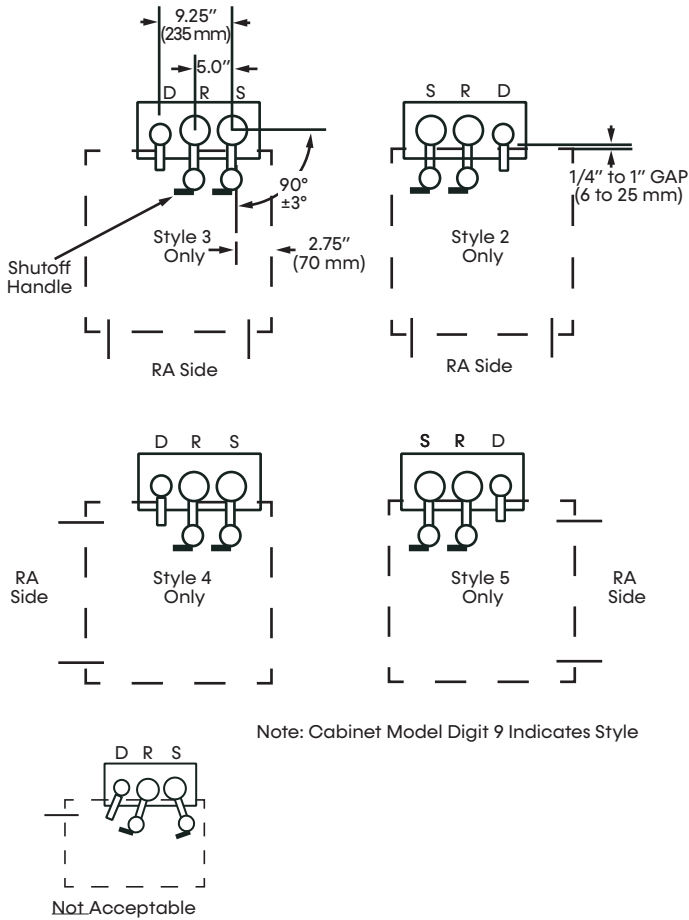

Riser Setting Detail

Cabinet	Size	Valve FPT
06, 09, 12	06-12	1/2" (13 mm)
15, 18	15-18	3/4" (19 mm)
23, 30, 36	24-36	1" (25 mm)

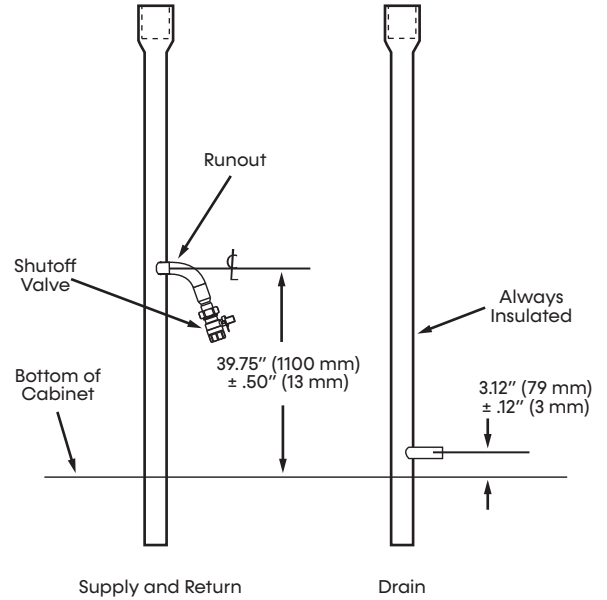
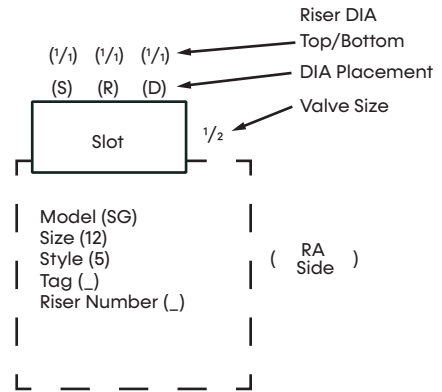
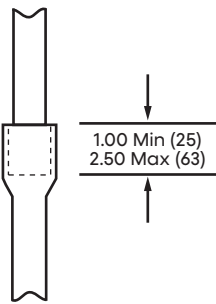
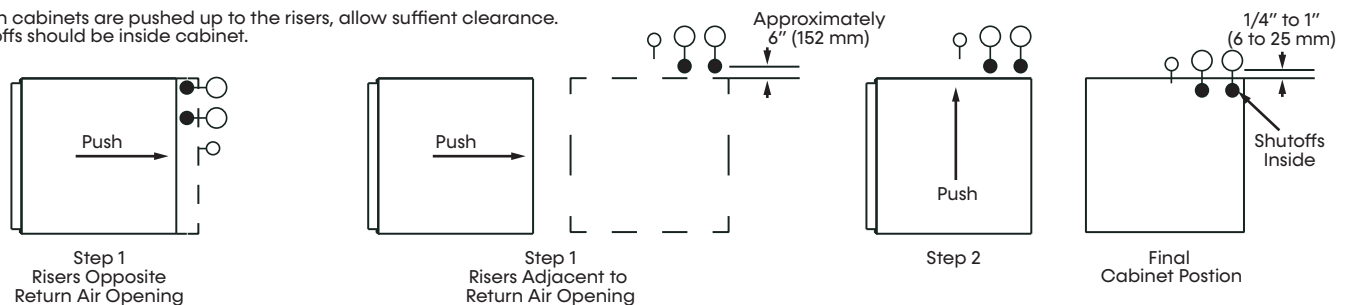

Figure 4: Suggested Floor Markings (change data for your unit)

Figure 3: Riser or Extension Insertion



When cabinets are pushed up to the risers, allow sufficient clearance. Shutoffs should be inside cabinet.



Riser and Cabinet Installation

Figure 5: Riser Identification

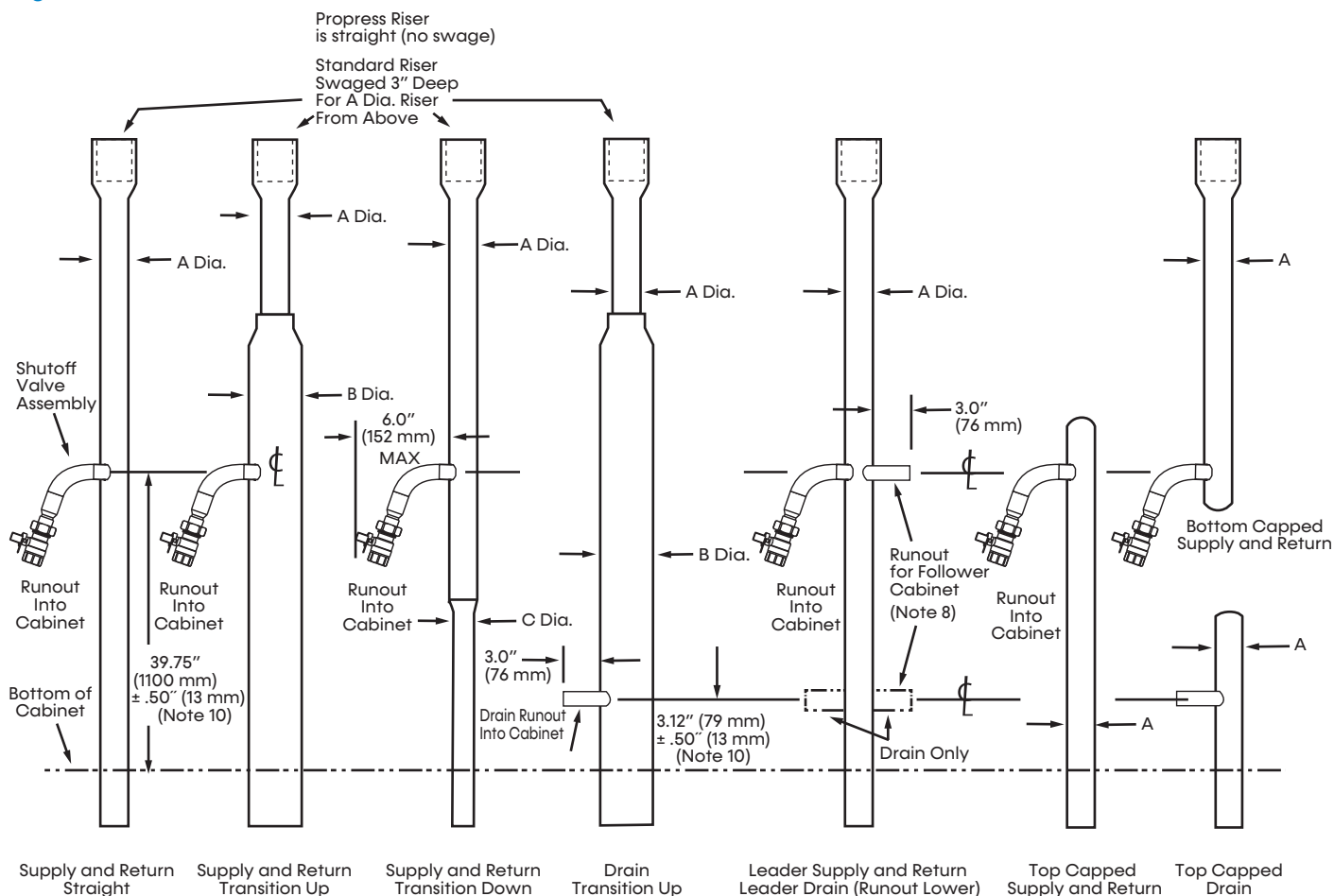

Notes:

- You must know water flow direction to determine if cabinet requires transition up or down.
- Transitions can only change by one diameter (1-inch to 1¼-inches, 1¼-inches to 1½-inches, etc.)
- Riser transition couplings and run outs are factory brazed.
- All risers are factory pressure tested.
- Standard riser diameters are nominal 1-inch, 1¼-inches, 1½-inches, 2-inches, 2½-inches, and 3-inches. Please consult the factory on pricing for nominal 4-inch water tubing.
- Copper Type M and L available (4-inch L only).
- Drain riser insulated standard. Insulation is optional for supply and return
- Leader riser - For follower cabinet riser ball valve assemblies, 12-inches of straight copper are provided for field connection to the leader riser. Assembly to be cut to length and field brazed. In applications where more than 12-inches of straight copper is needed, copper and fittings to be field-provided.
- Standard ball valves have NPSH threads for connection to AHU hoses ½-inch for sizes 06-12, ¾-inch for 15-18, and 1-inch for sizes 24-36.
- If cabinet stand or thick ISO pad is used, at installation add height/thickness to shutoff valve and drain run out height. Verify riser shutoff height with plans before brazing.

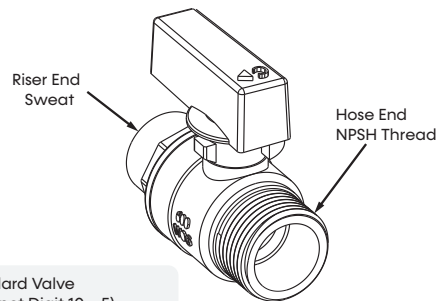

Standard Valve
(Cabinet Digit 10 = 5)
Used with AHU-Style Hoses

	Riser Diameter (in)						
A	1.00	1.25	1.50	2.00	2.50	3.00	4.00
B	1.25	1.50	2.00	2.50	3.00	-	-
C	-	1.00	1.25	1.50	2.00	2.50	-

NOTE: ClimateMaster units with the motorized-valve option have high-pressure water switches. Do not design the riser stack where switch will not reset (trip - 300 PSI; Reset - 250 PSI).

Models:
SM
006-036

Riser and Cabinet Installation

Figure 6: Cabinet

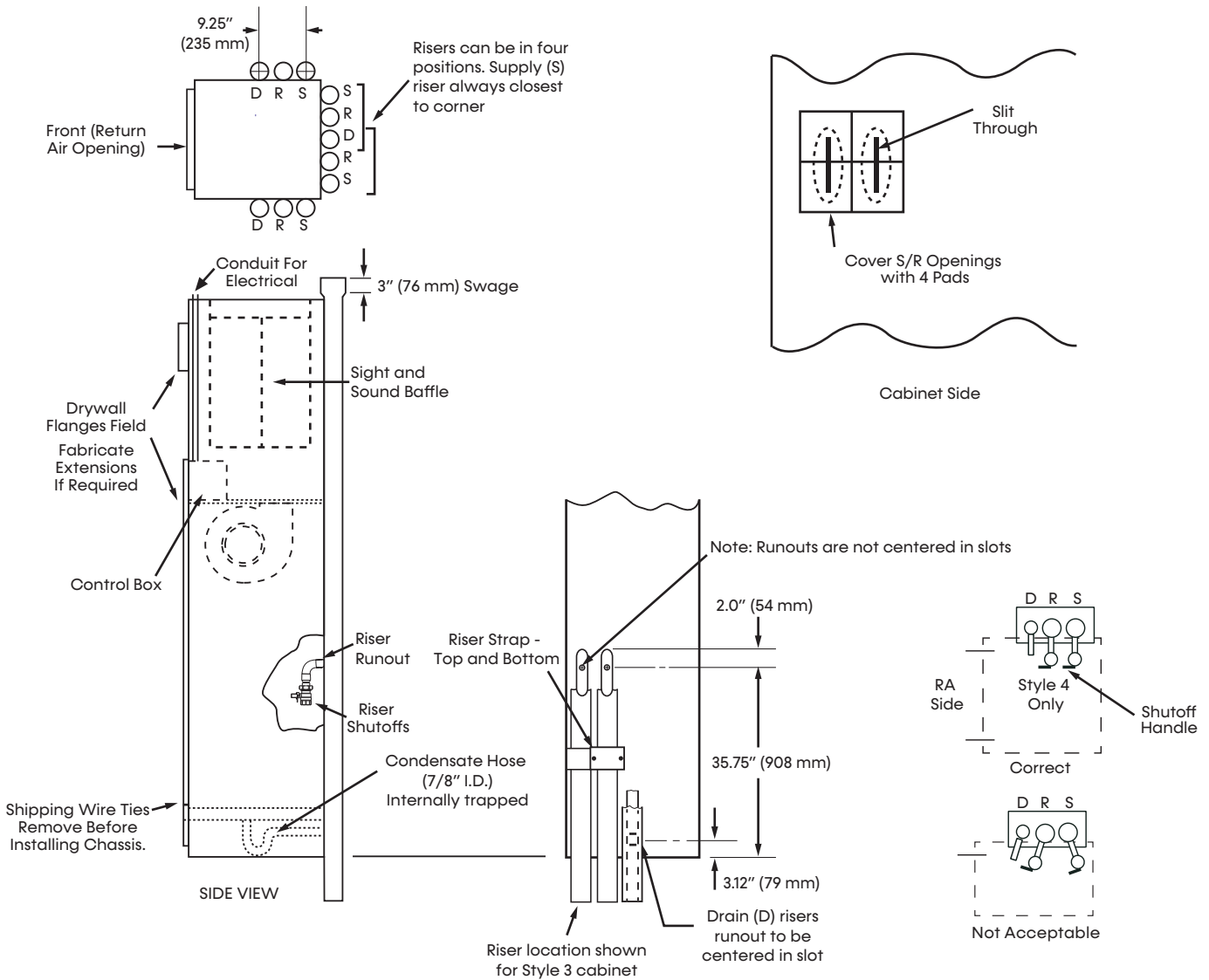

Notes:

1. For chassis shipped in cabinet remove and discard four shipping bolts.
2. Supply (S) and Return (R) risers may have moved during shipping. Check, they must be 3-inches (76 mm) above top of cabinet. Loosen straps and readjust any if needed, then re-tighten. After riser stack is completed and secured to building structure, straps can be removed.
3. When risers are attached at the factory, p-trap drain hose is attached and clamped at cabinet drain pan and drain riser. When risers are field provided or shipped separate, run copper drain stub into cabinet, measure and cut rubber drain hose to length, connect and clamp drain hose to the drain riser.
4. Before installing chassis – check drain hose is connected and clamped at both ends, and drain pan is free and setting on four rubber grommets.

ATTENTION

Supply (S) and Return (R) risers may have moved during shipping. Check, they must be 3 inches (76 mm) above top of cabinet and shutoff handles are parallel with side of cabinet before brazing stack. Loosen straps and readjust any if needed, then re-tighten. After riser stack is completed and secured to building structure, straps can be removed.

Leader/Follower Cabinet Installation

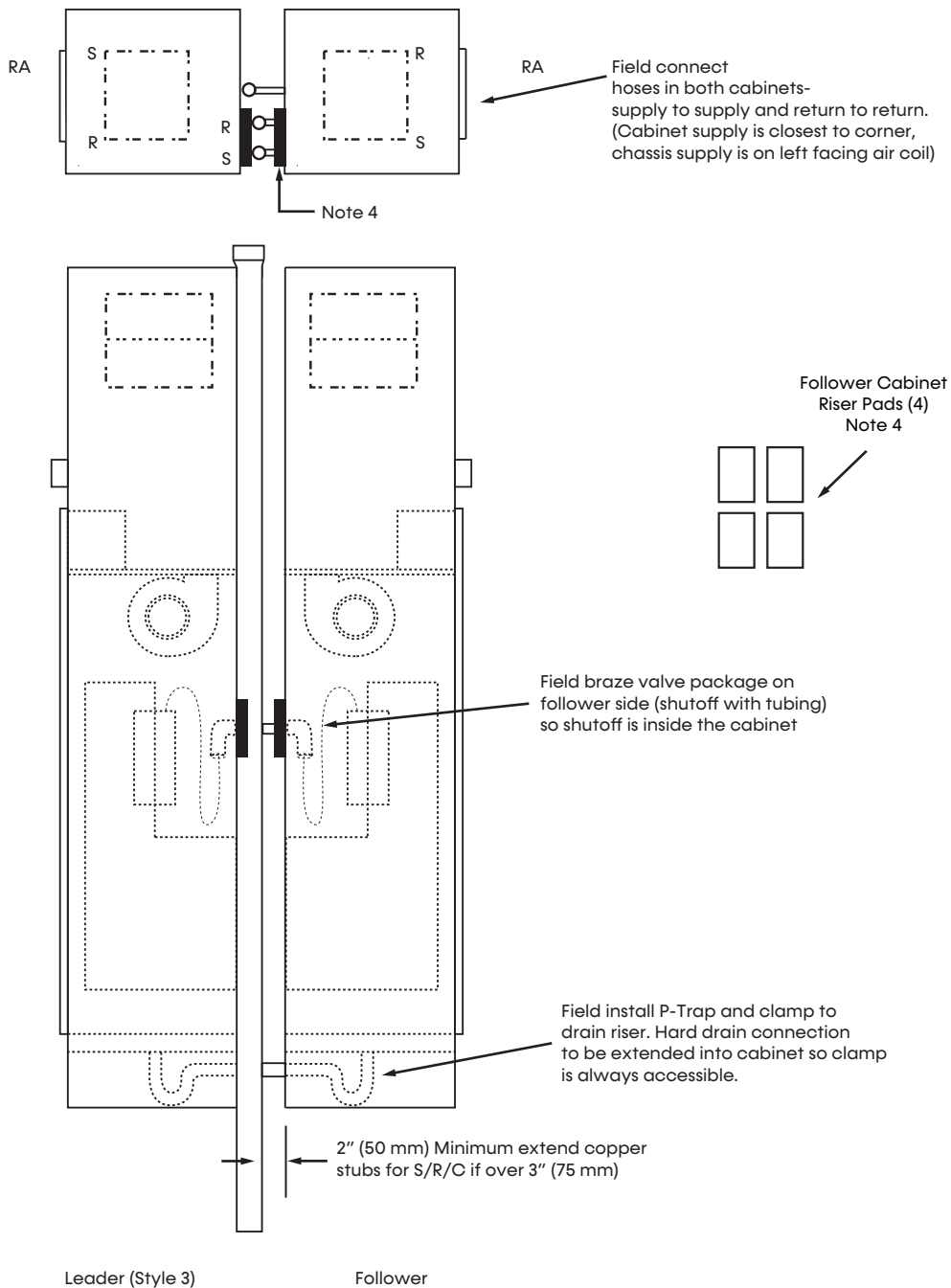

Notes:

1. Contractor must meet all fire code requirements.
2. Size riser diameter for both units GPM.
3. Leader/Follower means both units share common riser.
4. Install pads on back of follower cabinet to cover slots used for S/R risers.

Models:
SM
006-036

Standard (SMS) Cabinet Dimensions

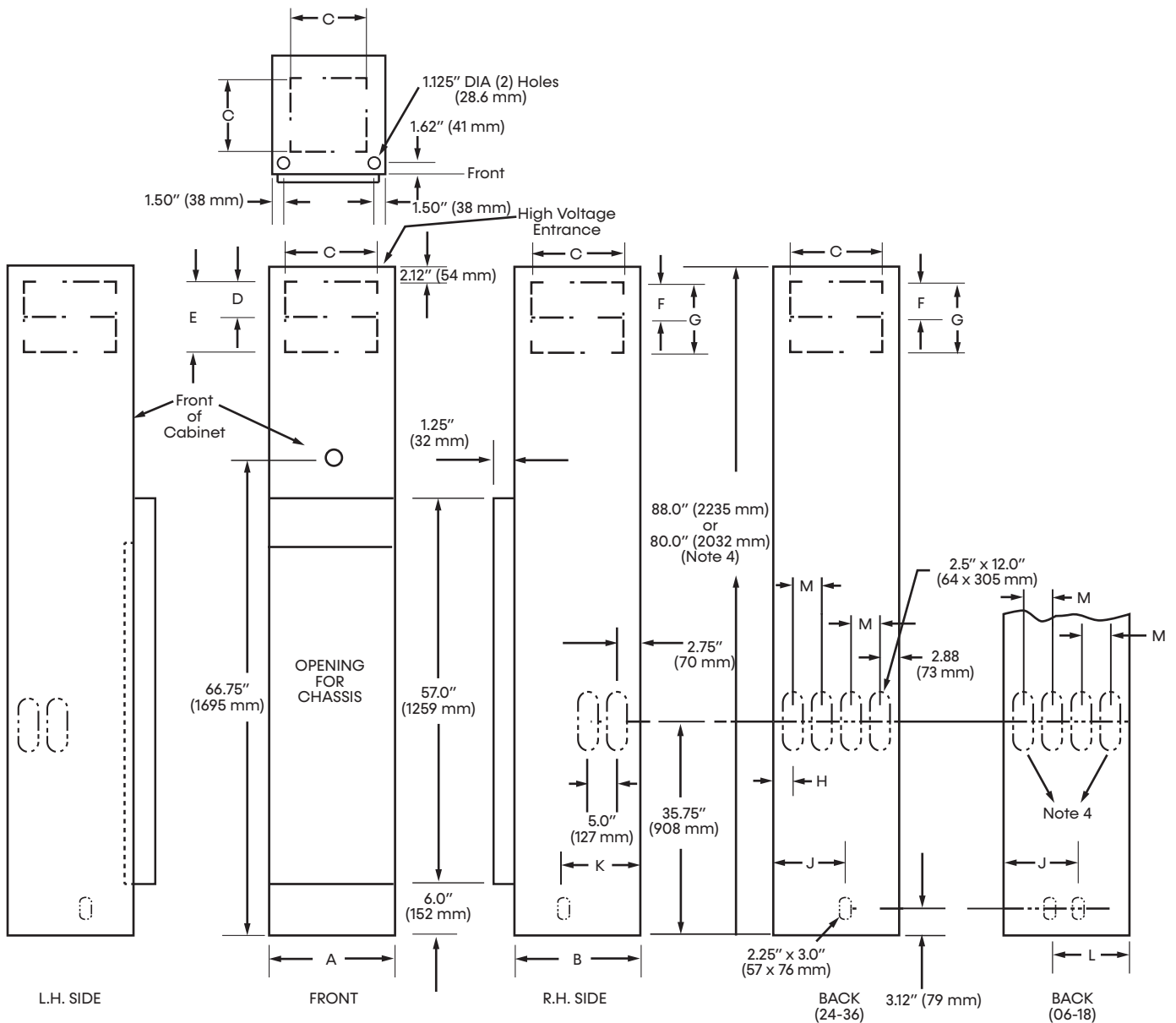

Notes:

1. All dimensions are in inches (mm).
2. Cabinets have supply air and riser K.O.s, all panels. Remove only K.O.s necessary to configure cabinet. Seal any K.O.s removed by mistake.
3. Service area to be width of cabinet plus 4-inches (102 mm) and 24-inches (610 mm) from finished wall.
4. For 06-18 cabinet use drain diagonally across from supply and return risers.

Size	A	B	C	88" Cabinet		80" Cabinet		H	J	K	L	M
				D/F	E/G	D/F	G					
06-12	17.00 [432]	17.00 [432]	12.00 [305]	6.00 [152]	12.00 [305]	6.00 [152]	12.00 [305]	1.71 [44]	11.34 [288]	11.93 [303]	11.34 [288]	4.63 [117]
15-18	19.25 [489]	19.00 [483]	14.00 [356]	6.00 [152]	14.00 [356]	6.00 [152]	12.00 [305]	2.83 [72]	12.08 [307]	11.93 [303]	12.08 [307]	4.63 [117]
24-36	24.25 [616]	24.00 [610]	16.00 [406]	8.00 [203]	16.00 [406]	6.00 [152]	12.00 [305]	2.83 [72]	12.08 [307]	11.98 [304]	N/A	5.00 [127]

Ducted (SMT) Cabinet Dimensions

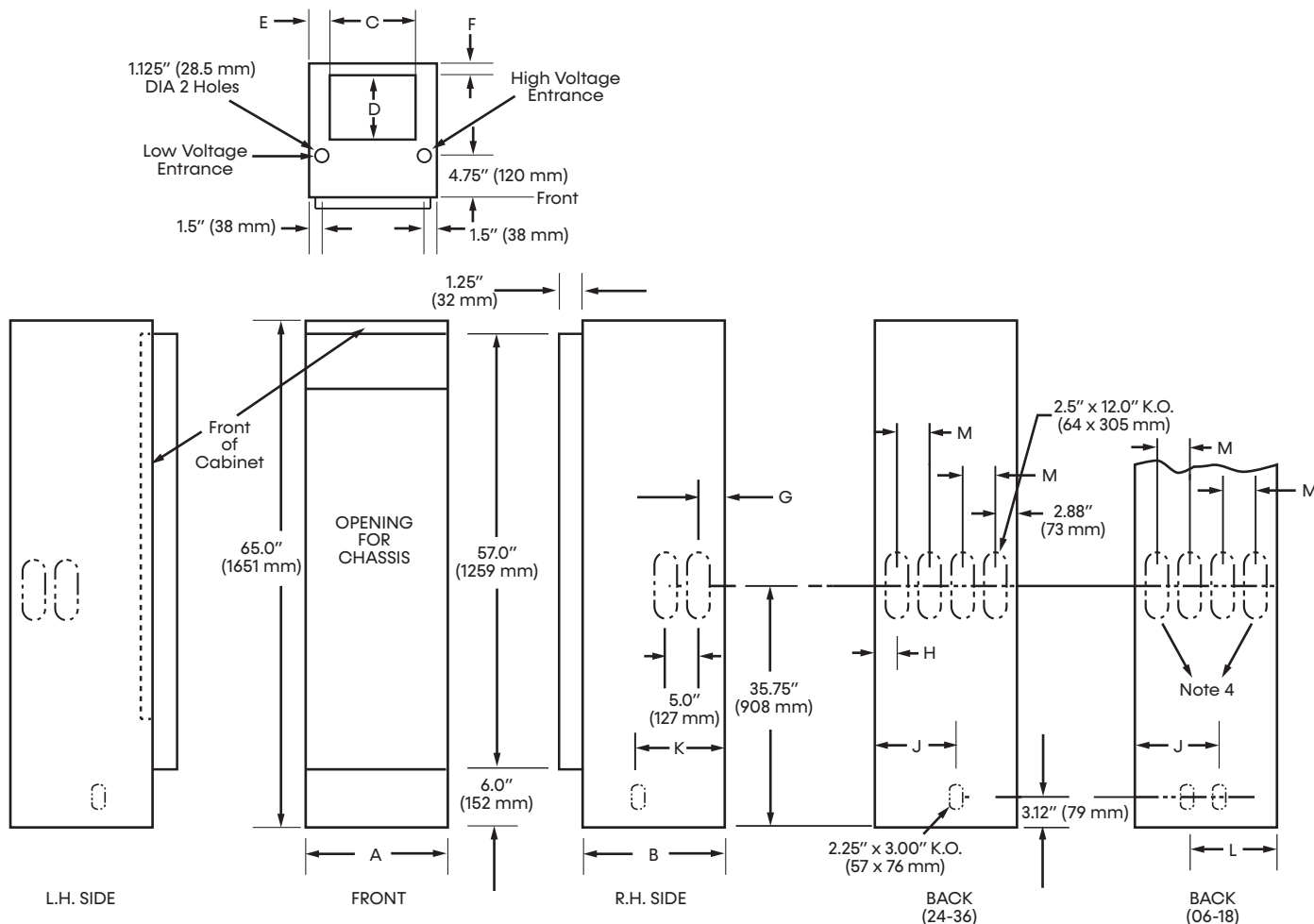

Notes:

1. Dimensions shown are in inches and either mm or cm unless noted otherwise.
2. Style refers to the riser location (digit 9 in Model Nomenclature).
3. Return air side is the front of the cabinet.
4. Supply riser is closest to corner.
5. Drain is not centered on size 06-18 cabinets.
6. Slots allow for riser-stack expansion and contraction.
7. Supply and return riser stub outs are 39.75-inches (1100 mm) from bottom of cabinet and is not centered vertically in slot. Drain Run-out is 3.12-inches (79 mm) from bottom of cabinet.
8. From floor to floor on one riser stack you can only have; all same style, styles 2 and 5; or styles 3 and 4. For leader/follower units you can only have styles 3 or 4 adjacent to 2 or 5.
9. Secure riser stack to building structure.
10. Riser should not touch cabinet and shutoff should be inside cabinet.

Size	A	B	C	D	E	F	G	H	J	K	L	M
06-12	17.00 [432]	17.00 [432]	11.50 [292]	6.00 [152]	2.62 [67]	0.665 [17]	2.75 [70]	1.71 [44]	11.34 [288]	11.93 [303]	11.34 [288]	4.63 [117]
15-18	19.25 [489]	19.00 [483]	11.50 [292]	6.00 [152]	3.87 [93]	0.665 [17]	2.75 [70]	2.83 [72]	12.08 [307]	11.93 [303]	12.08 [307]	4.63 [117]
24-36	24.25 [616]	24.00 [610]	12.00 [305]	12.00 [305]	6.12 [156]	1.04 [26]	2.73 [69]	2.83 [72]	12.08 [307]	11.98 [304]	N/A	5.00 [127]

Models:
SM
006-036

Standard and Ducted Cabinet Slot Dimensions and Riser Arrangements

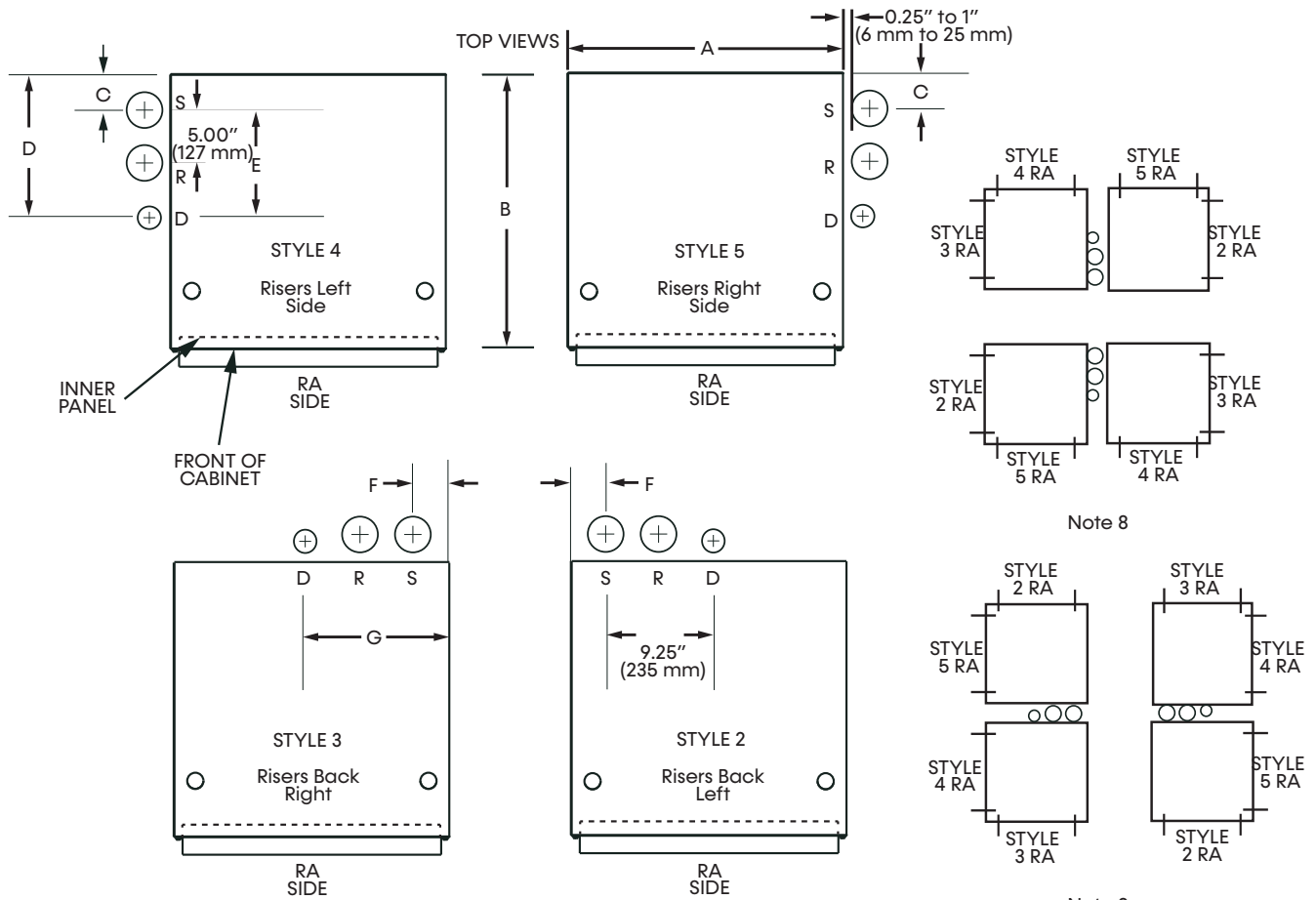

NOTICE

Not all styles will stack above or adjacent to each other. (See Note 8).

Notes:

1. Dimensions shown are in inches and either mm or cm unless noted otherwise.
2. Style refers to the riser location (digit 9 in Model Nomenclature).
3. Return air side is the front of the cabinet.
4. Supply riser is closest to corner.
5. Drain is not centered on size 06-18 cabinets.
6. Slots allow for riser stack expansion and contraction.
7. Supply and return riser stub outs are 39¾-inches (1100 mm) from bottom of cabinet and is not centered vertically in slot. Drain Run-out is 3.12-inches (79 mm) from bottom of cabinet.
8. From floor to floor on one riser stack you can only have; all same style, styles 2 and 5; or styles 3 and 4. For leader/follower units you can only have styles 3 or 4 adjacent to 2 or 5.
9. Secure riser stack to building structure.
10. Riser should not touch cabinet and shutoff should be inside cabinet.

Size	A	B	C	D	E	F	G
06-12	17.00 [432]	17.00 [432]	2.75 [70]	11.93 [303]	9.18 [233]	1.71 [44]	11.34 [288]
15-18	19.25 [489]	19.00 [483]	2.75 [70]	11.93 [303]	9.18 [233]	2.83 [72]	12.08 [307]
24-36	24.25 [616]	24.00 [610]	2.73 [69]	11.98 [304]	9.25 [235]	2.83 [72]	12.08 [307]

80-inch and 88-inch Cabinet Configurations

Back/Front/Top Discharge Options – Digit 11

Option	Discharge	Unit Size 06-12 Top	Unit Size 15-18 Top	Unit Size 24-36 Top	C-Series 80" SM	C-Series 88" SM
0	None	N/A	N/A	N/A	Yes	Yes
A	Back Small					
B	Back Large					
C	Front Small					
D	Front Large	12 x 12	14 x 14	16 x 16	No	
E	Top					
F	Back Small and Top					
G	Back Large and Top					
H	Front Small and Top	12 x 12	14 x 14	16 x 16	Yes	
J	Front Large and Top					
K	Back Small and Front Small					
L	Back Large and Front Large					
M	Back Small and Front Large	N/A	N/A	N/A	No	
N	Back Large and Front Small					
P	Back Small and Front Small w/Top					
Q	Back Large and Front Large w/Top					
R	Back Small and Front Large w/Top	12 x 12	14 x 14	16 x 16	No	
S	Back Large and Front Small w/Top					

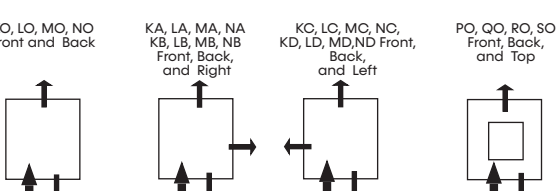
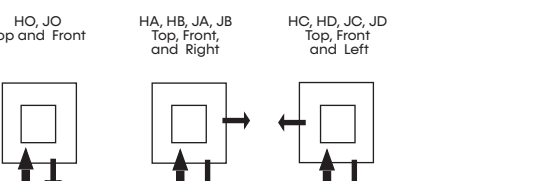
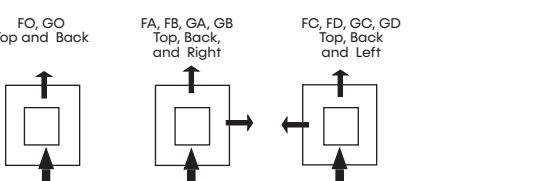
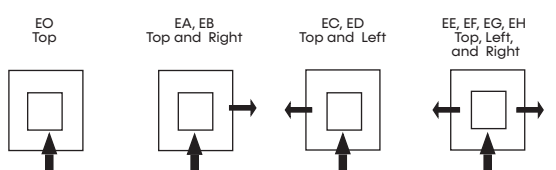
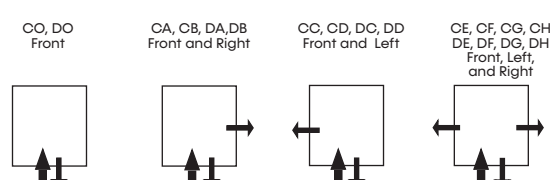
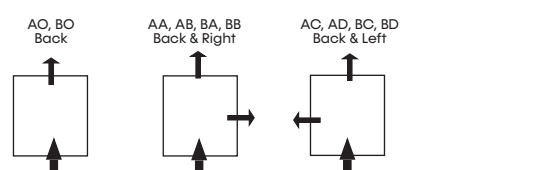
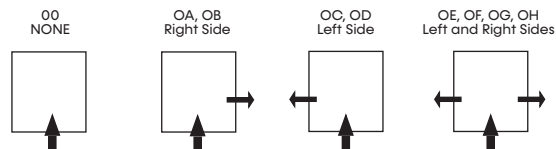

Side Discharge Options – Digit 12

Option	Discharge
0	None
A	Right Small
B	Right Large
C	Left Small
D	Left Large
E	Right Small & Left Small
F	Right Large & Left Large
G	Right Small & Left Large
H	Right Large & Left Small

Discharge K.O. By Unit Size 88"

T Size	Top	Back, Front & Side
06-12	12" x 12"	12" x 6" & 12" x 12"
15-18	14" x 14"	14" x 6" & 14" x 14"
24-36	16" x 16"	16" x 8" & 16" x 16"

Discharge K.O. By Unit Size 80"

T Size	Top	Front	Back & Side
06-12	12" x 12"	12" x 6"	12" x 6" & 12" x 12"
15-18	14" x 14"	14" x 6"	14" x 6" & 14" x 12"
24-36	16" x 16"	16" x 6"	16" x 6" & 16" x 12"

- Notes:
1. Front is return air side and control box location.
 2. Risers can be on any side without return or supply air openings.
 3. All sides and top have K.O.s.
 4. 80-inch cabinet cannot have front-large discharge.

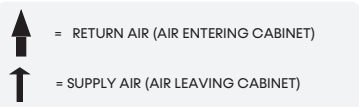

Models:
SM
006-036

Supply Grille Installation

SUPPLY GRILLE INSTALLATION

Cabinet opening should be sealed to wall. Use canvas-type flex collar or field-supplied duct extension if needed.

Refer to the Table 2 below to ensure that the grille size is correct based on the type and size of the supply-air grille.

- Install the grille into the cabinet-discharge opening. Assure that the grille flange rests against the drywall covering the cabinet. Do not caulk.
- Secure the grille to the drywall with the screws provided.

Table 2: Supply Grille Sizes and Arrangements

Unit Size	Single Discharge	Double Discharge	Triple Discharge
SM06	12" x 12" (305 mm x 305 mm)	12" x 6" (305 mm x 152 mm)	N/A
SM09	12" x 12" (305 mm x 305 mm)	12" x 6" (305 mm x 152 mm)	N/A
SM12	12" x 12" (305 mm x 305 mm)	12" x 6" (305 mm x 152 mm)	N/A
SM15	12" x 12" (305 mm x 305 mm)	12" x 6" (305 x 152)	12" x 6" (305 mm x 152 mm)
SM18	N/A	12" x 12" (305 mm x 305 mm)	12" x 6" (305 mm x 152 mm)
SM24	N/A	16" x 8" (406 x 203)	16" x 8" (406 mm x 203 mm)
SM30	N/A	16" x * (406 x -)	16" x 8" (406 mm x 203 mm)
SM36	N/A	16" x * (406 x -)	16" x * (406 mm x -)

Typical Cabinet with L Panel Installation

Unit	AVHRL Digit 6	D	E	F	G
06-12	1	22.1	2.0	19.5	55.8
15-18	2	24.1	2.0	21.5	55.8
24	3	29.6	2.0	26.5	55.9
30-36	4	29.6	2.0	26.5	55.9

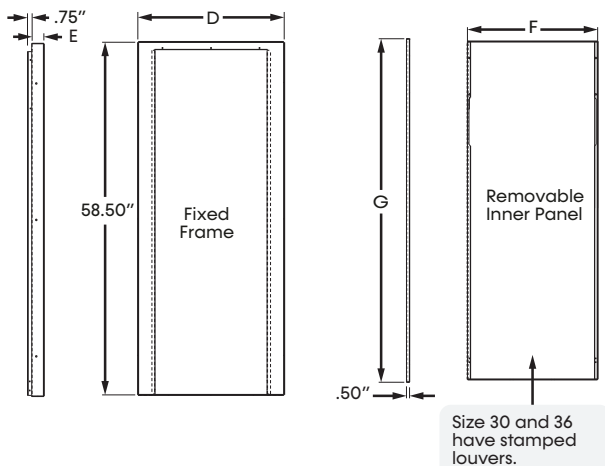

NOTICE

Frame is attached to studs. Panel is removable for chassis access.

FRAME INSTALLATION

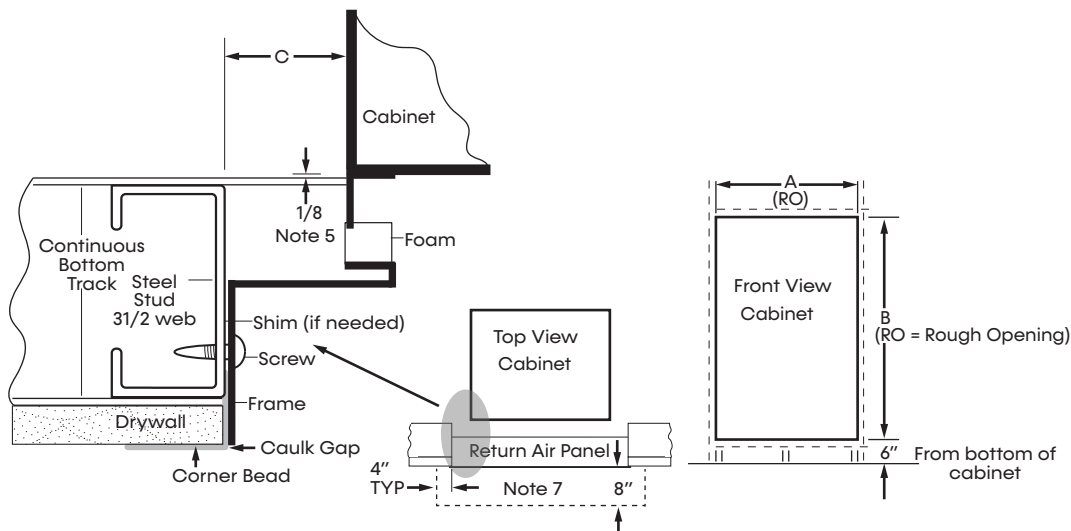

Notes:

1. Dimensions shown are in inches and either mm or cm unless noted otherwise.
2. Frame and panel painted Bright White or Polar Ice.
3. Panel is removable for filter replacement or chassis removal.
4. Frame ships with cabinet and must be installed while framing.
5. Set bottom track 1/8-inch in front of cabinet.
6. Drywall mud is added to the corner bead to produce a smooth finished surface.
7. Unobstructed area for required air flow.

Unit	A	B	C
06-12	22.3	58.6	2.5
15-18	24.3	58.6	2.5
24-36	29.7	58.6	2.7

Models:
SM
006-036

Typical Cabinet with G Panel Installation

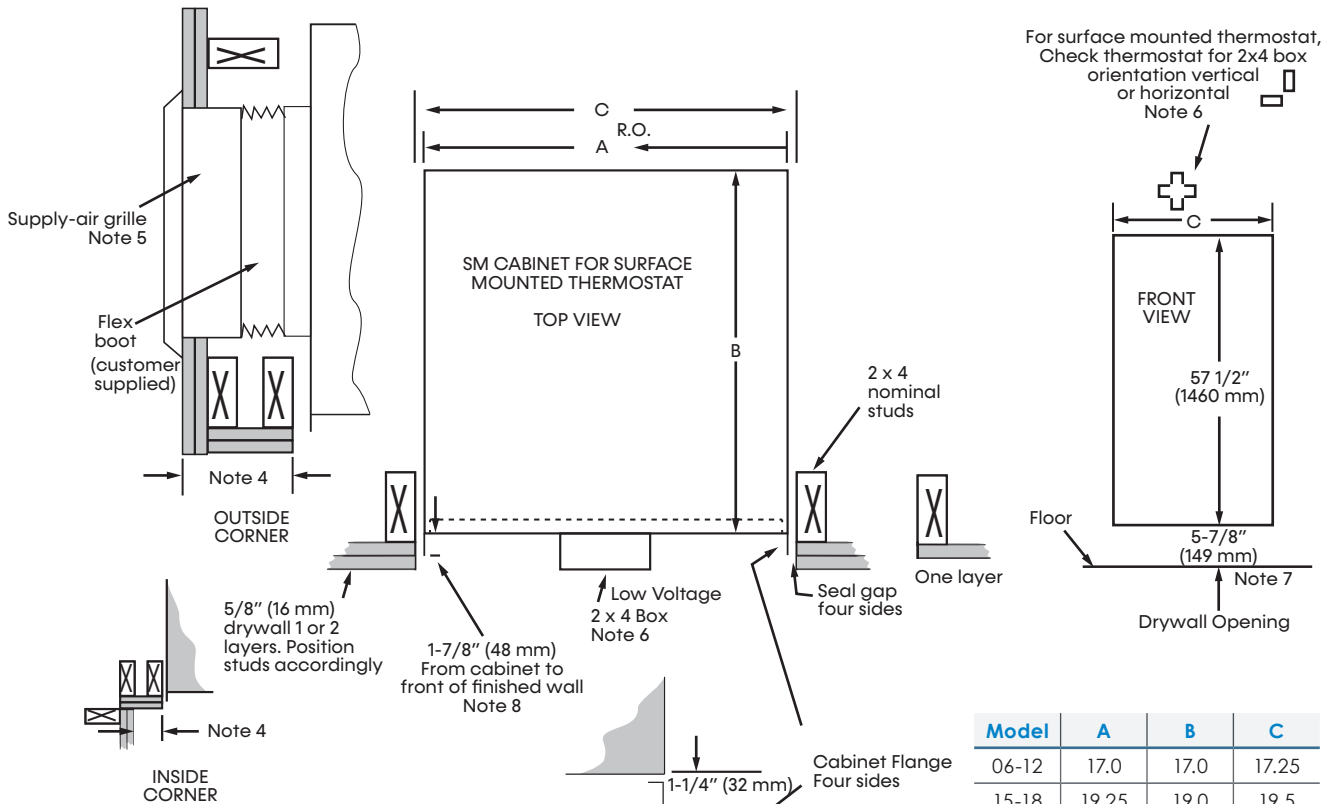

Model	A	B	C
06-12	17.0	17.0	17.25
15-18	19.25	19.0	19.5
24-36	24.25	24.0	24.5

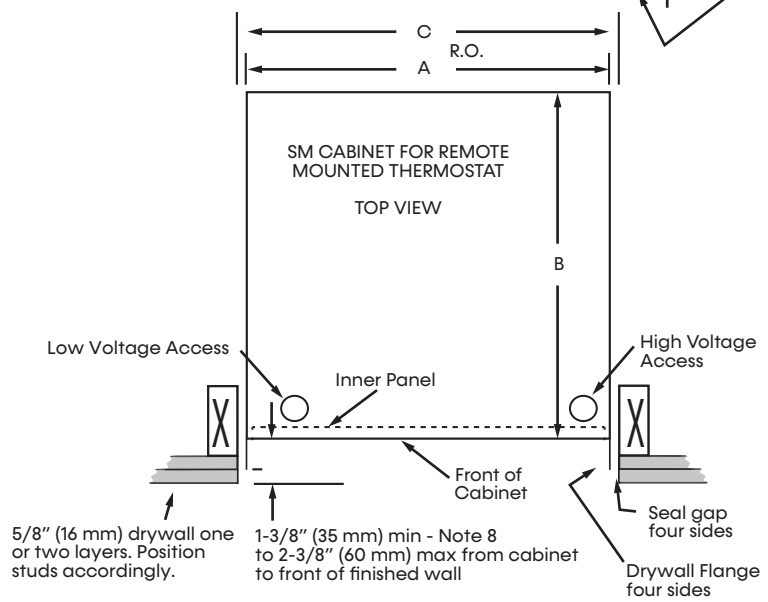

- Notes:
1. Dimensions shown are in inches and either mm or cm unless noted otherwise.
 2. Cabinet configuration determines slab-core drilling location and walls surrounding cabinet.
 3. The manufacturer recommends stud walls surrounding the cabinet. Drywall and studs should not be attached or contacting cabinet for best sound attenuation. Where possible fill gaps with sound-absorbing material. Use ISO pad under cabinet. Secure cabinet to floor in two places at back.
 4. Return-air G panel (not shown) overlaps rough opening, allow minimum of 3½-inches (89 mm) drywall to corner. Do not caulk panel to wall.
 5. If supply-air grille does not penetrate cabinet, connect with flex boot. Customer-supplied top duct should also connect with flex boot.
 6. Before installing drywall, contractor must turn box if needed. Horizontal is standard.
 7. If cabinet stand or ISO pad is used add to dimension.
 8. For 2-inches (50 mm) filter set cabinet 2-inches (50 mm) minimum from front of drywall.

NOTICE

Seal between studs and cabinet flanges with weather tight foam material to prevent wall cavity air from infiltrating unit or room.

Typical Cabinet with G Installation – Recessed

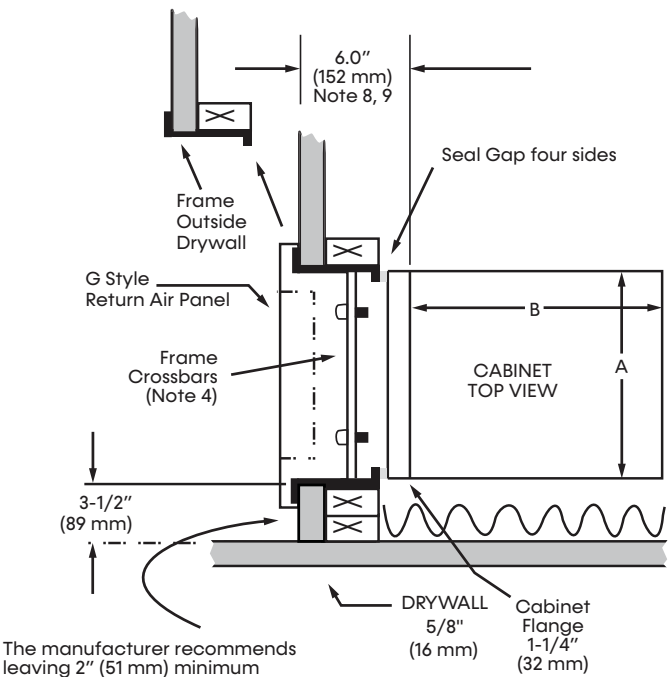

The manufacturer recommends leaving 2" (51 mm) minimum clearance on both sides for removing panel

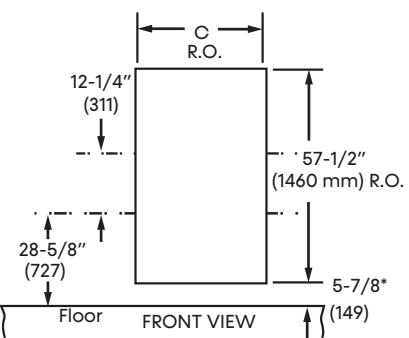
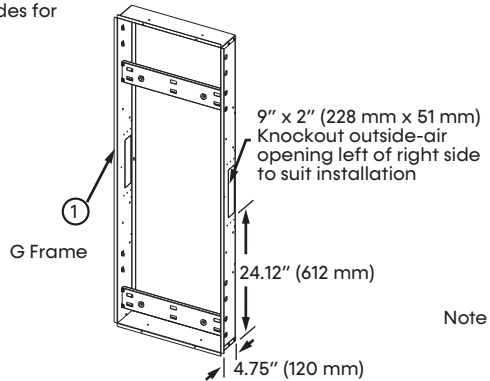

* Dimension if cabinet is on floor. Add if cabinet is on stand/pad.

NOTICE

- Recessed cabinet requires a frame kit.
- Outside air applications require a Motorized Damper or pre-treated air that is above 45°F (7°C) and below 95°F (35°C) dry bulb/75°F (24°C) wet bulb.
- Attach the frame to the wall studs, not the cabinet. Use weather seal material between the frame and cabinet to avoid bypass air being pulled in from the wall cavity.
- Do not distort frame. Shim the sides of the frame if required.

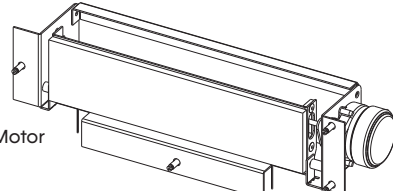

Optional Damper Motor

(Order separately)
Refer to the IOM packaged with the motorized damper assembly for installation instructions and note 7 (below) for its usage.

Kit Part	Qty	Description
1	1	Frame
2	2	Cross Bar

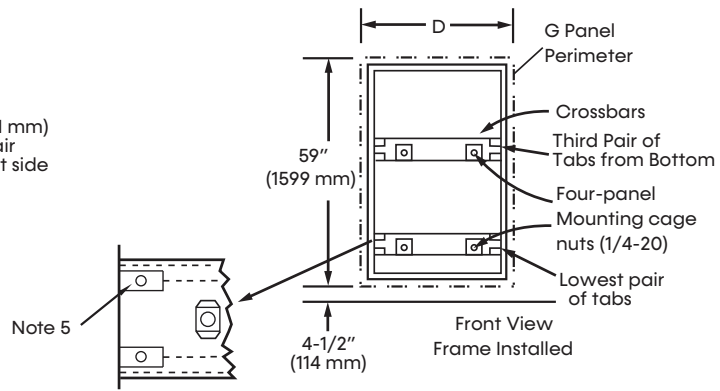

Kit	Size	Frame Kit in (mm)			Panel
		A	B	C	
48A0100N50	06-12	17.00 (432)	17.00 (432)	16.63 (400)	18.5 (470)
48A0100N51	15-18	19.25 (489)	19.00 (483)	19.63 (458)	21.5 (548)
48A0100N52	24-38	24.25 (816)	24.00 (610)	24.35 (620)	25.5 (648)

Notes:

1. The cabinet configuration determines the slab core-drilling location and the wall surrounding the cabinet.
2. Stud walls surrounding the cabinet are recommended. For better sound attenuation, the drywall studs should not be attached to or contacting the cabinet.
3. The G style return air panel overlaps its rough opening. Allow a minimum of 3½-inches (89 mm) of drywall to a corner. Do not caulk the return air panel to the wall.
4. The G panel attaches to the cross bars of the frame kit. The cabinet must be recessed behind the wall.
5. For air filter access, pivot the hinged inner panel and open the snapped filter access panel.
6. For chassis access:
 - a. Remove the entire G-Panel
 - b. Remove the (2x) cross bars of the frame kit
 - c. Remove the cabinet's filter panel
 - d. Slide out the chassis
7. When untreated outside air will be utilized, the 48A0100N04 motorized damper must be used. The mixed air temperature must be no lower than 45°F (7°C), must be no higher than 95°F (35°C) DB/75°F (35°C) WB, and must not exceed 20% of the cabinet's total CFM output.
8. For a 2-inch filter, set the cabinet 6¼-inches (158 mm) from the front of the dry wall.
9. If the four drywall flanges are removed, the cabinet can be set 1-inch (25 mm) closer to the finished drywall.
10. All dimensions are inches (mm) with all nominal 2 x 4 studs being 1.5-inches (38 mm) x 3.5-inches (89 mm).

Models:
SM
006-036

Drywall Openings

Figure 7: Cabinet Drywall Openings for Sizes 15-18 and G Panel on Floor

Figure 8: Cabinet Drywall Openings for Sizes 24-36 and G Panel with 8-inch Stand

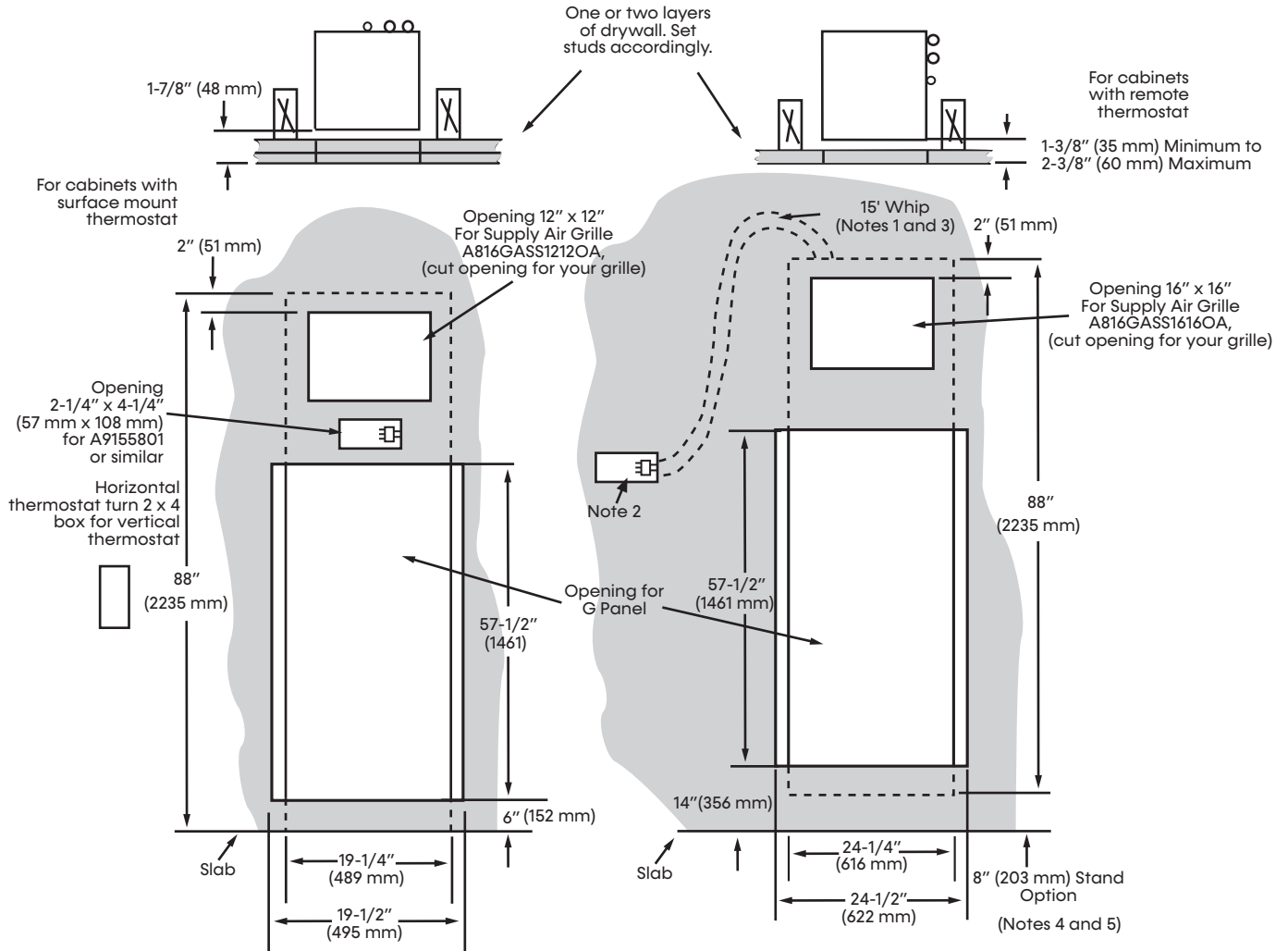

Notes:

1. All factory-installed whips end with 9-pin molex connector.
2. Field-supplied 2 x 4 box must be a type that the side can be removed so molex can be put inside. Position box horizontal or vertical for thermostat.
3. Optional 15-, 25-, or 35-foot whips (thermostat cable Class 2) available. Whips in BX armor available as special.
4. 1-inch to 13-inch (25 mm to 330 mm) stands are available. Stands are bulk shipped and must be field-installed.
5. When stands or ISO pads are used, ensure the riser length and position is calculated correctly (3-inches above and tailpiece always from bottom of cabinet). Stands or ISO pads raise add height.
6. For a 2-inch filter, set the cabinet 2 inches (50 mm) minimum from front of drywall.

NOTICE

Drywall openings shown above are for specific cabinets as indicated. Cut openings for your cabinet, supply air grille, and thermostat.

Drywall Openings

Figure 9: Cabinet Drywall Openings for 65-inch Cabinets and G Return-Air Panel

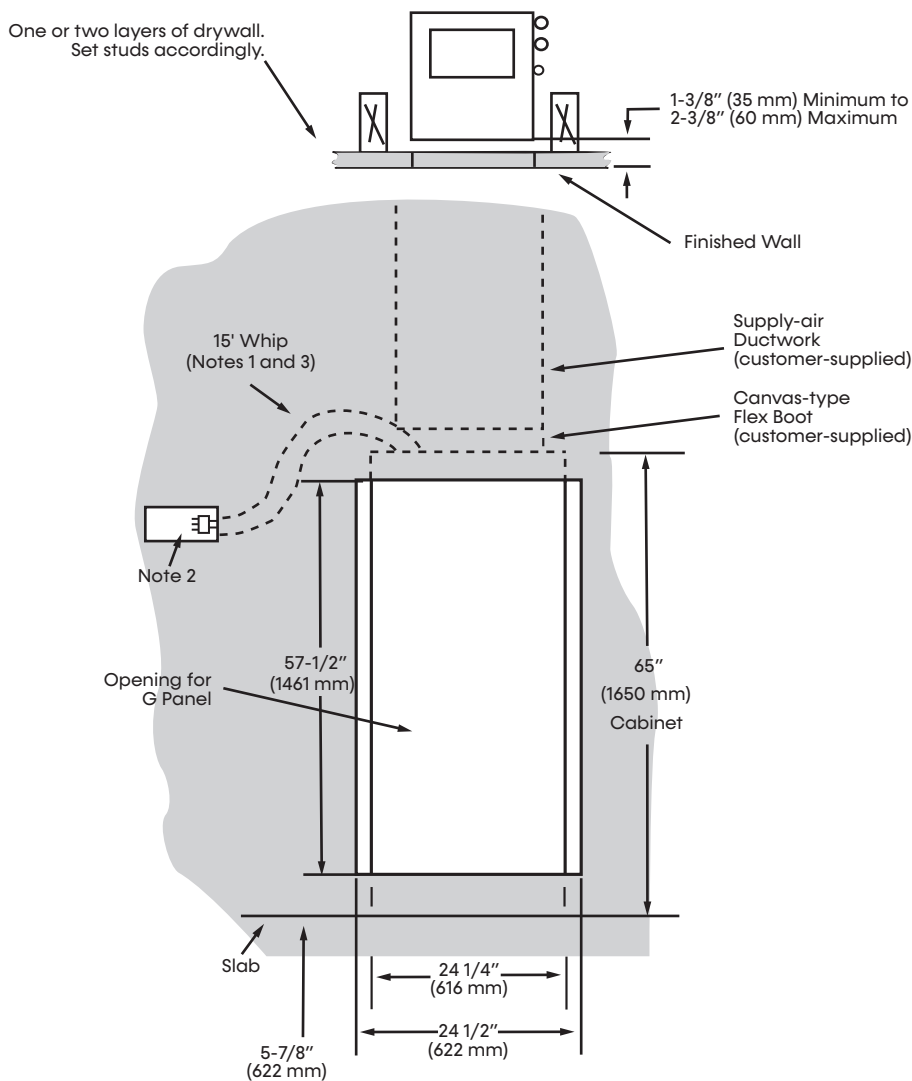

Notes:

- Optional factory-installed whips (Model Digit 3) end with 9-pin molex connector.
- Field-supplied 2 x 4 box must be a type that the side can be removed so molex can be put inside. Position box horizontal or vertical for thermostat.
- Optional 15-, 25-, or 35-foot whips (thermostat cable Class 2) available. Whips in BX armor available as special.
- 1-inch to 12-inch (25 mm to 305 mm) stands available, stands are bulk shipped and must be field-installed.
- When stands or ISO pads are used, make sure riser length and position is calculated correctly. 3-inches above and tailpiece always from bottom of cabinet. Stand or ISO pads raises everything up.
- For 2-inch filter, set cabinet 2-inches (50 mm) minimum from front of drywall.

NOTICE

Drywall openings shown below are for specific cabinets as indicated. Cut openings for your cabinet, supply air grille, and thermostat.

Models:
SM
006-036

Cabinet with G Panel Frame

Figure 10: Cabinet with G Panel Frame and Optional Outside Air Duct (Field Fabricated)

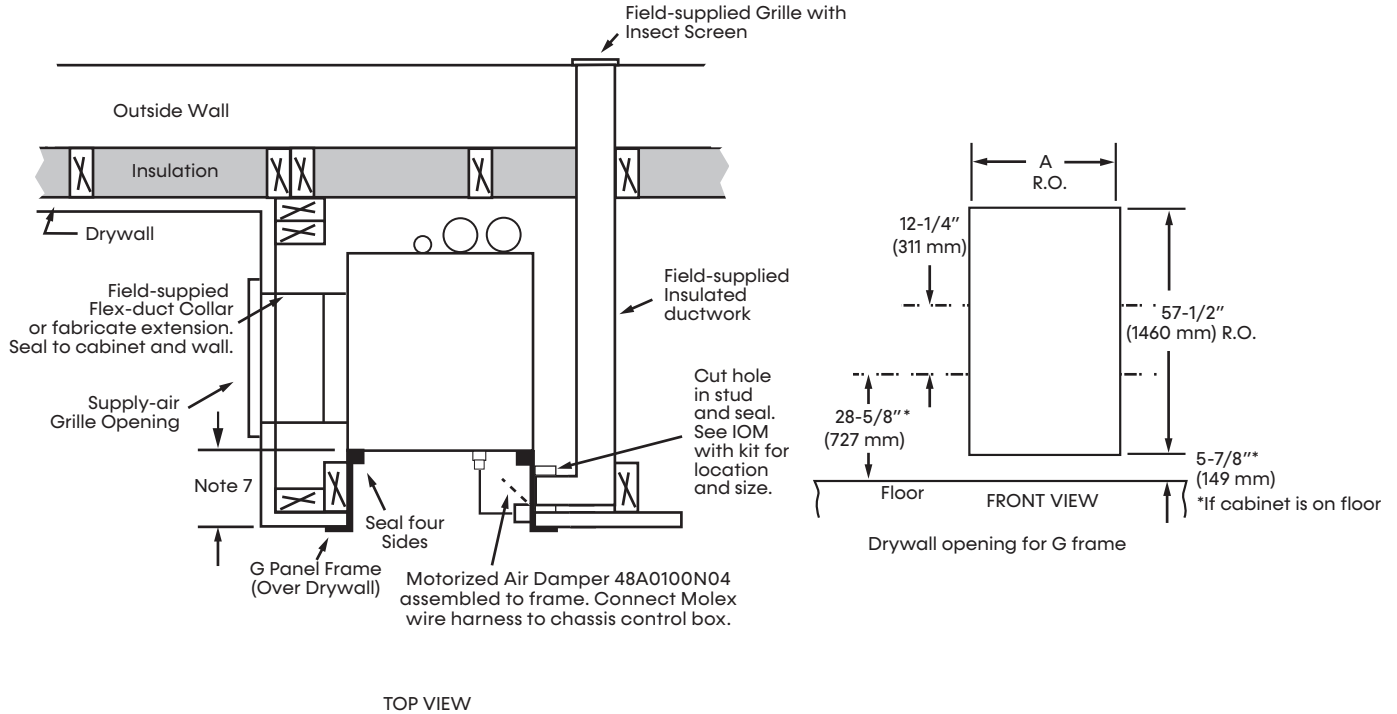

Notes:

1. All units with outside air option must use motorized air damper. Damper to be closed when unit not operating.
2. Duct can be on right or left side.
3. On all installations, mixed return air to unit must be 45°F (7°C) to 95°F (35°C), and not exceed 20% of total CFM.
4. On all installations, the ambient temperature behind interior wall must be above freezing.
5. Prevent condensate on all installations of risers and loop piping insulate if required.
6. Frame attaches to studs, do not distort shim if required.
7. Cabinets with 1-inch (25 mm) filter rack remove two side-cabinet flanges, set back 4¾-inches (121 mm) minimum; 2-inch (50 mm) filter rack set back 6¼-inches (159 mm) minimum.
8. Seal four sides between frame and cabinet. Use foam, foil tape, caulk, or field-fabricated sheet metal.

Models	Frame	A
06-12	48A0100N50	16-5/8" (400 mm)
15-18	48A0100N51	19-5/8" (498 mm)
24-38	48A0100N52	24-3/8" (620 mm)

Water-Loop Heat-Pump Applications

COMMERCIAL WATER LOOP APPLICATIONS

Commercial systems typically include a number of units connected to a common piping system. Any unit plumbing maintenance work can introduce air into the piping system; therefore air elimination equipment is a major portion of the mechanical room plumbing. Consideration should be given to insulating the piping surfaces to avoid condensation. ClimateMaster recommends piping insulation any time the water temperature is below 60°F (15.6°C). Metal to plastic threaded joints should never be used due to their tendency to leak over time.

Water thread sealant tape thread sealant is recommended to minimize internal fouling of the heat exchanger. Do not over tighten connections and route piping so as not to interfere with service or maintenance access. Hose kits are available from ClimateMaster in different configurations for connection between the unit and the piping system. Depending upon selection, hose kits may include shut off valves, P/T plugs for performance measurement, high pressure stainless steel braided hose, "Y" type strainer with blow down valve, and/or with blow down valve, auto-flow valve and swivel connections.

The piping system should be flushed to remove dirt, piping chips, and other foreign material prior to operation (see Piping System Cleaning and Flushing in this manual). The flow rate is usually set between 2.25 and 3.5 gpm per ton (2.9 and 4.5 l/m per kW) of cooling capacity. ClimateMaster recommends 3 gpm per ton (3.9 l/m per kW) for most water-loop heat pump applications. To ensure proper maintenance and servicing, P/T ports are imperative for temperature, flow verification, and performance checks.

Water-loop heat pump (cooling tower/boiler) systems typically utilize a common loop, maintained between 60 - 90°F (16 - 32°C). The use of a closed circuit evaporative cooling tower with a secondary heat exchanger between the tower and the water loop is recommended. If an open type cooling tower is used continuously, chemical treatment and filtering will be necessary.

Models:
SM
006-036

Ground-Loop Heat-Pump Applications

CAUTION

The following instructions represent industry accepted installation practices for closed loop earth coupled heat pump systems. Instructions are provided to assist the contractor in installing trouble free ground loops. These instructions are recommendations only. State/provincial and local codes MUST be followed and installation MUST conform to ALL applicable codes. It is the responsibility of the installing contractor to determine and comply with ALL applicable codes and regulations.

CAUTION

Ground loop applications require extended range equipment and optional refrigerant/water circuit insulation.

PRE-INSTALLATION

Prior to installation, locate and mark all existing underground utilities, piping, etc. Install loops for new construction before sidewalks, patios, driveways, and other construction has begun. During construction, accurately mark all ground loop piping on the plot plan as an aid in avoiding potential future damage to the installation.

PIPING INSTALLATION

All earth loop piping materials should be limited to polyethylene fusion only for in-ground sections of the loop. Galvanized or steel fittings should not be used at any time due to their tendency to corrode. All plastic to metal threaded fittings should be avoided due to their potential to leak in earth coupled applications. A flanged fitting should be substituted. P/T plugs should be used so that flow can be measured using the pressure drop of the unit heat exchanger.

Earth loop temperatures can range between 25 and 110°F [-4 to 43°C]. Flow rates between 2.25 and 3 GPM [2.41 to 3.23 l/m per kW] of cooling capacity is recommended in these applications.

Table 3: Antifreeze Percentages by Volume

Type	Minimum Antifreeze Concentration % for Low Temperature Protection			
	10°F [-12.2°C]	15°F [-9.4°C]	20°F [-6.7°C]	25°F [-3.9°C]
Methanol	25%	21%	16%	10%
100% USP food grade Propylene Glycol	38%	25%	22%	15%
Ethanol*	29%	25%	20%	14%

* Must not be denatured with any petroleum based product

Test individual horizontal loop circuits before backfilling. Test vertical U-bends and pond loop assemblies prior to installation. Pressures of at least 100 psi [689 kPa] should be used when testing. Do not exceed the pipe pressure rating. Test entire system when all loops are assembled.

FLUSHING THE EARTH LOOP

Upon completion of system installation and testing, flush the system to remove all foreign objects and purge to remove all air.

ANTIFREEZE

In areas where minimum entering loop temperatures drop below 40°F [5°C] or where piping will be routed through areas subject to freezing, antifreeze is required. Alcohols and glycols are commonly used as antifreeze; however your local sales office should be consulted to determine the antifreeze best suited to your area. Freeze protection should be maintained to 15°F [9°C] below the lowest expected entering loop temperature. For example, if 30°F [-1°C] is the minimum expected entering loop temperature, the leaving loop temperature would be 22 to 25°F [-6 to -4°C] and freeze protection should be at 15°F [-10°C].

Calculation is as follows:
 $30^{\circ}\text{F} - 15^{\circ}\text{F} = 15^{\circ}\text{F}$ [$-1^{\circ}\text{C} - 9^{\circ}\text{C} = -10^{\circ}\text{C}$].

All alcohols should be premixed and pumped from a reservoir outside of the building when possible or introduced under the water level to prevent fumes. Calculate the total volume of fluid in the piping system. Then use the percentage by volume shown in Table 3 below for the amount of antifreeze needed. Antifreeze concentration should be checked from a well mixed sample using a hydrometer or refractometer to measure specific gravity.

Water Quality Requirements

Table 4: Water Quality Requirements

Clean water is essential to the performance and life span of water source heat pumps. Contaminants, chemicals, and minerals all have the potential to cause damage to the water heat exchanger if not treated properly. All closed-loop water systems should undergo water quality testing and be maintained to the water quality standards listed in this table. All open-loop water systems shall be tested upon installation and periodically to ensure water quality standard in the table below are met.

Water Quality Requirements For Closed-Loop and Open-Loop Systems							
	Description	Symbol	Units	Heat Exchanger Type			
				Closed Loop Recirculating		Open Loop, Tower, Ground Source Well	
				All Heat Exchanger Types	Coaxial HX Copper Tube in Tube	Coaxial HX Cupronickel	Brazed- Plate HX 316 SS
Scaling Potential	pH - Chilled Water <85°F			7.0 to 9.0	7.0 to 9.0	7.0 to 9.0	7.0 to 9.0
	pH - Chilled Water >85°F			8.0 to 10.0	8.0 to 10.0	8.0 to 10.0	8.0 to 10.0
	Alkalinity	(HCO ₃ ⁻)	ppm - CaCO ₃ equivalent	50 to 500	50 to 500	50 to 500	50 to 500
	Calcium	(Ca)	ppm	<100	<100	<100	<100
	Magnesium	(Mg)	ppm	<100	<100	<100	<100
	Total Hardness	(CaCO ₃)	ppm - CaCO ₃ equivalent	30 to 150	150 to 450	150 to 450	150 to 450
	Langelier Saturation Index	LSI		-0.5 to +0.5	-0.5 to +0.5	-0.5 to +0.5	-0.5 to +0.5
Ryznar Stability Index	RSI		6.5 to 8.0	6.5 to 8.0	6.5 to 8.0	6.5 to 8.0	
Corrosion Prevention	Total Dissolved Solids	(TDS)	ppm - CaCO ₃ equivalent	<1000	<1000	<1000	<1000
	Sulfate	(SO ₄ ²⁻)	ppm	<200	<200	<200	<200
	Nitrate	(NO ₃ ⁻)	ppm	<100	<100	<100	<100
	Chlorine (free)	(Cl)	ppm	<0.5	<0.5	<0.5	<0.5
	Chloride (water < 80°F)	(Cl ⁻)	ppm	<20	<20	<150	<150
	Chloride (water > 120°F)	(Cl ⁻)	ppm	<20	<20	<125	<125
	Hydrogen Sulfide ^a	(H ₂ S)	ppb	<0.5	<0.5	<0.5	<0.5
	Carbon Dioxide	(CO ₂)	ppm	0	<50	10 to 50	10 to 50
	Iron Oxide	(Fe)	ppm	<1.0	<1.0	<1.0	<0.2
	Manganese	(Mn)	ppm	<0.4	<0.4	<0.4	<0.4
	Ammonia	(NH ₃)	ppm	<0.05	<0.1	<0.1	<0.1
	Chloramine	(NH ₂ CL)	ppm	0	0	0	0
Fouling & Biological	Iron bacteria		cells/mL	0	0	0	0
	Slime-forming bacteria		cells/mL	0	0	0	0
	Sulfate-reducing bacteria		cells/mL	0	0	0	0
	Suspended Solids ^b	(TSS)	ppm	<10	<10	<10	<10
Electrolysis All HX types	Earth Ground Resistance ^x		Ohms		Consult NEC and local electrical codes for grounding requirements		
	Electrolysis Voltage ^d		mV		Measure voltage and internal water loop to HP ground		
	Leakage Current ^e		mA		Measure current in water loop pipe		
	Building Primary Electrical Ground to unit, must meet local diameter and penetration length requirements. Do not connect heat pump to steel pipe unless dissimilar materials are separated by using DI-electric unions. Galvanic corrosion of heat pump water pipe will occur						

Models:
SM
006-036

Water Quality Requirements

1. The ClimateMaster Water Quality Table on page 39 provides water quality requirements for coaxial and brazed plate heat exchangers.
2. The water must be evaluated by an independent testing facility comparing site samples against this Water Quality Table. When water properties are outside of these parameters, the water must either be treated by a professional water treatment specialist to bring the water quality within the boundaries of this specification, or an external secondary heat exchanger must be used to isolate the heat pump water system from the unsuitable water. Failure to do so will void the warranty of the heat pump system and will limit liability for damage caused by leaks or system failure.
3. Regular sampling, testing and treatment of the water is necessary to assure that the water quality remains within acceptable levels thereby allowing the heat pump to operate at optimum levels.
4. If closed-loop systems are turned off for extended periods, water samples must be tested prior to operating the system.
5. For optimal performance, it is recommended that the closed-loop piping systems are initially filled with de-ionized water.
6. Well water with chemistry outside of these boundaries, and salt water or brackish water requires an external secondary heat exchanger. Surface/Pond water should not be used.
7. If water temperature is expected to fall below 40°F (4.4°C), antifreeze is required. Refer to the heat pump IOM for the correct solution ratios to prevent freezing.
 - α Hydrogen Sulfide has an odor of rotten eggs. If one detects this smell, a test for H₂S must be performed. If H₂S is detected above the limit indicated, remediation is necessary (Consult with your Water Testing/Treatment Professional) or a secondary heat exchanger is required using appropriate materials as recommended by the heat exchanger supplier.
 - β Suspended solids and particulates must be filtered to prevent fouling and failure of heat exchangers. Strainers or particulate filters must be installed to provide a maximum particle size of 600 micron (0.60 mm, 0.023 inch) using a 20 to 30 mesh screen size. When a loop is installed in areas with fine material such as sand or clay, further filtration is required to a maximum of 100 micron. Refer to the Strainer / Filter Sizing Chart to capture the particle sizes encountered on the site.
 - χ The WSHP piping system or other plumbing pipes must not be used as the building ground. An electrical grounding system using a dedicated ground rod meeting NEC and local electrical codes must be installed.
 - δ Refer to Table 3 on page 38 for instructions on measuring resistance and leakage currents within water loops.

Strainer / Filter Sizing

Mesh Size	Particle Size		
	Microns	MM	Inch
20	840	0.840	0.0340
30	533	0.533	0.0210
60	250	0.250	0.0100
100	149	0.149	0.0060
150	100	0.100	0.0040
200	74	0.074	0.0029

ppm = parts per million
ppb = parts per billion

Water Quality Requirements

Models:
SM
006-036

Measuring Earth Ground Resistance for Ground-Water Applications

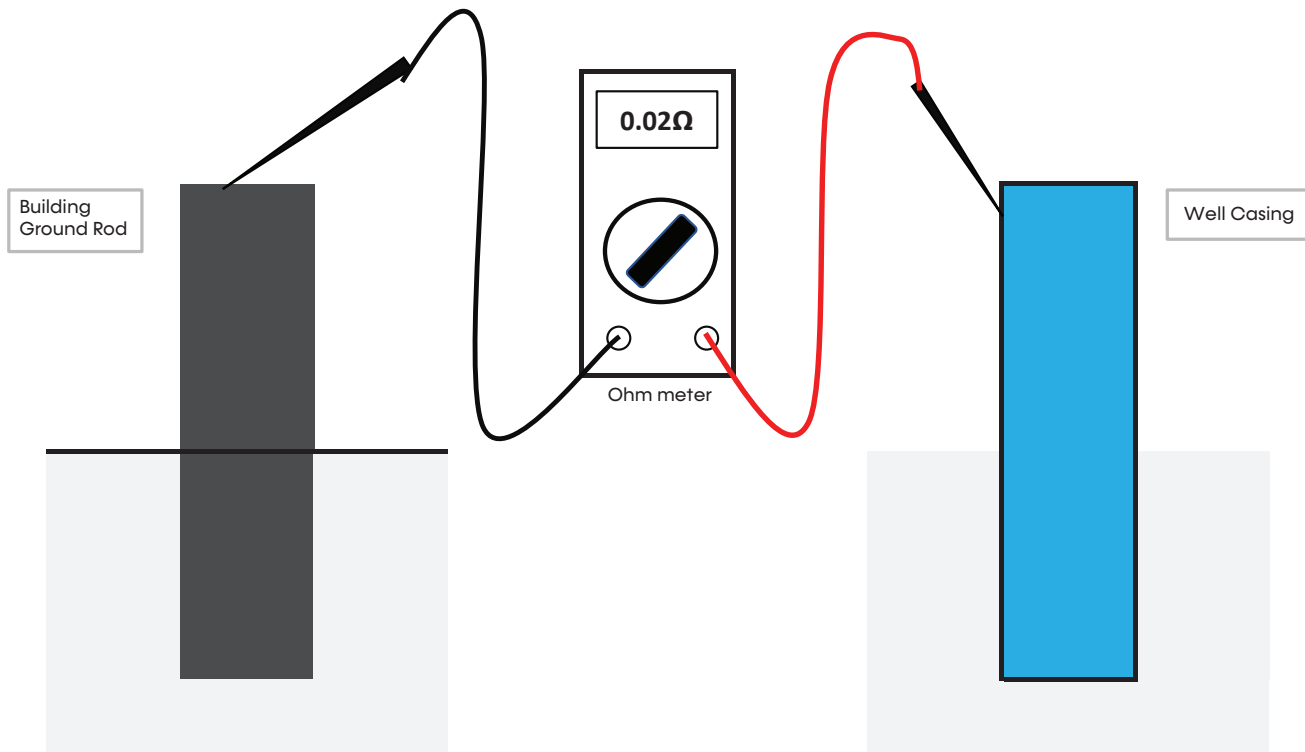

Measure the earth ground bond using an Ohm meter between the building's ground rod and the steel well casing.

The resistance measured should be zero Ohms. The NEC allows a resistance to ground up to 20 Ohms. Any resistance above zero indicates a poor earth ground, which may be the result of a hot neutral line or that conductive water is present. Both of these may lead to electrolysis and corrosion of the heat pump piping. A check for both should be performed and resolved.

NOTE: If the well casing is plastic, a conductive path can be achieved by inserting a #6 AWG bare copper wire into the well water. Remove the temporary conductor when finished.

Models:
SM
006-036

Water Quality Requirements

Measuring Electrolysis, Voltage, and Current for Ground-Water Applications

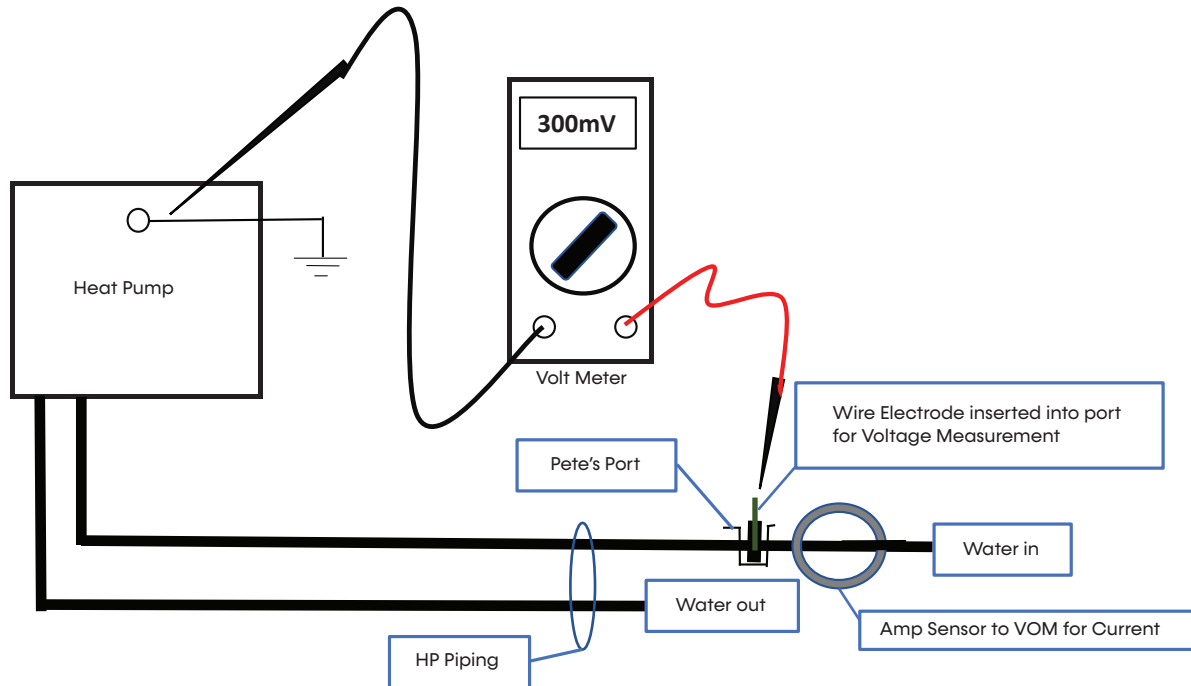

Measure the electrolysis voltage using a volt meter between the heat pump ground and a #14 AWG solid copper wire electrode inserted into the water using a Pete's style access port.

The heat pump must be operating and the water stream flowing.

The voltage measured should be less than 300mV (0.300V). If the voltage is higher than 500mV, electrolysis will occur and corrosion will result.

If voltage is measured, the cause is a high-resistance earth ground or current on the neutral conductor. Remedial measures should be performed.

Measure the current flowing through the piping system by using an amp clamp probe on the water-in line. The heat pump must be operating and the water stream flowing.

There should be zero amps measured. If current is present, there is leakage current to the plumbing system and it must be rectified to prevent pipe corrosion.

SMS Electrical Data (CV) EC Blower Motor

Models:
SM
006-036

(CV) EC Blower Motor (208/230V)

Model	Voltage Code G	Compressor		Blower Motor	Pump Option	Total Unit FLA	Min Circuit Amps	Max Fuse Amps
		RLA	LRA	FLA	FLA			
SMS06	208/230-60-1	3.8	27	1.5	0.0	5.3	6.2	15
					0.6			
SMS09		5.2	27	1.5	0.0	6.7	8.0	15
					0.6			
SMS12		6.7	27	1.5	0.0	8.2	9.9	15
					0.6			
SMS15		10.6	35	2.6	0.0	13.2	15.9	15
					0.6			
SMS18		13.3	35	2.6	0.0	15.9	19.2	15
					0.6			
SMS24		11.4	64.4	2.6	0.0	14.0	18.6	30
					0.6			
SMS30		12.7	75.6	3.9	0.0	16.6	19.9	30
					0.6			
SMS36		14.4	86	3.9	0.0	18.3	21.5	35
					0.6			

(CV) EC Blower Motor (265V)

Model	Voltage Code E	Compressor		Blower Motor	Pump Option	Total Unit FLA	Min Circuit Amps	Max Fuse Amps
		RLA	LRA	FLA	FLA			
SMS06	265-60-1	2.5	22	1.4	0.0	3.9	4.5	15
					0.6			
SMS09		5.2	27	1.4	0.0	4.9	5.8	15
					0.6			
SMS12		6.7	27	1.4	0.0	6.0	7.2	15
					0.6			
SMS15		10.6	35	2.1	0.0	7.6	9.0	15
					0.6			
SMS18		13.3	35	2.1	0.0	8.6	10.2	15
					0.6			
SMS24		11.4	64.4	2.1	0.0	11.7	14.1	20
					0.6			
SMS30		12.7	75.6	3.2	0.0	14.1	16.8	25
					0.6			
SMS36		14.4	86	3.2	0.0	15.4	18.5	30
					0.6			

Models:
SM
006-036

SMS Electrical Data (CT) EC Blower Motor

(CT) EC Blower Motor (208/230V)

Model	Voltage Code G	Compressor		Blower Motor	Pump Option	Total Unit FLA	Min Circuit Amps	Max Fuse Amps
		RLA	LRA	FLA	FLA			
SMS06	208/230-60-1	3.8	27	2.3	0.0	6.1	7.0	15
					0.6			
SMS09		5.2	27	2.3	0.0	7.5	8.8	15
					0.6			
SMS12		6.7	27	2.3	0.0	9.0	10.7	15
					0.6			
SMS15		10.6	35	2.5	0.0	13.1	15.8	15
					0.6			
SMS18		13.3	35	2.5	0.0	15.8	19.1	15
					0.6			
SMS24		11.4	64.4	4.3	0.0	15.7	20.3	30
					0.6			
SMS30		12.7	75.6	4.3	0.0	17.0	20.3	30
					0.6			
SMS36	14.4	86	6.1	0.0	20.5	23.7	35	
				0.6				21.1

(CT) EC Blower Motor (265V)

Model	Voltage Code E	Compressor		Blower Motor	Pump Option	Total Unit FLA	Min Circuit Amps	Max Fuse Amps
		RLA	LRA	FLA	FLA			
SMS06	265-60-1	2.5	22	2.3	0.0	4.8	5.4	15
					0.6			
SMS09		5.2	27	2.3	0.0	7.5	8.8	15
					0.6			
SMS12		6.7	27	2.3	0.0	9.0	10.7	15
					0.6			
SMS15		10.6	35	2.5	0.0	13.1	15.8	15
					0.6			
SMS18		13.3	35	2.5	0.0	15.8	19.1	15
					0.6			
SMS24		11.4	64.4	4.3	0.0	13.9	16.3	25
					0.6			
SMS30		12.7	75.6	4.3	0.0	15.2	17.9	25
					0.6			
SMS36	14.4	86	6.1	0.0	18.3	21.4	30	
				0.6				18.9

SMT Electrical Data (CV) EC Blower Motor

Models:
SM
006-036

(CV) EC Blower Motor (208/230V)

Model	Voltage Code G	Compressor		Blower Motor	Pump Option	Total Unit FLA	Min Circuit Amps	Max Fuse Amps
		RLA	LRA	FLA	FLA			
SMT06	208/230-60-1	3.8	27	1.5	0.0	5.3	6.2	15
					0.6			
SMT09		5.2	27	1.5	0.0	6.7	8.0	15
					0.6			
SMT12		6.7	27	1.5	0.0	8.2	9.9	15
					0.6			
SMT15		10.6	35	2.6	0.0	13.2	15.9	15
					0.6			
SMT18		13.3	35	2.6	0.0	15.9	19.2	15
					0.6			
SMT24		11.4	64.4	2.6	0.0	14.0	20.3	30
					0.6			
SMT30		12.7	75.6	3.9	0.0	16.6	20.3	30
					0.6			
SMT36		14.4	86	4.7	0.0	19.1	23.7	35
					0.6			

(CV) EC Blower Motor (265V)

Model	Voltage Code E	Compressor		Blower Motor	Pump Option	Total Unit FLA	Min Circuit Amps	Max Fuse Amps
		RLA	LRA	FLA	FLA			
SMT06	265-60-1	2.5	22	1.4	0.0	5.2	6.1	15
					0.6			
SMT09		5.2	27	1.4	0.0	6.6	7.9	15
					0.6			
SMT12		6.7	27	1.4	0.0	8.1	9.8	15
					0.6			
SMT15		10.6	35	2.1	0.0	12.7	15.4	15
					0.6			
SMT18		13.3	35	2.1	0.0	15.4	18.7	15
					0.6			
SMT24		9.6	54	2.1	0.0	13.5	20.3	20
					0.6			
SMT30		10.9	60	3.2	0.0	15.9	20.3	25
					0.6			
SMT36		12.2	72	4.7	0.0	19.1	23.7	30
					0.6			

Models:
SM
006-036

SMT Electrical Data (CT) EC Blower Motor

(CT) EC Blower Motor (208/230V)

Model	Voltage Code G	Compressor		Blower Motor	Pump Option	Total Unit FLA	Min Circuit Amps	Max Fuse Amps
		RLA	LRA	FLA	FLA			
SMT06	208/230-60-1	3.8	27	2.3	0.0	5.3	6.2	15
					0.6			
SMT09		5.2	27	2.3	0.0	6.0	6.9	15
					0.6			
SMT12		6.7	27	2.3	0.0	6.9	8.1	15
					0.6			
SMT15		10.6	35	2.5	0.0	8.1	9.5	15
					0.6			
SMT18		13.3	35	2.5	0.0	9.1	10.8	15
					0.6			
SMT24		11.4	64.4	4.3	0.0	17.1	20.3	30
					0.6			
SMT30		12.7	75.6	4.3	0.0	17.1	20.3	30
					0.6			
SMT36		14.4	86	6.1	0.0	20.2	23.7	35
					0.6			

(CT) EC Blower Motor (265V)

Model	Voltage Code E	Compressor		Blower Motor	Pump Option	Total Unit FLA	Min Circuit Amps	Max Fuse Amps
		RLA	LRA	FLA	FLA			
SMT06	265-60-1	2.5	22	2.3	0.0	4.8	5.4	15
					0.6			
SMT09		5.2	27	2.3	0.0	5.8	6.7	15
					0.6			
SMT12		6.7	27	2.3	0.0	6.2	7.1	15
					0.6			
SMT15		10.6	35	2.5	0.0	7.5	8.8	15
					0.6			
SMT18		13.3	35	2.5	0.0	8.1	9.5	15
					0.6			
SMT24		9.6	54	4.3	0.0	13.9	16.3	25
					0.6			
SMT30		10.9	60	4.3	0.0	15.2	17.9	25
					0.6			
SMT36		12.2	72	6.1	0.0	18.3	21.4	30
					0.6			

Electrical: Power Wiring

⚠ WARNING

Disconnect electrical power source to prevent injury or death from electrical shock.

⚠ CAUTION

Use only copper conductors for field installed electrical wiring. Unit terminals are not designed to accept other types of conductors.

ELECTRICAL

Line Voltage - All field installed wiring, including electrical ground, must comply with NFPA 70: National Electrical Code (NEC), CSA C22.1: Canadian Electrical Code (CE Code), as well as applicable local codes. Refer to the unit electrical data for fuse sizes. Consult wiring diagram for field connections that must be made by the installing (or electrical) contractor. All final electrical connections must be made with a length of flexible conduit to minimize vibration and sound transmission to the building.

GENERAL LINE VOLTAGE WIRING

Be sure the available power is the same voltage and phase shown on the unit serial plate. Line and low voltage wiring must be done in accordance with local codes or the National Electric Code, whichever is applicable.

Figure 11: Single Phase Line Voltage Field Wiring

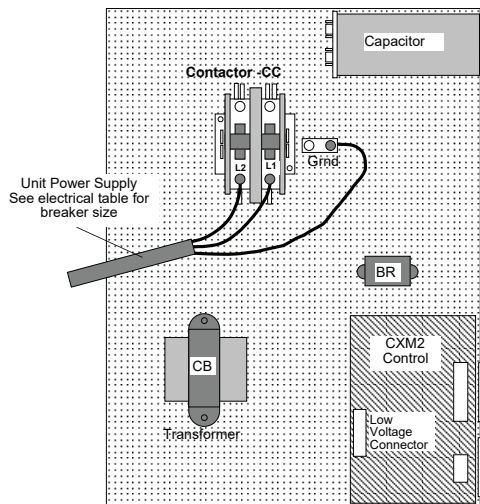

NOTE: 460V units with an EC motor or Internal Secondary Pump require a neutral wire. Three-phase wiring is similar except that all three power wires are directly connected to the contactor.

POWER CONNECTION

Line voltage connection is made by connecting the incoming line voltage wires to the “L” side of the contactor as shown in Figure 12. Consult electrical data tables for maximum fuse size.

TRANSFORMER

All 208/230V units are factory wired for 208V. If supply voltage is 230V, installer must rewire transformer. See wiring diagram for connections.

BLOWER SPEED SELECTION: UNITS WITH (CV) EC BLOWER MOTOR

Change CFM from default settings by using a communicating thermostat or service tool with a vertical-stack service harness. Use information in Table 5 to set CFM for your static.

Models:
SM
006-036

Electrical: CXM2 Example Wiring Diagram

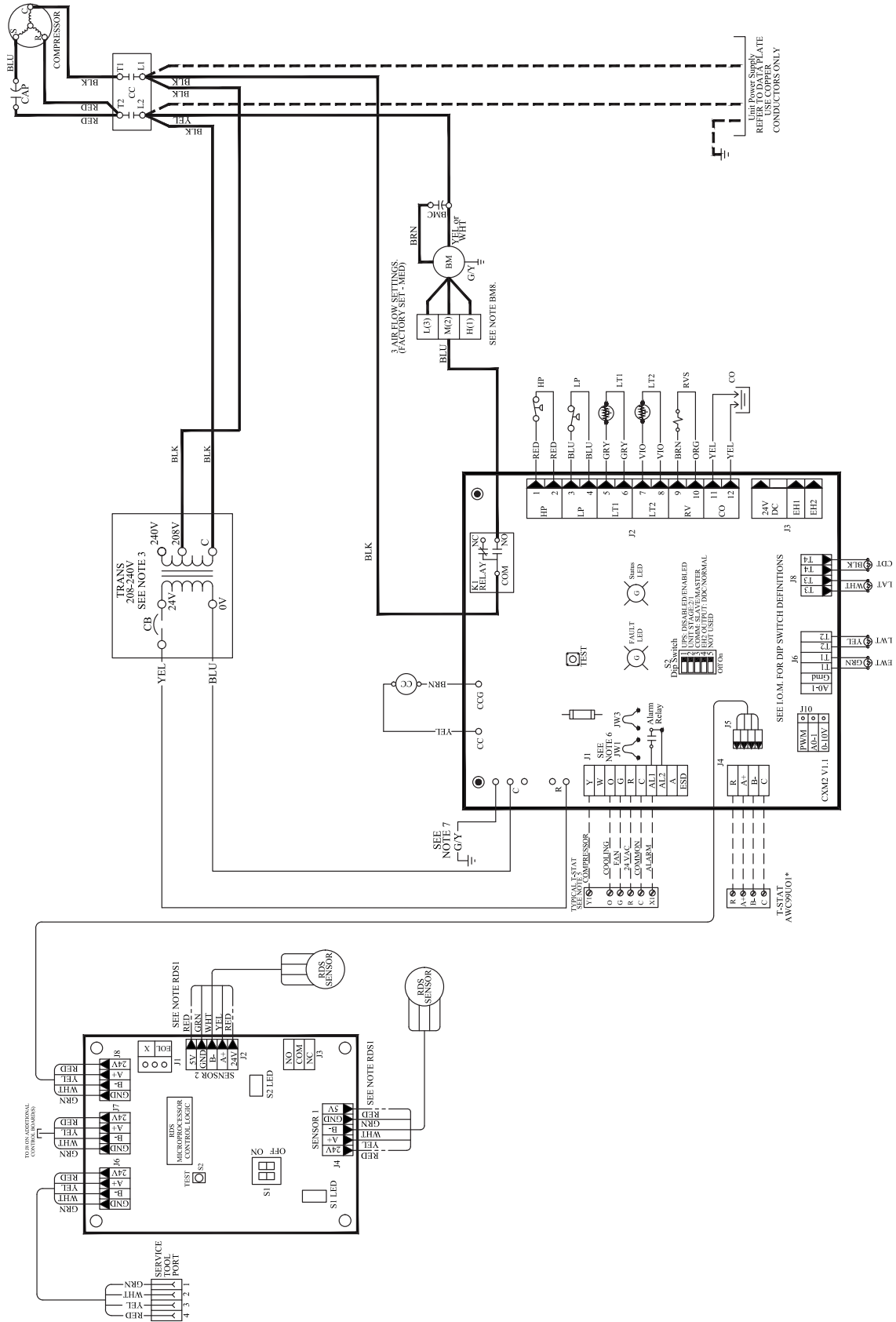

Electrical: Low Voltage Wiring

THERMOSTAT CONNECTIONS

The thermostat should be wired directly to the CXM2 or DXM2.5 board. See Electrical: Thermostat Wiring for specific terminal connections. Review the appropriate AOM (Application, Operation and Maintenance) manual for units with DDC controls.

WALL SENSORS (ASW) FOR MPC

Connections are made to DDC controller, see the Wire Diagram. Cabinets with MPC requires field to clip JW1 jumper on CXM2 or DXM2.5 board in chassis (chassis model digit 9 is N or P and cabinet model digit 9 is 2 or D).

LOW WATER TEMPERATURE CUTOUT SELECTION

The CXM2/DXM2.5 control allows the field selection of low water (or water-antifreeze solution) temperature limit by clipping jumper JW3 (see Figure 12 below), which changes the sensing temperature associated with thermistor LT1. Note that the LT1 thermistor is located on the refrigerant line between the coaxial heat exchanger and expansion device (TXV).

Therefore, LT1 is sensing refrigerant temperature, not water temperature, which is a better indication of how water flow rate/temperature is affecting the refrigeration circuit.

The factory setting for LT1 is for systems using water (30°F [-1.1°C] refrigerant temperature). In low water temperature (extended range) applications with antifreeze (most ground loops), jumper JW3 should be clipped as shown in the Figure 12 below to change the setting to 10°F [-12.2°C] refrigerant temperature, a more suitable temperature when using an antifreeze solution. All ClimateMaster units operating with entering water temperatures below 60°F [15.6°C] must include the optional water/ refrigerant circuit insulation package to prevent internal condensation.

Figure 12: LT1 Limit Setting

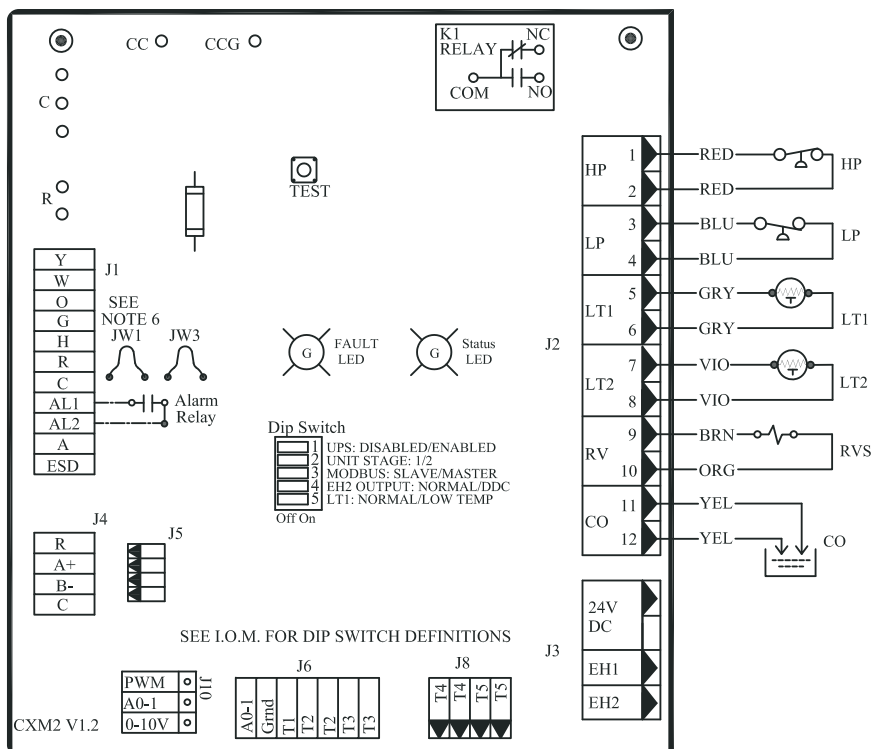

Models:
SM
006-036

Electrical: Low Voltage Wiring

TEMPERATURE SENSORS

Six temperature sensors are located on the chassis:

1. Entering water temperature
2. Leaving water temperature
3. Leaving air temperature
4. Water coil (LT1) temperature
5. Air coil (LT2) temperature
6. Compressor discharge temperature

The temperatures at these points can be viewed by the AWC communicating thermostat or directly at the unit with an ACD diagnostic tool. See the images on this page for details on the placement of the sensors.

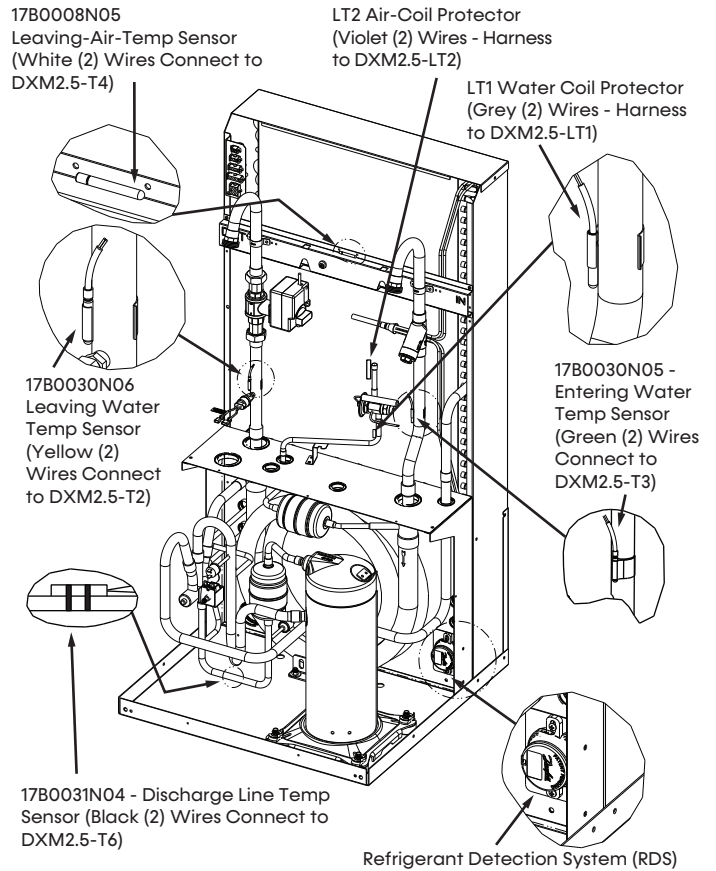
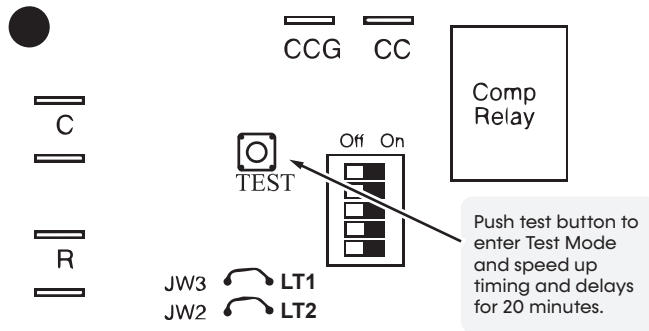

Electrical: Low Voltage Wiring

REFRIGERANT DETECTION SYSTEM (RDS)

The function, operation, and required servicing measures for the Refrigerant Detection System (RDS) include the following:

- The RDS monitors the status of the refrigerant sensor(s) in the unit. If refrigerant is detected above the maximum threshold, the control enables the unit blower, disables the compressor(s), and enables the pilot relay on the RDS control board. You can use this relay to open external zoning dampers and/or activate external mechanical ventilation. The relay is normally closed (NC) and can control a signal with a maximum of 28VA @ 24VAC.
- A fault is enabled if the RDS control board loses communication with a refrigerant sensor or if the main control board loses communication with the RDS board. See Functional Troubleshooting for steps to troubleshoot the RDS.

Figure 13: RDS Board

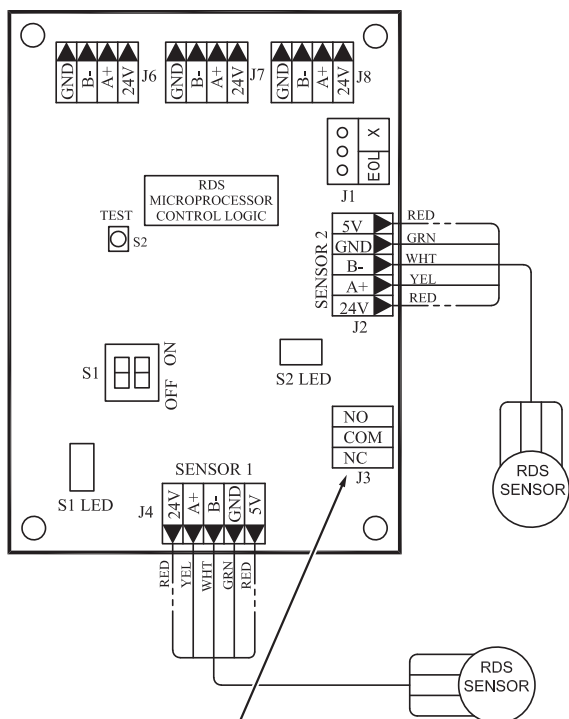

NOTE: Connect mitigation measures to the J3 jumper.

FIELD-INSTALLED RDS SYSTEM

For horizontal systems installed on ceiling plenum for non-ducted applications, use the following guidelines to install a refrigerant detection sensor upstream of the return of the unit:

1. The sensor must be located within 3 inches of the unit
2. The sensor must be on the same plane or lower than the unit

NOTICE

The sensor cannot be installed in a way that exposes it to water and must be installed using the orientation displayed in the figure below.

Figure 14: RDS Installation

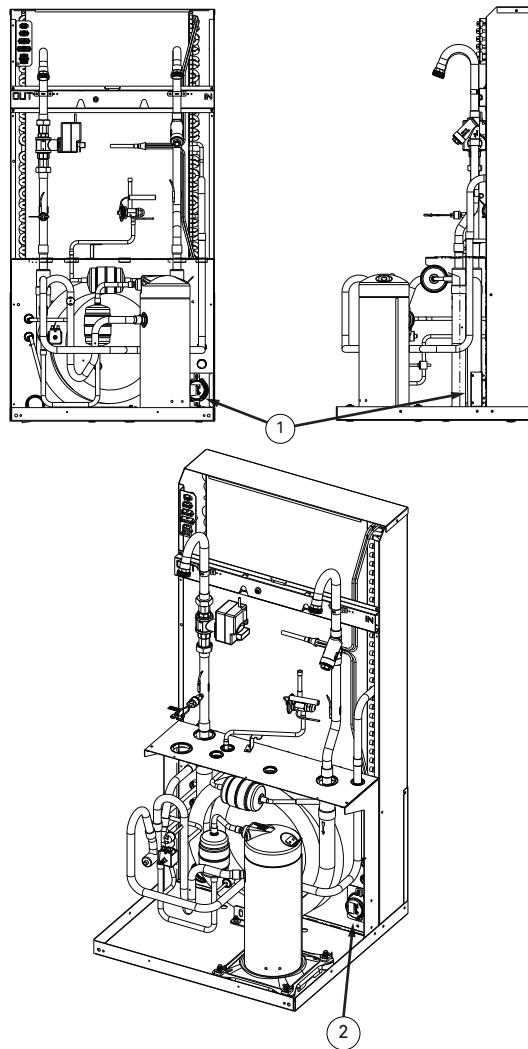

Models:
SM
006-036

Electrical: Thermostat

THERMOSTAT INSTALLATION

Installation of Optional Wall-Mounted Thermostat
 - The unit can be furnished with a 24V surface-mounted ACO or MCO control circuit or a remote 24V ACO or MCO thermostat. A typical field connection diagram is shown in Figure 15. A communicating thermostat connection to ClimateMaster's AWC communicating thermostat is shown in Figure 16. Refer to instructions provided with remote thermostat for wiring instructions.

Low-voltage wiring between the unit and the wall thermostat must comply with all applicable electrical codes (i.e., NEC and local codes), and be completed before the unit is installed. Use of eight wire, color-coded, low-voltage cable is recommended.

NOTE: Your thermostat may require fewer than eight connections. Eight wires enable you to upgrade the thermostat. Tape off unused wires.

Figure 15: Typical Field Connection for Units with Wall-Mounted 24V Thermostat

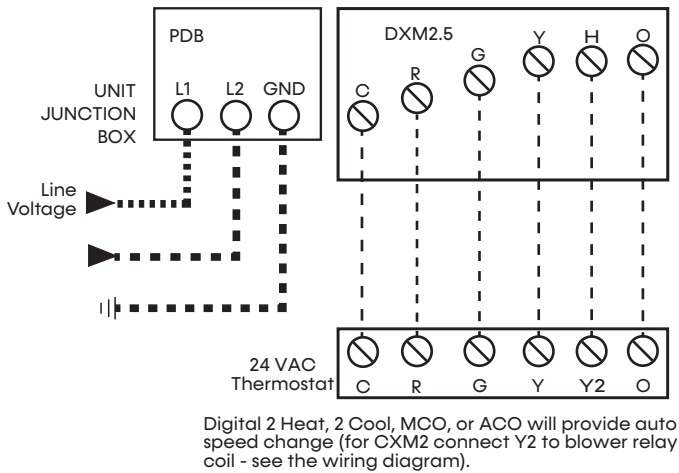

WARNING
 Disconnect electrical power source to prevent injury or death from electrical shock.

CAUTION
 Use copper conductors only to prevent equipment damage

WARNING
 Zone integrity must be maintained to efficiently control units or groups of units. Unless zones of control are considered and accounted for, adjacent units may operate in heating and cooling modes simultaneously.

The table below lists recommended wire sizes and lengths to install the thermostat. The total resistance of low-voltage wiring must not exceed 1 ohm. Any resistance in excess of 1 ohm may cause the control to malfunction because of high voltage drop.

A91558 Series thermostats have a 6-inch (152 mm) pigtail ending with 9-pin Molex. This allows an easy connection to either surface mount or remote with factory-whip option.

Table 5: Recommended Thermostat Wire Sizes

WIRE SIZE	MAX. WIRE LENGTH
22-Gauge	30 Feet
20-Gauge	50 Feet
18-Gauge	75 Feet
16-Gauge	125 Feet
14-Gauge	200 Feet

Figure 16: Communicating Thermostat to DXM2.5

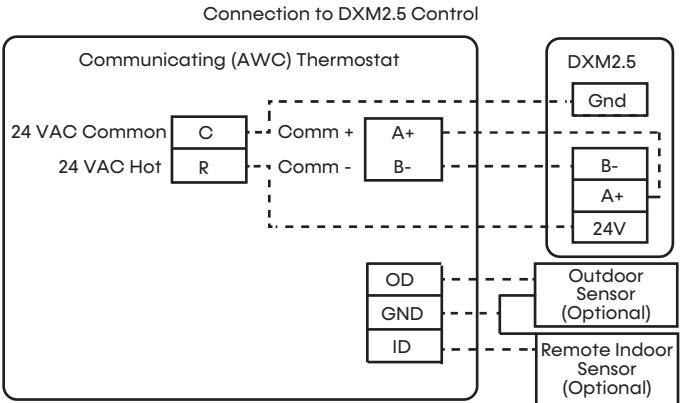

Blower Performance SMS06

Models:
SM
006-036

Blower Motor	Blower Motor Details		External Static Pressure (in. wg)			
			0.0	0.1	0.2	0.3
(CV) EC	CFM		0.0	0.1	0.2	0.3
	150	RPM	408	498	576	672
	200	RPM	544	664	768	896
	250	RPM	680	830	960	1120
	300	RPM	780	920	1060	1200
	350	RPM	890	1020	1160	1280
	400	RPM	990	1110	1240	1340

Blower performance data is based on the lowest nameplate voltage setting.
 Blower performance is based on a wet coil with clean 1-inch filter.
 Blower performance is based on operating conditions of 80°F DB and 67°F WB.
 CFM Tolerance is ±7%.
 RPM/Watt tolerance is ±10%.
 Cells in grey - option not available.

Models:
SM
006-036

Blower Performance SMS09

Blower Motor	Blower Motor Details		External Static Pressure (in. wg)								
	Speed Tap		0.0	0.1	0.2	0.3					
(CT) EC	1	RPM	680								
		Power (W)	20								
		CFM	250								
	2	RPM	760				870				
		Power (W)	27				30				
		CFM	290				270				
	3	RPM	930				1000			1100	1180
		Power (W)	43				47			51	54
		CFM	370				340			320	290
	4	RPM	1010				1070			1160	1240
		Power (W)	54				58			62	66
		CFM	410				380			360	330
(CV) EC	CFM		0.0	0.1	0.2	0.3					
	250	RPM	680	830	960	1120					
		Power (W)	22	30	38	47					
	300	RPM	780	920	1060	1200					
		Power (W)	29	38	48	58					
	350	RPM	890	1020	1160	1280					
		Power (W)	40	50	62	73					
	400	RPM	990	1110	1240	1340					
		Power (W)	52	65	79	92					

Blower performance data is based on the lowest nameplate voltage setting.
 Blower performance is based on a wet coil with clean 1-inch filter.
 Blower performance is based on operating conditions of 80°F DB and 67°F WB.
 CFM Tolerance is ±7%.
 RPM/Watt tolerance is ±10%.
 Cells in grey - option not available.

Blower Performance SMS12

Models:
SM
006-036

Blower Motor	Blower Motor Details		External Static Pressure (in. wg)			
	Speed Tap		0.0	0.1	0.2	0.3
(CT) EC	1	RPM	800			
		Power (W)	29			
		CFM	320			
	2	RPM	870	960	1050	
		Power (W)	40	44	48	
		CFM	360	340	310	
	3	RPM	960	1040	1130	1220
		Power (W)	59	63	67	71
		CFM	410	390	370	350
	4	RPM	1030	1110	1190	1280
		Power (W)	78	82	87	91
		CFM	450	430	420	400
(CV) EC	CFM		0.0	0.1	0.2	0.3
	300	RPM	760	890	1040	1170
		Power (W)	29	38	48	58
	350	RPM	850	980	1100	1220
		Power (W)	40	50	62	73
	400	RPM	940	1060	1170	1280
		Power (W)	52	65	79	92
	450	RPM	1030	1140	1230	1330
		Power (W)	73	87	101	115
	500	RPM	1120	1220		
		Power (W)	97	111		

Blower performance data is based on the lowest nameplate voltage setting.
 Blower performance is based on a wet coil with clean 1-inch filter.
 Blower performance is based on operating conditions of 80°F DB and 67°F WB.
 CFM Tolerance is ±7%.
 RPM/Watt tolerance is ±10%.
 Cells in grey - option not available.

Models:
SM
006-036

Blower Performance SMS15

Blower Motor	Blower Motor Details		External Static Pressure (in. wg)			
	Speed Tap		0.0	0.1	0.2	0.3
(CT) EC	1	RPM	590			
		Power (W)	41			
		CFM	430			
	2	RPM	660	710	760	810
		Power (W)	49	59	59	59
		CFM	500	460	410	370
	3	RPM	760	800	840	890
		Power (W)	77	77	77	86
		CFM	600	570	520	480
	4	RPM	780	830	870	910
		Power (W)	92	92	103	103
		CFM	620	600	560	520
	5	RPM	870	900	940	990
		Power (W)	120	120	130	130
		CFM	710	690	660	630
(CV) EC	CFM		0.0	0.1	0.2	0.3
	500	RPM	660	740	820	900
		Power (W)	50	64	78	93
	600	RPM	760	830	890	970
		Power (W)	83	97	111	125
	650	RPM	810	870	930	1000
		Power (W)	104	118	133	147
	700	RPM	860	910	960	1030
		Power (W)	125	140	155	170

Blower performance data is based on the lowest nameplate voltage setting.
 Blower performance is based on a wet coil with clean 1-inch filter.
 Blower performance is based on operating conditions of 80°F DB and 67°F WB.
 CFM Tolerance is ±7%.
 RPM/Watt tolerance is ±10%.
 Cells in grey - option not available.

Blower Performance SMS18

Models:
SM
006-036

Blower Motor	Blower Motor Details		External Static Pressure (in. wg)			
	Speed Tap		0.0	0.1	0.2	0.3
(CT) EC	1	RPM	650			
		Power (W)	57			
		CFM	460			
	2	RPM	730	760	810	
		Power (W)	70	80	80	
		CFM	530	500	470	
	3	RPM	790	820	870	920
		Power (W)	97	97	107	107
		CFM	580	550	520	490
	4	RPM	880	920	950	1000
		Power (W)	137	137	147	147
		CFM	650	630	600	580
	5	RPM	950	990	1030	1070
		Power (W)	177	177	187	187
		CFM	710	690	670	650
(CV) EC	CFM		0.0	0.1	0.2	0.3
	600	RPM	660	740	820	900
		Power (W)	51	65	79	93
	650	RPM	690	770	845	920
		Power (W)	59	73	87	101
	700	RPM	720	800	870	940
		Power (W)	67	81	95	109
	750	RPM	755	825	890	960
		Power (W)	77	91	105	120
	800	RPM	790	850	910	980
		Power (W)	86	100	115	130

Blower performance data is based on the lowest nameplate voltage setting.
 Blower performance is based on a wet coil with clean 1-inch filter.
 Blower performance is based on operating conditions of 80°F DB and 67°F WB.
 CFM Tolerance is ±7%.
 RPM/Watt tolerance is ±10%.
 Cells in grey - option not available.

Models:
SM
006-036

Blower Performance SMS24

Blower Motor	Blower Motor Details		External Static Pressure (in. wg)			
			0.0	0.1	0.2	0.3
(CT) EC	Speed Tap		0.0	0.1	0.2	0.3
	1	RPM	640	690	730	
		Power (W)	62	68	76	
		CFM	710	660	600	
	2	RPM	690	730	780	850
		Power (W)	89	97	102	109
		CFM	820	770	720	670
	3	RPM	740	780	830	890
		Power (W)	120	129	134	143
		CFM	930	880	830	790
	4	RPM		830	880	920
		Power (W)		169	173	185
		CFM		990	950	910
	5	RPM				
		Power (W)				
CFM						
(CV) EC	CFM		0.0	0.1	0.2	0.3
	650	RPM	620	680	750	845
		Power (W)	83	101	119	138
	700	RPM	640	700	770	860
		Power (W)	96	115	134	153
	800	RPM	680	750	820	890
		Power (W)	122	143	164	184
	900	RPM	720	790	860	920
		Power (W)	155	176	197	218
	950	RPM	740	810	880	930
		Power (W)	193	214	234	255

Blower performance data is based on the lowest nameplate voltage setting.
 Blower performance is based on a wet coil with clean 1-inch filter.
 Blower performance is based on operating conditions of 80°F DB and 67°F WB.
 CFM Tolerance is ±7%.
 RPM/Watt tolerance is ±10%.
 Cells in grey - option not available.

Blower Performance SMS30

Models:
SM
006-036

Blower Motor	Blower Motor Details	External Static Pressure (in. wg)				
		0.0	0.1	0.2	0.3	
(CT) EC	Speed Tap	0.0	0.1	0.2	0.3	
	1	RPM	770	770	800	
		Power (W)	105	113	118	
		CFM	880	830	780	
	2	RPM	860	840	880	940
		Power (W)	151	158	165	170
		CFM	1000	960	920	900
	3	RPM	950	920	960	1000
		Power (W)	210	217	225	229
		CFM	1140	1100	1070	1030
	4	RPM		1000	1040	1060
		Power (W)		285	295	299
		CFM		1230	1200	1160
	5	RPM				
		Power (W)				
CFM						
(CV) EC	CFM	0.0	0.1	0.2	0.3	
	850	RPM	754	776	846	920
		Power (W)	147	173	199	224
	900	RPM	789	807	874	943
		Power (W)	171	198	224	250
	1000	RPM	860	870	930	990
		Power (W)	219	247	275	303
	1100	RPM	920	920	980	1030
		Power (W)	310	336	361	387

Blower performance data is based on the lowest nameplate voltage setting.
 Blower performance is based on a wet coil with clean 1-inch filter.
 Blower performance is based on operating conditions of 80°F DB and 67°F WB.
 CFM Tolerance is ±7%.
 RPM/Watt tolerance is ±10%.
 Cells in grey - option not available.

Models:
SM
006-036

Blower Performance SMS36

Blower Motor	Blower Motor Details		External Static Pressure (in. wg)			
			0.0	0.1	0.2	0.3
(CT) EC	Speed Tap		0.0	0.1	0.2	0.3
	1	RPM	880	910	950	
		Power (W)	131	132	141	
		CFM	990	950	910	
	2	RPM	970	1010	1050	1090
		Power (W)	191	193	199	209
		CFM	1130	1100	1080	1040
	3	RPM	1070	1110	1150	1170
		Power (W)	267	269	276	288
		CFM	1280	1260	1240	1190
	4	RPM	1190	1210	1250	1270
		Power (W)	373	376	387	398
		CFM	1450	1420	1410	1370
	5	RPM				
		Power (W)				
CFM						
(CV) EC	CFM		0.0	0.1	0.2	0.3
	900	RPM	820	880	940	1010
		Power (W)	183	208	234	260
	1000	RPM	887	947	1000	1070
		Power (W)	242	270	297	325
	1200	RPM	1020	1070	1120	1180
		Power (W)	362	393	425	456
	1250	RPM	1053	1103	1153	1207
			411	440	470	499

Blower performance data is based on the lowest nameplate voltage setting.
 Blower performance is based on a wet coil with clean 1-inch filter.
 Blower performance is based on operating conditions of 80°F DB and 67°F WB.
 CFM Tolerance is ±7%.
 RPM/Watt tolerance is ±10%.
 Cells in grey - option not available.

Blower Performance SMT06

Models:
SM
006-036

Blower Motor	Blower Motor Details		External Static Pressure (in. wg)							
			0.1	0.2	0.3	0.4	0.5	0.6	0.7	0.8
(CV) EC	CFM									
	150	RPM	486	570	660	738	822	894	936	984
	200	RPM	648	760	880	984	1096	1192	1248	1312
	250	RPM	810	950	1100	1230	1370	1490	1560	1640
	300	RPM	900	1050	1180	1300	1410	1520	1590	1660
	350	RPM	1000	1140	1260	1380	1450	1540	1620	1690
	400	RPM	1100	1230	1340	1450	1490	1570		

Blower performance data is based on the lowest nameplate voltage setting.
 Blower performance is based on a wet coil with clean 1-inch filter.
 Blower performance is based on operating conditions of 80°F DB and 67°F WB.
 CFM Tolerance is ±7%.
 RPM/Watt tolerance is ±10%.
 Cells in grey - option not available.

Models:
SM
006-036

Blower Performance

SMT09

Blower Motor	Blower Motor Details		External Static Pressure (in. wg)												
			0.1	0.2	0.3	0.4	0.5	0.6	0.7	0.8					
(CT) EC	Speed Tap		0.1	0.2	0.3	0.4	0.5	0.6	0.7	0.8					
	1	RPM	980	1080	1170	1260	1360								
		Power (W)	47	51	54	58	62								
		CFM	340	320	290	270	240								
	2	RPM	1060	1160	1230	1320	1390				1500				
		Power (W)	58	62	66	70	75				79				
		CFM	380	360	330	310	280				260				
	3	RPM				1230	1310				1390	1440	1530	1590	1650
		Power (W)				79	84				88	92	97	101	105
		CFM				400	380				360	340	320	290	270
	4	RPM				1470	1480				1550	1630	1680		
		Power (W)				108	113				117	122	126		
CFM		410				390	370				360	340			
(CV) EC	CFM		0.1	0.2	0.3	0.4	0.5	0.6	0.7	0.8					
	250	RPM	810	950	1100	1230	1370	1490	1560	1640					
		Power (W)	30	38	47	57	67	78	89	101					
	300	RPM	900	1050	1180	1300	1410	1520	1590	1660					
		Power (W)	38	48	58	69	81	93	105	118					
	350	RPM	1000	1140	1260	1380	1450	1540	1620	1690					
		Power (W)	50	62	73	85	98	110	124	137					
	400	RPM	1100	1230	1340	1450	1490	1570							
		Power (W)	65	79	92	105	119	132							

Blower performance data is based on the lowest nameplate voltage setting.
 Blower performance is based on a wet coil with clean 1-inch filter.
 Blower performance is based on operating conditions of 80°F DB and 67°F WB.
 CFM Tolerance is ±7%.
 RPM/Watt tolerance is ±10%.
 Cells in grey - option not available.

Blower Performance SMT12

Models:
SM
006-036

Blower Motor	Blower Motor Details	External Static Pressure (in. wg)								
		0.1	0.2	0.3	0.4	0.5	0.6	0.7	0.8	
(CT) EC	Speed Tap	0.1	0.2	0.3	0.4	0.5	0.6	0.7	0.8	
	1	RPM	1070	1140	1230	1320	1400			
		Power (W)	66	70	74	78	82			
		CFM	410	380	360	330	310			
	2	RPM	1140	1190	1280	1370	1430	1510	1580	
		Power (W)	54	58	61	65	69	73	77	
		CFM	450	420	400	380	360	330	310	
	3	RPM	1190	1240	1320	1400	1450	1530	1590	1660
		Power (W)	79	83	87	91	96	100	104	108
		CFM	480	460	440	420	400	370	350	330
	4	RPM					1510	1580	1630	1690
		Power (W)					132	137	141	145
CFM		500					480	460	440	
(CV) EC	CFM	0.1	0.2	0.3	0.4	0.5	0.6	0.7	0.8	
	300	RPM	890	1040	1170	1300	1400	1500	1570	1660
		Power (W)	38	48	58	69	81	93	105	118
	350	RPM	980	1100	1220	1340	1430	1520	1590	1670
		Power (W)	50	62	73	85	98	110	124	137
	400	RPM	1060	1170	1280	1380	1450	1540		
		Power (W)	65	79	92	105	119	132		
	450	RPM	1140	1230	1330	1430				
		Power (W)	87	101	115	128				
	500	RPM	1220							
		Power (W)	111							

Blower performance data is based on the lowest nameplate voltage setting.
 Blower performance is based on a wet coil with clean 1-inch filter.
 Blower performance is based on operating conditions of 80°F DB and 67°F WB.
 CFM Tolerance is ±7%.
 RPM/Watt tolerance is ±10%.
 Cells in grey - option not available.

Models:
SM
006-036

Blower Performance SMT15

Blower Motor	Blower Motor Details		External Static Pressure (in. wg)																	
			0.1	0.2	0.3	0.4	0.5	0.6	0.7	0.8										
(CT) EC	Speed Tap		0.1	0.2	0.3	0.4	0.5	0.6	0.7	0.8										
	1	RPM	720	770	810	870														
		Power (W)	66	70	74	79														
		CFM	560	520	480	430														
	2	RPM	770	810	850	910					960									
		Power (W)	79	83	87	92					98									
		CFM	610	570	540	500					450									
	3	RPM	820	860	890	930					990				1040					
		Power (W)	95	101	104	110					114				121					
		CFM	660	630	600	540					500				460					
	4	RPM	850	900	910	970					1010				1070			1120		
		Power (W)	107	111	117	123					128				134			141		
		CFM	690	670	630	600					560				520			470		
	5	RPM			960	1010					1050				1100			1150		1210
		Power (W)			142	147					153				159			166		167
CFM		710			670	640					600				560			510		
(CV) EC	CFM		0.1	0.2	0.3	0.4	0.5	0.6	0.7	0.8										
	500	RPM	670	750	830	910	990	1060	1130	1210										
		Power (W)	50	64	78	93	107	121	135	150										
	550	RPM	715	795	860	940	1010	1080	1145	1220										
		Power (W)	67	81	95	109	123	137	151	166										
	600	RPM	760	840	890	970	1030	1100	1160	1230										
		Power (W)	83	97	111	125	139	153	167	181										
	650	RPM	810	880	920	1000	1050	1120	1180	1250										
		Power (W)	104	118	133	147	162	176	191	205										
	700	RPM	860	930	960	1030	1070	1140	1200	1260										
		Power (W)	125	140	155	170	185	199	214	229										

Blower performance data is based on the lowest nameplate voltage setting.
 Blower performance is based on a wet coil with clean 1-inch filter.
 Blower performance is based on operating conditions of 80°F DB and 67°F WB.
 CFM Tolerance is ±7%.
 RPM/Watt tolerance is ±10%.
 Cells in grey - option not available.

Blower Performance SMT18

Models:
SM
006-036

Blower Motor	Blower Motor Details	External Static Pressure (in. wg)									
		0.1	0.2	0.3	0.4	0.5	0.6	0.7	0.8		
(CT) EC	Speed Tap	0.1	0.2	0.3	0.4	0.5	0.6	0.7	0.8		
	1	RPM	750	800	850	880					
		Power (W)	73	77	82	87					
		CFM	590	550	500	450					
	2	RPM	820	860	910	960	990	1030			
		Power (W)	95	99	105	110	115	119			
		CFM	660	630	590	540	500	460			
	3	RPM	890	930	960	1040	1060	1090	1130	1200	
		Power (W)	123	127	132	138	144	149	154	158	
		CFM	730	700	670	640	590	550	520	490	
	4	RPM			970	1000	1080	1110	1140	1170	1220
		Power (W)			148	152	158	164	170	176	172
		CFM			750	720	690	660	610	570	520
	5	RPM						1230	1180	1180	
		Power (W)						217	182	154	
CFM		730						580	470		
(CV) EC	CFM	0.1	0.2	0.3	0.4	0.5	0.6	0.7	0.8		
	600	RPM	760	840	920	1010	1070	1130	1200	1270	
		Power (W)	88	102	116	130	144	158	172	186	
	650	RPM	810	885	950	1050	1110	1170	1240	1305	
		Power (W)	113	128	142	156	170	185	199	213	
	700	RPM	860	930	980	1090	1150	1210	1280	1340	
		Power (W)	138	153	167	182	196	211	225	240	
	750	RPM	910	970	1015	1130	1185	1245	1320	1370	
		Power (W)	169	185	200	216	231	247	262	278	
	800	RPM	960	1010	1050	1170	1220	1280	1360	1400	
		Power (W)	199	216	232	249	265	282	298	315	

Blower performance data is based on the lowest nameplate voltage setting.
 Blower performance is based on a wet coil with clean 1-inch filter.
 Blower performance is based on operating conditions of 80°F DB and 67°F WB.
 CFM Tolerance is ±7%.
 RPM/Watt tolerance is ±10%.
 Cells in grey - option not available.

Models:
SM
006-036

Blower Performance SMT24

Blower Motor	Blower Motor Details		External Static Pressure (in. wg)								
			0.1	0.2	0.3	0.4	0.5	0.6	0.7	0.8	
(CT) EC	Speed Tap		0.1	0.2	0.3	0.4	0.5	0.6	0.7	0.8	
	1	RPM	680	720	770	820	870	930			
		Power (W)	110	117	123	131	138	146			
		CFM	840	800	760	720	670	630			
	2	RPM	730	770	810	860	910	960	1020	1080	
		Power (W)	145	153	160	167	175	183	192	199	
		CFM	940	900	860	830	790	750	710	670	
	3	RPM					900	950	1000	1050	1100
		Power (W)					212	219	227	236	246
		CFM					940	900	870	830	790
	4	RPM							1080	1120	
		Power (W)							285	294	
		CFM							940	900	
	5	RPM									
		Power (W)									
CFM											
(CV) EC	CFM		0.1	0.2	0.3	0.4	0.5	0.6	0.7	0.8	
	650	RPM	585	655	730	800	860	935	1005	1075	
		Power (W)	65	83	101	119	138	156	174	192	
	750	RPM	635	700	770	835	895	965	1030	1090	
		Power (W)	90	109	129	149	169	189	209	228	
	850	RPM	685	745	810	870	930	995	1055	1110	
		Power (W)	118	139	160	181	201	222	244	264	
	950	RPM	740	790	850	900	970	1020	1080	1120	
		Power (W)	172	193	214	234	255	276	296	317	

Blower performance data is based on the lowest nameplate voltage setting.
 Blower performance is based on a wet coil with clean 1-inch filter.
 Blower performance is based on operating conditions of 80°F DB and 67°F WB.
 CFM Tolerance is ±7%.
 RPM/Watt tolerance is ±10%.
 Cells in grey - option not available.

Blower Performance SMT30

Models:
SM
006-036

Blower Motor	Blower Motor Details	External Static Pressure (in. wg)									
		0.1	0.2	0.3	0.4	0.5	0.6	0.7	0.8		
(CT) EC	Speed Tap	0.1	0.2	0.3	0.4	0.5	0.6	0.7	0.8		
	1	RPM	810	840	870	910	950	1000	1050	1090	
		Power (W)	177	185	194	203	212	221	229	236	
		CFM	1040	1000	960	920	880	850	810	770	
	2	RPM	850	890	920	960	990	1040	1090	1130	
		Power (W)	220	229	237	247	257	266	275	283	
		CFM	1110	1080	1050	1010	970	940	910	880	
	3	RPM					1070	1110	1150	1180	
		Power (W)					351	363	373	384	
		CFM					1140	1100	1070	1040	
	4	RPM								1190	1220
		Power (W)								442	451
		CFM								1170	1140
	5	RPM									
		Power (W)									
CFM											
(CV) EC	CFM	0.1	0.2	0.3	0.4	0.5	0.6	0.7	0.8		
	850	RPM	684	746	806	866	938	1000	1062	1120	
		Power (W)	122	147	173	199	224	250	276	301	
	950	RPM	748	808	862	922	986	1046	1100	1154	
		Power (W)	167	194	221	249	276	303	330	357	
	1050	RPM	813	870	920	980	1033	1090	1140	1187	
		Power (W)	222	249	277	304	331	358	385	413	
	1100	RPM	847	900	950	1010	1057	1110	1160	1204	
		Power (W)	253	280	307	333	359	386	412	439	

Blower performance data is based on the lowest nameplate voltage setting.
 Blower performance is based on a wet coil with clean 1-inch filter.
 Blower performance is based on operating conditions of 80°F DB and 67°F WB.
 CFM Tolerance is ±7%.
 RPM/Watt tolerance is ±10%.
 Cells in grey - option not available.

Models:
SM
006-036

Blower Performance SMT36

Blower Motor	Blower Motor Details	External Static Pressure (in. wg)								
		0.1	0.2	0.3	0.4	0.5	0.6	0.7	0.8	
(CT) EC	Speed Tap	0.1	0.2	0.3	0.4	0.5	0.6	0.7	0.8	
	1	RPM	830	860	890	930	970	1020		
		Power (W)	193	201	211	221	231	239		
		CFM	1080	1050	1020	980	950	910		
	2	RPM	920	950	970	1010	1060	1090	1140	1170
		Power (W)	265	273	282	294	305	316	326	335
		CFM	1220	1190	1150	1130	1100	1060	1030	1000
	3	RPM	1020	1040	1070	1110	1140	1180	1220	1250
		Power (W)	361	369	377	387	401	414	426	428
		CFM	1370	1340	1310	1290	1260	1230	1200	1160
	4	RPM	940	970	1010	1050	1070	1150		
		Power (W)	315	322	332	341	351	430		
		CFM	1240	1230	1200	1170	1140	1200		
	5	RPM								
		Power (W)								
CFM										
(CV) EC	CFM	0.1	0.2	0.3	0.4	0.5	0.6	0.7	0.8	
	900	RPM	710	760	820	880	950	1020	1070	1130
		Power (W)	132	157	183	208	234	260	285	311
	1050	RPM	810	860	910	970	1030	1090	1150	1200
		Power (W)	215	244	272	301	329	358	386	415
	1200	RPM	910	950	1000	1050	1110	1160	1220	1260
		Power (W)	299	331	362	393	425	456	487	519
	1350	RPM	1000	1050	1090	1140	1190	1240	1290	1330
		Power (W)	458	483	509	534	560	585	611	636

Blower performance data is based on the lowest nameplate voltage setting.
 Blower performance is based on a wet coil with clean 1-inch filter.
 Blower performance is based on operating conditions of 80°F DB and 67°F WB.
 CFM Tolerance is ±7%.
 RPM/Watt tolerance is ±10%.
 Cells in grey - option not available.

Chassis Pre-Installation

See Figures 18-21

1. Check chassis data plate. Verify chassis is correct for the cabinet. Chassis I.D. sticker should match sticker on cabinet-blower housing.
 2. Remove compressor cover, check for any shipping or handling damage. Make repairs or adjustments.
 - a. Verify refrigerant tubing is free of kinks or dents, and that it does not touch other tubes or unit parts as it passes over or through. Adjust if needed and separate with closed-cell insulation.
 - b. Inspect insulation inside compressor enclosure for rubs from tubing or reversing valve. Adjust tubing or RV inward if needed. Be careful not to cause contact somewhere else.
 3. Inspect all electrical connections. Connections must be clean and tight at the terminals.
 4. Replace any panels or covers removed for steps 2-4.
- The chassis is now ready for installation. Always keep chassis upright.

Figure 17: Front

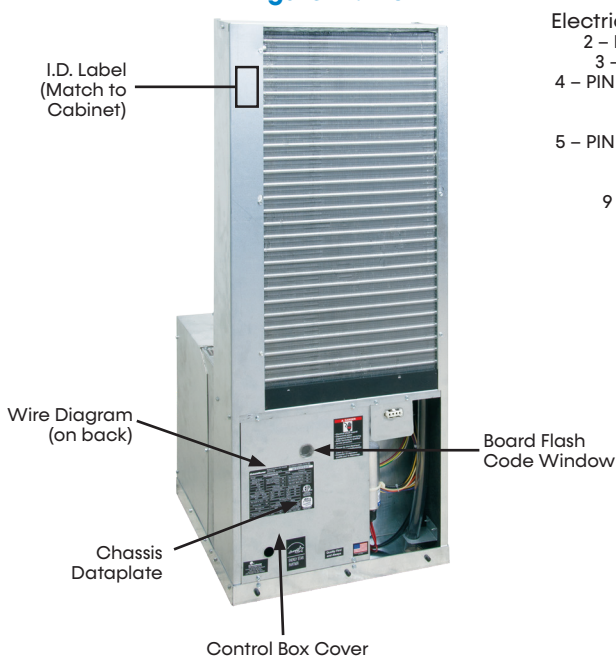

Figure 18: Front

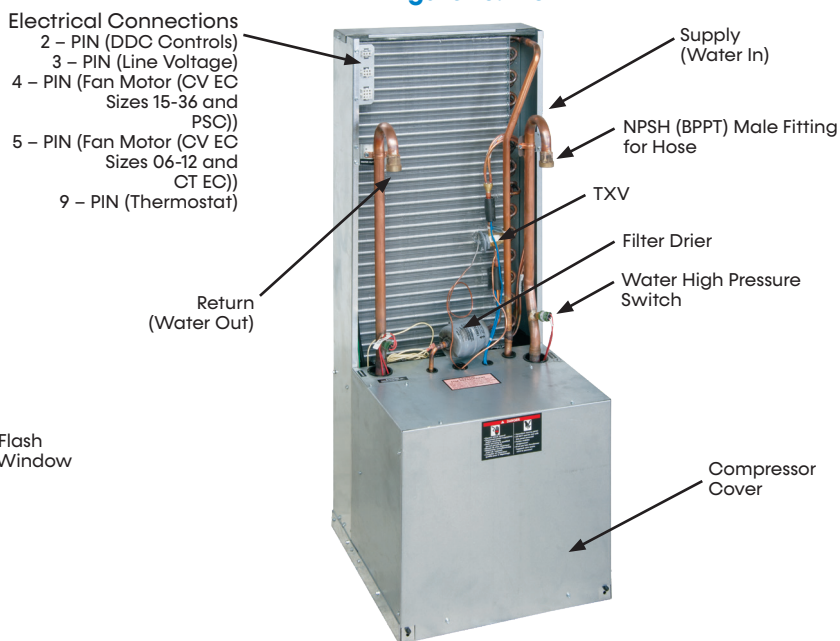

Figure 19: Control Box Cover Removed

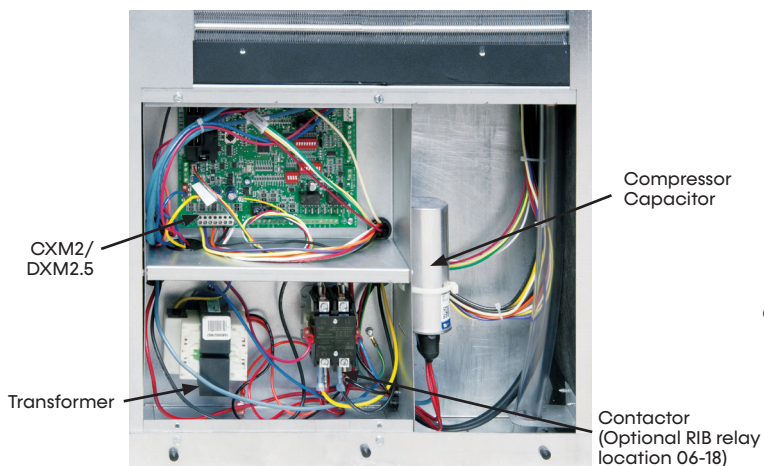
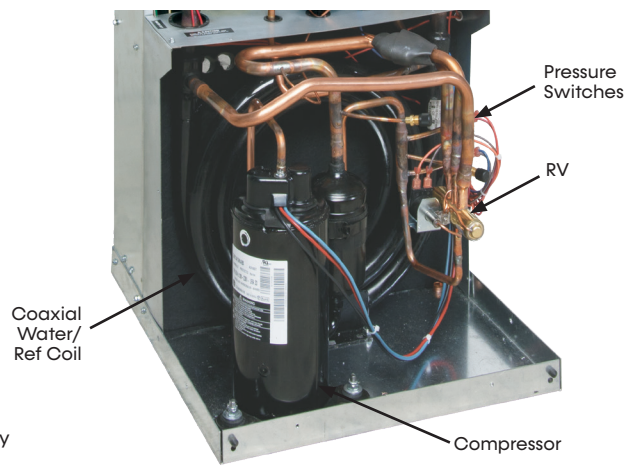

Figure 20: Enclosure Removed



Models:
SM
006-036

Hose Kit and Chassis Installation

HOSE KIT AND CHASSIS INSTALLATION

After cabinets are installed, and walls finished remove the filter and front blockoff panel. **SAVE THESE FOR RE-INSTALLATION AFTER THE CHASSIS IS INSTALLED!**

Step 1: Remove filter and inner panel (Figure 21). For chassis shipped in cabinet, remove and discard four shipping bolts.

Figure 21: Front

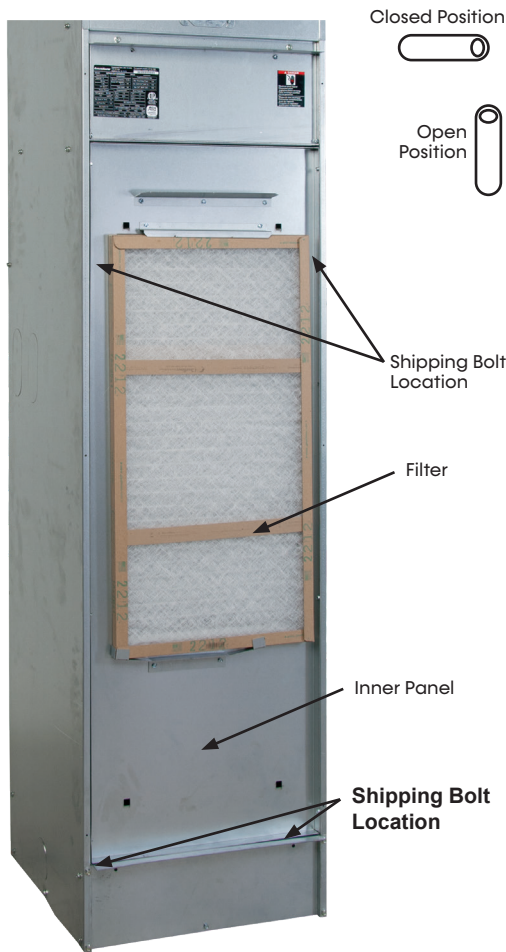

Step 2: Attach the Flex Hoses to shutoffs in the cabinet. Unpack and examine hose kit. Remove all shipping and/or packing material such as rubber bands, plastic caps, and styrofoam. Hose kit should contain (2) hoses.

CAUTION
If the risers are under pressure, do not open shut off valves until installation is complete!

Figure 22: Return and Supply Shutoff Location (Cabinet Style 2 Riser Back Left)

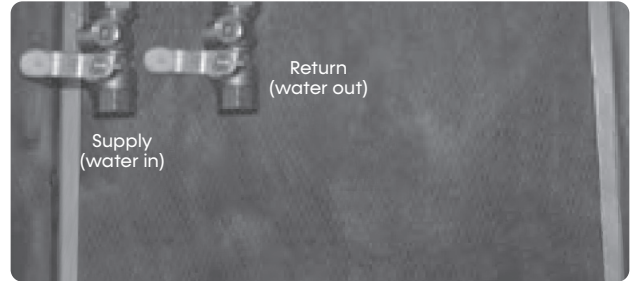

WARNING
Do Not Remove valve or loosen valve-union nut without first draining the risers below cabinet level. Check with contractor if risers have water.

WARNING
Under no circumstances should any part of the hose itself be gripped or twisted by hand, pliers, channel locks or any other tool. Leakage or bursting may occur! Wrenches are used on pipe threads only. Hand tighten swivel connections.

AHU HOSE

Locate the two shutoff valves inside the unit cabinet (Figure 24). Supply (water in) is always closest to corner). Check to see if swivel ends have washer inside them (Figure 25 on page 72). Attach the hoses to the water valves.

NOTE: Make sure the valve handles are in a position that enables them to be fully opened and closed.

Figure 23: AHU Hoses

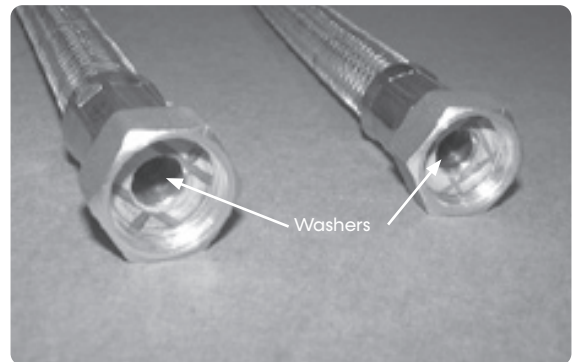

Table 6: Metal Hose Minimum Bend Radii

Hose Diameter	Minimum Bend Radii
1/2" [12.7 mm]	2-1/2" [6.4 cm]
3/4" [19.1 mm]	4" [10.2 cm]
1" [25.4 mm]	5-1/2" [14 cm]
1-1/4" [31.8 mm]	6-3/4" [17.1 cm]

Hose Kit and Chassis Installation

Step 3: Attach AHU hoses to the Chassis. Check the swivel ends of the hoses (Figure 25). Washers must be in the hose for water tight connection. Slide the chassis part way into the cabinet. Match the WATER IN (supply) hose to the WATER IN tube on the chassis and the WATER OUT (Return) hose to the WATER OUT tube. Position hose toward chassis, use gentle loop-see bend radii Table 6 on page 70. Hand-tighten the hose.

Do not bend hoses at less than the minimum bend radius for the hose selected. Less than the minimum bend radius may cause the hose to collapse, which reduces water flow rate. Install an angle adapter to avoid sharp bends in the hose when the radius falls below the required minimum.

CAUTION

Do not bend or kink supply lines or hoses.

CAUTION

Piping must comply with all applicable codes.

CAUTION

Corrosive system water requires corrosion resistant fittings and hoses, and may require water treatment.

WARNING

Under no circumstances should any part of the hose itself be gripped or twisted by hand, pliers, channel locks or any other tool. Leakage or bursting may occur! Always use a back-up wrench when tightening the hose.

Step 4: Chassis Installation - Check condensate pan is free and on 4 rubber grommets.

Install the Chassis as follows:

1. Slide chassis fully into cabinet. Check hose for kinks, do not allow less than minimum bend radius (see Table 6 on page 70), pull chassis partway out, loosen hose and reposition hose if needed, re-tighten.
2. Verify that both the shut-off valves are closed. See Figure 24. (handle horizontal)
3. Verify riser stack has been pressure tested, and all leaks have been repaired.
4. Flush system following the procedure in Preparation for Startup Section of this manual.

WARNING

Do Not open valves to chassis until system has flushed and purged of air!

NOTICE

After the system has been filled and system pump is started, all connections should be rechecked for water leaks. ClimateMaster WILL NOT be responsible or liable for damage caused by water leaks at any field water connections!

5. When the system is clean and flushed, open both water shut off valves and check piping for leaks. Repair all leaks before continuing.
6. Complete electrical connections between cabinet and chassis. Connect wire harnesses hanging down from under side of control box to chassis connections. (See Figure 26). Check that Molex connectors are snapped together, pull gently on connector - do not pull on wires.

Models:
SM
006-036

Hose Kit and Chassis Installation

Figure 24: Chassis Connections



7. Before installing the inner panel and filter, perform the following checks:
 - a. Verify all pre-installation and installation steps were completed.
 - b. Verify all copper tubes do not touch or rub other tubes or parts of the unit.
 - c. Ensure that fan wheel rotates freely and does not rub against housing. If rough handling during shipping has caused fan wheel to shift, adjust as necessary.
 - d. Verify that water-piping connections to the chassis are complete and that unit service valves which were closed during flushing have been opened.
 - e. Verify that power between the cabinet and chassis is properly connected.
 - f. Ensure that the unit drain is properly positioned, secured, and not blocked.
 - g. Verify that the nuts used to secure the blower assembly to the fan deck are tight.
 - h. Check that chassis is fully inserted, front to back, side gap equal and chassis is centered in cabinet.
 - i. After the system is filled and system pump is started, all connections should be re-checked for water leaks. ClimateMaster WILL NOT be responsible or liable for damage caused by water leaks at any field water connections!

8. Re-attach the inner panel (8 screws) and filter as shown in the figure below. The chassis must free-float on condensate pan. If inner-panel holes do not align, push chassis further in.
9. Install the cabinet return-air panel after startup. See installation instructions shipped with return-air/access panel for detailed information.

Figure 25: Front Panel

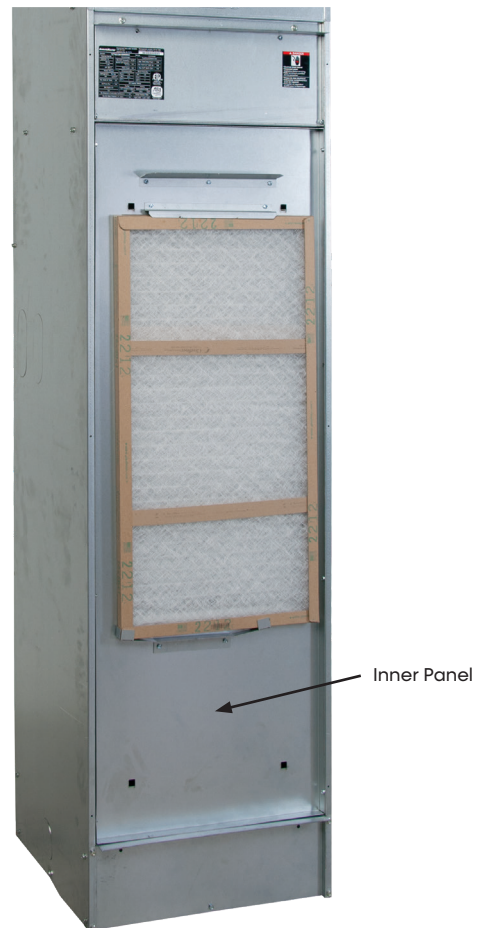

Startup Preparation

WARNING

To prevent injury or death due to electrical shock or contact with moving parts, open unit disconnect before servicing unit.

SYSTEM CLEANING AND FLUSHING

Cleaning and flushing the unit is the single most important step to ensure proper startup and continued efficient operation of the system. Follow the instructions below to properly clean and flush the system: Do not flush through SM chassis. Coax can get plugged and water flow will be reduced, causing poor performance and may cause LT1 sensor to trip.

1. Verify that electrical power to the unit is disconnected.
2. Verify that supply and return riser service valves are closed at each unit.
3. Fill the system with water. Bleed all air from the system but do not allow the system to over flow. Check the system for leaks and make any required repairs.
4. Adjust the water and air level in the expansion tank.
5. With strainers in place, start the pumps (ClimateMaster recommends a strainer with a #20 stainless-steel wire mesh). Systematically check that all of the air is bled from the system.
6. Verify that make-up water is available and adjusted to properly replace any space remaining when all air is evacuated. Check the system for leaks and make any additional repairs required.
7. Set the boiler to raise the loop temperature to approximately 85°F (29.4°C). Open the drain at the lowest point in the system. Verify that make-up water replacement rate equals rate of bleed. Continue to bleed the system until the water appears clean or for at least three hours whichever is longer.
8. Completely drain the system.

CAUTION

Do not use "Stop-Leak" or any similar chemical agent in this system. Addition of these chemicals to the loop water can foul the system and can inhibit unit operation.

CAUTION

To avoid possible damage to piping systems constructed of plastic piping, DO NOT allow loop temperature to exceed 110°F (43.3°C).

Flush risers as follows (Refer to Figure 26 on page 74):

1. Remove cabinet filter and front inner panel. Save these for re-installation after the chassis is installed.
2. Close shut-off valves at each cabinet on the riser except the shut-off valve on the top floor.
3. At the top floor, install the hose kit and connect the ends of the hoses with the factory riser flush adapter from AFL5751. For sweat shutoffs, one AHU hose can be used.
4. Flush solution through supply riser. NOTE: The solution passes through the top floor connection down the return riser.
5. When the building has more than 10 floors, connect the supply and return runouts on the top two floors to divide the water flow and reduce pressure drop at the pump.
6. Repeat flushing procedure for each set of risers in the building.
7. Refill the system and add in a proportion of trisodium phosphate approximately one pound per 150 gallons [0.4 kg per 500 liters] of water. Reset the boiler to raise the loop temperature to about 100°F (37.8°C).
8. Circulate the solution for between 8 to 24 hours. At the end of this period, shut off the circulating pump and drain the solution. Repeat system cleaning if desired.
9. Open the supply and return riser service valves at each unit. Refill the system and bleed off all air.
10. Units with internal pumps, to prevent cavitation and pump failure, air must be bled from both sides of pump. First close off supply and open return shutoff. Open air bleed downstream of pump, bleed air, next close return and open supply shutoff, bleed air. Close air bleed.
11. Test the system pH with litmus paper. The system water should have a pH of 6 to 8.5. Add chemicals as appropriate to maintain pH levels.
12. When the system is successfully cleaned, flushed, refilled, and bled, check the main system panels, safety cutouts, and alarms. Set controls to properly maintain loop temperature.

Models:
SM
006-036

Startup Preparation

Figure 26: Typical Piping Arrangement for Flushing Risers

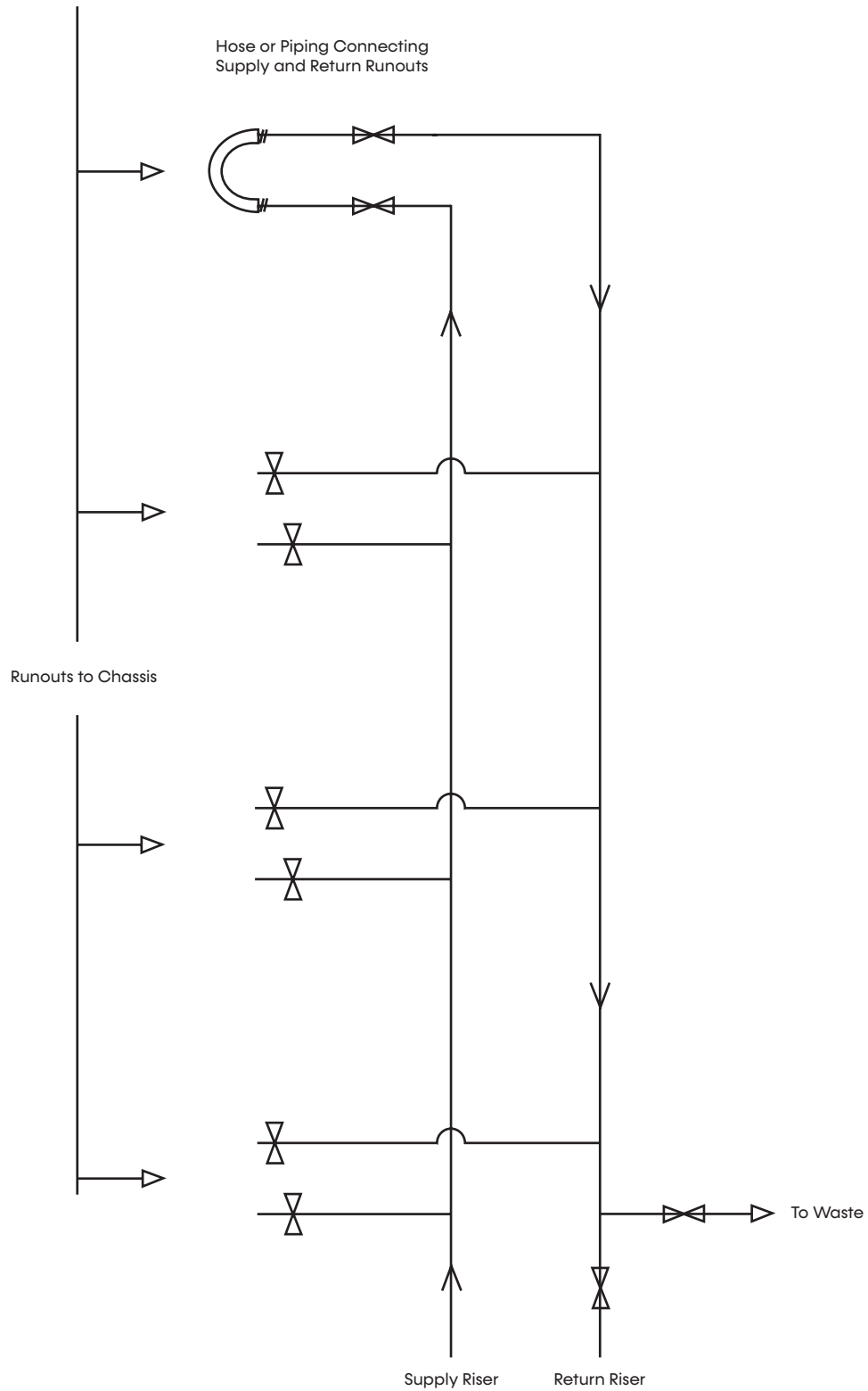

Controls: CXM2 and DXM2.5



CXM2 Controls

For detailed controller information, see the CXM2 Application, Operation, and Maintenance (AOM) manual (part # 97B0137N01). To confirm the controller type of your particular unit, refer to digit 9 on the unit model number and the unit nomenclature diagram found on page 3 of this manual.



DXM2.5 Controls

For detailed controller information, see the DXM2.5 Application, Operation, and Maintenance (AOM) manual (part # 97B0142N01). To confirm the controller type of your particular unit, refer to digit 9 on the unit model number and the unit nomenclature diagram found on page 3 of this manual.

Models:
SM
006-036

Operating Limits and Commissioning Conditions

OPERATING LIMITS

Environment – Units are designed for indoor installation only. Never install units in areas subject to freezing or where humidity levels could cause cabinet condensation (such as unconditioned spaces subject to 100% outside air).

Power Supply – Voltage utilization shall comply with AHRI Standard 110 or values provided in the electrical data tables.

Operation and performance is primarily dependent upon return air temperature, airflow, water temperature, water flow rate and ambient air temperature. This water to air heat pump is capable of operating over a wide temperature range and with flow rates of between 1.5 GPM (.1 l/s) and 3 GPM (.19 l/s) per ton, however usually no more than one of these factors may be at a minimum or maximum level at a time.

COMMISSIONING CONDITIONS

Starting conditions vary depending upon model and are based upon the following notes:

NOTES:

1. Commissioning conditions are not normal or continuous operating conditions. Minimum/maximum limits are startup conditions to bring the building space up to occupancy temperatures. Units are not designed to operate under these conditions on a regular basis.
2. Voltage utilization range complies with AHRI Standard 110.

 **NOTICE**

NOTE: The manufacturer strongly recommends all piping connections, both internal and external to the unit, be pressure tested by an appropriate method prior to any finishing of the interior space or before access to all connections is limited. Test pressure may not exceed the maximum allowable pressure for the unit and all components within the water system. The manufacturer will not be responsible or liable for damages from water leaks due to inadequate or lack of a pressurized leak test, or damages caused by exceeding the maximum pressure rating during installation.

Operating Limits and Commissioning Conditions

Table 7: Operating Limits

Operating Limits	Cooling	Heating
Air Limits		
Min. ambient air, DB	*10°F [-12°C]	*10°F [-12°C]
Max. ambient air, DB	130°F [54.4°C]	130°F [54.4°C]
Min. entering air, DB/WB	65/45°F [18/7°C]	50°F [10°C]
Max. entering air, DB/WB	90/72°F [32/22°C]	80°F [27°C]
Min/Max Airflow (CFM/Ton)	**300 to 500 CFM/Ton	
Water Limits		
Min. entering water	***30°F [-1°C]	20°F [-6.7°C]
Max. entering water	120°F [49°C]	90°F [32°C]
Water Flow Range	1.5 to 3.0 GPM/ton [1.6 to 3.2 l/m per kW]****	

- Notes:
- *To prevent unit damage, the water loop should contain antifreeze to prevent freezing when not in operation.
 - ** Refer to specific blower tables for each model size
 - ***With unit flow-control automation.
 - **** Unless specified different on performance table for any model size

Table 8: Commissioning Conditions

Commissioning Conditions	Cooling	Heating
Air Limits		
Min. ambient air, DB	*10°F [-12°C]	*10°F [-12°C]
Max. ambient air, DB	130°F [54.4°C]	130°F [54.4°C]
Min. entering air, DB/WB	65/45°F [18/7°C]	² 40°F [4.4°C]
Max. entering air, DB/WB	¹ 100/75°F [38/24°C]	80°F [27°C]
Min/Max Airflow (CFM/Ton)	**300 to 500 CFM/Ton	
Water Limits		
Min. entering water	***20°F [-6.7°C]	20°F [-6.7°C]
Max. entering water	120°F [49°C]	90°F [32°C]
Water Flow Range	1.5 to 3.0 GPM/ton [1.6 to 3.2 l/m per kW]****	

- Notes:
- *To prevent unit damage, the water loop should contain antifreeze to prevent freezing when not in operation.
 - ** Refer to specific blower tables for each model size
 - ***With unit flow-control automation.
 - **** Unless specified different on performance table for any model size
 - ¹Commission units for cooling at entering air temperatures of 100/75°F [38/24°C] only at rated water flow or 3 GPM/ton.
 - ²Commission units for heating at entering air temperature of 40°F [4.4°C] only at rated water flow or 3 GPM/ton.

SMS Max Working Pressures

Options	Max Pressure PSIG [kPa]
Base Unit	400 [2,757]
Internal Secondary Pump (ISP)	200 [1,378]
Internal Motorized Water Valve (MWV)	300 [2,068]
Internal Modulating Valve	300 [2,068]
Variable Speed Pump	145 [999]

SMT Max Working Pressures

Options	Max Pressure PSIG [kPa]
Base Unit	400 [2,757]
Internal Secondary Pump (ISP)	200 [1,378]
Internal Motorized Water Valve (MWV)	300 [2,068]
Internal Modulating Valve	300 [2,068]
Internal Auto Flow Valve	400 [2,757]
Variable Speed Pump	145 [999]

Models:
SM
006-036

Unit and System Checkout

SYSTEM CHECKOUT

BEFORE POWERING SYSTEM, please check the following:

- System-water temperature:** Check water temperature for proper range and also verify heating and cooling set points for proper operation.
- System pH:** Check and adjust water pH if necessary to maintain a level between 6 and 8.5. Proper pH promotes longevity of hoses and fittings (see Table 4 on page 39).
- System flushing:** Verify that all hoses are connected end to end when flushing to ensure that debris bypasses the unit heat exchanger, water valves and other components. Water used in the system must be potable quality initially and clean of dirt, piping slag, and strong chemical cleaning agents. Verify that all air is purged from the system. Air in the system can cause poor operation or system corrosion.
- Cooling tower/boiler:** Check equipment for proper set points and operation.
- Standby pumps:** Verify that the standby pump is properly installed and in operating condition.
- System controls:** Verify that system controls function and operate in the proper sequence.
- Low-water temperature cutout:** Verify that low water temperature cut-out controls are provided for the outdoor portion of the loop. Otherwise, operating problems may occur.
- System control center:** Verify that the control center and alarm panel have appropriate set points and are operating as designed.
- Miscellaneous:** Note any questionable aspects of the installation.

UNIT CHECKOUT

- Balancing/shutoff valves:** Ensure that all isolation valves are open and water control valves are wired.
- Line voltage and wiring:** Verify that voltage is within an acceptable range for the unit and wiring and fuses/breakers are properly sized. Verify that low voltage wiring is complete.
- Unit control transformer:** Ensure that transformer has the properly selected voltage tap. Commercial 208/230V units are factory wired for 208V.
- Entering water and air:** Ensure that entering water and air temperatures are within operating limits of Tables 7 and 8.
- Low water temperature cutout:** Verify that low water temperature cut-out on the CXM2/DXM2.5 control is properly set.
- Unit fan:** Manually rotate fan to verify free rotation and ensure that blower wheel is secured to the motor shaft. Be sure to remove any shipping supports if needed. DO NOT oil motors upon startup. Fan motors are pre-oiled at the factory. Check unit fan speed selection and compare to design requirements.
- Condensate line:** Verify that condensate line is open and properly pitched toward drain.
- Water flow balancing:** Record inlet and outlet water temperatures for each heat pump upon startup. This check can eliminate nuisance trip outs and high velocity water flow that could erode heat exchangers.
- Unit air coil and filters:** Ensure that filter is clean and accessible. Clean air coil of all manufacturing oils.
- Unit controls:** Verify that CXM2 or DXM2.5 field selection options are properly set.

CAUTION

To avoid possible damage to a plastic (PVC) piping system, do not allow temperatures to exceed 110°F (43°C).

CAUTION

Verify that ALL water control valves are open and allow water flow prior to engaging the compressor. Freezing of the coax or water lines can permanently damage the heat pump.

CAUTION

To avoid equipment damage, DO NOT leave system filled in a building without heat during the winter unless antifreeze is added to the water loop. Heat exchangers never fully drain by themselves and will freeze unless winterized with antifreeze.

Unit Startup Procedures

NOTE: All Pre-Installation, Installation, Unit and System Checkout steps must be followed and completed before starting unit. Startup sequence and the number of steps may change for your installation. Follow all safety precautions. Fill out the Startup Log Sheet (in this manual) as steps are completed. Only a certified, licensed-service technician can perform startup and troubleshooting.

If operation in any mode has excessive noise or vibration, stop and correct. Check and repair any water leakage.

1. Adjust all valves to their full-open positions. Turn on the line power to all heat pumps.
2. Turn the thermostat-fan position to FAN ON. Blower should start. Verify all speeds function.
3. Balance air flow at registers.
4. Room temperature should be within the minimum-maximum ranges of Table 7 and Table 8 on page 77. During startup checks, loop-water temperature entering the heat pump should be between 60°F (16°C) and 95°F (35°C)
5. Set thermostat to off position
6. Remove return-air panel and open chassis-control box.
 - a. Turn on power, measure incoming high voltage at Compressor Contactor (CC), measure low voltage at board R and C.
 - b. Amp clamp black wire from CC1 T1.
 - c. Connect temperature thermocouples to entering and leaving water lines at the chassis. NOTE: units with DXM2.5 - EWT, LWT, LAT, discharge line, LT1, and LT2 temperatures can be read with service tool or at communicating thermostat
7. Inner panel and filter must be on chassis to block air from bypassing air coil. Bypass air will cause unit to fault off.
8. Check cooling mode (Reversing valve energized)
 - a. Set thermostat to cool and set temperature for 5 degrees lower than room temperature. It may take up to 5 minutes for compressor to start. Test mode reduces safety-time delay. Run 5 minutes minimum after compressor starts before recording data.
 - b. Air leaving should be 10 to 25°F (5.5 and 14°C) lower than entering air. Check air coil. If the humidity is over 50%, coil face should be damp but not icing up.
 - c. Water temperature leaving should be higher than entering, see Water Temperature Change table.
9. Check heating mode
 - a. Set thermostat to heat and set temperature for 5 degrees higher than room temperature. It may take up to 5 minutes for compressor to start. Test mode reduces safety-time delay. Run 5 minutes minimum after compressor starts before recording data.
 - b. Air leaving should be 20 to 30°F (11 and 17°C) higher than entering air.
 - c. Water temperature leaving should be lower than entering, see Water Temperature Change table.
10. When testing is completed
 - d. Set thermostat to owner's instructions.
 - e. Reassemble all parts.
11. Save Startup Log Sheet for future reference.
12. BE CERTAIN TO FILL OUT AND FORWARD ALL WARRANTY REGISTRATION PAPERS TO ClimateMaster.

NOTE: If performance during any mode appears abnormal, refer to the CXM2 and DXM2.5 sections or troubleshooting section of this manual. To obtain maximum performance, the air coil should be cleaned before startup. A 10% solution of dishwasher detergent and water is recommended.

WARNING

When the disconnect switch is closed, high voltage is present in some areas of the electrical panel. Exercise caution when working with energized equipment.

WARNING

Verify that ALL water-control valves are open and allow water flow prior to engaging the compressor. Freezing of the coax or water lines can permanently damage the heat pump.

Models:
SM
006-036

Unit Operating Conditions

Operating Pressure/Temperature tables include the following notes:

- Airflow is at nominal (rated) conditions
- Entering air is based upon 70°F [21°C] DB in heating and 80/67°F [27/19°C] in cooling
- Subcooling is based upon head pressure at compressor service port
- Cooling air and water values can vary greatly with changes in humidity level

SMS/SMT09	Water Flow GPM	Cooling										Heating							
		Suction Pressure PSIG	Discharge Pressure PSIG	Discharge Temp °F	LT1 Temp °F	LT2 Temp °F	Super-heat °F	Sub-cooling °F	Water Temp Rise °F	Air Temp Drop °F DB	Suction Pressure PSIG	Discharge Pressure PSIG	Discharge Temp °F	LT1 Temp °F	LT2 Temp °F	Super-heat °F	Sub-cooling °F	Water Temp Drop °F	Air Temp Rise °F DB
20	1.5	Operation Not Recommended																	
	2.25																		
	3.0																		
30	1.5	122 - 125	197 - 204	90 - 105	42 - 46	49 - 53	13 - 16	15 - 20	20 - 24	22 - 23	67 - 71	297 - 315	147 - 162	20 - 24	72 - 76	10 - 12	9 - 18	8 - 9	22 - 23
	2.25	116 - 119	177 - 184	86 - 101	38 - 42	48 - 52	17 - 19	15 - 18	13 - 16	21 - 22	71 - 75	301 - 321	146 - 161	22 - 26	73 - 77	10 - 12	10 - 19	6 - 7	23 - 24
	3.0	112 - 115	168 - 173	97 - 112	36 - 40	39 - 43	19 - 21	14 - 18	10 - 12	21 - 22	74 - 76	303 - 323	146 - 161	23 - 27	73 - 77	11 - 13	10 - 19	4 - 5	23 - 25
50	1.5	128 - 134	240 - 252	107 - 122	62 - 66	51 - 55	11 - 14	13 - 16	20 - 22	21 - 22	97 - 102	333 - 355	139 - 154	37 - 41	77 - 81	9 - 11	13 - 21	11 - 12	29 - 30
	2.25	122 - 131	219 - 233	102 - 117	59 - 63	51 - 55	12 - 17	12 - 16	13 - 15	21 - 22	104 - 108	339 - 361	139 - 154	40 - 44	79 - 83	9 - 11	13 - 21	8 - 9	30 - 31
	3.0	119 - 129	209 - 224	104 - 119	58 - 62	47 - 51	13 - 18	11 - 15	10 - 11	21 - 22	107 - 122	342 - 369	139 - 154	41 - 45	79 - 83	9 - 11	13 - 20	6 - 7	31 - 32
70	1.5	132 - 139	311 - 329	127 - 142	82 - 86	53 - 57	9 - 12	12 - 15	19 - 21	20 - 21	130 - 135	367 - 392	138 - 153	52 - 56	84 - 88	9 - 11	13 - 21	14 - 16	35 - 37
	2.25	131 - 137	287 - 306	121 - 136	80 - 84	53 - 57	10 - 13	10 - 12	13 - 14	20 - 21	139 - 144	375 - 402	138 - 153	55 - 59	85 - 89	10 - 11	13 - 20	10 - 12	37 - 38
	3.0	131 - 136	275 - 294	118 - 133	79 - 83	53 - 57	10 - 13	9 - 11	9 - 11	20 - 21	145 - 149	380 - 407	138 - 153	57 - 61	86 - 90	10 - 11	13 - 19	8 - 9	38 - 39
90	1.5	137 - 144	400 - 420	149 - 164	101 - 105	55 - 59	8 - 10	13 - 16	19 - 20	19 - 20	164 - 169	401 - 430	139 - 154	64 - 68	90 - 94	10 - 13	13 - 17	18 - 20	41 - 43
	2.25	135 - 142	373 - 395	142 - 157	99 - 103	55 - 59	9 - 11	10 - 12	12 - 14	19 - 20	175 - 178	411 - 442	141 - 156	68 - 72	92 - 96	12 - 16	14 - 17	12 - 14	43 - 45
	3.0	135 - 141	359 - 383	138 - 153	98 - 102	56 - 60	9 - 12	9 - 11	9 - 10	19 - 20	179 - 187	415 - 455	142 - 157	69 - 73	93 - 97	13 - 18	14 - 16	9 - 11	44 - 46
100	1.5	139 - 147	448 - 471	161 - 176	110 - 114	56 - 60	8 - 9	13 - 16	18 - 20	18 - 19	Operation Not Recommended								
	2.25	138 - 146	420 - 445	155 - 170	108 - 112	56 - 60	8 - 10	11 - 13	12 - 13	18 - 19									
	3.0	138 - 146	405 - 432	151 - 166	108 - 112	57 - 61	8 - 10	10 - 11	9 - 10	18 - 19									
120	1.5	144 - 153	549 - 583	186 - 201	128 - 132	58 - 62	7 - 8	15 - 17	17 - 19	17 - 18	Operation Not Recommended								
	2.25	143 - 153	525 - 557	181 - 196	126 - 130	58 - 62	7 - 8	12 - 14	11 - 13	17 - 18									
	3.0	143 - 152	511 - 543	180 - 195	126 - 130	57 - 61	8 - 9	11 - 13	9 - 10	17 - 18									

Unit Operating Conditions

SMS/SMT12	Water Flow GPM	Cooling										Heating							
		Suction Pressure PSIG	Discharge Pressure PSIG	Discharge Temp °F	LT1 Temp °F	LT2 Temp °F	Super-heat °F	Sub-cooling °F	Water Temp Rise °F	Air Temp Drop °F DB	Suction Pressure PSIG	Discharge Pressure PSIG	Discharge Temp °F	LT1 Temp °F	LT2 Temp °F	Super-heat °F	Sub-cooling °F	Water Temp Drop °F	Air Temp Rise °F DB
20	1.5	Operation Not Recommended																	
	2.25																		
	3.0																		
30	1.5	122 - 125	197 - 204	82 - 97	40 - 44	45 - 49	13 - 16	15 - 20	20 - 24	22 - 23	67 - 71	297 - 315	153 - 168	18 - 22	73 - 77	10 - 12	9 - 18	8 - 9	22 - 23
	2.25	116 - 119	177 - 184	77 - 92	37 - 41	44 - 48	17 - 19	15 - 18	13 - 16	21 - 22	71 - 75	301 - 321	151 - 166	21 - 25	74 - 78	10 - 12	10 - 19	6 - 7	23 - 24
	3.0	112 - 115	168 - 173	89 - 104	36 - 40	38 - 42	19 - 21	14 - 18	10 - 12	21 - 22	74 - 76	303 - 323	151 - 166	22 - 26	74 - 78	11 - 13	10 - 19	4 - 5	23 - 25
50	1.5	128 - 134	240 - 252	103 - 118	59 - 63	48 - 52	11 - 14	13 - 16	20 - 22	21 - 22	97 - 102	333 - 355	145 - 160	35 - 39	78 - 82	9 - 11	13 - 21	11 - 12	29 - 30
	2.25	122 - 131	219 - 233	97 - 112	57 - 61	47 - 51	12 - 17	12 - 16	13 - 15	21 - 22	104 - 108	339 - 361	144 - 159	39 - 43	79 - 83	9 - 11	13 - 21	8 - 9	30 - 31
	3.0	119 - 129	209 - 224	100 - 115	56 - 60	45 - 49	13 - 18	11 - 15	10 - 11	21 - 22	107 - 122	342 - 369	143 - 158	40 - 44	80 - 84	9 - 11	13 - 20	6 - 7	31 - 32
70	1.5	132 - 139	311 - 329	125 - 139	78 - 82	51 - 55	9 - 12	12 - 15	19 - 21	20 - 21	130 - 135	367 - 392	141 - 156	52 - 56	86 - 90	9 - 11	13 - 21	14 - 16	35 - 37
	2.25	131 - 137	287 - 306	119 - 134	76 - 80	50 - 54	10 - 13	10 - 12	13 - 14	20 - 21	139 - 144	375 - 402	141 - 156	56 - 60	88 - 92	10 - 11	13 - 20	10 - 12	37 - 38
	3.0	131 - 136	275 - 294	115 - 130	75 - 79	50 - 54	10 - 13	9 - 11	9 - 11	20 - 21	145 - 149	380 - 407	141 - 156	58 - 62	90 - 94	10 - 11	13 - 19	8 - 9	38 - 39
90	1.5	137 - 144	400 - 420	147 - 162	98 - 102	53 - 57	8 - 10	13 - 16	19 - 20	19 - 20	164 - 169	401 - 430	143 - 158	65 - 69	94 - 98	10 - 13	13 - 17	18 - 20	41 - 43
	2.25	135 - 142	373 - 395	141 - 156	96 - 100	53 - 57	9 - 11	10 - 12	12 - 14	19 - 20	175 - 178	411 - 442	143 - 158	70 - 74	99 - 103	12 - 16	14 - 17	12 - 14	43 - 45
	3.0	135 - 141	359 - 383	136 - 151	95 - 99	54 - 58	9 - 12	9 - 11	9 - 10	19 - 20	179 - 187	415 - 455	143 - 158	73 - 77	101 - 105	13 - 18	14 - 16	9 - 11	44 - 46
100	1.5	139 - 147	448 - 471	158 - 173	107 - 111	55 - 59	8 - 9	13 - 16	18 - 20	18 - 19	Operation Not Recommended								
	2.25	138 - 146	420 - 445	152 - 167	105 - 109	54 - 58	8 - 10	11 - 13	12 - 13	18 - 19									
	3.0	138 - 146	405 - 432	148 - 163	105 - 109	55 - 59	8 - 10	10 - 11	9 - 10	18 - 19									
120	1.5	144 - 153	549 - 583	181 - 196	126 - 130	57 - 61	7 - 8	15 - 17	17 - 19	17 - 18	Operation Not Recommended								
	2.25	143 - 153	525 - 557	175 - 190	125 - 129	57 - 61	7 - 8	12 - 14	11 - 13	17 - 18									
	3.0	143 - 152	511 - 543	176 - 191	124 - 128	56 - 60	8 - 9	11 - 13	9 - 10	17 - 18									

SMS/SMT15	Water Flow GPM	Cooling										Heating							
		Suction Pressure PSIG	Discharge Pressure PSIG	Discharge Temp °F	LT1 Temp °F	LT2 Temp °F	Super-heat °F	Sub-cooling °F	Water Temp Rise °F	Air Temp Drop °F DB	Suction Pressure PSIG	Discharge Pressure PSIG	Discharge Temp °F	LT1 Temp °F	LT2 Temp °F	Super-heat °F	Sub-cooling °F	Water Temp Drop °F	Air Temp Rise °F DB
20	1.5	Operation Not Recommended																	
	2.25																		
	3.0																		
30	1.5	122 - 125	197 - 204	105 - 120	38 - 42	46 - 50	13 - 16	15 - 20	20 - 24	22 - 23	67 - 71	297 - 315	150 - 165	20 - 24	76 - 80	10 - 12	9 - 18	8 - 9	22 - 23
	2.25	116 - 119	177 - 184	116 - 131	34 - 38	41 - 45	17 - 19	15 - 18	13 - 16	21 - 22	71 - 75	301 - 321	149 - 164	22 - 26	76 - 80	10 - 12	10 - 19	6 - 7	23 - 24
	3.0	112 - 115	168 - 173	113 - 128	36 - 40	36 - 40	19 - 21	14 - 18	10 - 12	21 - 22	74 - 76	303 - 323	149 - 164	23 - 27	76 - 80	11 - 13	10 - 19	4 - 5	23 - 25
50	1.5	128 - 134	240 - 252	114 - 129	61 - 65	49 - 53	11 - 14	13 - 16	20 - 22	21 - 22	97 - 102	333 - 355	148 - 163	36 - 40	80 - 84	9 - 11	13 - 21	11 - 12	29 - 30
	2.25	122 - 131	219 - 233	117 - 132	57 - 61	47 - 51	12 - 17	12 - 16	13 - 15	21 - 22	104 - 108	339 - 361	148 - 163	38 - 42	80 - 84	9 - 11	13 - 21	8 - 9	30 - 31
	3.0	119 - 129	209 - 224	117 - 132	57 - 61	44 - 48	13 - 18	11 - 15	10 - 11	21 - 22	107 - 122	342 - 369	149 - 164	39 - 43	80 - 84	9 - 11	13 - 20	6 - 7	31 - 32
70	1.5	132 - 139	311 - 329	128 - 143	82 - 86	53 - 57	9 - 12	12 - 15	19 - 21	20 - 21	130 - 135	367 - 392	148 - 163	48 - 52	85 - 89	9 - 11	13 - 21	14 - 16	35 - 37
	2.25	131 - 137	287 - 306	126 - 141	79 - 83	51 - 55	10 - 13	10 - 12	13 - 14	20 - 21	139 - 144	375 - 402	149 - 164	51 - 55	86 - 90	10 - 11	13 - 20	10 - 12	37 - 38
	3.0	131 - 136	275 - 294	126 - 141	78 - 82	51 - 55	10 - 13	9 - 11	9 - 11	20 - 21	145 - 149	380 - 407	150 - 165	52 - 56	86 - 90	10 - 11	13 - 19	8 - 9	38 - 39
90	1.5	137 - 144	400 - 420	147 - 162	101 - 105	56 - 60	8 - 10	13 - 16	19 - 20	19 - 20	164 - 169	401 - 430	152 - 167	59 - 63	91 - 95	10 - 13	13 - 17	18 - 20	41 - 43
	2.25	135 - 142	373 - 395	142 - 157	99 - 103	55 - 59	9 - 11	10 - 12	12 - 14	19 - 20	175 - 178	411 - 442	154 - 169	62 - 66	92 - 96	12 - 16	14 - 17	12 - 14	43 - 45
	3.0	135 - 141	359 - 383	142 - 157	98 - 102	55 - 59	9 - 12	9 - 11	9 - 10	19 - 20	179 - 187	415 - 455	155 - 170	64 - 68	92 - 96	13 - 18	14 - 16	9 - 11	44 - 46
100	1.5	139 - 147	448 - 471	158 - 173	110 - 114	57 - 61	8 - 9	13 - 16	18 - 20	18 - 19	Operation Not Recommended								
	2.25	138 - 146	420 - 445	153 - 168	109 - 103	57 - 61	8 - 10	11 - 13	12 - 13	18 - 19									
	3.0	138 - 146	405 - 432	152 - 167	107 - 101	56 - 60	8 - 10	10 - 11	9 - 10	18 - 19									
120	1.5	144 - 153	549 - 583	185 - 200	128 - 132	59 - 63	7 - 8	15 - 17	17 - 19	17 - 18	Operation Not Recommended								
	2.25	143 - 153	525 - 557	180 - 195	127 - 131	59 - 63	7 - 8	12 - 14	11 - 13	17 - 18									
	3.0	143 - 152	511 - 543	177 - 192	127 - 131	57 - 61	8 - 9	11 - 13	9 - 10	17 - 18									

TRANQUILITY® (SM) VERTICAL STACK SERIES- IOM

Models:
SM
006-036

Unit Operating Conditions

SMS/SMT18	Water Flow GPM	Cooling										Heating							
		Suction Pressure PSIG	Discharge Pressure PSIG	Discharge Temp °F	LT1 Temp °F	LT2 Temp °F	Super-heat °F	Sub-cooling °F	Water Temp Rise °F	Air Temp Drop °F DB	Suction Pressure PSIG	Discharge Pressure PSIG	Discharge Temp °F	LT1 Temp °F	LT2 Temp °F	Super-heat °F	Sub-cooling °F	Water Temp Drop °F	Air Temp Rise °F DB
20	1.5	Operation Not Recommended																	
	2.25																		
	3.0																		
30	1.5	122 - 125	197 - 204	105 - 120	38 - 42	46 - 50	13 - 16	15 - 20	20 - 24	22 - 23	67 - 71	297 - 315	150 - 165	20 - 24	74 - 80	10 - 12	9 - 18	8 - 9	22 - 23
	2.25	116 - 119	177 - 184	116 - 131	34 - 38	41 - 45	17 - 19	15 - 18	13 - 16	21 - 22	71 - 75	301 - 321	149 - 164	22 - 26	76 - 80	10 - 12	10 - 19	6 - 7	23 - 24
	3.0	112 - 115	168 - 173	113 - 128	36 - 40	36 - 40	19 - 21	14 - 18	10 - 12	21 - 22	74 - 76	303 - 323	149 - 164	23 - 27	76 - 80	11 - 13	10 - 19	4 - 5	23 - 25
50	1.5	128 - 134	240 - 252	114 - 129	61 - 65	49 - 53	11 - 14	13 - 16	20 - 22	21 - 22	97 - 102	333 - 355	148 - 163	36 - 40	80 - 84	9 - 11	13 - 21	11 - 12	29 - 30
	2.25	122 - 131	219 - 233	117 - 132	57 - 61	47 - 51	12 - 17	12 - 16	13 - 15	21 - 22	104 - 108	339 - 361	148 - 163	38 - 42	80 - 84	9 - 11	13 - 21	8 - 9	30 - 31
	3.0	119 - 129	209 - 224	117 - 132	57 - 61	44 - 48	13 - 18	11 - 15	10 - 11	21 - 22	107 - 122	342 - 369	149 - 164	39 - 43	80 - 84	9 - 11	13 - 20	6 - 7	31 - 32
70	1.5	132 - 139	311 - 329	128 - 143	82 - 86	53 - 57	9 - 12	12 - 15	19 - 21	20 - 21	130 - 135	367 - 392	148 - 163	48 - 52	85 - 89	9 - 11	13 - 21	14 - 16	35 - 37
	2.25	131 - 137	287 - 306	126 - 141	79 - 83	51 - 55	10 - 13	10 - 12	13 - 14	20 - 21	139 - 144	375 - 402	149 - 164	51 - 55	86 - 90	10 - 11	13 - 20	10 - 12	37 - 38
	3.0	131 - 136	275 - 294	126 - 141	78 - 82	51 - 55	10 - 13	9 - 11	9 - 11	20 - 21	145 - 149	380 - 407	150 - 165	52 - 56	86 - 90	10 - 11	13 - 19	8 - 9	38 - 39
90	1.5	137 - 144	400 - 420	147 - 162	101 - 105	56 - 60	8 - 10	13 - 16	19 - 20	19 - 20	164 - 169	401 - 430	152 - 167	59 - 63	91 - 95	10 - 13	13 - 17	18 - 20	41 - 43
	2.25	135 - 142	373 - 395	142 - 157	99 - 103	55 - 59	9 - 11	10 - 12	12 - 14	19 - 20	175 - 178	411 - 442	154 - 169	62 - 66	92 - 96	12 - 16	14 - 17	12 - 14	43 - 45
	3.0	135 - 141	359 - 383	142 - 157	98 - 102	55 - 59	9 - 12	9 - 11	9 - 10	19 - 20	179 - 187	415 - 455	155 - 170	64 - 68	92 - 96	13 - 18	14 - 16	9 - 11	44 - 46
100	1.5	139 - 147	448 - 471	158 - 173	110 - 114	57 - 61	8 - 9	13 - 16	18 - 20	18 - 19	Operation Not Recommended								
	2.25	138 - 146	420 - 445	153 - 168	109 - 103	57 - 61	8 - 10	11 - 13	12 - 13	18 - 19									
	3.0	138 - 146	405 - 432	152 - 167	107 - 101	56 - 60	8 - 10	10 - 11	9 - 10	18 - 19									
120	1.5	144 - 153	549 - 583	185 - 200	128 - 132	59 - 63	7 - 8	15 - 17	17 - 19	17 - 18	Operation Not Recommended								
	2.25	143 - 153	525 - 557	180 - 195	127 - 131	59 - 63	7 - 8	12 - 14	11 - 13	17 - 18									
	3.0	143 - 152	511 - 543	177 - 192	127 - 131	57 - 61	8 - 9	11 - 13	9 - 10	17 - 18									

SMS/SMT24	Water Flow GPM	Cooling										Heating							
		Suction Pressure PSIG	Discharge Pressure PSIG	Discharge Temp °F	LT1 Temp °F	LT2 Temp °F	Super-heat °F	Sub-cooling °F	Water Temp Rise °F	Air Temp Drop °F DB	Suction Pressure PSIG	Discharge Pressure PSIG	Discharge Temp °F	LT1 Temp °F	LT2 Temp °F	Super-heat °F	Sub-cooling °F	Water Temp Drop °F	Air Temp Rise °F DB
20	1.5	Operation Not Recommended																	
	2.25																		
	3.0																		
30	1.5	122 - 125	197 - 204	78 - 93	35 - 39	46 - 50	13 - 16	15 - 20	20 - 24	22 - 23	67 - 71	297 - 315	145 - 160	15 - 19	74 - 78	9 - 12	8 - 17	3 - 4	20 - 22
	2.25	116 - 119	177 - 184	76 - 91	38 - 42	45 - 49	17 - 19	15 - 18	13 - 16	21 - 22	71 - 75	301 - 321	144 - 159	22 - 26	75 - 79	10 - 12	10 - 19	6 - 7	23 - 24
	3.0	112 - 115	168 - 173	94 - 109	37 - 41	39 - 43	19 - 21	14 - 18	10 - 12	21 - 22	74 - 76	303 - 323	144 - 159	23 - 27	76 - 80	11 - 13	10 - 19	4 - 5	23 - 25
50	1.5	128 - 134	240 - 252	98 - 113	57 - 61	50 - 54	11 - 14	13 - 16	20 - 22	21 - 22	97 - 102	333 - 355	142 - 157	38 - 42	81 - 85	9 - 11	13 - 21	11 - 12	29 - 30
	2.25	122 - 131	219 - 233	94 - 109	56 - 60	49 - 53	12 - 17	12 - 16	13 - 15	21 - 22	104 - 108	339 - 361	142 - 157	40 - 44	82 - 86	9 - 11	13 - 21	8 - 9	30 - 31
	3.0	119 - 129	209 - 224	99 - 114	56 - 60	47 - 51	13 - 18	11 - 15	10 - 11	21 - 22	107 - 122	342 - 369	142 - 157	42 - 46	82 - 86	9 - 11	13 - 20	6 - 7	31 - 32
70	1.5	132 - 139	311 - 329	120 - 135	77 - 81	53 - 57	9 - 12	12 - 15	19 - 21	20 - 21	130 - 135	367 - 392	144 - 159	53 - 57	88 - 92	9 - 11	13 - 21	14 - 16	35 - 37
	2.25	131 - 137	287 - 306	115 - 130	76 - 80	53 - 57	10 - 13	10 - 12	13 - 14	20 - 21	139 - 144	375 - 402	145 - 160	56 - 60	90 - 94	10 - 11	13 - 20	10 - 12	37 - 38
	3.0	131 - 136	275 - 294	113 - 128	76 - 80	53 - 57	10 - 13	9 - 11	9 - 11	20 - 21	145 - 149	380 - 407	146 - 161	57 - 61	90 - 94	10 - 11	13 - 19	8 - 9	38 - 39
90	1.5	137 - 144	400 - 420	145 - 160	97 - 101	56 - 60	8 - 10	13 - 16	19 - 20	19 - 20	164 - 169	401 - 430	145 - 160	68 - 72	98 - 102	10 - 13	13 - 17	18 - 20	41 - 43
	2.25	135 - 142	373 - 395	140 - 155	95 - 99	53 - 57	9 - 11	10 - 12	12 - 14	19 - 20	175 - 178	411 - 442	147 - 162	71 - 75	100 - 104	12 - 16	14 - 17	12 - 14	43 - 45
	3.0	135 - 141	359 - 383	135 - 150	94 - 98	57 - 61	9 - 12	9 - 11	9 - 10	19 - 20	179 - 187	415 - 455	148 - 163	73 - 77	101 - 105	13 - 18	14 - 16	9 - 11	44 - 46
100	1.5	139 - 147	448 - 471	159 - 174	106 - 110	57 - 61	8 - 9	13 - 16	18 - 20	18 - 19	Operation Not Recommended								
	2.25	138 - 146	420 - 445	153 - 168	104 - 108	56 - 60	8 - 10	11 - 13	12 - 13	18 - 19									
	3.0	138 - 146	405 - 432	149 - 164	104 - 108	57 - 61	8 - 10	10 - 11	9 - 10	18 - 19									
120	1.5	144 - 153	549 - 583	188 - 203	123 - 127	58 - 62	7 - 8	15 - 17	17 - 19	17 - 18	Operation Not Recommended								
	2.25	143 - 153	525 - 557	183 - 198	122 - 126	58 - 62	7 - 8	12 - 14	11 - 13	17 - 18									
	3.0	143 - 152	511 - 543	183 - 198	122 - 126	57 - 61	8 - 9	11 - 13	9 - 10	17 - 18									

Unit Operating Conditions

SMS/SMT30	Water Flow GPM	Cooling										Heating							
		Suction Pressure PSIG	Discharge Pressure PSIG	Discharge Temp °F	LT1 Temp °F	LT2 Temp °F	Super-heat °F	Sub-cooling °F	Water Temp Rise °F	Air Temp Drop °F DB	Suction Pressure PSIG	Discharge Pressure PSIG	Discharge Temp °F	LT1 Temp °F	LT2 Temp °F	Super-heat °F	Sub-cooling °F	Water Temp Drop °F	Air Temp Rise °F DB
20	1.5	Operation Not Recommended																	
	2.25																		
	3.0																		
30	1.5	116 - 118	160 - 165	102 - 117	42 - 46	46 - 50	13 - 16	14 - 16	18 - 20	22 - 23	72 - 75	297 - 315	157 - 172	19 - 23	90 - 94	10 - 12	4 - 6	7 - 9	19 - 20
	2.25	113 - 116	150 - 155	115 - 130	37 - 41	43 - 47	17 - 19	14 - 16	11 - 13	21 - 22	75 - 78	301 - 321	156 - 171	21 - 25	91 - 95	10 - 12	4 - 6	6 - 7	20 - 22
	3.0	104 - 107	145 - 150	117 - 132	36 - 40	39 - 43	19 - 21	14 - 16	9 - 11	19 - 21	78 - 82	303 - 323	155 - 170	23 - 27	91 - 95	11 - 13	4 - 6	4 - 5	20 - 22
50	1.5	128 - 132	215 - 225	111 - 126	63 - 67	50 - 54	15 - 18	13 - 16	20 - 22	21 - 22	104 - 110	333 - 355	150 - 165	35 - 39	96 - 100	9 - 11	6 - 7	10 - 11	26 - 28
	2.25	122 - 127	200 - 210	115 - 130	59 - 63	48 - 52	19 - 21	11 - 14	11 - 13	21 - 22	108 - 114	336 - 358	150 - 165	38 - 42	97 - 101	11 - 13	6 - 7	8 - 9	26 - 28
	3.0	119 - 125	195 - 205	116 - 131	57 - 61	46 - 50	18 - 20	12 - 15	9 - 11	21 - 22	107 - 113	333 - 355	150 - 165	39 - 43	97 - 101	9 - 11	6 - 7	6 - 7	26 - 28
70	1.5	132 - 139	293 - 303	127 - 142	82 - 86	54 - 58	9 - 12	10 - 12	18 - 20	20 - 21	132 - 137	359 - 369	150 - 165	49 - 53	103 - 107	12 - 14	6 - 7	14 - 16	32 - 34
	2.25	131 - 136	273 - 283	124 - 139	80 - 84	53 - 57	10 - 13	9 - 11	12 - 14	20 - 21	139 - 144	366 - 376	151 - 166	52 - 56	104 - 108	14 - 16	6 - 7	10 - 12	32 - 34
	3.0	132 - 137	263 - 273	124 - 139	78 - 82	52 - 56	13 - 15	9 - 11	9 - 11	20 - 21	144 - 148	374 - 384	153 - 168	53 - 57	105 - 109	14 - 16	6 - 7	8 - 9	32 - 34
90	1.5	137 - 144	358 - 368	149 - 164	101 - 105	57 - 61	10 - 11	10 - 12	16 - 18	19 - 20	164 - 169	395 - 405	160 - 175	57 - 61	106 - 110	20-24	7 - 8	16	35 - 37
	2.25	136 - 142	335 - 345	142 - 157	99 - 103	56 - 60	9 - 11	10 - 12	12 - 14	19 - 20	173 - 178	403 - 413	164 - 179	59 - 63	107 - 111	22-26	8 - 9	10 - 12	36 - 38
	3.0	134 - 140	328 - 338	141 - 156	97 - 101	56 - 60	10 - 12	9 - 11	9 - 10	19 - 20	179 - 187	415 - 425	166 - 181	60 - 64	107 - 111	24-28	9 - 10	9 - 11	36 - 38
100	1.5	143 - 148	430 - 440	163 - 178	110 - 114	58 - 62	8 - 9	10 - 12	18 - 20	18 - 19	Operation Not Recommended								
	2.25	142 - 147	407 - 417	155 - 170	109 - 113	58 - 62	8 - 10	8 - 10	13 - 15	18 - 19									
	3.0	141 - 146	395 - 405	153 - 168	107 - 111	58 - 62	9 - 11	7 - 9	9 - 10	18 - 19									
120	1.5	148 - 152	533 - 543	195 - 210	127 - 131	61 - 65	9 - 11	9 - 11	15 - 17	17 - 18	Operation Not Recommended								
	2.25	150 - 155	513 - 523	187 - 202	126 - 130	61 - 65	8 - 10	7 - 9	10 - 12	17 - 18									
	3.0	147 - 152	502 - 512	183 - 198	125 - 129	60 - 64	9 - 11	7 - 9	8 - 10	17 - 18									

SMS/SMT36	Water Flow GPM	Cooling										Heating							
		Suction Pressure PSIG	Discharge Pressure PSIG	Discharge Temp °F	LT1 Temp °F	LT2 Temp °F	Super-heat °F	Sub-cooling °F	Water Temp Rise °F	Air Temp Drop °F DB	Suction Pressure PSIG	Discharge Pressure PSIG	Discharge Temp °F	LT1 Temp °F	LT2 Temp °F	Super-heat °F	Sub-cooling °F	Water Temp Drop °F	Air Temp Rise °F DB
20	1.5	Operation Not Recommended																	
	2.25																		
	3.0																		
30	1.5	121 - 125	197 - 207	100 - 115	41 - 45	44 - 48	14 - 17	15 - 18	17 - 19	20 - 22	69 - 73	295 - 305	153 - 168	20 - 24	90 - 94	8 - 11	2 - 4	8 - 10	20 - 22
	2.25	119 - 123	174 - 184	96 - 111	38 - 42	44 - 48	16 - 19	15 - 18	12 - 14	21 - 23	73 - 76	295 - 305	152 - 167	23 - 27	91 - 95	8 - 11	3 - 5	4 - 6	19 - 22
	3.0	118 - 122	157 - 163	97 - 112	37 - 41	40 - 44	16 - 19	14 - 17	10 - 12	22 - 25	78 - 82	295 - 305	151 - 166	24 - 28	92 - 96	8 - 11	3 - 5	4 - 6	19 - 22
50	1.5	128 - 132	243 - 253	114 - 129	59 - 63	48 - 52	9 - 12	19 - 22	20 - 22	19 - 21	97 - 102	325 - 335	149 - 164	37 - 41	95 - 99	9 - 12	4 - 6	11 - 13	26 - 28
	2.25	126 - 130	226 - 236	108 - 123	57 - 61	47 - 51	9 - 12	16 - 19	15 - 19	22 - 24	104 - 108	329 - 339	149 - 164	39 - 43	96 - 100	8 - 11	4 - 6	10 - 12	17 - 19
	3.0	130 - 134	213 - 223	107 - 122	56 - 60	46 - 50	12 - 15	12 - 15	9 - 11	22 - 24	108 - 112	334 - 344	149 - 164	41 - 45	97 - 101	9 - 12	4 - 6	6 - 8	28 - 30
70	1.5	132 - 136	228 - 238	135 - 150	78 - 82	51 - 55	9 - 12	18 - 21	21 - 23	19 - 21	131 - 136	359 - 369	149 - 164	51 - 55	102 - 106	9 - 12	3 - 5	14 - 16	31 - 33
	2.25	133 - 137	297 - 307	128 - 143	76 - 80	51 - 55	9 - 12	17 - 19	16 - 19	20 - 22	138 - 142	366 - 376	150 - 165	55 - 59	104 - 108	10 - 13	3 - 5	6 - 8	34 - 36
	3.0	132 - 134	287 - 297	125 - 140	75 - 79	51 - 55	10 - 13	14 - 17	9 - 11	21 - 23	144 - 148	374 - 384	151 - 166	57 - 61	105 - 109	10 - 13	3 - 5	8 - 10	35 - 37
90	1.5	137 - 144	400 - 420	163 - 178	96 - 100	55 - 59	8 - 10	13 - 16	19 - 20	19 - 20	164 - 169	395 - 405	153 - 168	64 - 68	110 - 114	10 - 13	3 - 5	18 - 20	39 - 41
	2.25	135 - 142	373 - 395	155 - 170	94 - 98	54 - 58	9 - 11	10 - 12	12 - 14	19 - 20	173 - 178	403 - 413	155 - 170	68 - 72	113 - 117	12 - 15	3 - 5	14 - 16	41 - 43
	3.0	135 - 141	359 - 383	151 - 166	93 - 97	54 - 58	9 - 12	9 - 11	9 - 10	19 - 20	179 - 187	415 - 425	156 - 171	71 - 75	114 - 118	13 - 18	3 - 5	9 - 11	42 - 44
100	1.5	139 - 147	450 - 460	180 - 195	105 - 109	56 - 60	8 - 9	20 - 23	14 - 16	19 - 20	Operation Not Recommended								
	2.25	138 - 146	420 - 445	171 - 186	104 - 108	56 - 60	8 - 10	11 - 13	12 - 13	18 - 19									
	3.0	138 - 146	405 - 432	166 - 181	103 - 107	56 - 60	8 - 10	10 - 11	9 - 10	18 - 19									
120	1.5	144 - 153	560 - 590	218 - 233	123 - 127	59 - 63	6 - 8	15 - 17	17 - 19	17 - 18	Operation Not Recommended								
	2.25	143 - 153	540 - 560	208 - 223	122 - 126	58 - 62	6 - 8	12 - 14	11 - 13	17 - 18									
	3.0	143 - 152	535 - 565	203 - 218	121 - 125	58 - 62	6 - 8	17 - 20	10 - 12	18 - 19									

Models:
SM
006-036

Coax Water-Pressure Drop

Model	GPM	Pressure Drop, PSI				PD Added for Add for MWV
		30°F	50°F	70°F	90°F	
SM*06	1.1	1.2	1.0	0.8	0.7	0.7
	1.7	2.7	1.9	1.8	1.6	1.6
	2.3	4.5	3.1	2.9	2.8	2.6
SM*09	1.1	1.2	1.0	0.8	0.7	0.7
	1.7	2.7	1.9	1.8	1.6	1.6
	2.3	4.5	3.1	2.9	2.8	2.6
SM*12	1.5	2.1	1.5	1.4	1.3	1.3
	2.3	4.3	3.1	2.9	2.8	2.6
	3.0	7.0	5.1	4.8	4.6	4.4
SM*15	1.9	0.6	0.4	0.4	0.3	0.3
	2.8	1.4	0.9	0.8	0.7	0.7
	3.8	2.3	1.4	1.3	1.2	1.1
SM*18	2.3	0.6	0.4	0.4	0.4	0.3
	3.4	1.6	1.1	1.0	0.9	0.9
	4.5	2.8	2.0	1.8	1.6	1.5
SM*24	3.0	1.0	0.7	0.7	0.6	0.6
	4.5	2.1	1.5	1.4	1.2	1.2
	6.0	3.6	2.4	2.2	2.1	1.9
SM*30	3.8	1.3	1.0	0.9	0.8	0.8
	5.6	2.9	2.0	1.9	1.8	1.7
	7.5	5.0	3.4	3.2	3.1	2.8
SM*36	4.5	1.8	1.4	1.3	1.1	1.0
	6.8	3.6	2.8	2.5	2.2	2.0
	9.0	5.9	4.5	4.0	3.6	3.3

Startup Log Sheet

7300 S.W. 44th Street, Oklahoma City, OK 73179 • Phone: 1-800-299-9747

Installer: Complete *Unit and System Checkout* and follow *Unit Startup Procedures* in the IOM. Use this form to record unit information, temperatures, and pressures during startup. Keep this form for reference.

Job Name: _____

Street Address: _____

Chassis Model Number: _____ **Serial Number:** _____

Cabinet Model Number: _____ **Serial Number:** _____

Unit Location in Building: _____

Date: _____ **Sales Order Number:** _____

In order to minimize troubleshooting and costly system failures, complete the following checks and data entries before the system is put into full operation.

Fan Motor	Description	Value
PSC	Speed Tap	
CT EC	Speed Tap	
CV EC	CFM Setting	

Temperatures (check one): °F °C Antifreeze: _____ %

Pressures (check one): PSIG kPa Type: _____

	Cooling Mode	Heating Mode
Temperatures		
Entering Fluid Temperature		
Leaving Fluid Temperature		
Fluid Temperature Differential		
Return-Air Temperature	DB	DB
Supply-Air Temperature	DB	DB
Air Temperature Differential		
LT1		
LT2		
Discharge Line		
Leaving Air		
Voltages		
Supply at Unit		
Transformer Low Side		
Amps		
Compressor		

- NOTES:**
1. Allow unit to run 15 minutes in each mode before taking data.
 2. Never connect refrigerant gauges during startup procedures.
 3. Conduct water-side analysis using P/T ports to determine water flow and temperature difference.
 4. If water-side analysis shows poor performance, refrigerant troubleshooting may be required.
 5. Connect refrigerant gauges as a last resort.

Preventive Maintenance

WATER COIL MAINTENANCE (WATER LOOP APPLICATIONS)

Generally water coil maintenance is not needed for closed loop systems. However, if the piping is known to have high dirt or debris content, it is best to establish a periodic maintenance schedule with the owner so the water coil can be checked regularly. Dirty installations are typically the result of deterioration of iron or galvanized piping or components in the system. Open cooling towers requiring heavy chemical treatment and mineral buildup through water use can also contribute to higher maintenance. Should periodic coil cleaning be necessary, use standard coil cleaning procedures, which are compatible with both the heat exchanger material and copper water lines. Generally, the more water flowing through the unit, the less chance for scaling. However, flow rates over 3 GPM per ton (3.9 l/m per kW) can produce water (or debris) velocities that can erode the heat exchanger wall and ultimately produce leaks.

FILTERS

Filters must be clean to obtain maximum performance. Filters should be inspected every month under normal operating conditions and be replaced when necessary. Units should never be operated without a filter.

CONDENSATE DRAIN

In areas where airborne bacteria may produce a “slimy” substance in the drain pan, it may be necessary to treat the drain pan chemically with an algaecide approximately every three months to minimize the problem. The condensate pan may also need to be cleaned periodically to ensure indoor air quality. The condensate drain can pick up lint and dirt, especially with dirty filters. Inspect the drain twice a year to avoid the possibility of plugging and eventual overflow.

COMPRESSOR

Conduct annual amperage checks to ensure that amp draw is no more than 10% greater than indicated on the serial plate data.

AIR COIL

The air coil must be cleaned to obtain maximum performance. Check once a year under normal operating conditions and, if dirty, brush or vacuum clean. Care must be taken not to damage the aluminum fins while cleaning. CAUTION: Fin edges are sharp.

CABINET

Check inside cabinet once a year. Gently brush or vacuum clean if needed. Do not tear insulation, repair with foil tape.

REFRIGERANT SYSTEM

To maintain sealed circuit integrity, do not install service gauges unless unit operation appears abnormal. Reference the operating charts for pressures and temperatures. Verify that air and water-flow rates are at proper levels before servicing the refrigerant circuit.

All product families have transitioned to CoreMax® high flow service valves. In place of Schrader ports.

The CoreMax® system:

- Permits up to six times higher flow rate to substantially reduce refrigerant recovery and evacuation time
- Maintains compatibility with ¼-inch flare and standard-refrigeration hose connections
- Has lower leak rates than the traditional refrigerant valve/access fittings
- Requires a special tool (FasTest - SCFT20A) to replace the valve core without reclaiming, evacuating and recharging the system. The tool can be purchased directly from FasTest or check with your local supply house.

For additional information, please contact our Customer Experience team.

REPAIRS TO SEALED COMPONENTS

Sealed electrical components shall be replaced.

Functional Troubleshooting

Models:
SM
006-036

Fault	Htg	Cig	Possible Cause	Solution
Main power problems	X	X	Green Status LED Off	Check line voltage circuit breaker and disconnect.
				Check for line voltage between L1 and L2 on the contactor.
				Check for 24VAC between R and C on CXM2/DXM2.5.
				Check primary/secondary voltage on transformer.
HP Fault Code 2 High Pressure		X	Reduced or no water flow in cooling	Check pump operation or valve operation/setting. Check water flow adjust to proper flow rate.
		X	Water Temperature out of range in cooling	Bring water temp within design parameters.
	X		Reduced or no airflow in heating	Check for dirty air filter and clean or replace.
				Check fan motor operation and airflow restrictions.
				Dirty Air Coil - construction dust etc.
				Too high of external static? Check static vs blower table.
	X		Air temperature out of range in heating	Bring return air temp within design parameters.
	X	X	Overcharged with refrigerant	Check superheat/subcooling vs typical operating condition table.
X	X	Bad HP Switch	Check switch continuity and operation. Replace.	
LP/LOC Fault Code 3 Low Pressure / Loss of Charge	X	X	Insufficient charge	Check for refrigerant leaks.
	X		Compressor pump down at startup	Check charge and startup water flow.
LT1 Fault Code 4 Water coil low temperature limit	X		Reduced or no water flow in heating	Check pump operation or water valve operation/setting.
				Plugged strainer or filter? Clean or replace.
				Check water flow. Adjust to proper flow rate.
	X		Inadequate antifreeze level	Check antifreeze density with hydrometer.
	X		Improper temperature limit setting (30°F vs 10°F [-1°C vs -2°C])	Clip JW3 jumper for antifreeze (10°F [-12°C]) use.
	X		Water Temperature out of range	Bring water temp within design parameters.
X	X	Bad thermistor	Check temp and impedance correlation per chart.	
LT2 Fault Code 5 Air coil low temperature limit		X	Reduced or no airflow in cooling	Check for dirty air filter and clean or replace.
				Check fan motor operation and airflow restrictions.
				Too high of external static? Check static vs blower table.
		X	Air Temperature out of range	Too much cold vent air? Bring entering air temp within design parameters.
		X	Improper temperature limit setting (30°F vs 10°F [-1°C vs -12°C])	Normal airside applications will require 30°F [-1°C] only.
Condensate Fault Code 6	X	X	Blocked drain	Check for blockage and clean drain.
	X	X	Improper trap	Check trap dimensions and location ahead of vent.
		X	Poor drainage	Check for piping slope away from unit.
				Check slope of unit toward outlet.
				Poor venting? Check vent location.
		X	Moisture on sensor	Check for moisture shorting to air coil.
	X	X	Plugged air filter	Replace air filter.
X	X	Restricted Return Airflow	Find and eliminate restriction. Increase return duct and/or grille size.	

Table continued on next page.

Models:
SM
006-036

Functional Troubleshooting

Table continued from previous page.

Fault	Htg	Clg	Possible Cause	Solution
Over/Under Voltage Code 7 (Auto resetting)	X	X	Under Voltage	Check power supply and 24VAC voltage before and during operation.
				Check power supply wire size.
	X	X	Over Voltage	Check compressor starting. Need hard start kit?
				Check 24VAC and unit transformer. Tap for correct power supply voltage.
Unit Performance Sentinel Code 8	X		Heating mode LT2>125°F [52°C]	Check power supply voltage and 24VAC before and during operation.
		X	Cooling Mode LT1>125°F [52°C] OR LT2< 40°F [4°C]	Check 24VAC and unit transformer. Tap for correct power supply voltage.
Swapped Thermistor Code 9	X	X	LT1 and LT2 swapped	Check for poor airflow or overcharged unit.
Refrigerant and RDS Code 15	X	X	Refrigerant Leak	Check for poor water flow or airflow.
			Faulty RDS sensor	Check refrigerant charge. If the charge is low, identify and repair the leak.
No Fault Code Shown	X	X	No compressor operation	Check refrigerant charge. If the charge is not low, replace the RDS sensor.
	X	X	Compressor overload	See "Only Fan Operates".
	X	X	Control board	Check and replace, if necessary.
Unit Short Cycles	X	X	Dirty air filter	Reset power and check operation.
	X	X	Unit in "test mode"	Check and clean air filter.
	X	X	Unit selection	Reset power or wait 20 minutes for auto exit.
	X	X	Compressor overload	Unit may be oversized for space. Check sizing for actual load of space.
Only Fan Runs	X	X	Thermostat position	Check and replace, if necessary.
	X	X	Unit locked out	Ensure thermostat set for heating or cooling operation.
	X	X	Compressor Overload	Check for lockout codes. Reset power.
	X	X	Thermostat wiring	Check compressor overload. Replace if necessary.
Only Compressor Runs	X	X	Thermostat wiring	Check thermostat wiring at heat pump. Jumper Y and R for compressor operation in test mode.
	X	X		Check G wiring at heat pump. Jumper G and R for fan operation.
	X	X	Fan motor relay	Check thermostat wiring at heat pump. Jumper Y and R for compressor operation in test mode.
	X	X		Jumper G and R for fan operation. Check for line voltage across BR contacts.
	X	X	Fan motor	Check fan power enable relay operation (if present).
Unit Doesn't Operate in Cooling		X	Reversing valve	Check for line voltage at motor. Check capacitor.
		X		Set for cooling demand and check 24VAC on RV coil and at CXM2/DXM2.5 board.
		X	Thermostat setup	If RV is stuck, run high pressure up by reducing water flow and while operating engage and disengage RV coil voltage to push valve.
		X	Thermostat wiring	Check for 'O' RV setup not 'B'.
		X		Check O wiring at heat pump. Jumper O and R for RV coil 'click'.
		X		Put thermostat in cooling mode. Check 24VAC on O (check between C and O); check for 24VAC on W (check between W and C). There should be voltage on O, but not on W. If voltage is present on W, thermostat may be bad or wired incorrectly.

Performance Troubleshooting

Symptom	Htg	Cig	Possible Cause	Solution
Insufficient capacity/ Not cooling or heating	X	X	Dirty filter	Replace or clean.
	X		Reduced or no airflow in heating	Check for dirty air filter and clean or replace.
				Check fan motor operation and airflow restrictions.
				Too high of external static? Check static vs. blower table.
		X	Reduced or no airflow in cooling	Check for dirty air filter and clean or replace.
				Check fan motor operation and airflow restrictions.
				Too high of external static? Check static vs. blower table.
	X	X	Leaky duct work	Check supply and return air temperatures at the unit and at distant duct registers. If significantly different, duct leaks are present.
	X	X	Low refrigerant charge	Check superheat and subcooling per chart.
	X	X	Restricted metering device	Check superheat and subcooling per chart. Replace.
	X	Defective reversing valve	Perform RV touch test.	
X	X	Thermostat improperly located	Check location and for air drafts behind stat.	
X	X	Unit undersized	Recheck loads & sizing. Check sensible cooling load and heat pump capacity.	
X	X	Scaling in water heat exchanger	Perform scaling check and clean if necessary.	
X	X	Inlet water too hot or cold	Check load, loop sizing, loop backfill, ground moisture.	
High Head Pressure	X		Reduced or no airflow in heating	Check for dirty air filter and clean or replace.
				Check fan motor operation and airflow restrictions.
				Too high of external static? Check static vs. blower table.
		X	Reduced or no water flow in cooling	Check pump operation or valve operation/setting.
				Check water flow. Adjust to proper flow rate.
		X	Inlet water too hot	Check load, loop sizing, loop backfill, ground moisture.
	X		Air temperature out of range in heating	Bring return air temperature within design parameters.
		X	Scaling in water heat exchanger	Perform scaling check and clean if necessary.
	X	X	Unit overcharged	Check superheat and subcooling. Re-weigh in charge.
X	X	Non-condensables in system	Vacuum system and re-weigh in charge.	
X	X	Restricted metering device	Check superheat and subcooling per chart. Replace.	
Low Suction Pressure	X		Reduced water flow in heating	Check pump operation or water valve operation/setting.
				Plugged strainer or filter? Clean or replace.
				Check water flow. Adjust to proper flow rate.
	X		Water temperature out of range	Bring water temperature within design parameters.
		X	Reduced airflow in cooling	Check for dirty air filter and clean or replace.
				Check fan motor operation and airflow restrictions.
			Too high of external static? Check static vs. blower table.	
	X	Air temperature out of range	Too much cold vent air? Bring entering air temperature within design parameters.	
X	X	Insufficient charge	Check for refrigerant leaks.	
Low Discharge Air Temperature in Heating	X		Too high of airflow	Check fan motor speed selection and airflow chart.
	X		Poor performance	See 'Insufficient Capacity'

Table continued on next page.

Models:
SM
006-036

Performance Troubleshooting

Table continued from previous page.

Symptom	Htg	Cig	Possible Cause	Solution
High humidity		X	Too high of airflow	Check fan motor speed selection and airflow chart.
		X	Unit oversized	Recheck loads & sizing. Check sensible cooling load and heat pump capacity.
Only Compressor Runs	X	X	Thermostat wiring	Check G wiring at heat pump. Jumper G and R for fan operation.
	X	X	Fan motor relay	Jumper G and R for fan operation. Check for line voltage across blower relay contacts. Check fan power. Enable relay operation (if present).
	X	X	Fan motor	Check for line voltage at motor. Check capacitor.
	X	X	Thermostat wiring	Check thermostat wiring at CXM2. Put in Test Mode and then jumper Y1 and W1 to R to give call for fan, compressor and electric heat.
Unit Doesn't Operate in Cooling		X	Reversing valve	Set for cooling demand and check 24VAC on RV coil. If RV is stuck, run high pressure up by reducing water flow and, while operating, engage and disengage RV coil voltage to push valve.
		X	Thermostat setup	For DXM2.5, check for "O" RV setup, not "B".
		X	Thermostat wiring	Check O wiring at heat pump. CXM2 requires call for compressor. To get RV coil, "Click".
Modulating Valve Troubleshooting	X	X	Improper output setting	Verify the AO-2 jumper is in the 0-10V position.
	X	X	No valve output signal	Check DC voltage between AO2 and GND. Should be 0 when valve is off and between 3.3V and 10V when valve is on. Check voltage to the valve.
	X	X	No valve operation	Replace valve if voltage and control signals are present at the valve and it does not operate.

Wire Harness for 06-12 (CV) EC with DXM2.5

Models:
SM
006-036

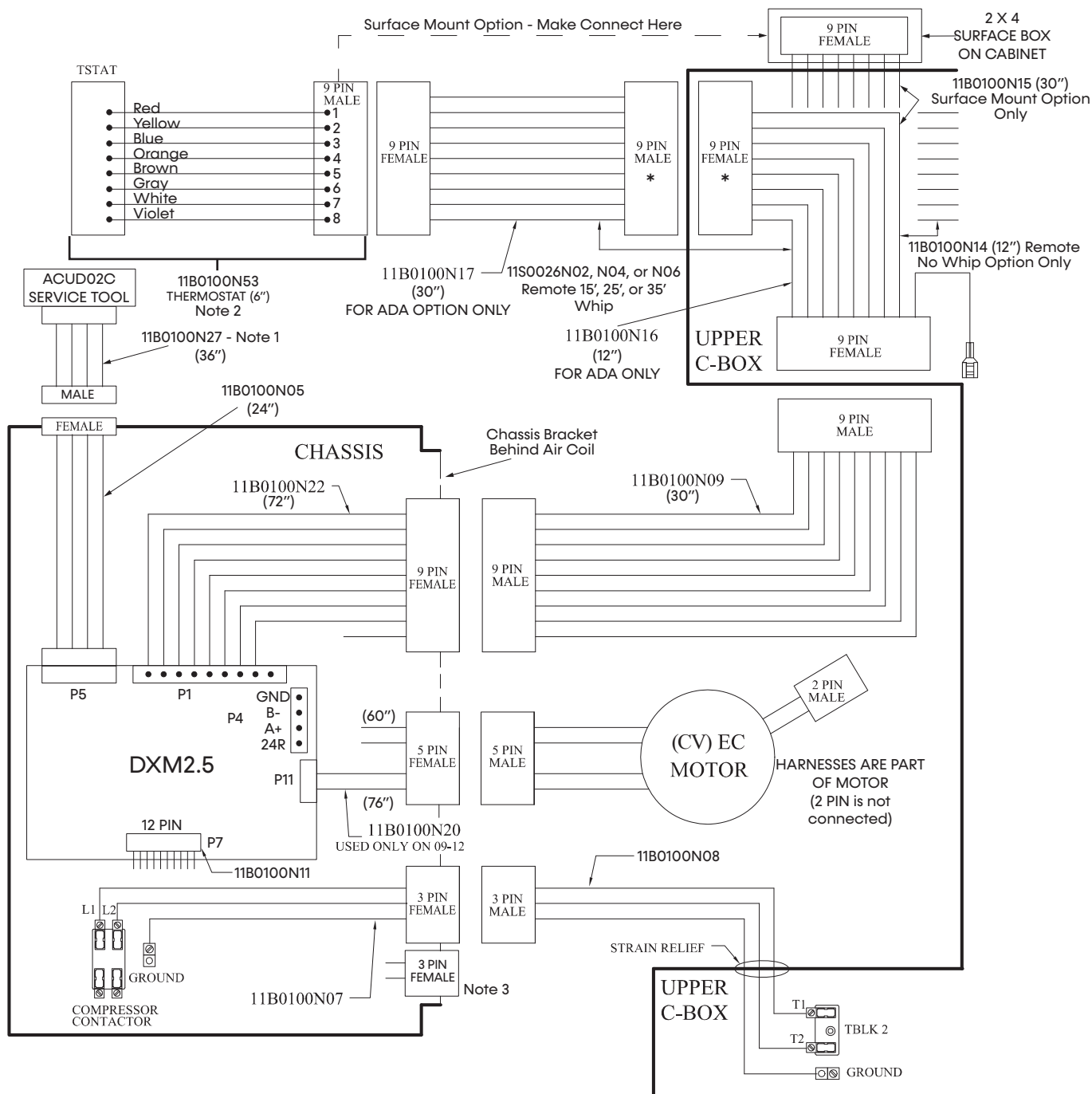

Notes:

1. A quick-connect thermostat harness is provided with optional vertical-stack thermostat kits.
2. For the MPC, you need: 11B0100N56 (in-cabinet, 12-inch), 1B0100N57 (in-chassis, 72-inch), and 11B0100N55 (connects cabinet to chassis, 30-inch).
3. Use the unit wiring diagram for wire colors and connection points.

Use wire harnesses only for part numbers.

Models:
SM
006-036

Wire Harness for 06-12 (CT) EC with DXM2.5

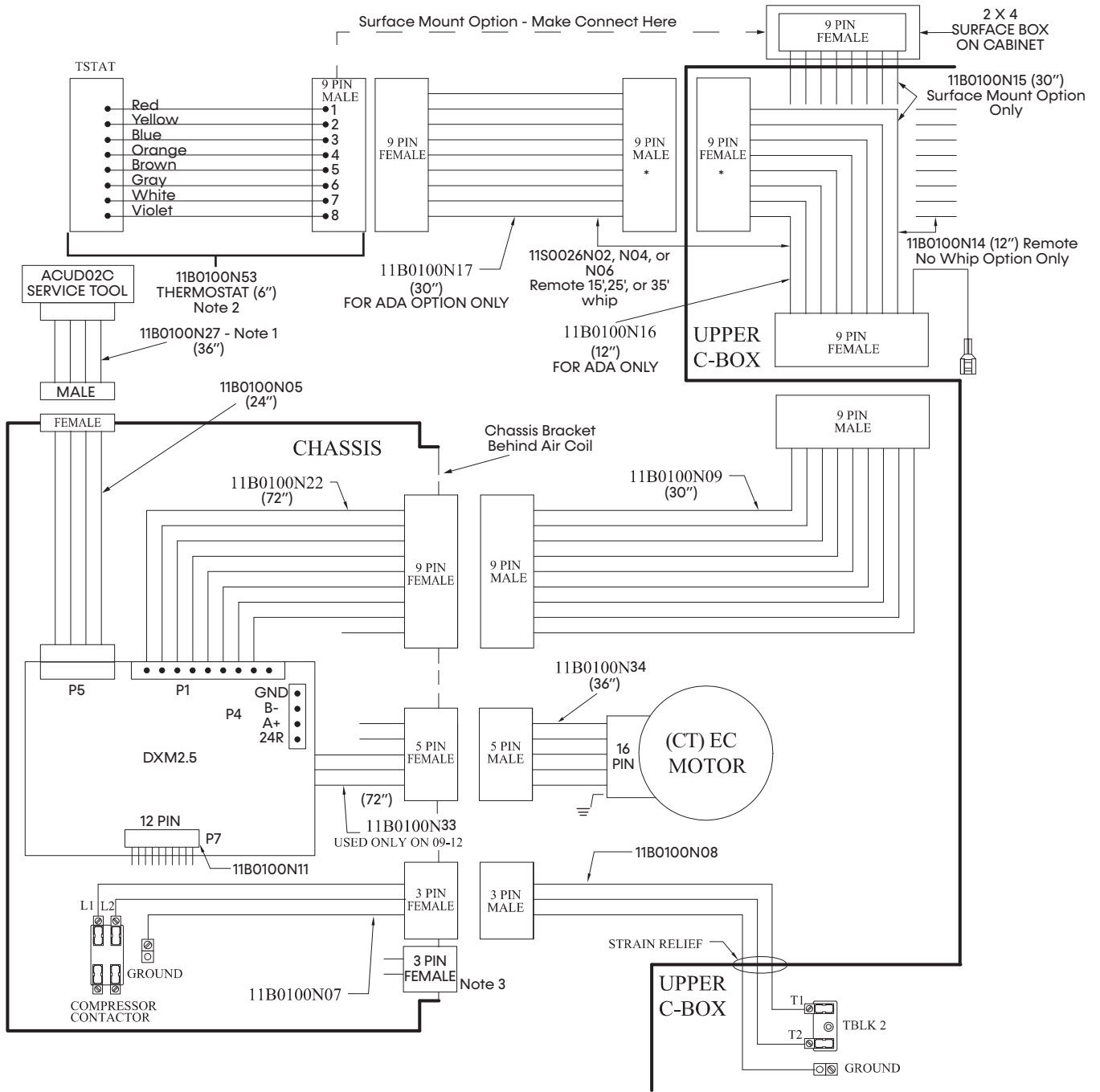

Notes:

1. A quick-connect thermostat harness provided with optional vertical-stack thermostat kits.
2. For the MPC, you need: 11B0100N56 (in-cabinet 12-inch), 11B0100N56 (in-chassis 72-inch), and 11B0100N55 (connects cabinet to chassis, 30-inch).
3. Use the unit wiring diagram for wire colors and connection points.

Use wire harnesses only for part numbers.

Wire Harness for 06-12 (CT) EC with CXM2

Models:
SM
006-036

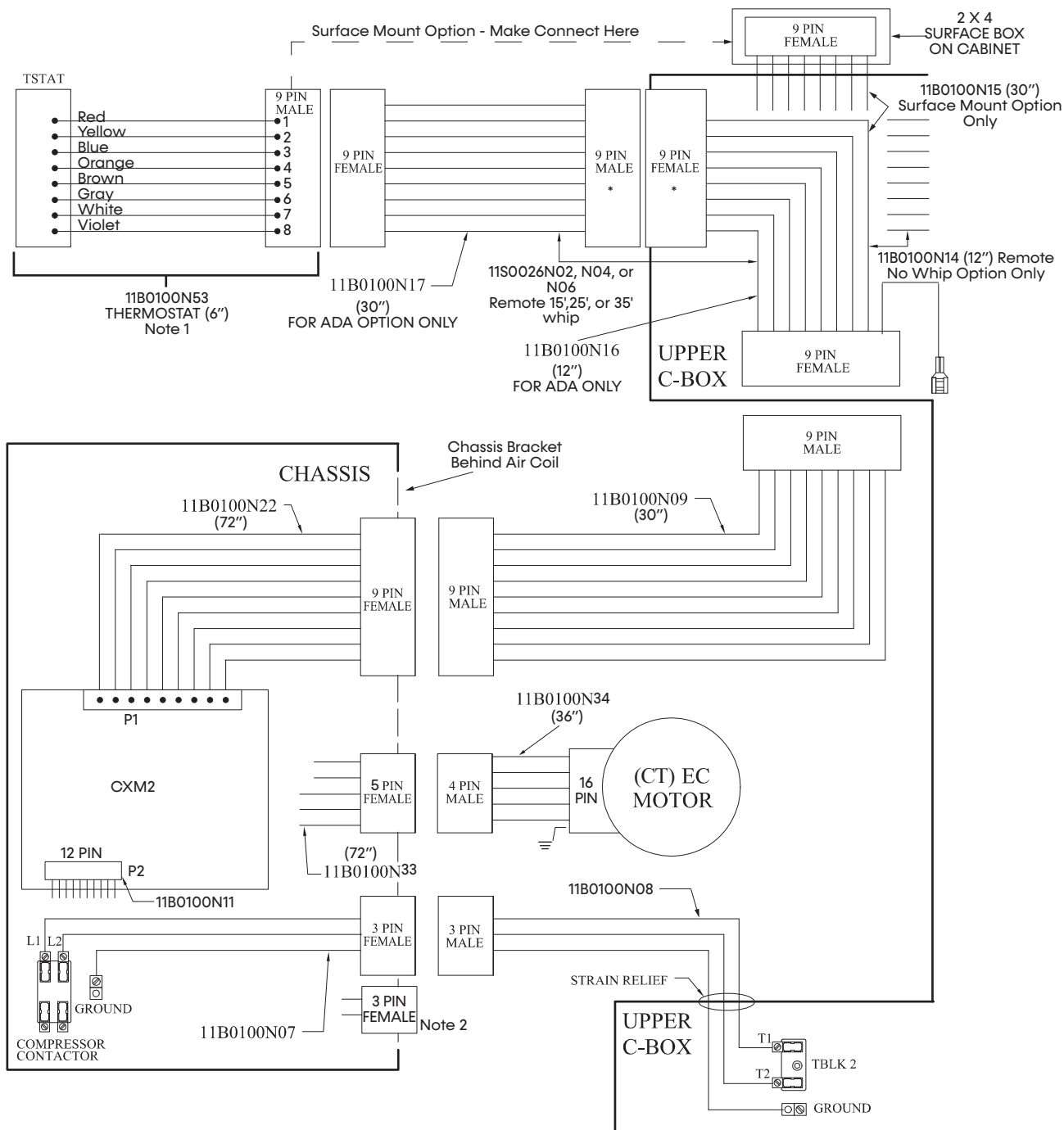

Notes:

1. A quick-connect thermostat harness is provided with optional vertical-stack thermostat kits.
2. For the MPC, you need: 11B0100N56 (in-cabinet, 12-inch), 11B0100N56 (in-chassis, 72-inch), and 11B0100N55 (connects cabinet to chassis, 30-inch).
3. Use the unit wiring diagram for wire colors and connection points.

Use wire harnesses only for part numbers.

Models:
SM
006-036

Wire Harness for 15-36 (CV) EC with DXM2.5

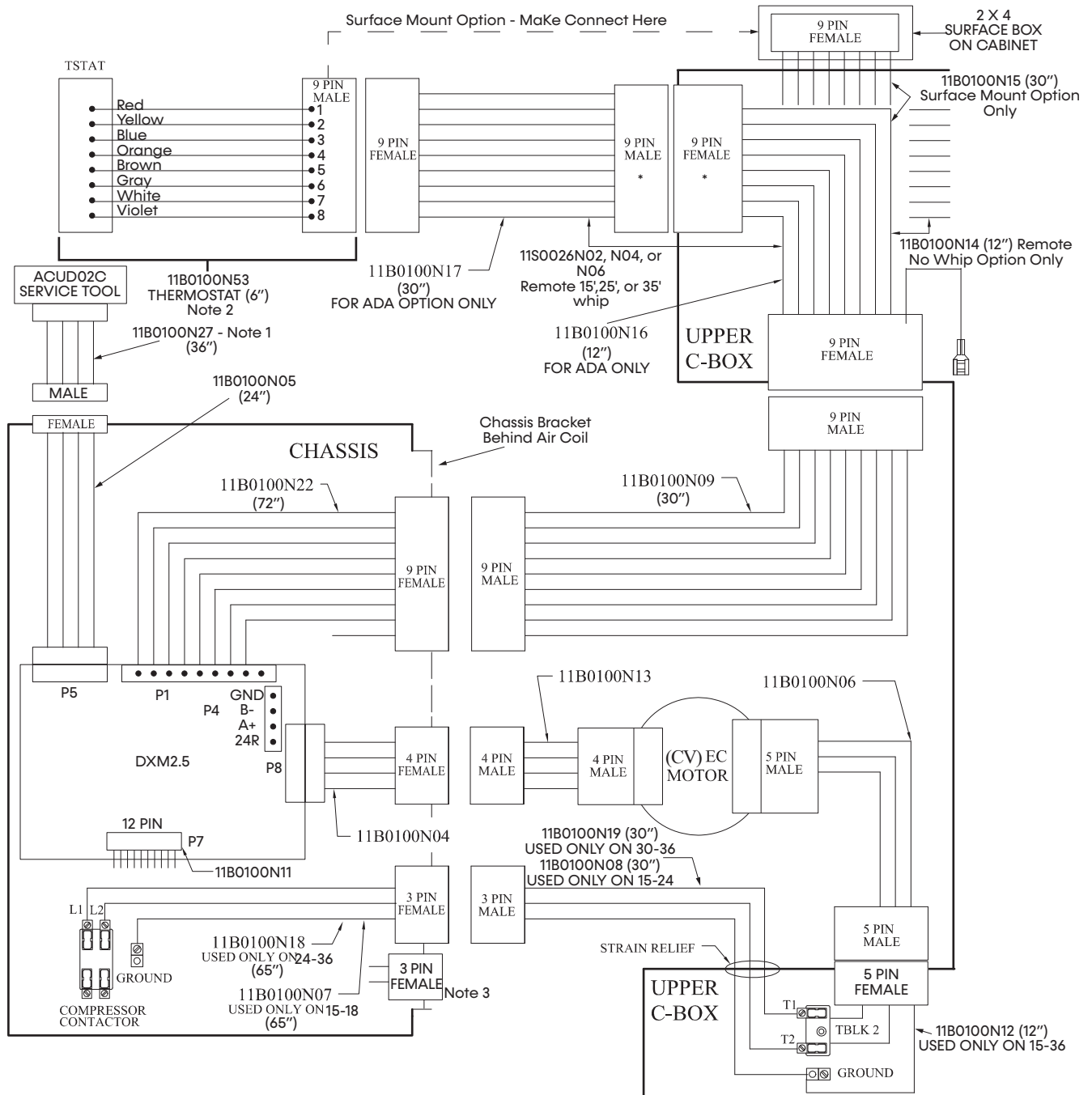

- Notes:
1. A quick-connect thermostat harness is provided with optional vertical-stack thermostat kits.
 2. For the MPC, you need: 11B0100N56 (in-cabinet, 12-inch), 11B0100N56 (in-chassis, 72-inch), and 11B0100N55 (connects cabinet to chassis, 30-inch).
 3. Use the unit wiring diagram for wire colors and connection points.

Use wire harnesses only for part numbers.

Wire Harness for 15-36 (CT) EC with DXM2.5

Models:
SM
006-036

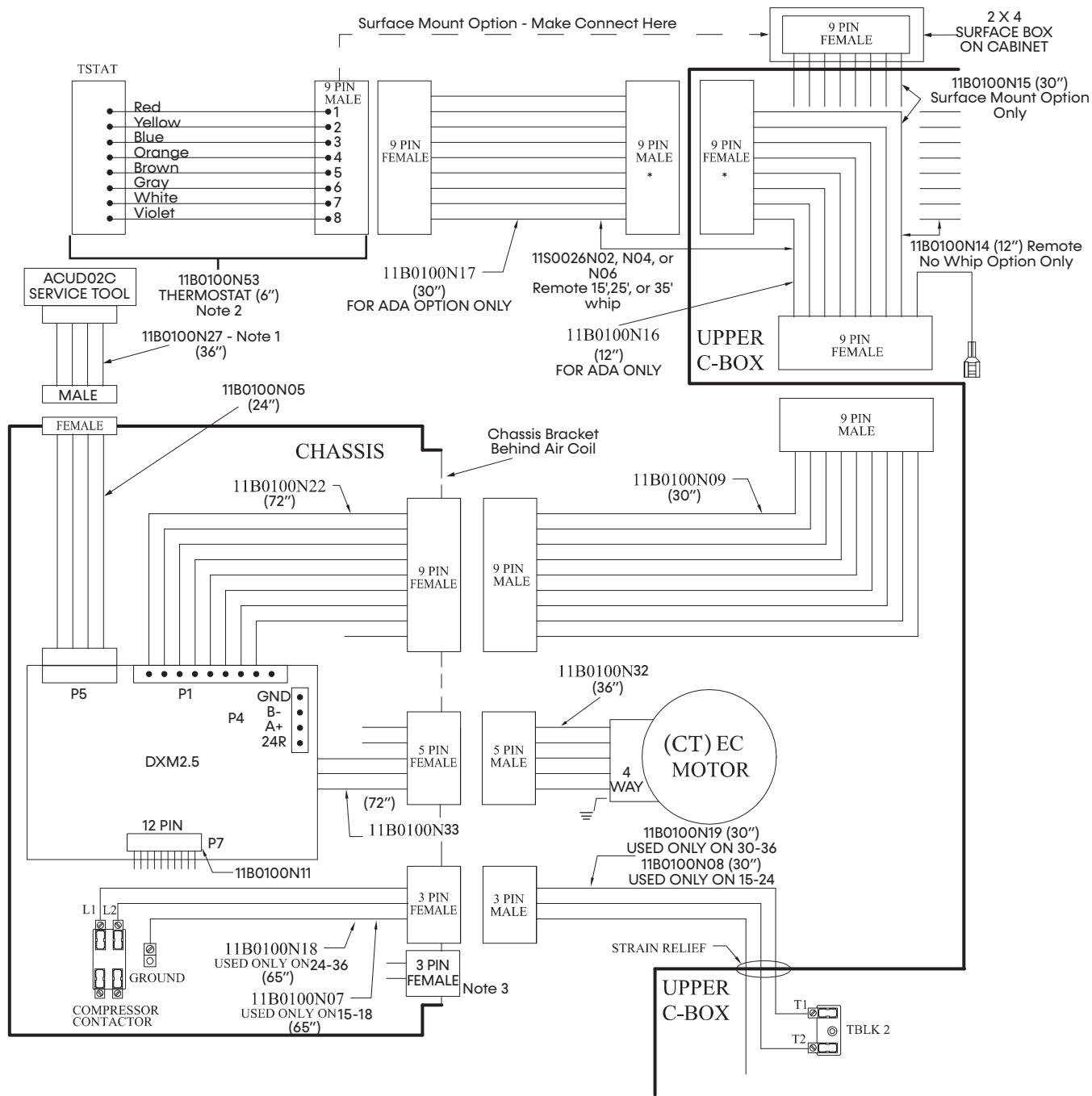

Notes:

1. A quick-connect thermostat harness is provided with optional vertical-stack thermostat kits.
2. For the MPC, you need: 11B0100N56 (in-cabinet, 12-inch), 11B0100N56 (in-chassis, 72-inch), and 11B0100N55 (connects cabinet to chassis, 30-inch).
3. Use the unit wiring diagram for wire colors and connection points.

Use wire harnesses only for part numbers.

Models:
SM
006-036

Wire Harness for 15-36 (CT) EC with CXM2

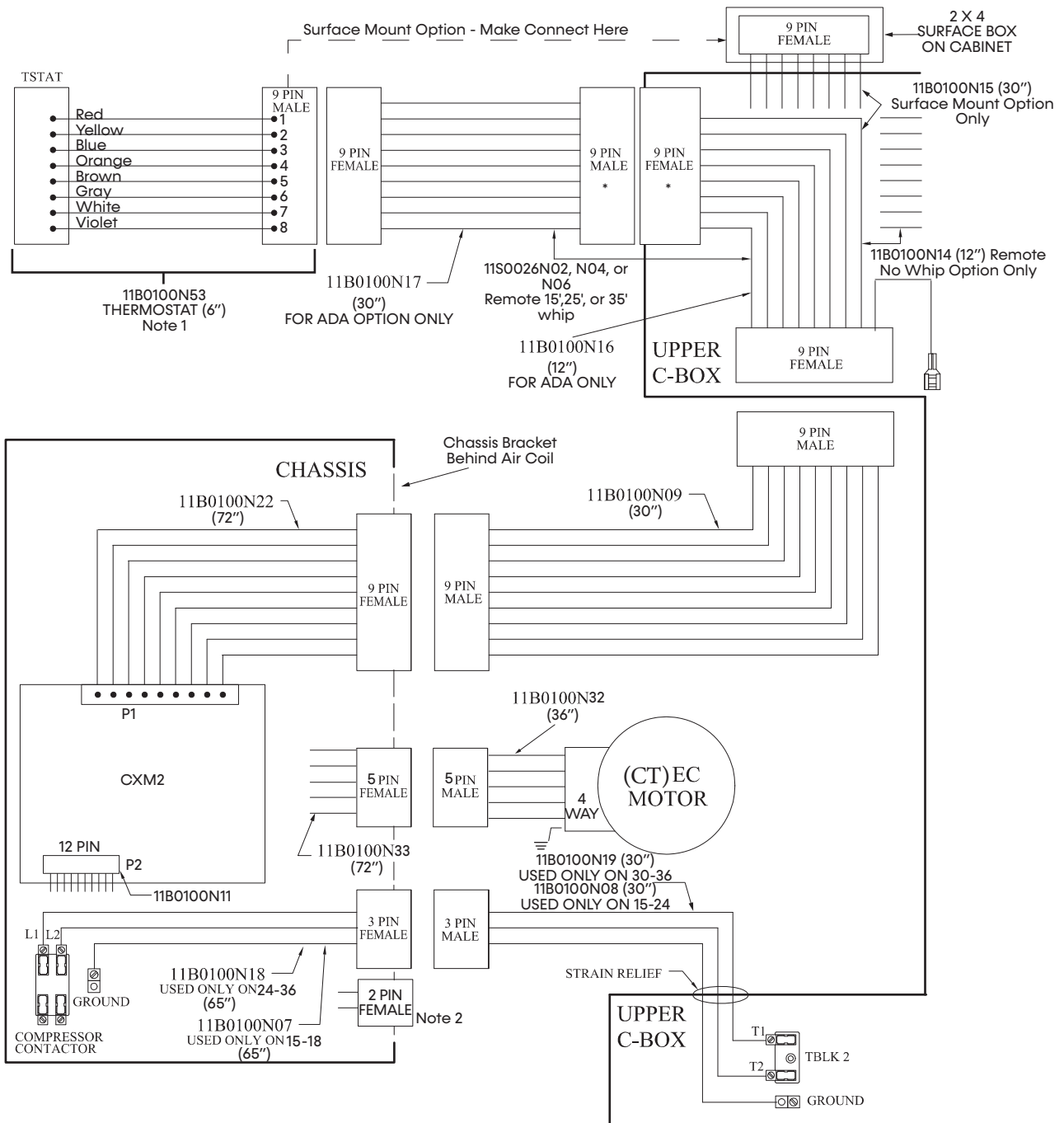

- Notes:
1. A quick-connect thermostat harness is provided with optional vertical-stack thermostat kits.
 2. For the MPC, you need: 11B0100N56 (in-cabinet, 12-inch), 11B0100N56 (in-chassis, 72-inch), and 11B0100N55 (connects cabinet to chassis, 30-inch).
 3. Use the unit wiring diagram for wire colors and connection points.

Use wire harnesses only for part numbers.

Troubleshooting Form

Water-to-Air Units

Customer: _____ Loop Type: _____ Startup Date: _____

Model #: _____ Serial #: _____ Antifreeze Type & %: _____

Complaint: _____

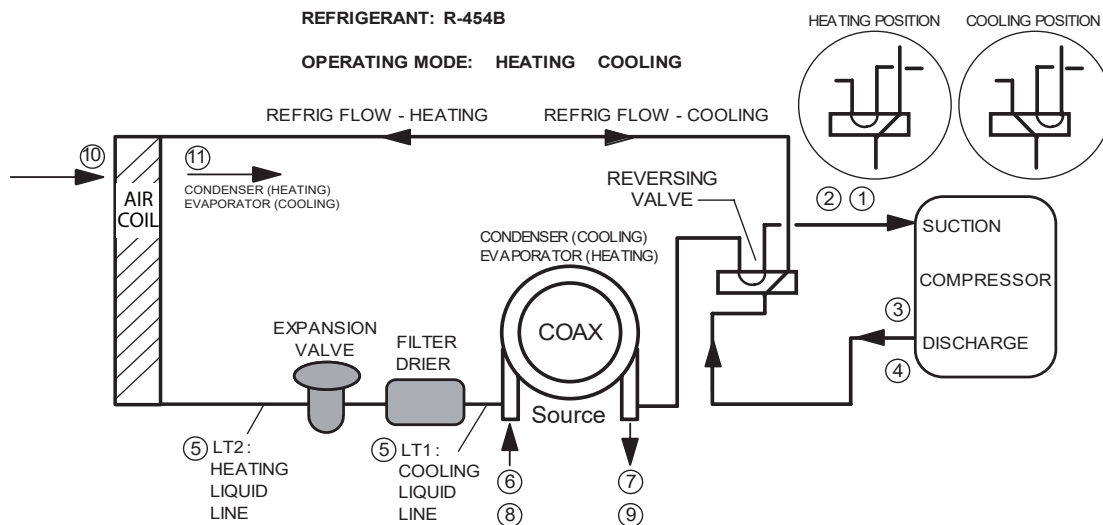

Description	Heating	Cooling	Notes
Voltage			
Compressor Amps			
1 Suction Temp			
2 Suction Press			
2a Saturation Temp			
2b Superheat			
3 Discharge Temp			
4 Discharge Press			
4a Saturation Temp			
4b Subcooling			
5 Liquid Line Temp			
6 Source Water In Tmp			
7 Source Water Out Tmp			Temp Diff. =
8 Source Water In Pres			
9 Source Water Out Pres			
9a Press Drop			
9b Flow Rate			
10 Return Air Temp			
11 Supply Air Temp			

Heat of Extraction (Absorption) or Heat of Rejection:

Fluid Factor: (for Btuh)
500 (Water); 485 (Antifreeze)

Fluid Factor: (for kW)
4.18 (Water); 4.05 (Antifreeze)

HE or HR =

_____ Flow Rate x _____ Temp. Diff x _____ Fluid Factor

Superheat = Suction temperature - suction saturation temp. = _____ (deg F)

Subcooling = Discharge saturation temp. - liquid line temp. = _____ (deg F)

Models:
SM
006-036

Warranty

CLIMATE MASTER, INC. LIMITED EXPRESS WARRANTY/ LIMITATION OF REMEDIES AND LIABILITY



It is expressly understood that unless a statement is specifically identified as a warranty, statements made by Climate Master, Inc., a Delaware corporation, ("CM") or its representatives, relating to CM's products, whether oral, written or contained in any sales literature, catalog or any other agreement, are not express warranties and do not form a part of the basis of the bargain, but are merely CM's opinion or commendation of CM's products. **EXCEPT AS SPECIFICALLY SET FORTH HEREIN, THERE IS NO EXPRESS WARRANTY AS TO ANY OF CM'S PRODUCTS. CM MAKES NO WARRANTY AGAINST LATENT DEFECTS. CM MAKES NO WARRANTY OF MERCHANTABILITY OF THE GOODS OR OF THE FITNESS OF THE GOODS FOR ANY PARTICULAR PURPOSE.**

GRANT OF LIMITED EXPRESS WARRANTY
CM warrants CM products purchased and retained in the United States of America and Canada to be free from defects in material and workmanship under normal use and maintenance as follows: (1) All complete air conditioning, heating and/or heat pump units built or sold by CM for twelve (12) months from date of unit start up or eighteen (18) months from date of shipment (from factory), whichever comes first; (2) Repair and replacement parts, which are not supplied under warranty, for ninety (90) days from date of shipment (from factory). All parts must be returned to CM's factory in Oklahoma City, Oklahoma, freight prepaid, no later than sixty (60) days after the date of the failure of the part; if CM determines the part to be defective and within CM's Limited Express Warranty, CM shall, when such part has been either replaced or repaired, return such to a factory recognized dealer, contractor or service organization, F.O.B., CM's factory, Oklahoma City, Oklahoma, freight prepaid. The warranty on any parts repaired or replaced under warranty expires at the end of the original warranty period.

This warranty does not cover and does not apply to: (1) Air filters, fuses, refrigerant, fluids, oil; (2) Products relocated after initial installation; (3) Any portion or component of any system that is not supplied by CM, regardless of the cause of the failure of such portion or component; (4) Products on which the unit identification tags or labels have been removed or defaced; (5) Products on which payment to CM is or has been in default; (6) Products which have defects or damage which result from improper installation, wiring, electrical imbalance characteristics or maintenance; or are caused by accident, misuse or abuse, fire, flood, alteration or misapplication of the product; (7) Products which have defects or damage which result from a contaminated or corrosive air or liquid supply, operation at abnormal temperatures, or unauthorized opening of refrigerant circuit; (8) Mold, fungus or bacteria damages; (9) Products subjected to corrosion or abrasion; (10) Products manufactured or supplied by others; (11) Products which have been subjected to misuse, negligence or accidents; (12) Products which have been operated in a manner contrary to CM's printed instructions; or (13) Products which have defects, damage or insufficient performance as a result of insufficient or incorrect system design or the improper application of CM's products.

CM is not responsible for: (1) The costs of any fluids, refrigerant or other system components, or associated labor to repair or replace the same, which is incurred as a result of a defective part covered by CM's Limited Express Warranty; (2) The costs of labor, refrigerant materials or service incurred in removal of the defective part, or in obtaining and replacing the new or repaired part; (3) Transportation costs of the defective part from the installation site to CM or of the return of any part not covered by CM's Limited Express Warranty.

Limitation: This Limited Express Warranty is given in lieu of all other warranties. If, notwithstanding the disclaimers contained herein, it is determined that other warranties exist, any such warranties, including without limitation any express warranties or any implied warranties of fitness for particular purpose and merchantability, shall be limited to the duration of the Limited Express Warranty.

LIMITATION OF REMEDIES
In the event of a breach of the Limited Express Warranty, CM will only be obligated at CM's option to repair the failed part or unit or to furnish a new or rebuilt part or unit in exchange for the part or unit which has failed. If after written notice to CM's factory in Oklahoma City, Oklahoma of each defect, malfunction or other failure and a reasonable number of attempts by CM to correct the defect, malfunction or other failure and the remedy fails of its essential purpose, CM shall refund the purchase price paid to CM in exchange for the return of the sold goods. Said refund shall be the maximum liability of CM. **THIS REMEDY IS THE SOLE AND EXCLUSIVE REMEDY OF THE BUYER OR THEIR PURCHASER AGAINST CM FOR BREACH OF CONTRACT, FOR THE BREACH OF ANY WARRANTY OR FOR CM'S NEGLIGENCE OR IN STRICT LIABILITY.**

LIMITATION OF LIABILITY
CM shall have no liability for any damages if CM's performance is delayed for any reason or is prevented to any extent by any event such as, but not limited to, any war, civil unrest, government restrictions or restraints, strikes or work stoppages, fire, flood, accident, shortages of transportation fuel, material, or labor acts of God or any other reason beyond the sole control of CM. **CM EXPRESSLY DISCLAIMS AND EXCLUDES ANY LIABILITY FOR CONSEQUENTIAL OR INCIDENTAL DAMAGE IN CONTRACT, FOR BREACH OF ANY EXPRESS OR IMPLIED WARRANTY, OR IN TORT, WHETHER FOR CM'S NEGLIGENCE OR AS STRICT LIABILITY.**

OBTAINING WARRANTY PERFORMANCE
Normally, the contractor or service organization who installed the products will provide warranty performance for the owner. Should the installer be unavailable, contact any CM recognized dealer, contractor or service organization. If assistance is required in obtaining warranty performance, write or call:

Climate Master, Inc. • Customer Service • 7300 S. W. 44th Street • Oklahoma City, Oklahoma 73179 (405) 745-6000

NOTE: Some states or Canadian provinces do not allow limitations on how long an implied warranty lasts, or the limitation or exclusions of consequential or incidental damages, so the foregoing exclusions and limitations may not apply to you. This warranty gives you specific legal rights, and you may also have other rights which vary from state to state and from Canadian province to Canadian province.

Please refer to the CM Installation, Operation and Maintenance Manual for operating and maintenance instructions.



Rev: 11/09

Notes

Models:
SM
006-036

Models:
SM
006-036

Revision History

Date	Section	Description
03/06/2024	All	Created



A NIBE GROUP MEMBER

7300 SW 44th St. | Oklahoma City, OK 73179
Phone: 1-800-299-9747
www.climatemaster.com



ClimateMaster works continually to improve its products. As a result, the design and specifications of each product at the time of order may be changed without notice and may not be as described herein. Please contact ClimateMaster's Customer Service Department at 1-800-299-9747 for specific information on the current design and specifications. Statements and other information contained herein are not express warranties and do not form the basis of any bargain between the parties, but are merely ClimateMaster's opinion or commendation of its products. The latest version of this document is available at www.climatemaster.com.

Engineered and assembled in the USA.

© ClimateMaster, Inc. All Rights Reserved 2024