



TRANQUILITY® 24 (SZ) VERSATILE TWO-STAGE SERIES **INSTALLATION, OPERATION & MAINTENANCE MANUAL**

Part#: 97B0075N35 | Updated: April 8, 2024

Models: SZ 024-060
60Hz - R-454B



Models:
SZ
024-060

Table of Contents

3	Model Nomenclature	40	Electrical: DXM2.5 Example Wiring Diagram
4	Attentions, Cautions, and Warnings	41	Electrical: Low-Voltage Wiring
6	General Information	45	Electrical: Thermostat Wiring
9	Minimum Installation Area	46	Blower Performance Data
11	Refrigerant System Servicing	47	Controls: DXM2.5
13	Physical Data	48	Operating and Commissioning Limits
14	Horizontal Installation	49	Piping System Cleaning and Flushing
15	Horizontal Installation: Service Access	50	Unit System Checkout
18	Duct System Installation	51	Unit Startup Procedure
19	Field Conversion of Air Discharge	53	Unit Operating Conditions
20	Vertical Installation	57	Preventative Maintenance
22	Vertical Installation: Service Access	58	Troubleshooting
23	Piping Installation	60	DXM2.5 Functional Troubleshooting Flow Chart
24	vFlow Heat Pump Applications Overview	61	Functional Troubleshooting
27	Water-Loop Heat Pump Applications	64	Performance Troubleshooting
28	Ground-Loop Heat Pump Applications	66	Startup Log Sheet
30	Ground-Water Heat Pump Applications	67	Functional Troubleshooting Form
32	Water Quality Requirements	68	Warranty (U.S. and Canada)
36	Electrical Data: CV EC Blower Motor Standard Unit	69	Warranty (International)
39	Electrical: Power Wiring	72	Revision History

ClimateMaster works continually to improve its products. As a result, the design and specifications of each product at the time of order may be changed without notice and may not be as described herein. Please contact ClimateMaster's Customer Service Department at (405) 815-3000 for specific information on the current design and specifications. Statements and other information contained herein are not express warranties and do not form the basis of any bargain between the parties, but are merely ClimateMaster's opinion or commendation of its products.

Model Nomenclature

1 | 2 | 3 | 4 | 5 | 6 | 7 | 8 | 9 | 10 | 11 | 12 | 13 | 14 | 15
S | **Z** | **L** | **0** | **2** | **4** | **A** | **G** | **D** | **3** | **0** | **C** | **0** | **V** | **S**

MODEL

S = R-454B Refrigerant

MODEL TYPE

Z = Versatile Two-Stage Series

SUPPLY & RETURN CONFIGURATIONS

Horizontal Configuration		
	Left	Right
Straight	L	R
Back	B	P

Vertical Configuration		
	Left	Right
Top	T	K

SIZE

024 042
 030 048
 036 060

REVISION

A = Current

VOLTAGE

G = 208/230-1-60 J = 208/230-1-60 Refrigerant Detection System
 H = 208/230-1-60 K = 208/230-3-60 Refrigerant Detection System
 F = 460-3-60 L = 460-3-60 Refrigerant Detection System

CONTROLS

Control	Standard	MPC
DXM2.5	D	P
DXM2.5 with Disconnect	B	S

CABINET

Cabinet	UltraQuiet	Rail		Frame	
		1"	2"	1"	2"
Extended Range	No	1	J	K	A
	Yes	2	L	M	C
Standard Range	No	3	N	P	E
	Yes	4	F	S	G

STANDARD

S = Standard

BLOWER MOTOR

V = Constant Volume (CV) EC

EXTENDED OPTIONS

O = Standard
 G = HWG
 P = HWG and Pump

DRAIN PAN/HEAT EXCHANGER OPTIONS

C = Standard Drain Pan, Non-Coated Air Coil
 T = Standard Drain Pan, Tin-Coated Air Coil
 S = Stainless Steel Drain Pan, Non-Coated Air Coil
 R = Stainless Steel Drain Pan, Tin-Coated Air Coil

WATER/HEAT EXCHANGER OPTIONS

Water Option	Standard	Cupro Nickel
None	0	Z
MOD Valve	C	N
Internal Pump Standard Head (Variable with Check Valve)	3	-
Internal Pump Standard Head (Variable without Check Valve)	J	
Internal Pump High Head (Variable with Check Valve)	4	
Internal Pump High Head (Variable without Check Valve)	K	
ISP	7	

Use ClimateMaster's selection software at <https://climatemastersolutions.com/eRep/> to configure your Tranquility SZ model.

Models:
SZ
024-060

Attentions, Cautions, and Warnings

SAFETY

Warnings, cautions, and notices appear throughout this manual. Read these items carefully before attempting any installation, service, or troubleshooting of the equipment.

DANGER: Indicates an immediate hazardous situation, which if not avoided will result in death or serious injury. DANGER labels on unit access panels must be observed.

WARNING: Indicates a potentially hazardous situation, which if not avoided could result in death or serious injury.

CAUTION: Indicates a potentially hazardous situation or an unsafe practice, which if not avoided could result in minor or moderate injury or product or property damage.

NOTICE: Notification of installation, operation, or maintenance information, which is important, but which is not hazard-related.

WARNING



Disconnect power supply(ies) before servicing. Refer servicing to qualified service personnel. Electric shock hazard. May result in injury or death!

WARNING

To avoid the release of refrigerant into the atmosphere, the refrigerant circuit of this unit must be serviced only by technicians who meet local, state, and federal proficiency requirements.

WARNING

The installation of water-source heat pumps and all associated components, parts, and accessories which make up the installation shall be in accordance with the regulations of ALL authorities having jurisdiction and MUST conform to all applicable codes. It is the responsibility of the installing contractor to determine and comply with ALL applicable codes and regulations.

WARNING

The appliance shall be stored in a room without continuously operating ignition sources (for example: open flames, an operating gas appliance or an operating electric heater).

WARNING

If unit connected via an air duct system to one or more rooms with R-454B is installed in a room with an area less than A_{min} or has an Effective Dispersal Volume less than minimum, that room shall be without continuously operating open flames or other POTENTIAL IGNITION SOURCES. A flame-producing device may be installed in the same space if the device is provided with an effective flame arrest.

WARNING

All refrigerant discharged from this unit must be recovered WITHOUT EXCEPTION. Technicians must follow industry accepted guidelines and all local, state, and federal statutes for the recovery and disposal of refrigerants. If a compressor is removed from this unit, refrigerant circuit oil will remain in the compressor. To avoid leakage of compressor oil, refrigerant lines of the compressor must be sealed after it is removed.

WARNING

This appliance is not intended for use by persons (including children) with reduced physical, sensory, or mental capabilities, or lack of experience and knowledge, unless they have been given supervision or instruction concerning use of the appliance by a person responsible for their safety.

WARNING

An unventilated area where the appliance using FLAMMABLE REFRIGERANTS is installed shall be so constructed that should any refrigerant leak, it will not stagnate so as to create a fire or explosion hazard.

WARNING

Auxiliary devices which may be a POTENTIAL IGNITION SOURCE shall not be installed in the duct work. Examples of such POTENTIAL IGNITION SOURCES are hot surfaces with a temperature exceeding 1,292°F (700°C)

WARNING

An unventilated area where a water source heat pump is installed and surpasses a R-454B refrigerant charge of 62 oz (1.76 kg), shall be without continuously operating open flames (for example an operating gas appliance) or other POTENTIAL IGNITION SOURCES (for example, an operating electric heater, hot surfaces).

WARNING

Only auxiliary electric heaters approved by ClimateMaster shall be installed in connecting ductwork. The installation of any other auxiliary devices is beyond ClimateMaster's responsibility.

WARNING

For mechanical ventilation, the lower edge of the air extraction opening where air is exhausted from the room shall not be more than 3.94 inches (100 mm) above the floor. The location where the mechanical ventilation air extracted from the space is discharged shall be separated by a sufficient distance, but not less than 9.84 feet (3 m), from mechanical ventilation air intake openings, to prevent recirculation to the space.

WARNING

Children being supervised are NOT to play with the appliance.

WARNING

Do not pierce or burn.

WARNING

Be aware that refrigerants may not contain odor.

Attentions, Cautions, and Warnings

CAUTION

DO NOT store or install units in corrosive environments or in locations subject to temperature or humidity extremes (e.g., attics, garages, rooftops, etc.). Corrosive conditions and high temperature or humidity can significantly reduce performance, reliability, and service life. Always move and store units in an upright position. Tilting units on their sides will cause equipment damage.

CAUTION

CUT HAZARD - Failure to follow this caution may result in personal injury. Sheet metal parts may have sharp edges or burrs. Use care and wear appropriate protective clothing, safety glasses and gloves when handling parts and servicing heat pumps.

CAUTION

To avoid equipment damage, DO NOT use these units as a source of heating or cooling during the construction process. The mechanical components and filters can quickly become clogged with construction dirt and debris, which may cause system damage and void product warranty.

CAUTION

All three phase scroll compressors must have direction of rotation verified at startup. Verification is achieved by checking compressor Amp draw. Amp draw will be substantially lower compared to nameplate values. Additionally, reverse rotation results in an elevated sound level compared to correct rotation. Reverse rotation will result in compressor internal overload trip within several minutes. Verify compressor type before proceeding.

NOTICE

Servicing shall be performed only as recommended by the manufacturer.

NOTICE

REFRIGERANT SENSORS for REFRIGERANT DETECTION SYSTEMS shall only be replaced with sensors specified by the appliance manufacturer.

Models:
SZ
024-060

General Information

INSPECTION

Upon receipt of the equipment, carefully check the shipment against the bill of lading. Make sure all units have been received. Inspect the packaging of each unit, and inspect each unit for damage. Ensure that the carrier makes proper notation of any shortages or damage on all copies of the freight bill and completes a common carrier inspection report. Concealed damage not discovered during unloading must be reported to the carrier within 15 days of receipt of shipment. If not filed within 15 days, the freight company can deny the claim without recourse.

NOTE: It is the responsibility of the purchaser to file all necessary claims with the carrier. Notify your equipment supplier of all damage within 15 days of shipment.

STORAGE

Equipment should be stored in its original packaging in a clean, dry area. Store units in an upright position at all times. You may stack vertical configurations a maximum of two units high and horizontal configurations a maximum of three units high.

UNIT PROTECTION

Cover units on the job site with either the original packaging or an equivalent protective covering. Cap the open ends of pipes stored on the job site. In areas where painting, plastering, and/or spraying has not been completed, all due precautions must be taken to avoid physical damage to the units and contamination by foreign material. Physical damage and contamination may prevent proper startup and may result in costly equipment cleanup.

Examine all pipes, fittings, and valves before installing any of the system components. Remove any dirt or debris found in or on these components.

PRE-INSTALLATION

Installation, Operation, and Maintenance instructions are provided with each unit. Horizontal equipment is designed for installation above false ceiling or in a ceiling plenum. Other unit configurations are typically installed in a mechanical room. The installation site chosen should include adequate service clearance around the unit. Before unit startup, read all manuals and become familiar with the unit and its operation. Thoroughly check the system before operation.

PREPARE UNITS FOR INSTALLATION AS FOLLOWS:

1. Compare the electrical data on the unit nameplate with ordering and shipping information to verify that the correct unit has been shipped.
2. Keep the cabinet covered with the original packaging until installation is complete and all plastering, painting, etc. is finished.
3. Verify refrigerant tubing is free of kinks or dents and that it does not touch other unit components.
4. Inspect all electrical connections. Connections must be clean and tight at the terminals.
5. Remove any blower support packaging (water-to-air units only).
6. Some airflow patterns are field convertible (horizontal units only). Locate the airflow conversion section of this IOM.
7. Locate and verify any hot water generator (HWG), hanger, or other accessory kit located in the compressor section or blower section.

CHECKS TO THE AREA

Prior to beginning work on systems containing FLAMMABLE REFRIGERANTS, safety checks are necessary to ensure that the risk of ignition is minimized. For repair to the REFRIGERATING SYSTEM, these steps shall be completed prior to conducting work on the system.

General Information

Work Procedure

Work shall be undertaken under a controlled procedure so as to minimise the risk of a flammable gas or vapor being present while the work is being performed.

General Work Area

All maintenance staff and others working in the local area shall be instructed on the nature of work being carried out. Work in confined spaces shall be avoided.

Checking for presence of refrigerant

The area shall be checked with an appropriate refrigerant detector prior to and during work, to ensure the technician is aware of potentially toxic or flammable atmospheres. Ensure that the leak detection equipment being used is suitable for use with all applicable refrigerants, i.e. non-sparking, adequately sealed or intrinsically safe.

Presence of fire Extinguisher

If any hot work is to be conducted on the refrigeration equipment or any associated parts, appropriate fire extinguishing equipment shall be available to hand. Have a dry powder or CO₂ fire extinguisher adjacent to the charging area.

No ignition sources

No person carrying out work in relation to a REFRIGERATION SYSTEM which involves exposing any pipe work shall use any sources of ignition in such a manner that it may lead to the risk of fire or explosion. All possible ignition sources, including cigarette smoking, should be kept sufficiently far away from the site of installation, repairing, removing and disposal, during which refrigerant can possibly be released to the surrounding space. Prior to work taking place, the area around the equipment is to be surveyed to make sure that there are no flammable hazards or ignition risks. "No Smoking" signs shall be displayed.

Ventilated area

Ensure that the area is in the open or that it is adequately ventilated before breaking into the system or conducting any hot work. A degree of ventilation shall continue during the period that the work is carried out. The ventilation should safely disperse any released refrigerant and preferably expel it externally into the atmosphere.

Checks to the Refrigeration Equipment

The following checks shall be applied to installations using FLAMMABLE REFRIGERANTS:

- The actual REFRIGERANT CHARGE is in accordance with the room size within which the refrigerant containing parts are installed;
- The ventilation machinery and outlets are operating adequately and are not obstructed;
- If an indirect refrigerating circuit is being used, the secondary circuit shall be checked for the presence of refrigerant;
- Marking to the equipment continues to be visible and legible. Markings and signs that are illegible shall be corrected;
- Refrigerant piping or components are installed in a position where they are unlikely to be exposed to any substance which may corrode refrigerant containing components, unless the components are constructed of materials which are inherently resistant to being corroded or are suitably protected against being so corroded.

Checks to Electrical Devices

Repair and maintenance to electrical components shall include initial safety checks and component inspection procedures. If a fault exists that could compromise safety, then no electrical supply shall be connected to the circuit until it is satisfactorily dealt with. If the fault cannot be corrected immediately but it is necessary to continue operation, an adequate temporary solution shall be used. This shall be reported to the owner of the equipment so all parties are advised.

Initial safety checks shall include:

- Capacitors are discharged: this shall be done in a safe manner to avoid possibility of sparking;
- That no live electrical components and wiring are exposed while charging, recovering, or purging the system;
- That there is continuity of earth bonding.

Models:
SZ
024-060

General Information

REPAIR TO INTRINSICALLY SAFE COMPONENTS

Intrinsically safe components must be replaced.

CABLING

Check that cabling will not be subject to wear, corrosion, excessive pressure, vibration, sharp edges or any other adverse environmental effects. The check shall also take into account the effects of aging or continual vibration from sources such as compressors or fans.

REQUIRED AREA FOR INSTALLATION

The minimum room area of the space (A_{min}) or a minimum room area of conditioned space (T_{amin}) shall be corrected for unit's location altitude by multiplying A_{min} or T_{amin} by the applicable altitude adjustment factor (AF) for building ground-level altitude (H_{alt}) in feet or meters, as shown in Table 1.

Note: You can use Imperial or Metric measurements to calculate A_{min} or T_{amin} .

Table 1: Altitude Adjustment

H_{alt} ft (m)	AF
0 (0)	1.00
656 (200)	1.00
1,312 (400)	1.00
1,968 (600)	1.00
2,624 (800)	1.02
3,280 (1,000)	1.05
3,937 (1,200)	1.07
4,593 (1,400)	1.10
5,249 (1,600)	1.12
5,905 (1,800)	1.15
6,561 (2,000)	1.18
7,217 (2,200)	1.21
7,874 (2,400)	1.25
8,530 (2,600)	1.28
9,186 (2,800)	1.32
9,842 (3,000)	1.36
10,498 (3,200)	1.40

Minimum Installation Area

MINIMUM INSTALLATION AREA

Minimum area where a blower-equipped unit must be installed, and mechanical/natural ventilation is not required

Model	Charge (oz)	Configuration	Minimum Installation Area ft ² (m ²) [A _{min}]			
			Floor	Window	Wall	Ceiling
SZ060	69	Vertical	261 (80)	92 (28)	61 (19)	52 (16)
		Horizontal	5,601 (1,707)	139 (42)	78 (24)	64 (20)

A_{min} = Minimum area where unit is installed where unit has incorporated airflow

h_{inst} (floor) = 0.0 ft (0.0 m)

h_{inst} (window) = 3.3 ft (1.0 m)

h_{inst} (wall) = 5.9 ft (1.8 m)

h_{inst} (ceiling) = 7.2 ft (2.2 m)

Minimum CFM of a unit that requires a blower for mitigation mode

Model	Charge (oz)	Configuration	Minimum CFM [Q _{min}]
SZ060	69	Vertical	394
		Horizontal	339

Q_{min} = Minimum CFM provided by unit

Minimum area where the exhausted air is being sent if mechanical ventilation is used

Model	Charge (oz)	Configuration	Minimum Exhaust Area ft ² (m ²) [A _{min}]			
			Floor	Window	Wall	Ceiling
SZ060	69	Vertical	127 (38)	122 (37)	118 (36)	116 (35)
		Horizontal	129 (39)	118 (36)	109 (33)	104 (31)

EA_{min} = Minimum area where the exhausted air is sent

h_{inst} (floor) = 0.0 ft (0.0 m)

h_{inst} (window) = 3.3 ft (1.0 m)

h_{inst} (wall) = 5.9 ft (1.8 m)

h_{inst} (ceiling) = 7.2 ft (2.2 m)

Minimum CFM for mechanical ventilation

Model	Charge (oz)	Configuration	Minimum CFM [Q _{min}]			
			Floor	Window	Wall	Ceiling
SZ060	69	Vertical	114	110	106	104
		Horizontal	116	106	98	94

Q_{min} = Minimum area where the exhausted air is sent

h_{inst} (floor) = 0.0 ft (0.0 m)

h_{inst} (window) = 3.3 ft (1.0 m)

h_{inst} (wall) = 5.9 ft (1.8 m)

h_{inst} (ceiling) = 7.2 ft (2.2 m)

Minimum area and CFM requirements for the conditioned space

Model	Charge (oz)	Minimum CFM [Q _{min}]	
		TA _{min} (ft ²)	Q _{min} (ft ³ /min)
SZ060	69	3.54	117

TA_{min} = Minimum conditioned area for venting leaked refrigerant

Q_{min} = Minimum ventilation flow rate for conditioned space if space is less than TA_{min}

Minimum area of opening for natural ventilation

Model	Charge (oz)	A _{nv} (in ²)
SZ060	69	111.57

A_{nv} = Minimum natural ventilation area opening

Models:
SZ
024-060

Minimum Installation Area

When the openings for connected rooms or natural ventilation are required, the following conditions shall be applied:

- The area of any openings above 11.8 inches (300 mm) from the floor shall not be considered in determining compliance with $An_{v_{min}}$.
- At least 50% of the required opening area $An_{v_{min}}$ shall be below 7.8 inches (200 mm) from the floor.
- The bottom of the lowest openings shall not be higher than the point of release when the unit is installed and not more than 3.9 inches (100 mm) from the floor.
- Openings are permanent openings which cannot be closed.
- For openings extending to the floor, the height shall not be less than 0.78 inch (20 mm) above the surface of the floor covering.
- A second higher opening shall be provided. The total size of the second opening shall not be less than 50% of minimum opening area for $An_{v_{min}}$ and shall be at least 3.3 ft (1.5 m) above the floor.

Refrigerant System Servicing

REFRIGERANT SYSTEM

To maintain sealed circuit integrity, do not install service gauges unless unit operation appears abnormal. Reference the operating charts for pressures and temperatures. Verify that air and water flow rates are at proper levels before servicing the refrigerant circuit.

Removal and Evacuation

When breaking into the refrigerant circuit to make repairs - or for any other purpose - conventional procedures shall be used. However, for flammable refrigerants it is important that best practice be followed, since flammability is a consideration. The following procedure shall be adhered to:

- Safely remove refrigerant following local and national regulations
- Evacuate
- Purge the circuit with Inert gas
- Evacuate
- Continuously flush or purge with Inert gas when using flame to open circuit
- Open the circuit.

The refrigerant charge shall be recovered into the correct recovery cylinders if venting is not allowed by local and national codes. For appliances containing flammable refrigerants, the system shall be purged with oxygen-free nitrogen to render the appliance safe for flammable refrigerants. This process might need to be repeated several times. Compressed air or oxygen shall not be used for purging refrigerant systems.

For appliances containing flammable refrigerants, refrigerant purging shall be achieved by breaking the vacuum in the system with oxygen-free nitrogen and continuing to fill until the working pressure is achieved, then venting to atmosphere, and finally pulling down to a vacuum (optional for FLAMMABLE REFRIGERANT). This process shall be repeated until no refrigerant is remains in the system (optional for FLAMMABLE REFRIGERANT). When the final oxygen-free nitrogen charge is used, the system shall be vented down to atmospheric pressure to enable work to take place.

The outlet for the vacuum pump shall not be close to any potential ignition sources, and ventilation shall be available.

Charging Procedures

In addition to conventional charging procedures, the following requirements shall be followed:

- Ensure that contamination of different refrigerants does not occur when using charging equipment.
- Hoses or lines shall be as short as possible to minimize the amount of refrigerant contained in them.
- Cylinders shall be kept in an appropriate position according to the instructions.
- Ensure that the REFRIGERATION SYSTEM is earthed prior to charging the system with refrigerant.
- Label the system when charging is complete (if not already).
- Extreme care shall be taken not to overfill the REFRIGERATION SYSTEM.

Prior to recharging the system, it shall be pressure-tested with the appropriate purging gas. The system shall be leak-tested on completion of charging but prior to commissioning. A follow up leak test shall be carried out prior to leaving the site.

Leak Detection

Under no circumstances shall potential sources of ignition be used in the searching for or detection of refrigerant leaks. A halide torch (or any other detector using a naked flame) shall not be used.

The following leak detection methods are deemed acceptable for all refrigerant systems.

Electronic leak detectors may be used to detect refrigerant leaks but, in the case of FLAMMABLE REFRIGERANTS, the sensitivity may not be adequate, or may need re-calibration. (Detection equipment shall be calibrated in a refrigerant-free area.) Ensure that the detector is not a potential source of Ignition and is suitable for the refrigerant used.

Models:
SZ
024-060

Refrigerant System Servicing

Leak detection equipment shall be set at a percentage of the lower flammability limit of the refrigerant and shall be calibrated to the refrigerant employed, and the appropriate percentage of gas (25% maximum) is confirmed.

Leak detection fluids are also suitable for use with most refrigerants but the use of detergents containing chlorine shall be avoided as the chlorine may react with the refrigerant and corrode the copper pipe-work.

NOTE:

Examples of leak detection fluids are:

- Bubble method
- Fluorescent method agents

If a leak is suspected, all naked flames shall be removed/extinguished.

If a refrigerant leak that requires brazing is identified, all of the refrigerant shall be recovered from the system, or isolated (by means of shut off valves) in a part of the system remote from the leak. Removal of refrigerant shall be according to Removal and Evacuation section.

Physical Data

Models:
SZ
024-060

Tranquility (SZ) Series

Model	024	030	036	042	048	060
Compressor (1 Each)	Scroll					
Number of refrigerant circuits	1	1	1	1	1	1
Factory Charge R-454B (oz)	40	36	46	56	56	69
Refrigerant Leak Detection System	O	O	O	O	O	R
Number of Sensors	2	2	2	2	2	2
Water Connection Size						
FPT - All Other (inch)	3/4"	3/4"	3/4"	3/4"	1"	1"
System Water Volume (gal)*	0.323	0.323	0.738	0.89	0.89	0.939
Vertical						
Filter Standard - 1" Throwaway (inch)	20x20	20x20	24x24	24x24	28x28	28x28
Weight - Operating (lbs.)	189	197	203	218	315	330
Weight - Packaged (lbs.)	194	202	209	224	322	337
Horizontal						
Filter Standard - 1" Throwaway	18x24	18x24	2-14x20	2-14x20	1-20x24 1-14x20	1-20x24 1-14x20
Weight - Operating (lbs.)	174	182	203	218	263	278
Weight - Packaged (lbs.)	179	187	209	224	270	285

Notes:

All dimensions displayed above are in inches unless otherwise marked.
 The standard Condensate Drain Connection is rubber coupling that couples to 3/4-inch schedule 40/80 PVC.
 The optional Stainless Steel Condensate Drain Connection is 3/4-inch FPT.
 *Volume without water options
 FPT = Female Pipe Thread.
 O = Optional, R = Required

Models:
SZ
024-060

Horizontal Installation

HORIZONTAL UNIT LOCATION

Units are not designed for outdoor installation. Locate the unit in an INDOOR area that allows enough space for service personnel to perform typical maintenance or repairs without removing unit from the ceiling. Horizontal units are typically installed above a false ceiling or in a ceiling plenum. Never install units in areas subject to freezing or where humidity levels could cause cabinet condensation (such as unconditioned spaces subject to 100% outside air). Consideration should be given to access for easy removal of the filter and access panels. Provide sufficient room to make water, electrical, and duct connection(s).

If the unit is located in a confined space, such as a closet, provisions must be made for return air to freely enter the space by means of a louvered door, etc. Any access panel screws that would be difficult to remove after the unit is installed should be removed prior to setting the unit. Refer to Figure 3 for an illustration of a typical installation. Refer to unit submittal data or engineering design guide for dimensional data.

Conform to the following guidelines when selecting unit location:

1. Provide a hinged access door in concealed-spline or plaster ceilings. Provide removable ceiling tiles in T-bar or lay-in ceilings. Refer to horizontal unit dimensions for specific series and model in unit submittal data. Size the access opening to accommodate the service technician during the removal or replacement of the compressor, control, or blower assembly.
2. Provide access to hanger brackets, water valves and fittings. Provide screwdriver clearance to access panels, discharge collars and all electrical connections.
3. DO NOT obstruct the space beneath the unit with piping, electrical cables and other items that prohibit future removal of components or the unit itself.
4. Use a manual portable jack/lift to lift and support the weight of the unit during installation and servicing.

The installation of water source heat pump units and all associated components, parts and accessories which make up the installation shall be in accordance with the regulations of ALL authorities having jurisdiction and MUST conform to all applicable codes. It is the responsibility of the installing contractor to determine and comply with ALL applicable codes and regulations.

NOTE: Minimum clearances for installation are the same as the minimum required service clearances. Consult the service clearances or reference of installation clearances for more information.

MOUNTING HORIZONTAL UNITS

Horizontal units have four hanger brackets partially attached at the factory, one at each corner. Enclosed within the unit there is a hanger kit hardware bag containing vibration isolation grommets, washers, screws and a hanger installation instruction page. One additional screw from the hardware bag must be added to each hanger bracket before unit installation. Tighten each screw to 75 in-lbs (8.5 Nm). See Figure 1 for more information. Refer to the hanger installation instruction page contained in the hardware bag for details of final hanger bracket attachment and unit suspension.

Use four field-supplied threaded rods and factory provided vibration isolators to suspend the unit. Safely lift the unit into position supporting the bottom of the unit. Ensure the top of the unit is not in contact with any external objects. Connect the top end of the four all-thread rods, slide rods through the brackets and grommet then assemble washers and double nuts at each rod. Ensure that the unit is approximately level and that the threaded rod extends past the nuts.

Figure 1: Hanger Bracket

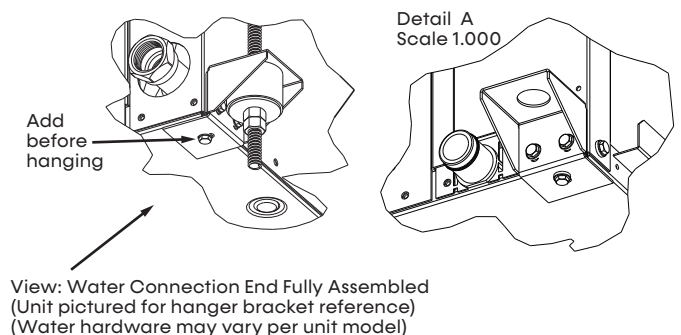

Horizontal Installation: Service Access

Models:
SZ
024-060

Left Return Back Discharge

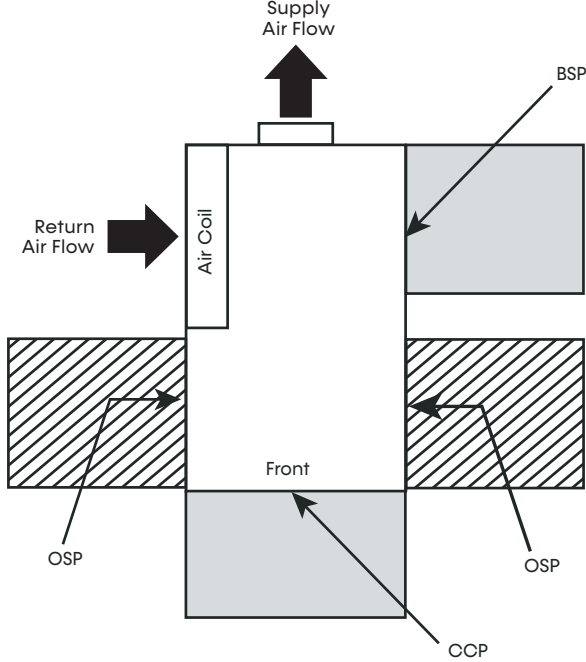

Right Return Back Discharge

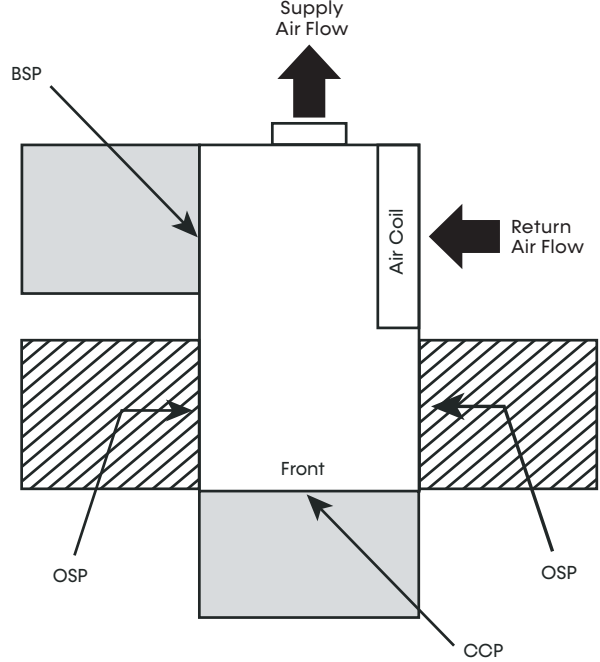

Left Return Straight Discharge

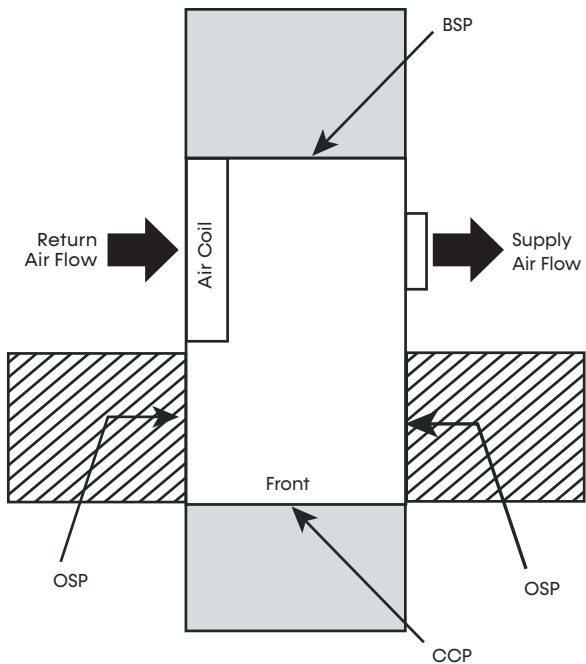

Right Return Straight Discharge

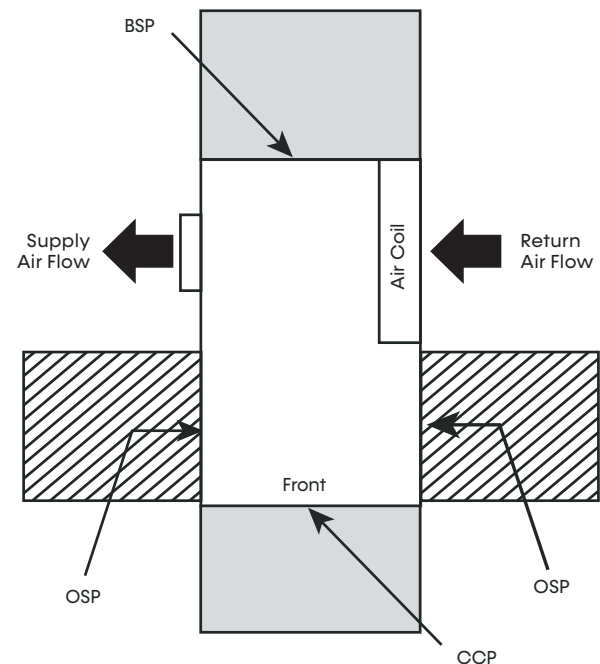

Notes:

1. While clear access to all removable panels is not required, installer should take care to comply with all building codes and allow adequate clearance for future field service.
2. CCP and BSP requires 2-feet of service access.
3. Blower service access is through back panel on straight discharge units or through panel opposite air coil on back discharge units.
4. OSP are removable panels that provide additional access to the units interior. Clear access to OSP panels is not required and they are not to be used in place of the mandatory CCP and BSP panels.

 = Mandatory Service Access 2-foot (61 cm)

 = Optional Service Access 2-foot (61 cm)

Legend:

CCP = Control/Compressor Access

BSP = Blower Service Panel

OSP = Optional Service Panel (not required)

Models:
SZ
024-060

Horizontal Installation

Figure 2: Horizontal Unit Pitch

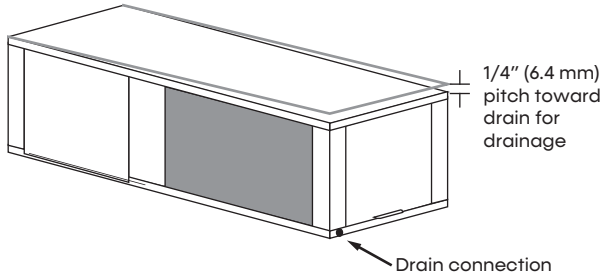
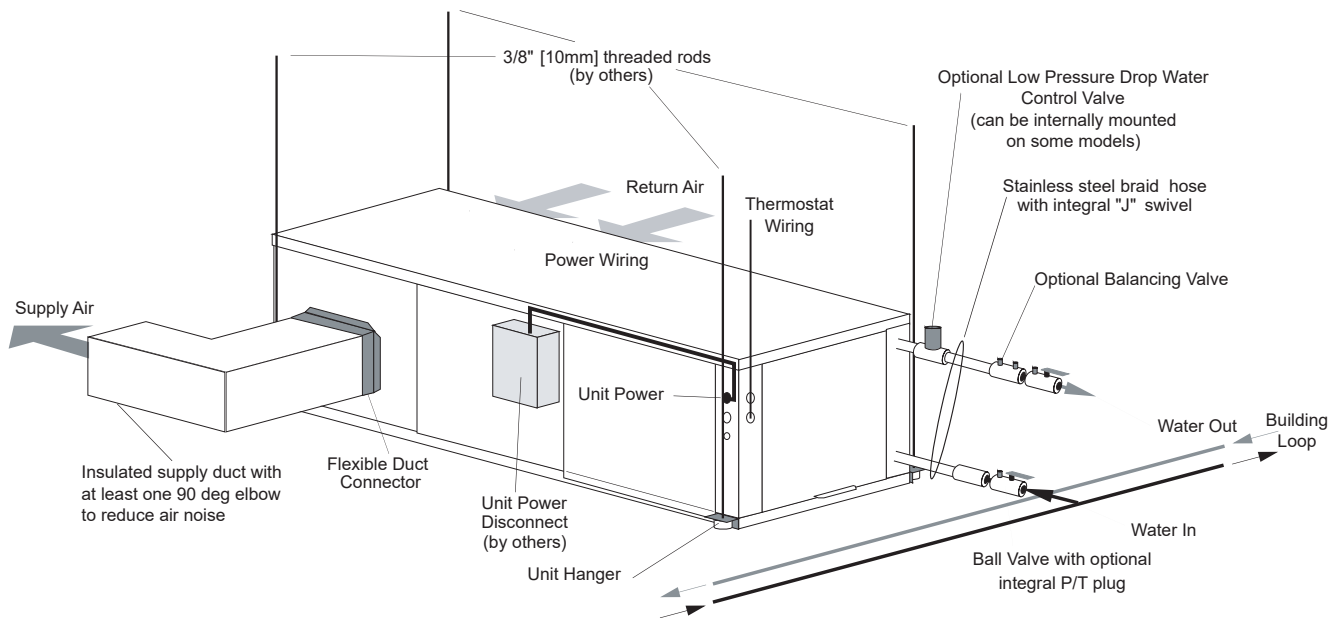

Figure 3: Typical Unit Installation



AIR COIL

To obtain maximum performance, the air coil should be cleaned before start-up. A 10% solution of dishwasher detergent and water is recommended for both sides of the coil. A thorough water rinse should follow. **Do not use Ultraviolet-based anti-bacterial systems.**

NOTICE

Installation Note - Ducted Return: Many horizontal WSHPs are installed in a return air ceiling plenum application (above ceiling). Vertical WSHPs are commonly installed in a mechanical room with free return (e.g. louvered door). Filter rails are the industry standard and are included on commercial heat pumps only for holding the filter. For ducted return applications, the filter rail must be removed and replaced with a duct flange or filter frame. Canvas or flexible connectors should also be used to minimize vibration between the unit and ductwork.

Horizontal Installation

CONDENSATE PIPING

A condensate drain line must be installed and pitched away for the unit to allow for proper drainage. This connection must meet all local plumbing/building codes.

Pitch the unit toward the drain as shown in Figure 2 to improve the condensate drainage. On small units (less than 2.5 tons/8.8 kW), ensure that unit pitch does not cause condensate leaks inside the cabinet.

Install condensate trap at each unit with the top of the trap positioned below the unit condensate drain connection as shown in Figure 4. Design the depth of the trap (water-seal) based upon the amount of ESP capability of the blower (where 2-inches [51 mm] of ESP capability requires 2-inches [51 mm] of trap depth). As a general rule, 1 ½ inch [38 mm] trap depth is the minimum.

Each unit must be installed with its own individual trap and connection to the condensate line (main) or riser. Provide a means to flush or blow out the condensate line. DO NOT install units with a common trap and/or vent.

Always vent the condensate line when dirt or air can collect in the line or a long horizontal drain line is required. Also vent when large units are working against higher external static pressure than other units connected to the same condensate main since this may cause poor drainage for all units on the line. **WHEN A VENT IS INSTALLED IN THE DRAIN LINE, IT MUST BE LOCATED AFTER THE TRAP IN THE DIRECTION OF THE CONDENSATE FLOW.**

POLYMER DRAIN PANS

Condensate drain connection is a rubber coupling that connects to ¾-inch schedule 40/80 PVC. Use hose clamps to secure the pipe inside the coupling. If the connection is not secure, the connection may leak.

Instructions for coupling the condensate drain to the trap are included in the bag that includes the coupling and hose clamps.

STAINLESS STEEL DRAIN PANS

The condensate connection is female pipe thread. Field-provided male adapter required for condensate drain connection.

Figure 4: Horizontal Condensate Connection

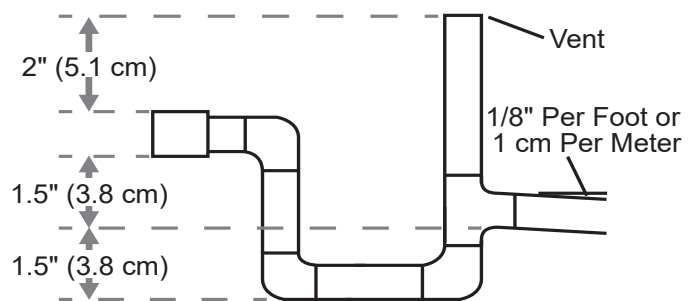

CAUTION

Ensure condensate line is pitched toward drain 1/8 inch per foot [11 mm per m] of run.

Models:
SZ
024-060

Duct System Installation

DUCT SYSTEM INSTALLATION

Proper duct sizing and design is critical to the performance of the unit. The duct system should be designed to allow adequate and even airflow through the unit during operation. Air flow through the unit **MUST** be at or above the minimum rated airflow for a given unit size to avoid equipment damage. Duct systems should be designed for quiet operation. Refer to Figure 3 for horizontal duct system details or Figure 8 for vertical duct system details. A flexible connector is recommended for both discharge and return air duct connections on metal duct systems to eliminate the transfer of vibration to the duct system. To maximize sound attenuation of the unit blower, the supply and return plenums should include internal fiberglass duct liner or be constructed from ductboard for the first few feet. Application of the unit to uninsulated ductwork in an unconditioned space is not recommended, as the unit's performance may be adversely affected.

At least one 90 degree elbow should be included in the supply duct to reduce air noise. If air noise or excessive air flow is a problem, the blower speed can be changed. For airflow charts, consult submittal data for the series and model of the specific unit.

If the unit is connected to existing ductwork, a previous check should have been made to ensure that the ductwork has the capacity to handle the airflow required for the unit. If ducting is too small, as in the replacement of a heating only system, larger ductwork should be installed. All existing ductwork should be checked for leaks and repaired as necessary.

An unventilated area where water source heat pump is installed and surpasses a R-454B refrigerant charge of 62 oz (1.76 kg), shall be without continuously operating open flames (for example an operating gas appliance) or other **POTENTIAL IGNITION SOURCES** (for example an operating electric heater, hot surfaces).

Only auxiliary electric heaters approved by ClimateMaster shall be installed in connecting ductwork. The installation of any other auxiliary devices is beyond ClimateMaster's responsibility.

For duct-connected units, false ceilings or drop ceilings may be used as a return air plenum as long as the ClimateMaster RDS is installed as shown in Figure 23.

WARNING

Ducts connected to an appliance shall not contain a **POTENTIAL IGNITION SOURCE**.

WARNING

Keep any required ventilation openings clear of obstruction.

WARNING

For mechanical ventilation, the lower edge of the air extraction opening where air is exhausted from the room shall not be more than 3.94 inches (100 mm) above the floor. The location where the mechanical ventilation air extracted from the space is discharged shall be separated by a sufficient distance, but not less than 9.84 feet (3 m), from mechanical ventilation air intake openings, to prevent recirculation to the space.

Field Conversion of Air Discharge

OVERVIEW

Horizontal unit blower assembly can be field converted between side (straight) and back (end) discharge using the instructions below.

NOTE: It is not possible to field convert return air between left or right return models due to the necessity of refrigeration copper piping changes.

PREPARATION

It is best to field convert the unit discharge configuration on the ground before hanging. If the unit is already hung it should be taken down for the field conversion.

SIDE-TO-BACK DISCHARGE CONVERSION

1. Place unit in well lit area. Remove the screws as shown in Figure 5 to free top panel and discharge panel.
2. Lift out the access panel and set aside. Lift and rotate the discharge panel to the other position as shown, being careful with the blower wiring.
3. Check blower wire routing and connections for tension or contact with sheet metal edges. Re-route if necessary.
4. Check refrigerant tubing for contact with other components.
5. Reinstall top panel and screws noting that the location for some screws will have changed.
6. Manually spin the fan wheel to ensure that the wheel is not rubbing or obstructed.
7. Replace access panels.

BACK-TO-SIDE DISCHARGE CONVERSION

If the discharge is changed from back to side, use above instruction noting that illustrations are reversed.

LEFT VERSUS RIGHT RETURN

It is not possible to field convert return air between left or right return models due to the necessity of refrigeration copper piping changes. However, the conversion process of side-to-back or back-to-side discharge for either right or left return configuration is the same. In some cases, it may be possible to rotate the entire unit 180 degrees if the return air connection needs to be on the opposite side. **NOTE: rotating the unit moves the piping to the other end of the unit.**

Figure 5: Left Return – Side-to-Back

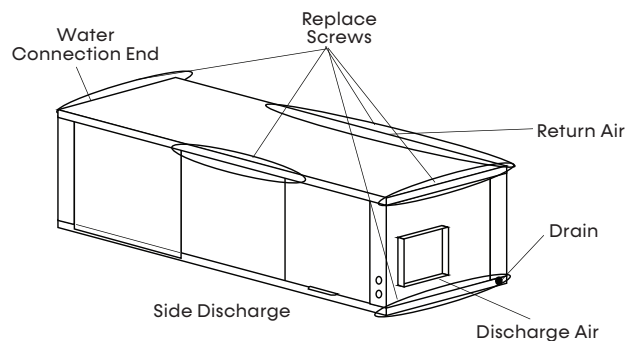
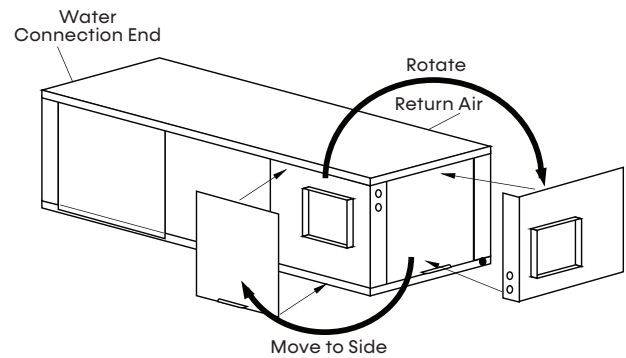
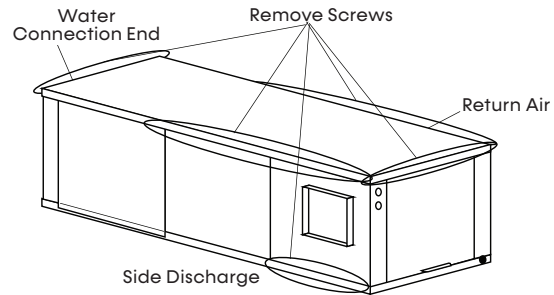
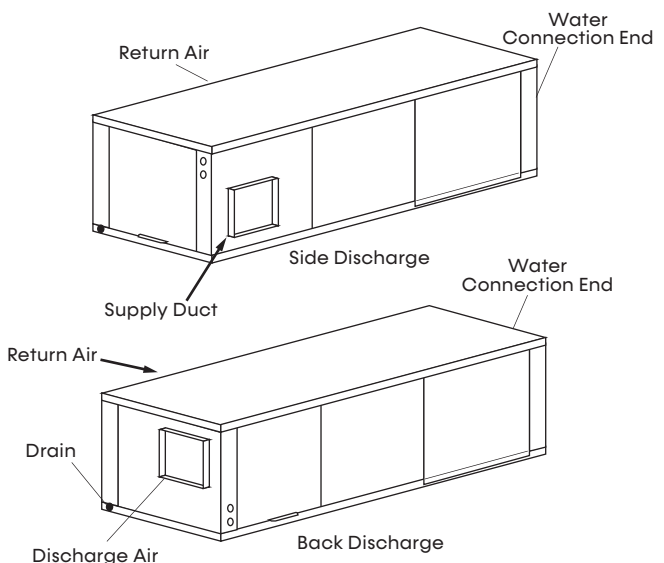

Figure 6: Right Return – Side-to-Back



Models:
SZ
024-060

Vertical Installation

VERTICAL UNIT LOCATION

Units are not designed for outdoor installation. Locate the unit in an INDOOR area that allows enough space for service personnel to perform typical maintenance or repairs without removing unit from the mechanical room/closet. Never install units in areas subject to freezing or where humidity levels could cause cabinet condensation (such as unconditioned spaces subject to 100% outside air). Consideration should be given to access for easy removal of the filter and access panels. Provide sufficient room to make water, electrical, and duct connection(s). **NOTE: Minimum clearances for installation are the same as the minimum required service clearances. Consult the service clearances on for reference of installation clearances.**

If the unit is located in a confined space, such as a closet, provisions must be made for return air to freely enter the space by means of a louvered door, etc. Any access panel screws that would be difficult to remove after the unit is installed should be removed prior to setting the unit. Refer to the figures to the right for typical installation illustrations. Refer to submittal data or the engineering design guide for dimensional data.

1. Install the unit on a piece of rubber, neoprene, or other mounting pad material for sound isolation. The pad should be at least 3/8-inch [10 mm] to 1/2-inch [13 mm] in thickness. The vibration isolation pad should cover the entire base of the unit and slightly extend past all four edges of the base.
2. Provide adequate clearance for filter replacement and drain pan cleaning. Do not block filter access with piping, conduit or other materials. Refer to unit submittal data or engineering design guide for dimensional data.
3. Provide access for fan and fan motor maintenance and for servicing the compressor and coils without removing the unit.
4. Provide an unobstructed path to the unit within the closet or mechanical room. Space should be sufficient to allow removal of the unit, if necessary.
5. In limited side access installations, pre-removal of the control box side mounting screws will allow control box removal for future servicing.
6. Provide access to water valves and fittings and screwdriver access to the unit side panels, discharge collar and all electrical connections.

Figure 7: Vertical Unit Mounting

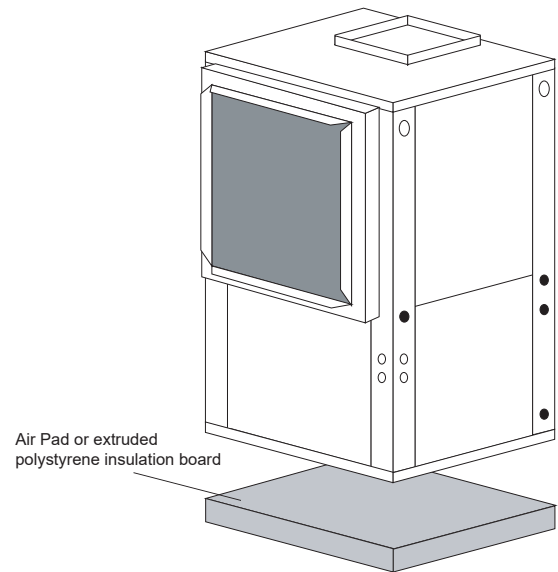
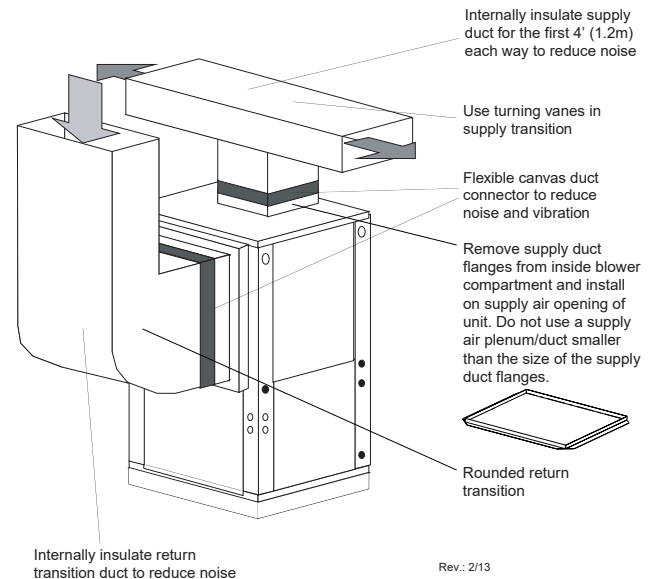

Figure 8: Typical Vertical Unit Installation Using Ducted Return Air



NOTICE

Installation Note - Ducted Return: Many horizontal WSHPs are installed in a return air ceiling plenum application (above ceiling). Vertical WSHPs are commonly installed in a mechanical room with free return (e.g. louvered door). Filter rails are the industry standard and are included on commercial heat pumps only for holding the filter. For ducted return applications, the filter rail must be removed and replaced with a duct flange or filter frame. Canvas or flexible connectors should also be used to minimize vibration between the unit and ductwork.

Vertical Installation

SOUND ATTENUATION FOR VERTICAL UNITS

Sound attenuation is achieved by enclosing the unit within a small mechanical room or a closet. Additional measures for sound control include the following:

1. Mount the unit so that the return air inlet is 90 degrees to the return air grille. Refer to the figure below. Install a sound baffle as illustrated to reduce line-of-sight sound transmitted through return air grilles.
2. Mount the unit on a rubber or neoprene isolation pad to minimize vibration transmission to the building structure.

Figure 10: Vertical Sound Attenuation

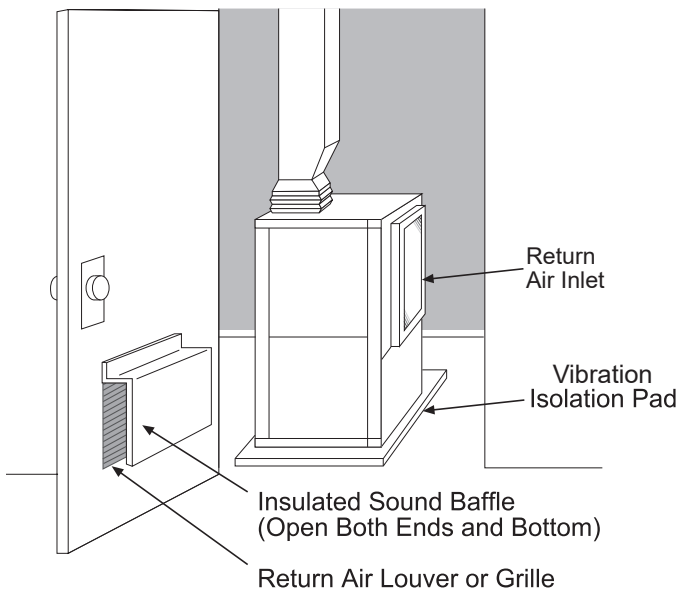

CONDENSATE PIPING FOR VERTICAL UNITS

A condensate line must be installed and pitched away from the unit to allow for proper drainage. This connection must meet all local plumbing and building codes.

Install condensate trap at each unit with the top of the trap positioned below the unit condensate drain connection. Design the depth of the trap (water-seal) based upon the amount of ESP capability of the blower (where 2-inches [51 mm] of ESP capability requires 2-inches [51 mm] of trap depth). As a general rule, 1-½ inches [38 mm] of trap depth is the minimum.

Always vent the condensate line when dirt or air can collect in the line or a long horizontal drain line is required. Also vent when large units are working against higher external static pressure than other units connected to the same condensate main since this may cause poor drainage for all units on the line. **WHEN A VENT IS INSTALLED IN THE DRAIN LINE, IT MUST BE LOCATED AFTER THE TRAP IN THE DIRECTION OF THE CONDENSATE FLOW.**

Each unit must be installed with its own individual vent (where necessary) and a means to flush or blow out the condensate drain line. Do not install units with a common trap and/or vent.

Condensate drain connection is a rubber coupling that couples to ¾-inch schedule 40/80 PVC. Use hose clamps to secure the pipe inside the coupling. If the connection is not secure, the connection may leak.

Instructions for coupling the condensate drain to the trap are included in the bag that includes the coupling and hose clamps.

Figure 9: Vertical Condensate Drain

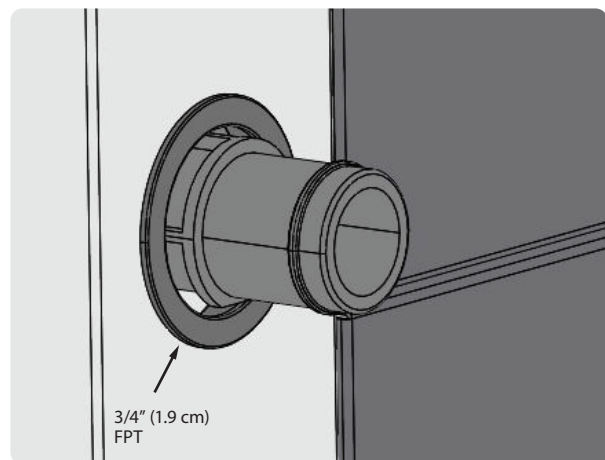

Models:
SZ
024-060

Vertical Installation: Service Access

Vertical Units

Left Return

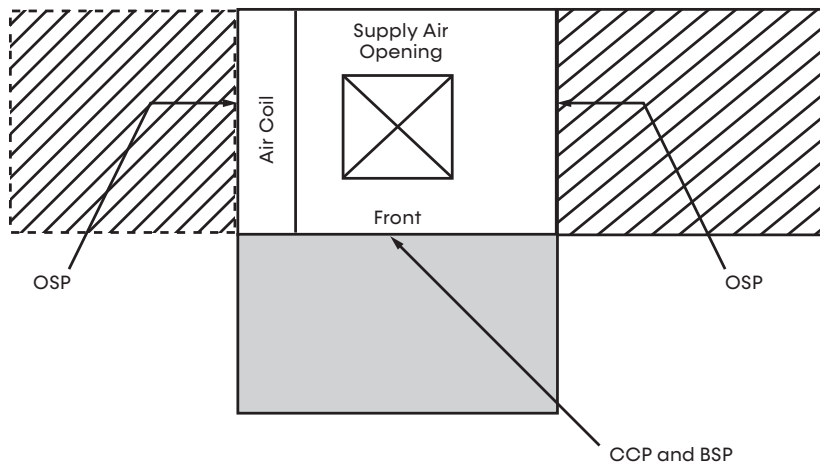

Right Return

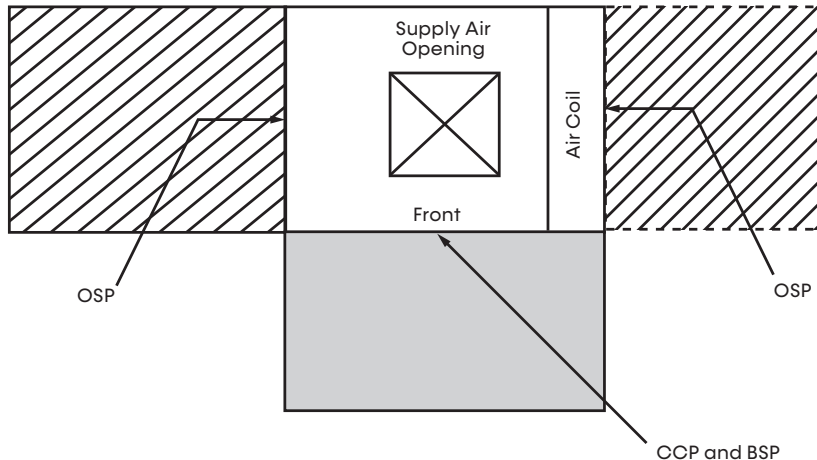

Notes:

1. While clear access to all removable panels is not required, installer should take care to comply with all building codes and allow adequate clearance for future field service.
2. Front and side access is preferred for service access. However, all components may be serviced from the front access panel if side access is not available.
3. OSP are removable panels that provide additional access to the units interior. Clear access to OSP panels is not required and they are not to be used in place of the mandatory CCP and BSP panels.
4. Top supply air is shown, the same clearances apply to bottom supply air units.

 = Mandatory Service Access 2-foot (61 cm)

 = Optional Service Access 2-foot (61 cm)

Legend:

CCP = Control/Compressor Access

BSP = Blower Service Panel

OSP = Optional Service Panel (not required)

Piping Installation

INSTALLATION SUPPLY AND RETURN PIPING

Follow these piping guidelines:

1. Install a drain valve at the base of each supply and return riser to facilitate system flushing.
2. Install shut-off/balancing valves and unions at each unit to permit unit removal for servicing.
3. Place strainers at the inlet of each system circulating pump.
4. Select the proper hose length to allow slack between connection points. Hoses may vary in length by +2% to -4% under pressure.
5. Refer to Table 2. Do not exceed the minimum bend radius for the hose selected. Exceeding the minimum bend radius may cause the hose to collapse, which reduces water flow rate. Install an angle adapter to avoid sharp bends in the hose when the radius falls below the required minimum.

Insulation is not required on loop water piping except where the piping runs through unheated areas, outside the building or when the loop water temperature is below the minimum expected dew point of the pipe ambient conditions. Insulation is required if loop water temperature drops below the dew point (insulation is required for ground loop applications in most climates).

Pipe joint compound is not necessary when water thread sealant tape is pre-applied to hose assemblies or when flared-end connections are used. If pipe joint compound is preferred, use compound only in small amounts on the external pipe threads of the fitting adapters. Prevent sealant from reaching the flared surfaces of the joint.

NOTE: When antifreeze is used in the water loop, ensure that it is compatible with the thread-sealant tape or pipe-joint compound that is applied.

Maximum allowable torque for brass fittings is 30 ft-lbs [41 N-m]. If a torque wrench is not available, tighten finger-tight plus one quarter turn. Tighten steel fittings as necessary.

Optional pressure-rated hose assemblies designed specifically for use with ClimateMaster units are available. Similar hoses can be obtained from alternate suppliers. Supply and return hoses are fitted with swivel-joint fittings at one end to prevent kinking during installation.

The figure below illustrates a typical supply/return hose kit. Adapters secure hose assemblies to the unit and risers. Install hose assemblies properly and check regularly to avoid system failure and reduced service life.

⚠ WARNING

Polyolester Oil, commonly known as POE oil, is a synthetic oil used in many refrigeration systems including those with R-454B refrigerant. POE oil, if it ever comes in contact with PVC or CPVC piping, may cause failure of the PVC/CPVC. PVC/CPVC piping should never be used as supply or return water piping with water source heat pump products containing R-454B as system failures and property damage may result.

⚠ CAUTION

Corrosive system water requires corrosion resistant fittings and hoses, and may require water treatment.

⚠ CAUTION

Do not bend or kink supply lines or hoses.

⚠ CAUTION

Piping must comply with all applicable codes.

Table 2: Metal Hose Minimum Bend Radius

Hose Diameter	Minimum Bend Radius
1/2" [12.7 mm]	2-1/2" [6.4 cm]
3/4" [19.1 mm]	4" [10.2 cm]
1" [25.4 mm]	5-1/2" [14 cm]
1-1/4" [31.8 mm]	6-3/4" [17.1 cm]

⚠ NOTICE

Do not allow hoses to rest against structural building components. Compressor vibration may be transmitted through the hoses to the structure, causing unnecessary noise complaints.

Figure 11: Supply/Return Hose Kit

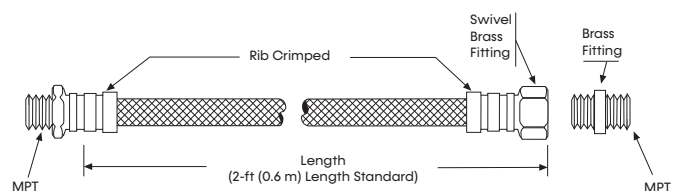

Models:
SZ
024-060

vFlow Heat Pump Applications Overview

vFlow® is a revolutionary new, intelligent, and efficient way to circulate water (or water plus antifreeze) using internal, variable speed water flow control. The factory installed high efficiency variable speed pumps uses almost half the wattage of traditional fixed speed pump. vFlow technology improves the life expectancy of the unit by reducing the amount of energy required to optimize the flow of water throughout the system and also reduces the space, cost, and labor required to install external water flow control mechanisms (flow controllers, solenoid and flow control valves).

vFLOW CONFIGURATIONS

1. Low System Pressure Drop Modulating Motorized Valve – Typical for External Central Pumping.

Primarily for use on multi-unit applications with central pumping. With this option the unit includes a low pressure drop, high CV modulating motorized water valve that is controlled by the DXM2.5 control based on the difference in the entering and leaving water temperature delta T. This valve is a standard factory installed feature for the Tranquility SZ.

2. High System Pressure Drop Modulating Motorized Valve – Typical for High Pressure Water System such as Water Well Pumps.

With this option the unit includes a high pressure drop modulating water valve that is controlled by the DXM2.5 control based on the difference in the entering and leaving water temperature delta T. A low Cv valve is used to provide more precise control against high system pressure differential type of loops. This valve is a factory installed option for the Tranquility SZ and when selected replaces the modulating valve.

3. Standard Head Variable Pump – Typical for Multiple Unit Central Pumping.

With this option the unit includes an internal variable speed pump that is best suited to low pressure drop systems such as primary/secondary pumping. The pump speed is controlled by the DXM2.5 control based on the difference in the entering and leaving water temperature delta T. This pump includes an internal check valve for multiple unit installations. This pump is a factory installed option for the Tranquility SZ and when selected replaces the modulating valve.

4. High Head Variable Pump – Typical for Individual Unit Pumping.

With this option the unit includes an internal variable speed pump that is capable of higher system pressure drops. The pump speed is controlled by the DXM2.5 control based on the difference in the entering and leaving water temperature delta T. This pump includes an internal check valve for multiple unit installations. This pump is a factory installed option for the Tranquility SZ and when selected replaces the modulating valve.

Variable speed pump or motorized modulating valve delivers variable water-flow, controlled by DXM2.5 control, based on loop water ΔT .



Typical Closed-Loop Application (Shown with Internal Variable Pump)

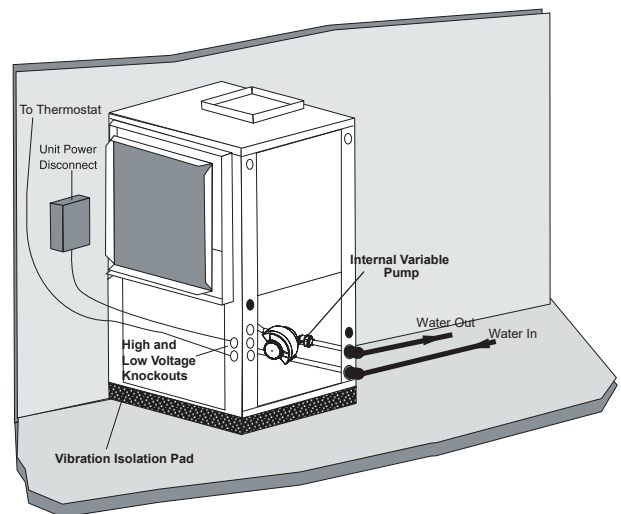

vFlow Heat Pump Applications Overview

Typical Open Loop Application (Shown with Internal Modulating Motorized Valve)

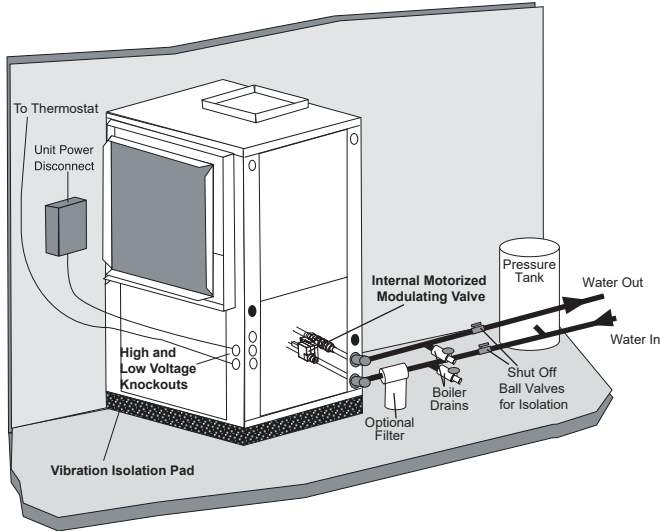

For use on applications using external source for flow.

WATER PRESSURE SCHRADER PORTS

The pressure ports built in to the unit are provided as a means of measuring pressure drop through the water-to-refrigerant heat exchanger. The water pressure ports are schrader ports smaller than refrigerant schrader ports. They are the same size as tire schrader ports. A digital pressure gauge is recommended for taking pressure readings through these ports. The water flow through the unit can be determined by measuring the water pressure at the “water pressure out” port and subtracting it from the water pressure at the “water pressure in” port. Comparing the pressure differential to the pressure drop table (wpd)/flow rate in Table 7 in this manual will determine the flow rate through the unit.

High System Pressure Drop Valve

Model	CV	MOPD	WPD Adders		
			GPM	PSI	FT
SZ*024	4.7	200	3.0	0.41	0.94
	4.7	200	4.5	0.92	2.12
	4.7	200	6.0	1.63	3.76
SZ*030	4.7	200	3.8	0.65	1.51
	4.7	200	5.6	1.42	3.28
SZ*036	4.7	200	4.5	0.92	2.12
	4.7	200	6.8	2.09	4.84
	4.7	200	9.0	3.67	8.47
SZ*042	4.7	200	5.3	1.27	2.94
	4.7	200	7.9	2.83	6.53
SZ*048	4.7	200	10.5	4.99	11.53
	4.7	200	6.0	1.63	3.76
	4.7	200	9.0	3.67	8.47
SZ*060	4.7	200	12.0	6.52	15.06
	7.4	200	7.0	.89	2.06
	7.4	200	10.5	2.01	4.64
	7.4	200	14.0	3.58	8.26

Low System Pressure Drop Valve

Model	CV	MOPD	WPD Adders		
			GPM	PSI	FT
SZ*024	4.7	200	3.0	0.41	0.94
	4.7	200	4.5	0.92	2.12
	4.7	200	6.0	1.63	3.76
SZ*030	7.4	200	3.8	0.26	0.61
	7.4	200	5.6	0.57	1.32
SZ*036	7.4	200	7.5	1.03	2.37
	7.4	200	4.5	0.37	0.85
	7.4	200	6.8	0.84	1.95
SZ*042	7.4	200	9.0	1.48	3.42
	10.0	200	5.3	0.28	0.65
	10.0	200	7.9	0.62	1.44
SZ*048	10.0	200	10.5	1.10	2.55
	10.0	200	6.0	0.36	0.83
	10.0	200	9.0	0.81	1.87
SZ*060	10.0	200	12.0	1.44	3.33
	19.0	200	7.0	0.14	0.31
	19.0	200	10.5	0.31	0.70
	19.0	200	14.0	0.54	1.25

Models:
SZ
024-060

vFlow Heat Pump Applications Overview

Standard Head Variable Pump Performance

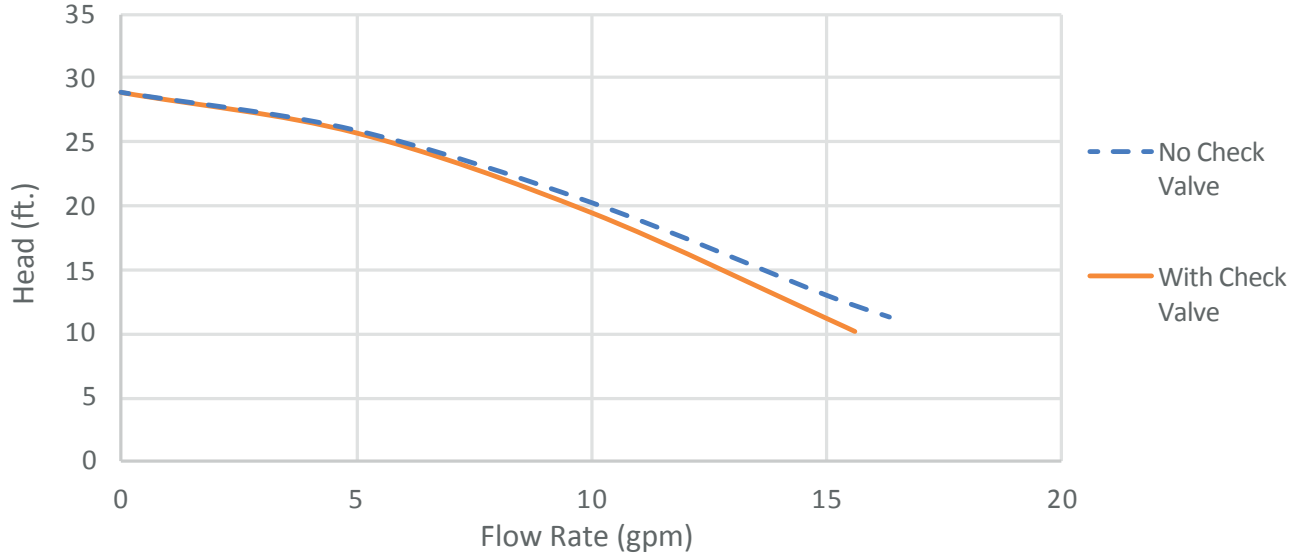

High Head Variable Pump Performance

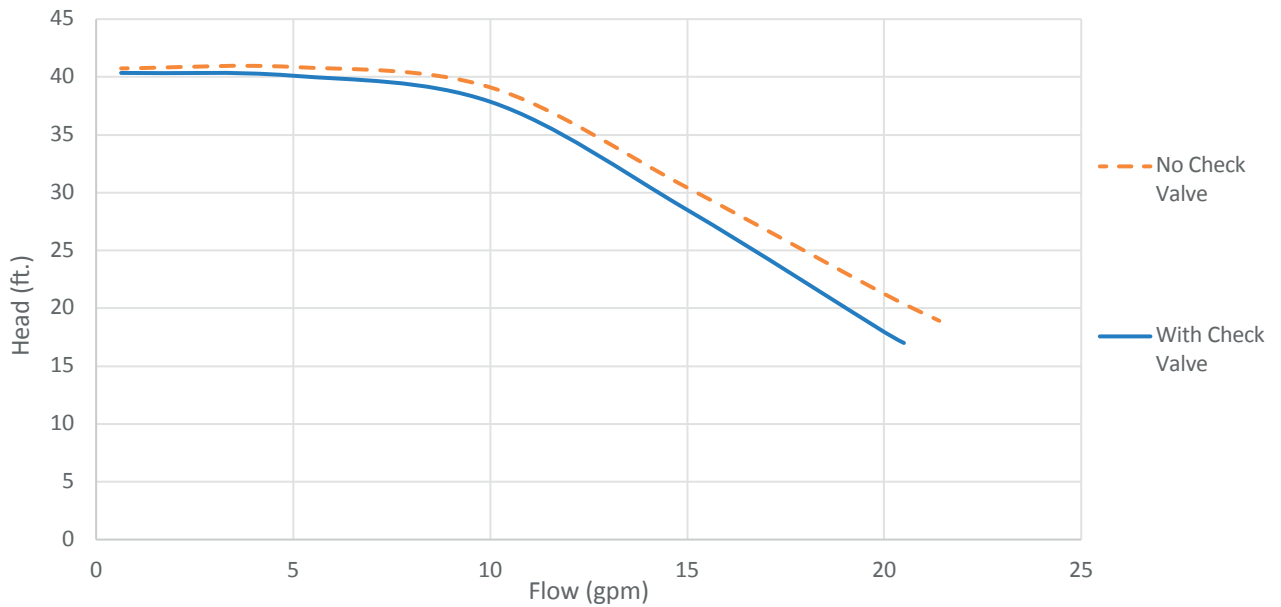

Water-Loop Heat Pump Applications

COMMERCIAL WATER LOOP APPLICATIONS

Commercial systems typically include a number of units connected to a common piping system. Any unit plumbing maintenance work can introduce air into the piping system; therefore air elimination equipment is a major portion of the mechanical room plumbing. Consideration should be given to insulating the piping surfaces to avoid condensation. ClimateMaster recommends piping insulation any time the water temperature is below 60°F (15.6°C). Metal to plastic threaded joints should never be used due to their tendency to leak over time.

Water thread sealant tape thread sealant is recommended to minimize internal fouling of the heat exchanger. Do not over tighten connections and route piping so as not to interfere with service or maintenance access. Hose kits are available from ClimateMaster in different configurations for connection between the unit and the piping system. Depending upon selection, hose kits may include shut off valves, P/T plugs for performance measurement, high pressure stainless steel braided hose, "Y" type strainer with blow down valve, and/or with blow down valve, auto-flow valve and swivel connections.

The piping system should be flushed to remove dirt, piping chips, and other foreign material prior to operation (see Piping System Cleaning and Flushing in this manual). The flow rate is usually set between 2.25 and 3.5 gpm per ton (2.9 and 4.5 l/m per kW) of cooling capacity. ClimateMaster recommends 3 gpm per ton (3.9 l/m per kW) for most water-loop heat pump applications. To ensure proper maintenance and servicing, P/T ports are imperative for temperature, flow verification, and performance checks.

Water-loop heat pump (cooling tower/boiler) systems typically utilize a common loop, maintained between 60 - 90°F (16 - 32°C). The use of a closed circuit evaporative cooling tower with a secondary heat exchanger between the tower and the water loop is recommended. If an open type cooling tower is used continuously, chemical treatment and filtering will be necessary.

Models:
SZ
024-060

Ground-Loop Heat Pump Applications

CAUTION

The following instructions represent industry accepted installation practices for closed loop earth coupled heat pump systems. Instructions are provided to assist the contractor in installing trouble free ground loops. These instructions are recommendations only. State/provincial and local codes MUST be followed and installation MUST conform to ALL applicable codes. It is the responsibility of the installing contractor to determine and comply with ALL applicable codes and regulations.

CAUTION

Ground loop applications require extended range equipment and optional refrigerant/water circuit insulation.

Test individual horizontal loop circuits before backfilling. Test vertical U-bends and pond loop assemblies prior to installation. Pressures of at least 100 psi (689 kPa) should be used when testing. Do not exceed the pipe pressure rating. Test entire system when all loops are assembled.

PRE-INSTALLATION

Prior to installation, locate and mark all existing underground utilities, piping, etc. Install loops for new construction before sidewalks, patios, driveways, and other construction has begun. During construction, accurately mark all ground loop piping on the plot plan as an aid in avoiding potential future damage to the installation.

PIPING INSTALLATION

All earth loop piping materials should be limited to polyethylene fusion only for in-ground sections of the loop. Galvanized or steel fittings should not be used at any time due to their tendency to corrode. All plastic to metal threaded fittings should be avoided due to their potential to leak in earth coupled applications. A flanged fitting should be substituted. P/T plugs should be used so that flow can be measured using the pressure drop of the unit heat exchanger.

Earth loop temperatures can range between 25 and 110°F (-4 to 43°C). Flow rates between 2.25 and 3 gpm (2.41 to 3.23 l/m per kW) of cooling capacity is recommended in these applications.

FLUSHING THE EARTH LOOP

Upon completion of system installation and testing, flush the system to remove all foreign objects and purge to remove all air.

ANTIFREEZE

In areas where minimum entering loop temperatures drop below 40°F (5°C) or where piping will be routed through areas subject to freezing, antifreeze is required. Alcohols and glycols are commonly used as antifreeze; however your local sales office should be consulted to determine the antifreeze best suited to your area. Freeze protection should be maintained to 15°F (9°C) below the lowest expected entering loop temperature. For example, if 30°F (-1°C) is the minimum expected entering loop temperature, the leaving loop temperature would be 22 to 25°F (-6 to -4°C) and freeze protection should be at 15°F (-10°C).

Calculation is as follows:

$$30^{\circ}\text{F} - 15^{\circ}\text{F} = 15^{\circ}\text{F} \quad [-1^{\circ}\text{C} - 9^{\circ}\text{C} = -10^{\circ}\text{C}]$$

All alcohols should be premixed and pumped from a reservoir outside of the building when possible or introduced under the water level to prevent fumes. Calculate the total volume of fluid in the piping system. Then use the percentage by volume shown in the table below for the amount of antifreeze needed. Antifreeze concentration should be checked from a well mixed sample using a hydrometer or refractometer to measure specific gravity.

Table 3: Antifreeze Percentages by Volume

Type	Minimum Temperature for Low Temperature Protection			
	10°F [-12.2°C]	15°F [-9.4°C]	20°F [-6.7°C]	25°F [-3.9°C]
Methanol	25%	21%	16%	10%
100% USP food grade Propylene Glycol	38%	25%	22%	15%
Ethanol*	29%	25%	20%	14%

* Must not be denatured with any petroleum based product

Ground-Loop Heat Pump Applications

Figure 12: Ground-Loop Heat Pump Applications

Typical Closed Loop with Central Pumping (unit with internal modulating water valve)

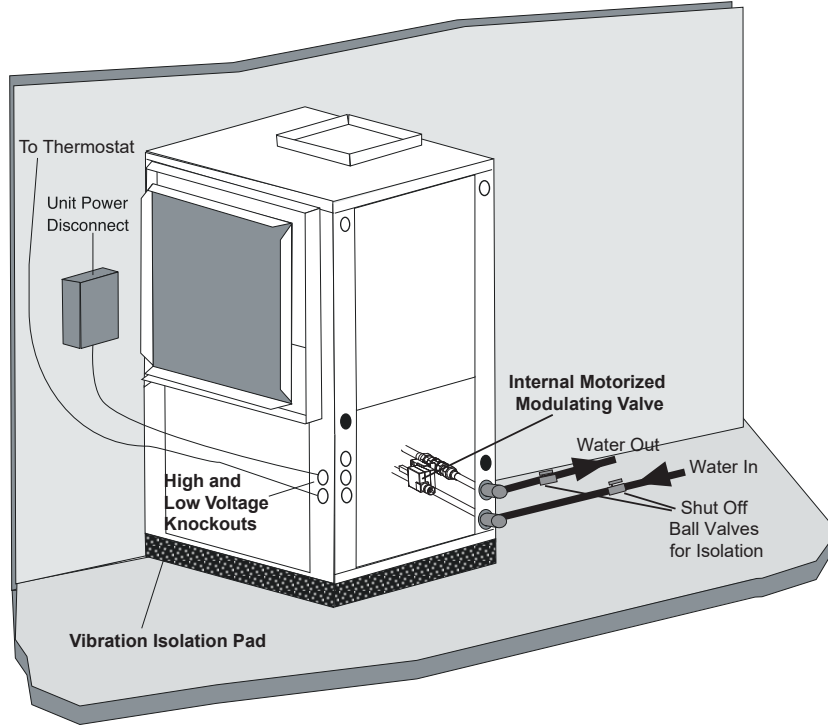
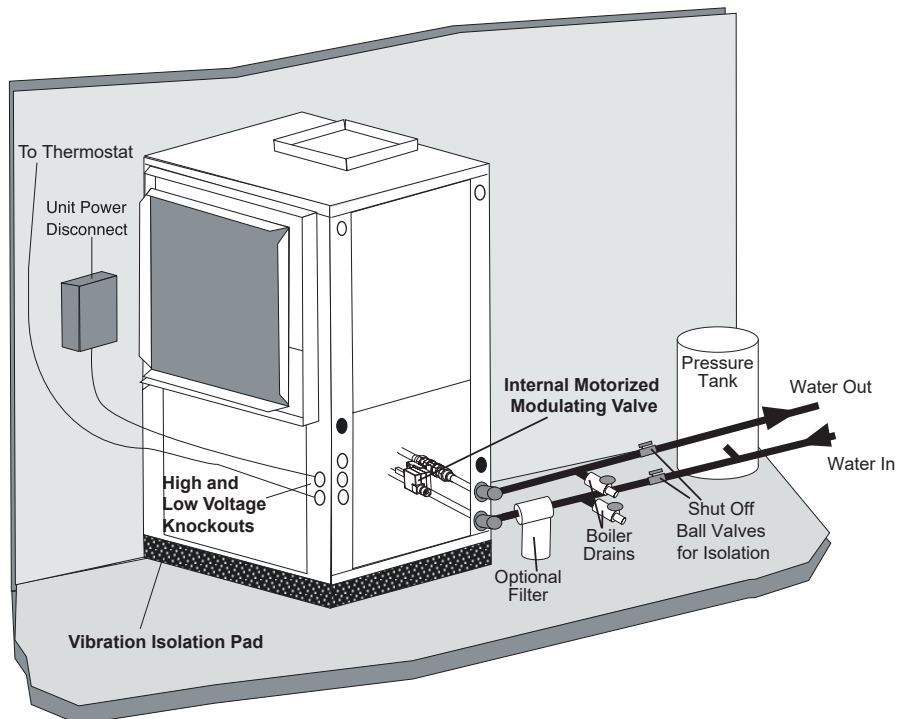

Figure 13: Ground Water Heat Pump Applications

Typical Open Loop/Well (unit with internal modulating water valve)



Models:
SZ
024-060

Ground-Water Heat Pump Applications

OPEN LOOP: GROUND WATER SYSTEMS

Typical open loop piping is shown in accompanying illustration. Shut off valves should be included for ease of servicing. Boiler drains or other valves should be “tee’d” into the lines to allow acid flushing of the heat exchanger. Shut off valves should be positioned to allow flow through the coax via the boiler drains without allowing flow into the piping system. P/T plugs should be used with units that do not include vFlow® so that flow can be measured using the pressure drop of the unit heat exchanger. Units equipped with any of the four vFlow configurations have built in Schrader ports. Water temperature may be viewed on the Communicating (AWC) Thermostat. Supply and return water piping should be limited to copper, HPDE, or other acceptable high temperature material. Note that PVC or CPVC material is not recommended as they are not compatible with the polyolester oil used in R-454B products.

WARNING

Polyolester Oil, commonly known as POE oil, is a synthetic oil used in many refrigeration systems including those with R-454B refrigerant. POE oil, if it ever comes in contact with PVC or CPVC piping, may cause failure of the PVC/CPVC. PVC/CPVC piping should never be used as supply or return water piping with water source heat pump products containing R-454B as system failures and property damage may result.

Water quantity should be plentiful and of good quality. Consult Table 4 for water quality guidelines. The unit can be ordered with either a copper or cupro-nickel water heat exchanger. Consult Table 4 for recommendations. Copper is recommended for closed loop systems and open loop ground water systems that are not high in mineral content or corrosiveness. In conditions anticipating heavy scale formation or in brackish water, a cupro-nickel heat exchanger is recommended. In ground water situations where scaling could be heavy or where biological growth such as iron bacteria will be present, an open loop system is not recommended. Heat exchanger coils may over time lose heat exchange capabilities due to build up of mineral deposits. Heat exchangers must only be serviced by a qualified technician, as acid and special pumping equipment is required. Desuperheater coils can likewise become scaled and possibly plugged.

In areas with extremely hard water, the owner should be informed that the heat exchanger may require occasional acid flushing. In some cases, the desuperheater option should not be recommended due to hard water conditions and additional maintenance required.

WATER QUALITY REQUIREMENTS

Table 4 should be consulted for water quality requirements. Scaling potential should be assessed using the pH/Calcium hardness method. If the pH <7.5 and the calcium hardness is less than 100 ppm, scaling potential is low. If this method yields numbers out of range of those listed, the Ryznar Stability and Langelier Saturation indices should be calculated. Use the appropriate scaling surface temperature for the application, 150°F [66°C] for direct use (well water/open loop) and DHW (desuperheater); 90°F [32°F] for indirect use. A monitoring plan should be implemented in these probable scaling situations. Other water quality issues such as iron fouling, corrosion prevention and erosion and clogging should be referenced in Table 4.

EXPANSION TANK AND PUMP

Use a closed, bladder-type expansion tank to minimize mineral formation due to air exposure. The expansion tank should be sized to provide at least one minute continuous run time of the pump using its drawdown capacity rating to prevent pump short cycling. Discharge water from the unit is not contaminated in any manner and can be disposed of in various ways, depending on local building codes (e.g. recharge well, storm sewer, drain field, adjacent stream or pond, etc.). Most local codes forbid the use of sanitary sewer for disposal. Consult your local building and zoning department to assure compliance in your area.

Ground-Water Heat Pump Applications

FLOW REGULATION: UNITS WITHOUT VFLOW

Flow regulation can be accomplished by two methods. One method of flow regulation involves simply adjusting the ball valve or water control valve on the discharge line. Measure the pressure drop through the unit heat exchanger, and determine flow rate from Table 7. Since the pressure is constantly varying, two pressure gauges may be needed. Adjust the valve until the desired flow of 1.5 to 2 gpm per ton [2.0 to 2.6 l/m per kW] is achieved. A second method of flow control requires a flow control device mounted on the outlet of the water control valve. The device is typically a brass fitting with an orifice of rubber or plastic material that is designed to allow a specified flow rate. On occasion, flow control devices may produce velocity noise that can be reduced by applying some back pressure from the ball valve located on the discharge line. Slightly closing the valve will spread the pressure drop over both devices, lessening the velocity noise.

NOTE: When EWT is below 50°F [10°C], 2 gpm per ton (2.6 l/m per kW) is required.

Figure 14: Typical Open Loop/Well Application

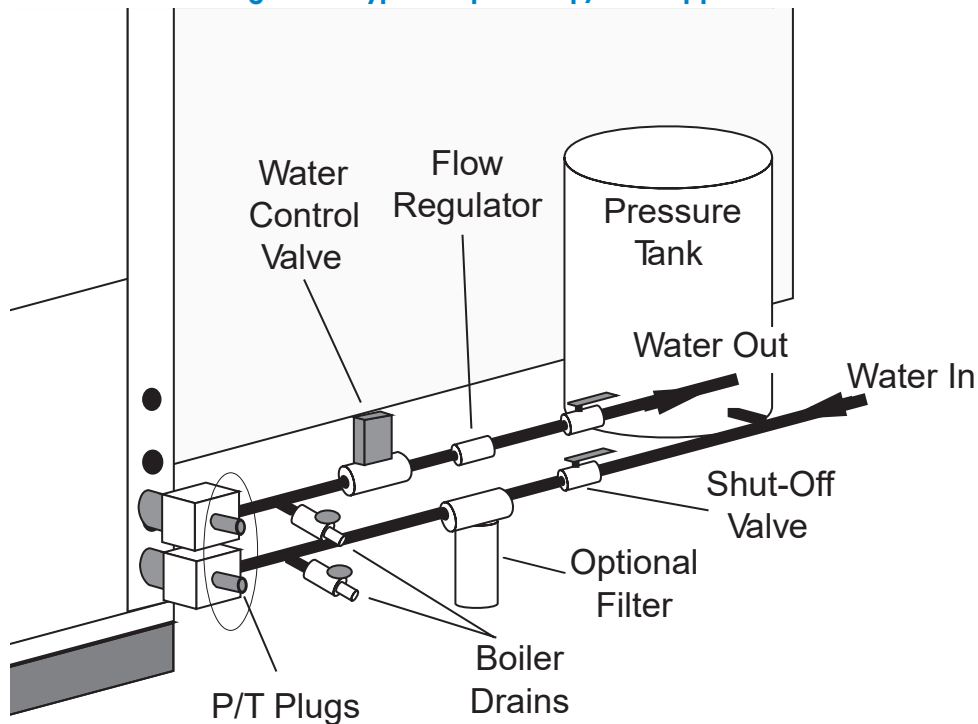

Models:
SZ
024-060

Water Quality Requirements

Table 4: Water Quality Requirements

Clean water is essential to the performance and life span of water source heat pumps. Contaminants, chemicals, and minerals all have the potential to cause damage to the water heat exchanger if not treated properly. All closed water loop systems should undergo water quality testing and be maintained to the water quality standards listed in this table.

Water Quality Requirements For Closed-Loop and Open-Loop Systems							
	Description	Symbol	Units	Heat Exchanger Type			
				Closed Loop Recirculating		Open Loop, Tower, Ground Source Well	
				All Heat Exchanger Types	Coaxial HX Copper Tube in Tube	Coaxial HX Cupronickel	Brazed- Plate HX 316 SS
Scaling Potential	pH - Chilled Water <85°F			7.0 to 9.0	7.0 to 9.0	7.0 to 9.0	7.0 to 9.0
	pH - Chilled Water >85°F			8.0 to 10.0	8.0 to 10.0	8.0 to 10.0	8.0 to 10.0
	Alkalinity	(HCO ₃ ⁻)	ppm - CaCO ₃ equivalent	50 to 500	50 to 500	50 to 500	50 to 500
	Calcium	(Ca)	ppm	<100	<100	<100	<100
	Magnesium	(Mg)	ppm	<100	<100	<100	<100
	Total Hardness	(CaCO ₃)	ppm - CaCO ₃ equivalent	30 to 150	150 to 450	150 to 450	150 to 450
	Langelier Saturation Index	LSI		-0.5 to +0.5	-0.5 to +0.5	-0.5 to +0.5	-0.5 to +0.5
	Ryznar Stability Index	RSI		6.5 to 8.0	6.5 to 8.0	6.5 to 8.0	6.5 to 8.0
Corrosion Prevention	Total Dissolved Solids	(TDS)	ppm - CaCO ₃ equivalent	<1000	<1000	<1000	<1000
	Sulfate	(SO ₄ ²⁻)	ppm	<200	<200	<200	<200
	Nitrate	(NO ₃ ⁻)	ppm	<100	<100	<100	<100
	Chlorine (free)	(Cl)	ppm	<0.5	<0.5	<0.5	<0.5
	Chloride (water < 80°F)	(Cl ⁻)	ppm	<20	<20	<150	<150
	Chloride (water > 120°F)	(Cl ⁻)	ppm	<20	<20	<125	<125
	Hydrogen Sulfide ^a	(H ₂ S)	ppb	<0.5	<0.5	<0.5	<0.5
	Carbon Dioxide	(CO ₂)	ppm	0	<50	10 to 50	10 to 50
	Iron Oxide	(Fe)	ppm	<1.0	<1.0	<1.0	<0.2
	Manganese	(Mn)	ppm	<0.4	<0.4	<0.4	<0.4
	Ammonia	(NH ₃)	ppm	<0.05	<0.1	<0.1	<0.1
	Chloramine	(NH ₂ CL)	ppm	0	0	0	0
Fouling & Biological	Iron bacteria		cells/mL	0	0	0	0
	Slime-forming bacteria		cells/mL	0	0	0	0
	Sulfate-reducing bacteria		cells/mL	0	0	0	0
	Suspended Solids ^b	(TSS)	ppm	<10	<10	<10	<10
Electrolysis All HX types	Earth Ground Resistance ^x		Ohms		Consult NEC and local electrical codes for grounding requirements		
	Electrolysis Voltage ^d		mV		Measure voltage and internal water loop to HP ground		
	Leakage Current ^d		mA		Measure current in water loop pipe		
Building Primary Electrical Ground to unit, must meet local diameter and penetration length requirements. Do not connect heat pump to steel pipe unless dissimilar materials are separated by using Di-electric unions. Galvanic corrosion of heat pump water pipe will occur							

Water Quality Requirements

1. The ClimateMaster Water Quality Table provides water quality requirements for coaxial and brazed plate heat exchangers.
2. The water must be evaluated by an independent testing facility comparing site samples against this table. When water properties are outside of these parameters, the water must either be treated by a professional water treatment specialist to bring the water quality within the boundaries of this specification, or an external secondary heat exchanger must be used to isolate the heat pump water system from the unsuitable water. Failure to do so will void the warranty of the heat pump system and will limit liability for damage caused by leaks or system failure.
3. Regular sampling, testing and treatment of the water is necessary to assure that the water quality remains within acceptable levels thereby allowing the heat pump to operate at optimum levels.
4. If closed-loop systems are turned off for extended periods, water samples must be tested prior to operating the system.
5. For optimal performance, it is recommended that the closed-loop piping systems are initially filled with de-ionized water.
6. Well water with chemistry outside of these boundaries, and salt water or brackish water requires an external secondary heat exchanger. Surface/Pond water should not be used.
7. If water temperature is expected to fall below 40°F (4.4°C), antifreeze is required. Refer to the heat pump IOM for the correct solution ratios to prevent freezing.
 - α Hydrogen Sulfide has an odor of rotten eggs. If one detects this smell, a test for H₂S must be performed. If H₂S is detected above the limit indicated, remediation is necessary (Consult with your Water Testing/Treatment Professional) or a secondary heat exchanger is required using appropriate materials as recommended by the heat exchanger supplier.
 - β Suspended solids and particulates must be filtered to prevent fouling and failure of heat exchangers. Strainers or particulate filters must be installed to provide a maximum particle size of 600 micron (0.60 mm, 0.023 inch) using a 20 to 30 mesh screen size. When a loop is installed in areas with fine material such as sand or clay, further filtration is required to a maximum of 100 micron. Refer to the Strainer / Filter Sizing Chart to capture the particle sizes encountered on the site.
 - χ The WSHP piping system or other plumbing pipes must not be used as the building ground. An electrical grounding system using a dedicated ground rod meeting NEC and local electrical codes must be installed.
 - δ Refer to the Antifreeze Percentages by Volume table for instructions on measuring resistance and leakage currents within water loops.

Strainer / Filter Sizing

Mesh Size	Particle Size		
	Microns	MM	Inch
20	840	0.840	0.0340
30	533	0.533	0.0210
60	250	0.250	0.0100
100	149	0.149	0.0060
150	100	0.100	0.0040
200	74	0.074	0.0029

ppm = parts per million
ppb = parts per billion

Models:
SZ
024-060

Water Quality Requirements

Measuring Earth Ground Resistance for Ground-Water Applications

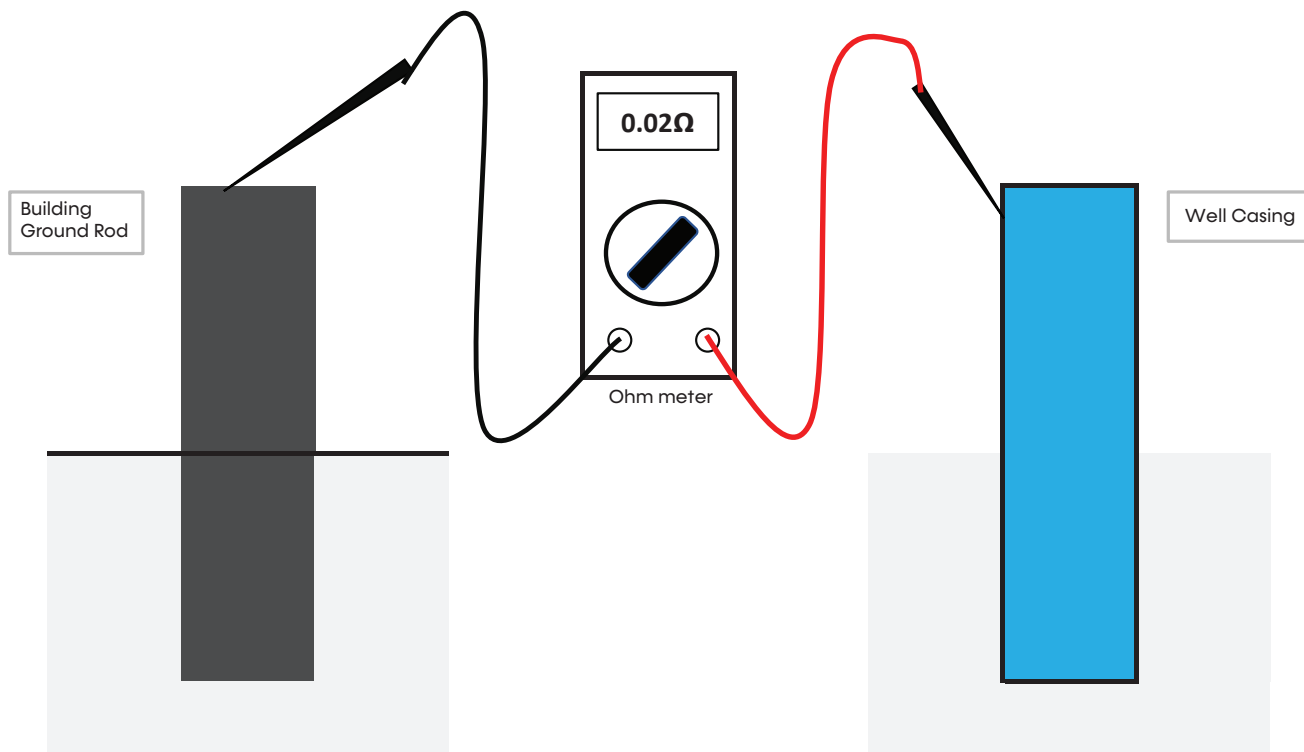

Measure the earth ground bond using an Ohm meter between the building's ground rod and the steel well casing.

The resistance measured should be zero Ohms. The NEC allows a resistance to ground up to 20 Ohms. Any resistance above zero indicates a poor earth ground, which may be the result of a hot neutral line or that conductive water is present. Both of these may lead to electrolysis and corrosion of the heat pump piping. A check for both should be performed and resolved.

NOTE: If the well casing is plastic, a conductive path can be achieved by inserting a #6 AWG bare copper wire into the well water. Remove the temporary conductor when finished.

Water Quality Requirements

Models:
SZ
024-060

Measuring Electrolysis, Voltage, and Current for Ground-Water Applications

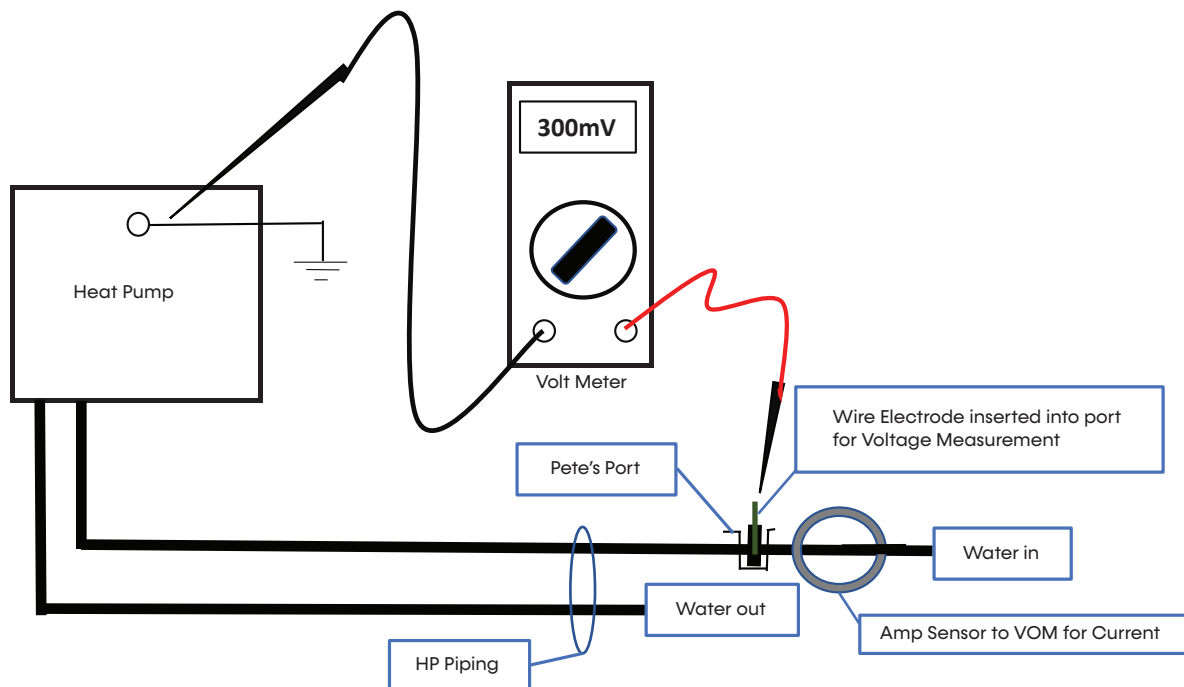

Measure the electrolysis voltage using a volt meter between the heat pump ground and a #14 AWG solid copper wire electrode inserted into the water using a Pete's style access port.

The heat pump must be operating and the water stream flowing.

The voltage measured should be less than 300mV (0.300V). If the voltage is higher than 500mV, electrolysis will occur and corrosion will result.

If voltage is measured, the cause is a high-resistance earth ground or current on the neutral conductor. Remedial measures should be performed.

Measure the current flowing through the piping system by using an amp clamp probe on the water-in line. The heat pump must be operating and the water stream flowing.

Models:
SZ
024-060

Electrical Data: CV EC Blower Motor Standard Unit

Model	Voltage Code	Voltage	Min/Max Voltage	Compressor			Fan Motor FLA	Total Unit FLA	Min Circ Amp	Max Fuse/HACR Amp
				RLA	LRA	Qty				
SZ*024	G.J.	208/230-1-60	197/252	10.3	62.0	1	4.2	14.5	17.1	25
	H.K.	208/230-3-60	197/252	6.3	56.0	1	4.2	10.5	12.1	15
	F.L.	460-3-60*	414/506	3.8	29.0	1	3.4	7.2	8.2	15
SZ*030	G.J.	208/230-1-60	197/252	14.6	82.0	1	4.2	18.8	22.5	30
	H.K.	208/230-3-60	197/252	7.9	66.0	1	4.2	12.1	14.1	20
	F.L.	460-3-60*	414/506	8.0	32.0	1	3.4	11.4	13.4	20
SZ*036	G.J.	208/230-1-60	197/252	14.6	76.0	1	5.9	20.5	24.2	30
	H.K.	208/230-3-60	197/252	8.6	70.0	1	5.9	14.5	16.7	20
	F.L.	460-3-60*	414/506	4.5	39.0	1	4.8	9.3	10.4	15
SZ*042	G.J.	208/230-1-60	197/252	18.2	37.0	1	5.9	24.1	28.7	45
	H.K.	208/230-3-60	197/252	11.5	114.0	1	5.9	17.4	20.3	30
	F.L.	460-3-60*	414/506	6.5	56.0	1	4.8	11.3	12.9	15
SZ*048	G.J.	208/230-1-60	197/252	18.3	138.0	1	5.9	24.2	28.8	45
	H.K.	208/230-3-60	197/252	11.2	112.0	1	5.9	17.1	19.9	30
	F.L.	460-3-60*	414/506	6.8	61.8	1	4.8	11.6	13.3	15
SZ*060	G.J.	208/230-1-60	197/252	22.3	149.0	1	7.5	29.8	35.4	50
	H.K.	208/230-3-60	197/252	14.0	150.0	1	7.5	21.5	25.0	30
	F.L.	460-3-60*	414/506	6.3	58.0	1	6.2	12.5	14.1	15

Notes:

- All fuses Class RK-5.

***NEUTRAL CONNECTION REQUIRED! All F and L voltage (460VAC) units with EC motor require four wire power supply with neutral. EC motor is rated 265VAC and is wired between one hot leg and neutral.**

Electrical Data: CV EC Blower Motor with Internal Secondary Pump

Models:
SZ
024-060

Model	Voltage Code	Voltage	Min/Max Voltage	Compressor			Pump Motor FLA	Fan Motor FLA	Total Unit FLA	Min Circ Amp	Max Fuse/HACR Amp
				RLA	LRA	Qty					
SZ*024	G.J.	208/230-1-60	197/252	10.3	62.0	1	0.8	4.2	15.3	17.9	25
	H.K.	208/230-3-60	197/252	6.3	56.0	1	0.8	4.2	11.3	12.9	15
	F.L.	460-3-60*	414/506	3.8	29.0	1	0.7	3.4	7.9	8.9	15
SZ*030	G.J.	208/230-1-60	197/252	14.6	82.0	1	0.8	4.2	19.6	23.3	30
	H.K.	208/230-3-60	197/252	7.9	66.0	1	0.8	4.2	12.9	14.9	20
	F.L.	460-3-60*	414/506	8.0	32.0	1	0.7	3.4	12.1	14.1	20
SZ*036	G.J.	208/230-1-60	197/252	14.6	76.0	1	0.8	5.9	21.3	25.0	30
	H.K.	208/230-3-60	197/252	8.6	70.0	1	0.8	5.9	15.3	17.5	20
	F.L.	460-3-60*	414/506	4.5	39.0	1	0.7	4.8	10.0	11.1	15
SZ*042	G.J.	208/230-1-60	197/252	18.2	37.0	1	0.8	5.9	24.9	29.5	45
	H.K.	208/230-3-60	197/252	11.5	114.0	1	0.8	5.9	18.2	21.1	30
	F.L.	460-3-60*	414/506	6.5	56.0	1	0.7	4.8	12.0	13.6	15
SZ*048	G.J.	208/230-1-60	197/252	18.3	138.0	1	1.1	5.9	25.3	29.8	45
	H.K.	208/230-3-60	197/252	11.2	112.0	1	1.1	5.9	18.2	21.0	30
	F.L.	460-3-60*	414/506	6.8	61.8	1	1.3	4.8	12.9	14.6	15
SZ*060	G.J.	208/230-1-60	197/252	22.3	149.0	1	1.1	7.5	30.9	36.4	50
	H.K.	208/230-3-60	197/252	14.0	150.0	1	1.1	7.5	22.6	26.1	30
	F.L.	460-3-60*	414/506	6.3	58.0	1	1.3	6.2	13.8	15.4	15

Notes:

- All fuses Class RK-5.

***NEUTRAL CONNECTION REQUIRED! All F and L voltage (460VAC) units with EC motor require four wire power supply with neutral. EC motor is rated 265VAC and is wired between one hot leg and neutral.**

Models:
SZ
024-060

Electrical Data: (CV) Blower Motor EC Standard Unit with Variable Pump

Units with Standard Head Variable Pump

Model	Voltage Code	Voltage	Voltage Min/Max	Compressor			Pump Motor FLA	Fan Motor FLA	Total Unit FLA	Min Circ Amp	Max Fuse/HACR Amp
				RLA	LRA	Qty					
SZ*024	G.J.	208/230-1-60	197/252	10.3	62.0	1	0.64	4.2	15.1	17.7	25
	H.K.	208/230-3-60	197/252	6.3	56.0	1	0.64	4.2	11.1	12.7	15
SZ*030	G.J.	208/230-1-60	197/252	14.6	82.0	1	0.64	4.2	19.4	23.1	30
	H.K.	208/230-3-60	197/252	7.9	66.0	1	0.64	4.2	12.7	14.7	20
SZ*036	G.J.	208/230-1-60	197/252	14.6	76.0	1	0.64	5.9	21.1	24.8	30
	H.K.	208/230-3-60	197/252	8.6	70.0	1	0.64	5.9	15.1	17.3	25
SZ*042	G.J.	208/230-1-60	197/252	18.2	37.0	1	0.64	5.9	24.7	29.3	45
	H.K.	208/230-3-60	197/252	11.5	114.0	1	0.64	5.9	18.0	20.9	30
SZ*048	G.J.	208/230-1-60	197/252	18.3	138.0	1	0.64	5.9	24.8	29.4	45
	H.K.	208/230-3-60	197/252	11.2	112.0	1	0.64	5.9	17.7	20.5	30
SZ*060	G.J.	208/230-1-60	197/252	22.3	149.0	1	0.64	7.5	30.4	36.0	50
	H.K.	208/230-3-60	197/252	14.0	150.0	1	0.64	7.5	22.1	25.6	30

Notes:
• All fuses Class RK-5.

***NEUTRAL CONNECTION REQUIRED! All F and L voltage (460VAC) units with EC motor require four wire power supply with neutral. EC motor is rated 265VAC and is wired between one hot leg and neutral.**

Units with High Head Variable Pump

Model	Voltage Code	Voltage	Min/Max Voltage	Compressor			Pump Motor FLA	Fan Motor FLA	Total Unit FLA	Min Circ Amp	Max Fuse/HACR Amp
				RLA	LRA	Qty					
SZ*024	G.J.	208/230-1-60	197/252	10.3	62.0	1	1.44	4.2	15.9	18.5	25
	H.K.	208/230-3-60	197/252	6.3	56.0	1	1.44	4.2	11.9	13.5	15
SZ*030	G.J.	208/230-1-60	197/252	14.6	82.0	1	1.44	4.2	20.2	23.9	30
	H.K.	208/230-3-60	197/252	7.9	66.0	1	1.44	4.2	13.5	15.5	20
SZ*036	G.J.	208/230-1-60	197/252	14.6	76.0	1	1.44	5.9	21.9	25.6	40
	H.K.	208/230-3-60	197/252	8.6	70.0	1	1.44	5.9	15.9	18.1	25
SZ*042	G.J.	208/230-1-60	197/252	18.2	37.0	1	1.44	5.9	25.5	30.1	45
	H.K.	208/230-3-60	197/252	11.5	114.0	1	1.44	5.9	18.8	21.7	30
SZ*048	G.J.	208/230-1-60	197/252	18.3	138.0	1	1.44	5.9	25.6	30.2	45
	H.K.	208/230-3-60	197/252	11.2	112.0	1	1.44	5.9	18.5	21.3	30
SZ*060	G.J.	208/230-1-60	197/252	22.3	149.0	1	1.44	7.5	31.2	36.8	50
	H.K.	208/230-3-60	197/252	14.0	150.0	1	1.44	7.5	22.9	26.4	40

Notes:
• All fuses Class RK-5.

***NEUTRAL CONNECTION REQUIRED! All F and L voltage (460VAC) units with EC motor require four wire power supply with neutral. EC motor is rated 265VAC and is wired between one hot leg and neutral.**

Electrical: Power Wiring

⚠ WARNING

Disconnect electrical power source to prevent injury or death from electrical shock.

⚠ CAUTION

Use only copper conductors for field installed electrical wiring. Unit terminals are not designed to accept other types of conductors.

ELECTRICAL

Line Voltage - All field installed wiring, including electrical ground, must comply with NFPA 70: National Electrical Code (NEC), CSA C22.1: Canadian Electrical Code (CE Code), as well as applicable local codes. Refer to the unit electrical data for fuse sizes. Consult wiring diagram for field connections that must be made by the installing (or electrical) contractor. All final electrical connections must be made with a length of flexible conduit to minimize vibration and sound transmission to the building

GENERAL LINE VOLTAGE WIRING

Be sure the available power is the same voltage and phase shown on the unit serial plate. Line and low voltage wiring must be done in accordance with local codes or the National Electric Code, whichever is applicable.

Figure 15: Single Phase Line Voltage Field Wiring

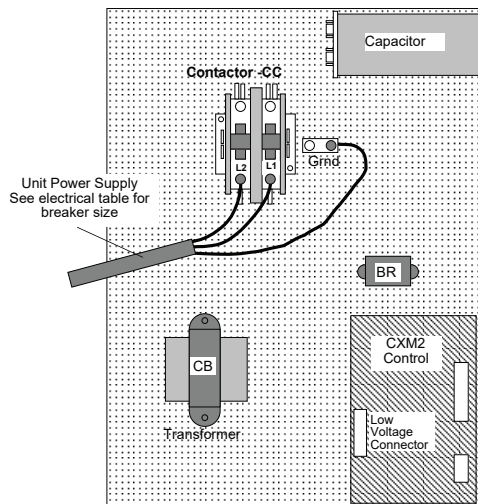

NOTE: 460V units with an EC motor or Internal Secondary Pump require a neutral wire. Three-phase wiring is similar except that all three power wires are directly connected to the contactor.

POWER CONNECTION

Line voltage connection is made by connecting the incoming line voltage wires to the “L” side of the contactor as shown in the unit wiring diagram. Consult electrical data tables for correct fuse size.

TRANSFORMER

All 208/230V units are factory wired for 208V. If supply voltage is 230V, installer must rewire transformer. See wire diagram for connections.

BLOWER SPEED SELECTION

Units with PSC Motor - PSC (Permanent Split Capacitor) blower motor speed can be changed by moving the blue wire on the motor terminal block to the desired speed as shown in the figure below. Most units are shipped on the medium speed tap. Consult submittal data or engineering design guide for specific unit airflow tables. Typical unit design delivers rated airflow at nominal static (0.15 inch w.g. [37 Pa]) on medium speed and rated airflow at a higher static (0.4 to 0.5 in. w.g. [100 to 125 Pa]) on high speed for applications where higher static is required. Low speed will deliver approximately 85% of rated airflow at 0.10 in. w.g. [25 Pa].

Figure 16: PSC Motor Speed Selection

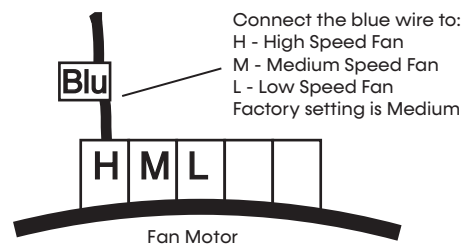

Models:
SZ
024-060

Electrical: DXM2.5 Example Wiring Diagram

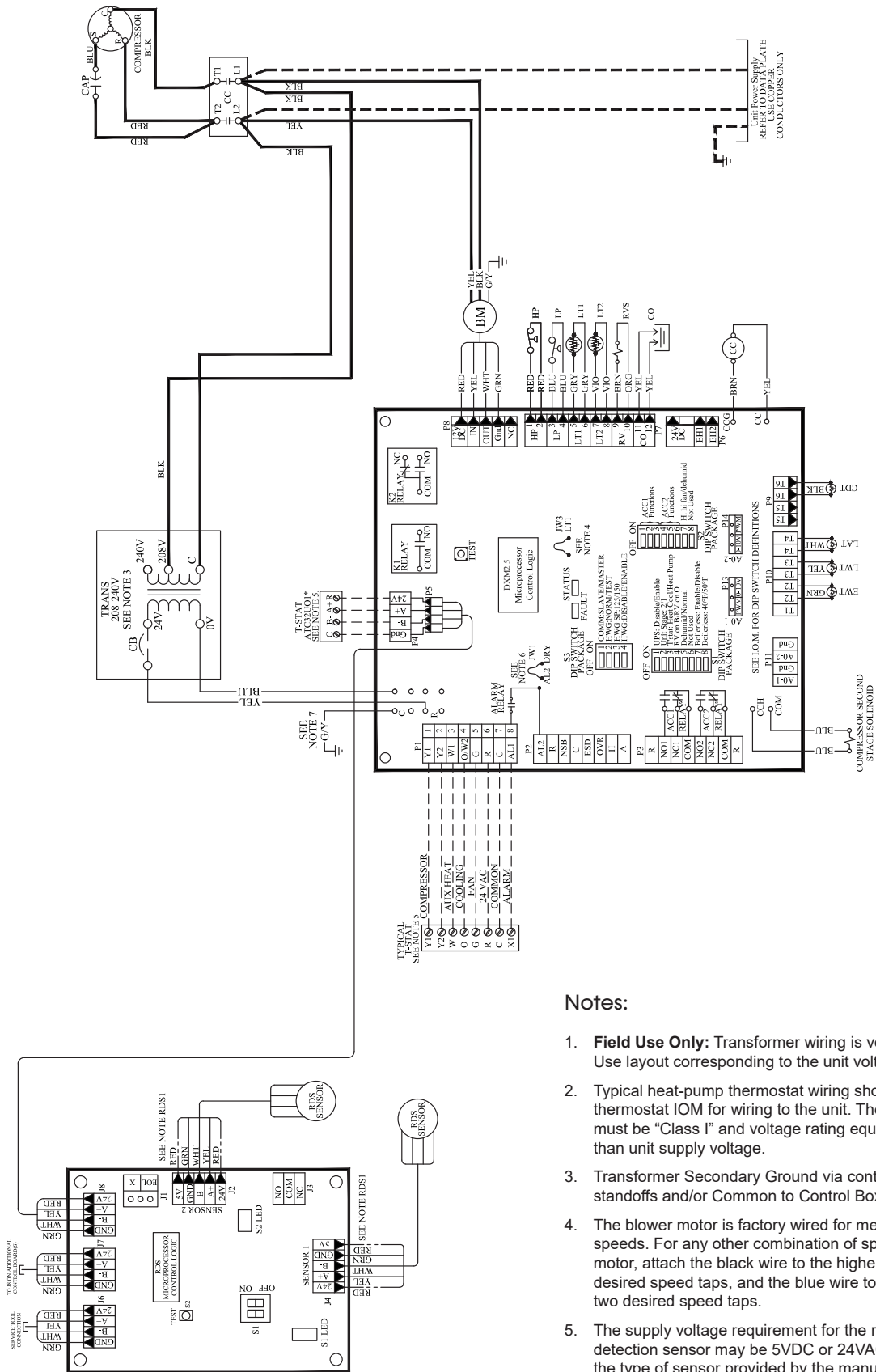

Electrical: Low-Voltage Wiring

THERMOSTAT CONNECTIONS

The thermostat should be wired directly to the DXM2.5 board. See Electrical: Thermostat Wiring for specific terminal connections. Review the appropriate AOM (Application, Operation and Maintenance) manual for units with DDC controls.

LOW WATER TEMPERATURE CUTOUT SELECTION

The DXM2.5 control allows the field selection of low water (or water-antifreeze solution) temperature limit by clipping jumper JW3 (see the figure below), which changes the sensing temperature associated with thermistor LT1. Note that the LT1 thermistor is located on the refrigerant line between the coaxial heat exchanger and expansion device (TXV). Therefore, LT1 is sensing refrigerant temperature, not water temperature, which is a better indication of how water flow rate/temperature is affecting the refrigeration circuit.

The factory setting for LT1 is for systems using water (30°F [-1.1°C] refrigerant temperature). In low water temperature (extended range) applications with antifreeze (most ground loops), jumper JW3 should be clipped as shown in the figure below to change the setting to 10°F [-12.2°C] refrigerant temperature, a more suitable temperature when using an antifreeze solution. All ClimateMaster units operating with entering water temperatures below 60°F [15.6°C] must include the optional water/refrigerant circuit insulation package to prevent internal condensation.

Figure 17: LT1 Limit Setting

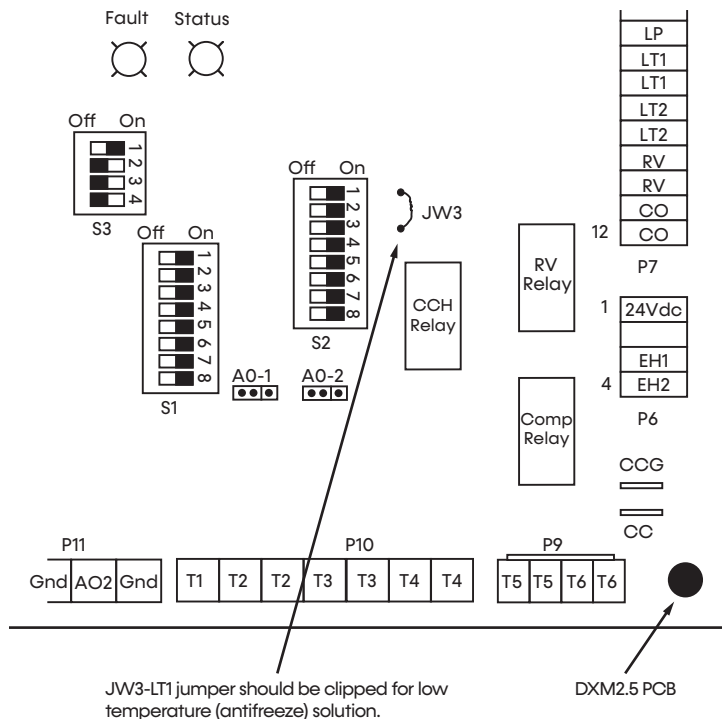

Models:
SZ
024-060

Electrical: Low-Voltage Wiring

ACCESSORY CONNECTIONS

A terminal paralleling the compressor contactor coil has been provided on the DXM2.5 control. Terminal “A” is designed to control accessory devices. **NOTE: This terminal should be used only with 24V signals and not line voltage. Terminal “A” is energized with the compressor contactor.**

The DXM2.5 controller includes two accessory relays ACC1 and ACC2. Each relay includes a normally open (NO) and a normally closed (NC) contact. Accessory relays may be configured to operate as shown in the table below.

Accessory Relay 1 Configuration

DIP 2.1	DIP 2.2	DIP 2.3	ACC1 Relay Option
ON	ON	ON	Cycle with fan
OFF	ON	ON	N/A for Residential Applications
ON	OFF	ON	Water valve – Slow opening
ON	ON	OFF	Outside air damper
OFF	OFF	ON	N/A for Residential Applications
ON	OFF	OFF	N/A for Residential Applications

All other DIP combinations are invalid

Accessory Relay 2 Configuration

DIP 2.4	DIP 2.5	DIP 2.6	ACC2 Relay Option
ON	ON	ON	Cycle with compressor
OFF	ON	ON	N/A for Residential Applications
ON	OFF	ON	Water valve – Slow opening
OFF	OFF	ON	Humidifier
ON	ON	OFF	Outside air damper

All other DIP combinations are invalid

Figure 18: Accessory Wiring

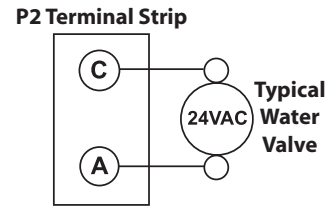

A slow closing valve may be required to help reduce water hammer. Figure 18 shows typical wiring for a 24VAC external solenoid valve. Figure 19 and Figure 20 illustrate typical slow closing water control valve wiring for Taco 500 series (ClimateMaster P/N AVM) and Taco SBV series valves. Slow closing valves take approximately 60 seconds to open (very little water will flow before 45 seconds). Once fully open, an end switch allows the compressor to be energized. Only relay or triac based electronic thermostats should be used with slow closing valves. When wired as shown, the slow closing valve will operate properly with the following notations:

1. The valve will remain open during a unit lockout.
2. The valve will draw approximately 25-35VA through the “Y” signal of the thermostat.

NOTE: This valve can overheat the anticipator of an electromechanical thermostat. Only relay or triac-based thermostats should be used.

Electrical: Low Voltage Wiring for non-vFlow® Units Using External Motorized Water Valve

Models:
SZ
024-060

**Figure 19: Accessory Motorized Water Valve
Typical Wiring Example #1**

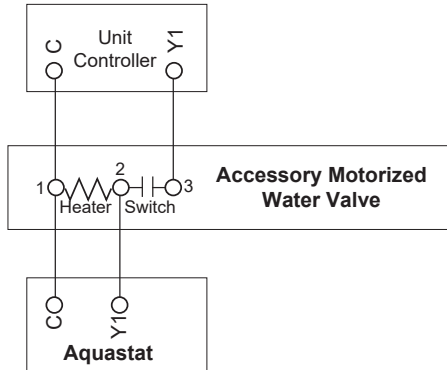
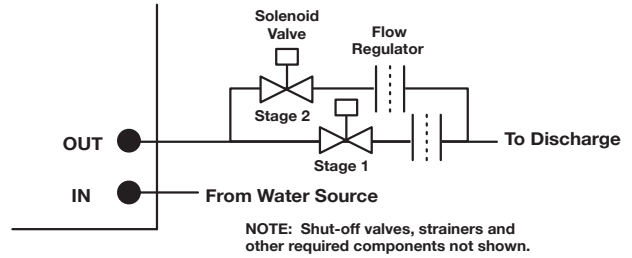
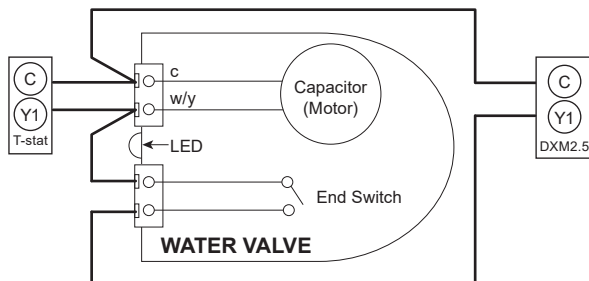

Figure 21: Two-Stage Piping



**Figure 20: Accessory Motorized Water Valve
Typical Wiring Example #2**



Models:
SZ
024-060

Electrical: Low Voltage Wiring

REFRIGERANT DETECTION SYSTEM (RDS)

The function, operation, and required servicing measures for the Refrigerant Detection System (RDS) include the following:

- The RDS monitors the status of the refrigerant sensor(s) in the unit. If refrigerant is detected above the maximum threshold, the control enables the unit blower, disables the compressor(s), and enables the pilot relay on the RDS control board. You can use this relay to open external zoning dampers and/or activate external mechanical ventilation. The relay is normally closed (NC) and can control a signal with a maximum of 28VA @ 24VAC.
- A fault is enabled if the RDS control board loses communication with a refrigerant sensor or if the main control board loses communication with the RDS board. See Functional Troubleshooting for steps to troubleshoot the RDS.

Figure 22: RDS Board

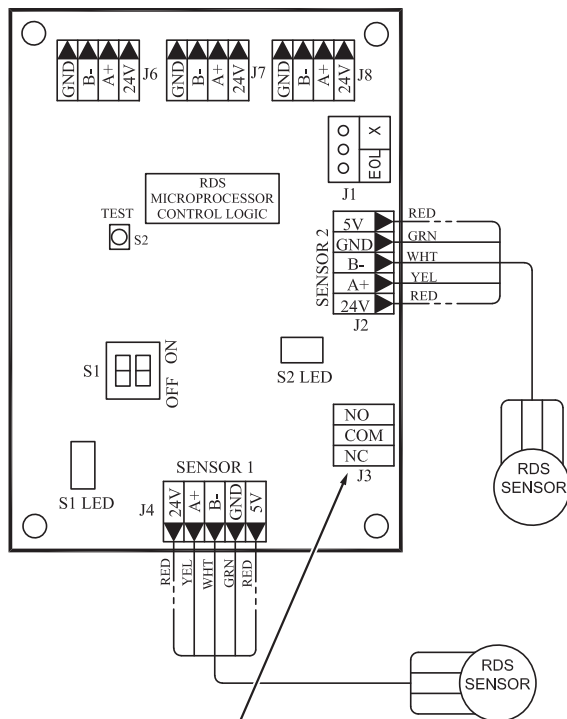

NOTE: Connect mitigation measures to the J3 jumper.

FIELD-INSTALLED RDS SYSTEM

For horizontal systems installed on ceiling plenum for non-ducted applications, use the following guidelines to install a refrigerant detection sensor upstream of the return of the unit:

1. The sensor must be located within 3 inches of the unit
2. The sensor must be on the same plane or lower than the unit
3. The sensor must be on the same side of the coil as the feeder tubes (feeder tubes are located near the electrical components)

NOTICE

The sensor cannot be installed in a way that exposes it to water and must be installed using the orientation displayed in the figure below.

Figure 23: RDS Installation

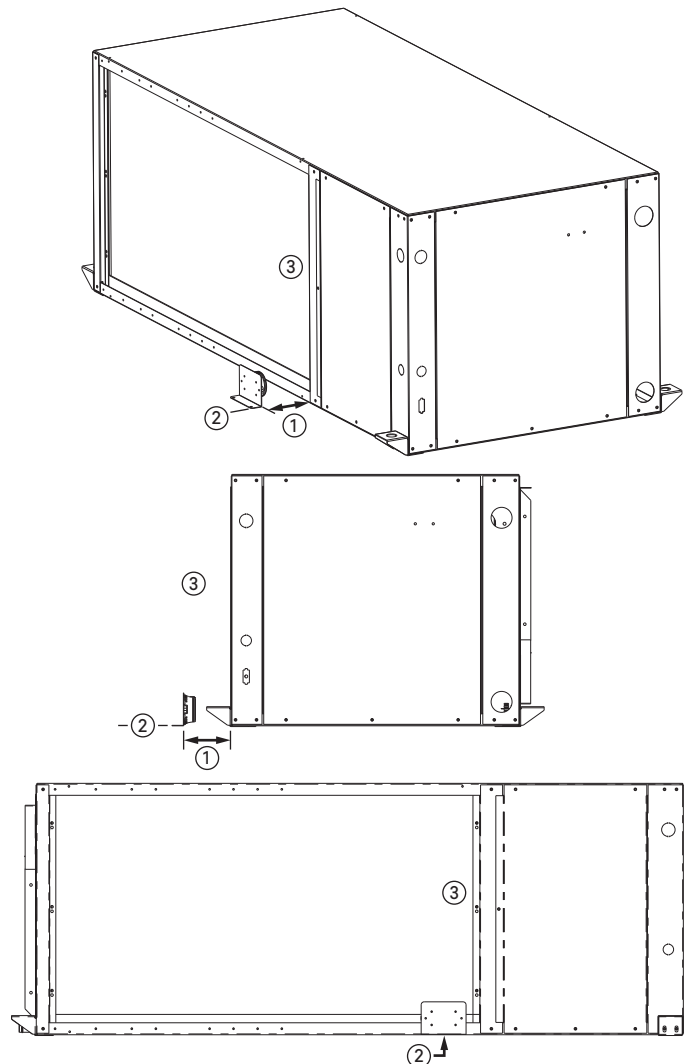

Electrical: Thermostat Wiring

THERMOSTAT INSTALLATION

The thermostat should be located on an interior wall in a larger room, away from supply duct drafts. DO NOT locate the thermostat in areas subject to sunlight, drafts or on external walls. The wire access hole behind the thermostat may, in certain cases, need to be sealed to prevent erroneous temperature measurement.

Position the thermostat back plate against the wall so that it appears level and so the thermostat wires protrude through the middle of the back plate.

Mark the position of the back plate mounting holes and drill holes with a 3/16-inch (5 mm) bit. Install supplied anchors and secure plate to the wall. Thermostat wire must be 18 AWG wire. Representative thermostat wiring is shown in the figures below however, actual wiring connections should be determined from the thermostat IOM and or unit wiring diagram. Practically any heat pump thermostat will work with ClimateMaster units, provided it has the correct number of heating and cooling stages.

Figure 24: Conventional 3 Heat / 2 Cool Thermostat Connection to DXM2.5 Control

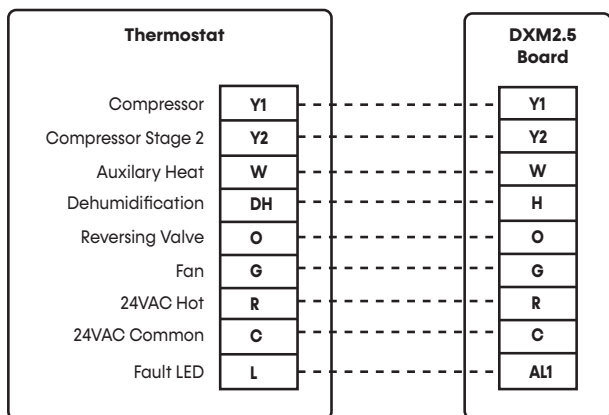
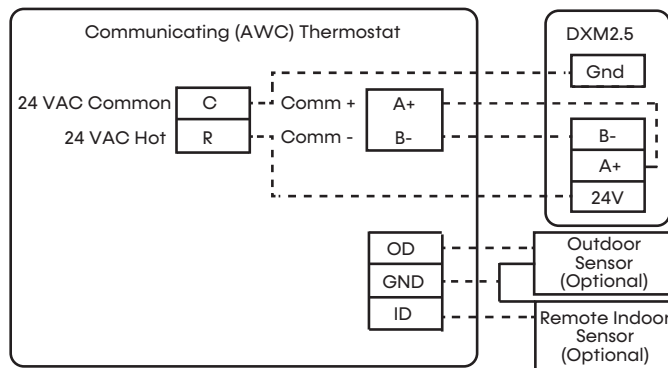

Figure 25: Communicating (AWC) Thermostat Connection to DXM2.5 Control



NOTES:

1. EC automatic dehumidification mode operates with dehumidification airflows in the cooling mode when the dehumidification output from thermostat is active. Normal heating and cooling airflows are not affected.
2. DXM2.5 board DIP switch S2-7 must be in the auto dehumidification mode for automatic dehumidification.
3. DH connection not possible with units with internal variable speed pump. Use Communicating (AWC) Thermostat.
4. Only use Communicating (AWC) Thermostat when using Humidifier (H Input) in units with internal variable speed pump.

Models:
SZ
024-060

Blower Performance Data

CV EC MOTOR ADVANTAGE

A major benefit of the CV EC motor over other blower motor types is its ability to adjust airflow remotely through the iGate 2 web portal/mobile app or directly at the unit with a communicating diagnostic service tool. Airflow levels can be adjusted in increments of 25 CFM from the unit's minimum and maximum CFM range (see the CV EC motor configuration table for details).

Blower Performance: CV EC Blower Motor Standard Unit

Model	Max ESP (in wg)	Fan Motor (hp)	Range	Cooling Mode		Heating Mode		Dehumid Mode		Fan Only Mode	Aux Emergency Mode
				Stg 2	Stg 1	Stg 2	Stg 1	Stg 2	Stg 1		
SZ*024	0.75	1/2	Minimum	600	450	600	450	600	450	300	600
			Default	750	600	750	600	650	500	350	750
			Maximum	850	650	850	650	800	600	850	850
SZ*030	0.5	1/2	Minimum	750	550	750	550	750	550	375	750
			Default	925	750	925	750	800	625	425	925
			Maximum	1050	800	1050	800	1000	750	1050	1050
SZ*036	0.6	3/4	Minimum	900	675	900	675	900	675	450	900
			Default	1125	900	1125	900	975	750	525	1125
			Maximum	1275	975	1275	975	1200	900	1275	1275
SZ*042	0.6	3/4	Minimum	1050	775	1050	775	1050	775	525	1050
			Default	1300	1050	1300	1050	1125	875	600	1300
			Maximum	1475	1125	1475	1125	1400	1050	1475	1475
SZ*048	0.6	3/4	Minimum	1200	900	1200	900	1200	900	600	1200
			Default	1500	1200	1500	1200	1300	1000	700	1500
			Maximum	1700	1300	1700	1300	1600	1200	1700	1700
SZ*060	0.75	1	Minimum	1500	1125	1500	1125	1500	1125	750	1500
			Default	1875	1500	1875	1500	1625	1250	875	1875
			Maximum	2125	1625	2125	1625	2000	1500	2125	2125

Blower performance data is based on the lowest nameplate voltage setting.
Blower performance is based on a wet coil with clean 1-inch filter.
Blower performance is based on operating conditions of 80°F DB and 67°F WB.
CFM Tolerance is ±7%
Cells in grey - option not available

Controls: DXM2.5

Models:
SZ
024-060



DXM2.5 Controls

For detailed controller information, see the DXM2.5 Application, Operation, and Maintenance (AOM) manual (part # 97B0142N01). To confirm the controller type of your particular unit, refer to digit 9 on the

unit model number and the unit nomenclature diagram found on page 3 of this manual.

Models:
SZ
024-060

Operating and Commissioning Limits

OPERATING LIMITS

Environment – Units are designed for indoor installation only. Never install units in areas subject to freezing or where humidity levels could cause cabinet condensation (such as unconditioned spaces subject to 100% outside air).

Power Supply – Voltage utilization shall comply with AHRI Standard 110 or values provided in the electrical data tables.

Determination of operating limits is dependent primarily upon three factors: 1) return air temperature. 2) water temperature, and 3) ambient temperature. When any one of these factors is at minimum or maximum levels, the other two factors should be at normal levels to ensure proper unit operation. Extreme variations in temperature and humidity and/or corrosive water or air will adversely affect unit performance, reliability, and service life.

Table 5: Operating Limits

Operating Limits	Cooling	Heating
Air Limits		
Min. ambient air, DB	*10°F [-12°C]	*10°F [-12°C]
Max. ambient air, DB	130°F [54.4°C]	130°F [54.4°C]
Min. entering air, DB/WB	65/45°F [18/7°C]	50°F [10°C]
Max. entering air, DB/WB	90/72°F [32/22°C]	80°F [27°C]
Min/Max Airflow (CFM/Ton)	**300 to 500 CFM/Ton	
Water Limits		
Min. entering water	***30°F [-1°C]	20°F [-6.7°C]
Max. entering water	120°F [49°C]	90°F [32°C]
Water Flow Range	1.5 to 3.0 gpm/ton [1.6 to 3.2 l/m per kW]****	

Notes:

*To prevent unit damage, the water loop should contain antifreeze to prevent freezing when not in operation.

** Refer to specific blower tables for each model size

***With unit flow-control automation.

**** Unless specified different on performance table for any model size

Unit Maximum Water Working Pressure

Unit Maximum Water Working Pressure	
Options	Max Pressure PSIG [kPa]
Base Unit	500 [3,447]
Internal Secondary Pump (ISP)	145 [999]
Internal Motorized Water Valve (MWV)	300 [2068]
Internal Auto Flow Valve	300 [2068]

COMMISSIONING CONDITIONS

Starting conditions vary depending upon model and are based upon the following notes:

NOTES:

1. Commissioning Conditions are not normal or continuous operating conditions. Minimum/maximum limits are startup conditions to bring the building space up to occupancy temperatures. Units are not designed to operate under these conditions on a regular basis.
2. Voltage utilization range complies with AHRI Standard 110.

Table 6: Commissioning Conditions

Commissioning Conditions	Cooling	Heating
Air Limits		
Min. ambient air, DB	*10°F [-12°C]	*10°F [-12°C]
Max. ambient air, DB	130°F [54.4°C]	130°F [54.4°C]
Min. entering air, DB/WB	65/45°F [18/7°C]	240°F [4.4°C]
Max. entering air, DB/WB	100/75°F [38/24°C]	80°F [27°C]
Min/Max Airflow (CFM/Ton)	**300 to 500 CFM/Ton	
Water Limits		
Min. entering water	***20°F [-6.7°C]	20°F [-6.7°C]
Max. entering water	120°F [49°C]	90°F [32°C]
Water Flow Range	1.5 to 3.0 gpm/ton [1.6 to 3.2 l/m per kW]****	

Notes:

*To prevent unit damage, the water loop should contain antifreeze to prevent freezing when not in operation.

** Refer to specific blower tables for each model size

***With unit flow-control automation.

**** Unless specified different on performance table for any model size

1. Commission units for cooling at entering air temperatures of 100/75°F [38/24°C] only at rated water flow or 3 gpm/ton.
2. Commission units for heating at entering air temperature of 40°F [4.4°C] only at rated water flow or 3 gpm/ton.

Piping System Cleaning and Flushing

PIPING SYSTEM CLEANING AND FLUSHING

Cleaning and flushing the piping system is the single most important step to ensure proper start-up and continued efficient operation of the system.

Use the following instructions to properly clean and flush the system:

1. Ensure that electrical power to the unit is disconnected.
2. Install the system with the supply hose connected directly to the return riser valve. Use a single length of flexible hose.
3. Open all air vents. Fill the system with water. DO NOT allow system to overflow. Bleed all air from the system. Pressurize and check the system for leaks and repair as appropriate.
4. Verify that all strainers are in place (ClimateMaster recommends a strainer with a #20 stainless steel wire mesh). Start the pumps, and systematically check each vent to ensure that all air is bled from the system.
5. Verify that make-up water is available. Adjust make-up water as required to replace the air which was bled from the system. Check and adjust the water/air level in the expansion tank.
6. Set the boiler to raise the loop temperature to approximately 86°F (30°C). Open a drain at the lowest point in the system. Adjust the make-up water replacement rate to equal the rate of bleed.
7. Refill the system and add trisodium phosphate in a proportion of approximately one pound per 150 gallons (.8 kg per 1000 l) of water (or other equivalent approved cleaning agent). Reset the boiler to raise the loop temperature to 100°F (38°C). Circulate the solution for a minimum of 8 to 24 hours. At the end of this period, shut off the circulating pump and drain the solution. Repeat system cleaning if desired.
8. When the cleaning process is complete, remove the short-circuited hoses. Reconnect the hoses to the proper supply, and return the connections to each of the units. Refill the system and bleed off all air.
9. Test the system pH with litmus paper. The system water should be in the range of pH 6.0 - 8.5 (see Table 4). Add chemicals, as appropriate to maintain neutral pH levels.
10. When the system is successfully cleaned, flushed, refilled and bled, check the main system panels, safety cutouts and alarms. Set the controls to properly maintain loop temperatures.

NOTE: The manufacturer strongly recommends all piping connections, both internal and external to the unit, be pressure tested by an appropriate method prior to any finishing of the interior space or before access to all connections is limited. Test pressure may not exceed the maximum allowable pressure for the unit and all components within the water system. The manufacturer will not be responsible or liable for damages from water leaks due to inadequate or lack of a pressurized leak test, or damages caused by exceeding the maximum pressure rating during installation.

Internal Modulating Motorized Valve Positions

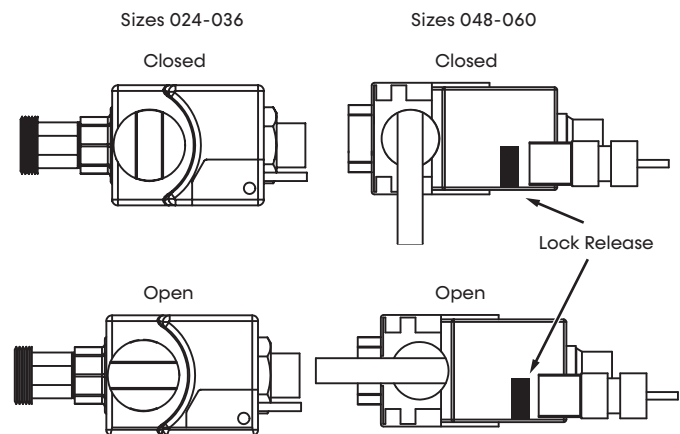

To manually open the internal modulating motorized water valve in SZ024 – 042 push down on the handle to unlock it. Then rotate the handle to the open position as shown in. This fully opens the valve for flushing. Once flushing is complete, return the valve handle to its normally closed position.

To manually open the internal modulating motorized water valve in SZ048 – 060, push down on the lock release button while turning the handle to the open position as shown. This fully opens the valve for flushing. Once flushing is complete, press the lock release again and return the valve handle to its normally closed position.

Models:
SZ
024-060

Unit System Checkout

WARNING

Polyolester Oil, commonly known as POE oil, is a synthetic oil used in many refrigeration systems including those with R-454B refrigerant. POE oil, if it ever comes in contact with PVC or CPVC piping, may cause failure of the PVC/CPVC. PVC/CPVC piping should never be used as supply or return water piping with water source heat pump products containing R-454B as system failures and property damage may result.

UNIT AND SYSTEM CHECKOUT

BEFORE POWERING SYSTEM, please check the following:

UNIT FEATURES

- Balancing/shutoff valves:** Ensure that all isolation valves are open and water control valves are wired.
- Line voltage and wiring:** Verify that voltage is within an acceptable range for the unit and wiring and fuses/breakers are properly sized. Verify that low voltage wiring is complete.
- Unit control transformer:** Ensure that transformer has the properly selected voltage tap.
- Entering water and air:** Ensure that entering water and air temperatures are within operating limits of Table 5 and Table 6.
- Low water temperature cutout:** Verify that low water temperature cut-out on the DXM2.5 control is properly set.
- Unit fan:** Manually rotate fan to verify free rotation and ensure that blower wheel is secured to the motor shaft. Be sure to remove any shipping supports if needed. DO NOT oil motors upon start-up. Fan motors are pre-oiled at the factory. Check unit fan speed selection and compare to design requirements.
- Condensate line:** Verify that condensate line is open and properly pitched toward drain.
- Water flow balancing:** Record inlet and outlet water temperatures for each heat pump upon startup. This check can eliminate nuisance trip outs and high velocity water flow that could erode heat exchangers.
- Unit air coil and filters:** Ensure that filter is clean and accessible. Clean air coil of all manufacturing oils.
- Unit controls:** Verify that DXM2.5 field selection options are properly set.

SYSTEM CHECKOUT

- System water temperature:** Check water temperature for proper range and also verify heating and cooling set points for proper operation.
- System pH:** Check and adjust water pH if necessary to maintain a level between 6 and 8.5. Proper pH promotes longevity of hoses and fittings (see Table 4).
- System flushing:** Verify that all hoses are connected end to end when flushing to ensure that debris bypasses the unit heat exchanger, water valves and other components. Water used in the system must be potable quality initially and clean of dirt, piping slag, and strong chemical cleaning agents. Verify that all air is purged from the system. Air in the system can cause poor operation or system corrosion.
- Cooling tower/boiler:** Check equipment for proper setpoints and operation.
- Standby pumps:** Verify that the standby pump is properly installed and in operating condition.
- System controls:** Verify that system controls function and operate in the proper sequence.
- Low water temperature cutout:** Verify that low water temperature cut-out controls are provided for the outdoor portion of the loop. Otherwise, operating problems may occur.
- System control center:** Verify that the control center and alarm panel have appropriate setpoints and are operating as designed.
- Miscellaneous:** Note any questionable aspects of the installation.

CAUTION

Verify that ALL water control valves are open and allow water flow prior to engaging the compressor. Freezing of the coax or water lines can permanently damage the heat pump.

CAUTION

To avoid equipment damage, DO NOT leave system filled in a building without heat during the winter unless antifreeze is added to the water loop. Heat exchangers never fully drain by themselves and will freeze unless winterized with antifreeze.

Unit Startup Procedure

UNIT STARTUP PROCEDURE

1. Turn the thermostat fan position to "ON". The blower should start.
2. Balance air flow at diffusers.
3. Adjust all valves to their full open positions. Turn on the line power to all heat pumps.
4. Room temperature should be within the minimum-maximum ranges of Table 5 and Table 6. During start-up checks, loop water temperature entering the heat pump should be between 60°F (16°C) and 95°F (35°C).
5. Two factors determine the operating limits of ClimateMaster heat pumps, (a) return air temperature, and (b) water temperature. When any one of these factors is at a minimum or maximum level, the other factor must be at normal level to ensure proper unit operation.
 - a. Adjust the unit thermostat to the warmest setting. Place the thermostat mode switch in the "COOL" position. Slowly reduce thermostat setting until the compressor activates.
 - b. Check for cool air delivery at the unit grille within a few minutes after the unit has begun to operate.

NOTE: Units have a five minute time delay in the control circuit that can be eliminated on the DXM2.5 control board as shown in Figure 26.

- c. Verify that the compressor is on and that the water flow rate is correct by measuring pressure drop through the heat exchanger using the P/T plugs and comparing to Table 7.
- d. Check the elevation and cleanliness of the condensate lines. Dripping may be a sign of a blocked line. Check that the condensate trap is filled to provide a water seal.
- e. Check the temperature of both entering and leaving water. If temperature is within range, proceed with the test. Verify correct water flow by comparing unit pressure drop across the heat exchanger to the data in Table 7.

Heat of rejection (HR) can be calculated and compared to submittal data capacity pages. The formula for HR for systems with water is as follows:

$$\text{HR (Btuh)} = \text{TD} \times \text{GPM} \times 500,$$

where TD is the temperature difference between the entering and leaving water, and GPM is the flow rate in U.S. GPM, determined by comparing the pressure drop across the heat exchanger to Table 7. In S-I units, the formula is as follows:

$$\text{HR (kW)} = \text{TD} \times \text{l/s} \times 4.18.$$

- f. Check air temperature drop across the air coil when compressor is operating. Air temperature drop should be between 15°F and 25°F (8°C and 14°C).
 - g. Turn thermostat to "OFF" position. A hissing noise indicates proper functioning of the reversing valve.
6. Allow five (5) minutes between tests for pressure to equalize before beginning heating test.
 - a. Adjust the thermostat to the lowest setting. Place the thermostat mode switch in the "HEAT" position.
 - b. Slowly raise the thermostat to a higher temperature until the compressor activates.
 - c. Check for warm air delivery within a few minutes after the unit has begun to operate.
 - d. Refer to Table 8. Check the temperature of both entering and leaving water. If temperature is within range, proceed with the test. If temperature is outside of the operating range, check refrigerant pressures. Verify correct water flow by comparing unit pressure drop across the heat exchanger versus the data in Table 7. Heat of extraction (HE) can be calculated and compared to submittal data capacity pages. The formula for HE for systems with water is as follows:

$$\text{HE (kW)} = \text{TD} \times \text{GPM} \times 500$$

Models:
SZ
024-060

Unit Startup Procedure

where TD is the temperature difference between the entering and leaving water, and l/s is the flow rate in U.S. GPM, determined by comparing the pressure drop across the heat exchanger to Table 7. In S-I units, the formula is as follows:

$$HE (kW) = TD \times l/s \times 4.18.$$

- d. Check air temperature rise across the air coil when compressor is operating. Air temperature rise should be between 20°F and 30°F (11°C and 17°C).
 - e. Check for vibration, noise, and water leaks.
7. If unit fails to operate, perform troubleshooting analysis (see Functional Troubleshooting). If the check procedure described fails to reveal the problem, and the unit still does not operate, contact a trained service technician to ensure proper diagnosis and repair of the equipment.
 8. When testing is complete, set system to maintain desired comfort level.

NOTE: If performance during any mode appears abnormal, refer to the DXM2.5 section or troubleshooting section of this manual. To obtain maximum performance, the air coil should be cleaned before startup. A 10% solution of dishwasher detergent and water is recommended.

Figure 26: Test Mode Button

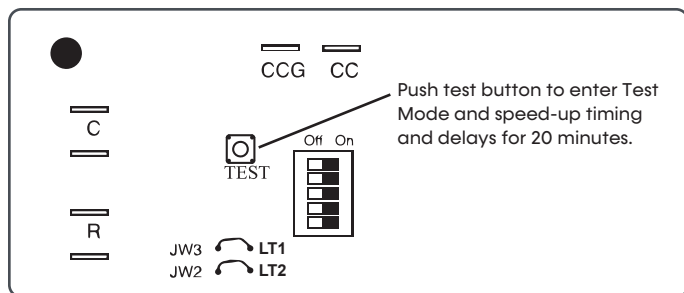

WARNING

When the disconnect switch is closed, high voltage is present in some areas of the electrical panel. Exercise caution when working with energized equipment.

CAUTION

Verify that ALL water control valves are open and allow water flow prior to engaging the compressor. Freezing of the coax or water lines can permanently damage the heat pump.

CAUTION

Many units are installed with a factory or field supplied manual or electric shut-off valve. **DAMAGE WILL OCCUR** if shut-off valve is closed during unit operation. A high pressure switch must be installed on the heat pump side of any field provided shut-off valves and connected to the heat pump controls in series with the built-in refrigerant circuit high pressure switch to disable compressor operation if water pressure exceeds pressure switch setting. The field installed high pressure switch shall have a cut-out pressure of 300 psig and a cut-in pressure of 250 psig.

Unit Operating Conditions

WARNING

When the disconnect switch is closed, high voltage is present in some areas of the electrical panel. Exercise caution when working with energized equipment.

CAUTION

Verify that ALL water control valves are open and allow water flow prior to engaging the compressor. Freezing of the coax or water lines can permanently damage the heat pump.

CAUTION

Many units are installed with a factory or field supplied manual or electric shut-off valve. **DAMAGE WILL OCCUR** if shut-off valve is closed during unit operation. A high pressure switch must be installed on the heat pump side of any field provided shut-off valves and connected to the heat pump controls in series with the built-in refrigerant circuit high pressure switch to disable compressor operation if water pressure exceeds pressure switch setting. The field installed high pressure switch shall have a cut-out pressure of 300 psig and a cut-in pressure of 250 psig.

Table 7: SZ Coax Water Pressure Drop

Model	GPM	Pressure Drop (psi)				
		30°F*	50°F	70°F	90°F	110°F
SZ*024	2.20	0.8	0.5	0.4	0.3	0.3
	3.00	1.3	0.8	0.6	0.6	0.5
	4.50	2.4	1.6	1.3	1.2	1.1
	6.00	3.5	2.5	2.1	2.0	1.8
SZ*030	2.80	1.1	0.6	0.4	0.4	0.3
	3.80	1.8	1.0	0.8	0.7	0.7
	5.60	3.3	2.1	1.7	1.6	1.4
	7.50	4.8	3.3	2.8	2.7	2.5
SZ*036	3.40	1.0	0.7	0.6	0.6	0.6
	4.50	1.6	1.1	1.0	0.9	0.9
	6.80	3.0	2.0	1.7	1.7	1.6
SZ*042	9.00	4.4	3.3	2.8	2.7	2.6
	4.25	0.9	0.8	0.8	0.8	0.7
	5.25	1.4	1.2	1.1	1.1	1.0
	7.90	2.7	2.3	2.1	2.1	1.9
SZ*048	10.50	4.3	3.7	3.5	3.3	3.1
	4.20	0.6	0.6	0.7	0.7	0.5
	6.00	1.4	1.2	1.1	1.0	1.0
	9.00	3.0	2.6	2.3	2.1	2.0
SZ*060	12.00	4.9	4.4	4.0	3.6	3.3
	5.25	1.6	1.3	1.1	1.0	1.0
	7.50	2.6	2.3	2.0	1.9	1.7
	11.25	5.1	4.4	4.0	3.7	3.4
	15.00	8.2	7.2	6.5	6.1	5.6

Models:
SZ
024-060

Unit Operating Conditions

Operating Pressure/Temperature tables include the following notes:

- Airflow is at nominal (rated) conditions
- Entering air is based upon 70°F [21°C] DB in heating and 80/67°F [27/19°C] in cooling
- Subcooling is based upon head pressure at compressor service port
- Cooling air and water values can vary greatly with changes in humidity level

Table 8: SZ Series Typical Unit Operating Pressures and Temperatures

SZ*024		Full Load Cooling - without HWG active						Full Load Heating - without HWG active					
Entering Water Temp °F	Water Flow GPM	Discharge Pressure PSIG	Suction Pressure PSIG	Superheat °F	Subcooling °F	Water Temp Rise °F	Air Temp Drop °F DB	Discharge Pressure PSIG	Suction Pressure PSIG	Superheat °F	Subcooling °F	Water Temp Rise °F	Air Temp Drop °F DB
30*	6	140-160	111-121	22-26	11-15	10-12	18-24	277-297	66-76	8-12	5-9	4-6	17-23
	4.5	147-167	114-124	18-22	11-15	13-15	19-25	274-294	64-74	8-12	5-9	5-7	17-23
	3	161-181	117-127	16-20	14-18	21-23	19-25	270-290	60-70	8-12	5-9	7-9	16-22
50	6	193-213	117-127	14-18	12-16	10-12	19-25	310-330	95-105	9-13	5-9	5-7	23-29
	4.5	202-222	119-129	13-17	14-18	13-15	19-25	307-327	92-102	9-13	6-10	7-9	23-29
	3	221-241	120-130	11-15	16-20	20-22	19-25	301-321	87-97	8-12	6-10	10-12	22-28
70	6	261-281	123-133	9-13	14-18	9-11	18-24	346-366	129-139	10-14	5-9	7-9	30-36
	4.5	273-293	124-134	8-12	16-20	13-15	18-24	342-362	124-134	10-14	5-9	10-12	29-35
	3	296-316	125-135	7-11	19-23	19-21	18-24	333-353	117-127	9-13	6-10	14-16	28-34
90	6	346-366	129-139	6-10	16-20	9-11	18-24	385-405	166-176	12-16	4-8	9-11	37-43
	4.5	359-379	129-139	6-10	17-21	12-14	17-23	379-399	160-170	12-16	4-8	12-14	35-41
	3	385-405	130-140	5-9	21-25	19-21	17-23	367-387	149-159	10-14	5-9	17-19	34-40
120	6	503-523	136-146	6-10	19-23	8-10	15-21						
	4.5	518-538	137-147	5-9	20-24	11-13	15-21						
	3	546-566	138-148	4-8	23-27	18-20	15-21						

*Based on 20% Methanol antifreeze solution

SZ*030		Full Load Cooling - without HWG active						Full Load Heating - without HWG active					
Entering Water Temp °F	Water Flow GPM	Discharge Pressure PSIG	Suction Pressure PSIG	Superheat °F	Subcooling °F	Water Temp Rise °F	Air Temp Drop °F DB	Discharge Pressure PSIG	Suction Pressure PSIG	Superheat °F	Subcooling °F	Water Temp Rise °F	Air Temp Drop °F DB
30*	7.5	145-165	108-118	11-15	7-11	10-12	21-27	302-322	64-74	8-12	7-11	4-6	22-28
	5.6	148-168	110-120	8-12	6-10	13-15	21-27	298-318	61-71	9-13	7-11	5-7	21-27
	3.8	160-180	111-121	6-10	6-10	20-22	21-27	293-313	57-67	8-12	7-11	8-10	20-26
50	7.5	197-217	112-122	7-11	7-11	9-11	20-26	341-361	94-104	8-12	5-9	5-7	28-34
	5.6	205-225	113-123	6-10	7-11	13-15	20-26	337-357	90-100	8-12	5-9	7-9	27-33
	3.8	222-242	113-123	5-9	9-13	19-21	20-26	333-353	85-95	8-12	6-10	10-12	27-33
70	7.5	265-285	116-126	5-9	8-12	9-11	19-25	380-400	126-136	10-14	3-7	6-8	34-40
	5.6	277-297	116-126	5-9	9-13	12-14	19-25	375-395	122-132	10-14	3-7	9-11	33-39
	3.8	298-318	117-127	4-8	11-15	19-21	19-25	369-389	115-125	9-13	4-8	13-15	32-38
90	7.5	349-369	120-130	4-8	8-12	8-10	18-24	417-437	161-171	14-18	2-6	8-10	40-46
	5.6	363-383	120-130	3-7	10-14	12-14	18-24	411-431	155-165	14-18	2-6	10-12	39-45
	3.8	388-408	121-131	3-7	12-16	18-20	18-24	401-421	145-155	13-17	2-6	15-17	37-43
120	7.5	506-526	127-137	3-7	10-14	8-10	16-22						
	5.6	521-541	128-138	2-6	10-14	12-14	16-22						
	3.8	547-567	130-140	1-5	13-17	17-19	16-22						

*Based on 20% Methanol antifreeze solution

Models:
SZ
024-060

Unit Operating Conditions

SZ*036		Full Load Cooling - without HWG active						Full Load Heating - without HWG active					
Entering Water Temp °F	Water Flow GPM	Discharge Pressure PSIG	Suction Pressure PSIG	Superheat °F	Subcooling °F	Water Temp Rise °F	Air Temp Drop °F DB	Discharge Pressure PSIG	Suction Pressure PSIG	Superheat °F	Subcooling °F	Water Temp Rise °F	Air Temp Drop °F DB
30*	9	133-153	111-121	9-13	5-9	10-12	6-12	302-322	64-74	10-14	12-16	4-6	20-26
	6.75	140-160	111-121	7-11	5-9	13-15	19-25	298-318	62-72	10-14	12-16	5-7	19-25
	4.5	155-175	110-120	6-10	12-16	20-22	19-25	293-313	58-68	10-14	12-16	8-10	18-24
50	9	187-207	114-124	7-11	6-10	9-11	-3-3	339-359	94-104	9-13	13-17	5-7	26-32
	6.75	196-216	114-124	5-9	7-11	13-15	18-24	335-355	91-101	9-13	13-17	7-9	25-31
	4.5	215-235	114-124	4-8	12-16	20-22	18-24	329-349	85-95	8-12	14-18	11-13	24-30
70	9	254-274	117-127	5-9	7-11	9-11	-13--7	382-402	129-139	9-13	12-16	7-9	33-39
	6.75	266-286	118-128	4-8	9-13	12-14	18-24	377-397	124-134	9-13	13-17	10-12	32-38
	4.5	288-308	119-129	3-7	11-15	19-21	18-24	367-387	116-126	8-12	13-17	14-16	30-36
90	9	336-356	122-132	3-7	8-12	9-11	-22 - -16	430-450	168-178	11-15	9-13	9-11	40-46
	6.75	349-369	123-133	3-7	10-14	12-14	17-23	422-442	161-171	11-15	10-14	12-14	39-45
	4.5	374-394	124-134	2-6	11-15	18-20	17-23	409-429	150-160	9-13	11-15	18-20	37-43
120	9	486-506	131-141	3-7	7-11	8-10	-37--31						
	6.75	500-520	131-141	2-6	9-13	11-13	15-21						
	4.5	527-547	133-143	1-5	10-14	18-20	16-22						

*Based on 20% Methanol antifreeze solution

SZ*042		Full Load Cooling - without HWG active						Full Load Heating - without HWG active					
Entering Water Temp °F	Water Flow GPM	Discharge Pressure PSIG	Suction Pressure PSIG	Superheat °F	Subcooling °F	Water Temp Rise °F	Air Temp Drop °F DB	Discharge Pressure PSIG	Suction Pressure PSIG	Superheat °F	Subcooling °F	Water Temp Rise °F	Air Temp Drop °F DB
30*	10.5	136-156	93-103	36-40	19-23	9-11	18-24	292-312	62-72	9-13	7-11	3-5	20-26
	7.9	148-168	99-109	34-38	19-23	12-14	18-24	290-310	59-69	9-13	7-11	5-7	19-25
	5.25	163-183	106-116	25-29	19-23	20-22	19-25	285-305	55-65	9-13	7-11	7-9	18-24
50	10.5	186-206	105-115	23-27	16-20	9-11	19-25	322-342	91-101	10-14	7-11	5-7	26-32
	7.9	198-218	108-118	21-25	17-21	13-15	19-25	319-339	88-98	9-13	7-11	7-9	25-31
	5.25	218-238	112-122	16-20	19-23	20-22	19-25	312-332	82-92	9-13	7-11	10-12	24-30
70	10.5	253-273	114-124	13-17	15-19	9-11	19-25	355-375	123-133	12-16	6-10	7-9	32-38
	7.9	266-286	116-126	12-16	17-21	13-15	19-25	351-371	119-129	11-15	6-10	9-11	31-37
	5.25	291-311	117-127	10-14	20-24	20-22	19-25	343-363	111-121	10-14	7-11	13-15	29-35
90	10.5	337-357	121-131	8-12	15-19	10-12	18-24	392-412	157-167	16-20	4-8	8-10	38-44
	7.9	351-371	121-131	7-11	17-21	13-15	19-25	387-407	152-162	15-19	5-9	11-13	38-44
	5.25	380-400	122-132	7-11	21-25	20-22	18-24	376-396	141-151	13-17	5-9	16-18	35-41
120	10.5	496-516	126-136	7-11	18-22	9-11	16-22						
	7.9	513-533	127-137	7-11	21-25	13-15	16-22						
	5.25	545-565	129-139	6-10	25-29	18-20	15-21						

*Based on 20% Methanol antifreeze solution

Models:
SZ
024-060

Unit Operating Conditions

SZ*048		Full Load Cooling - without HWG active						Full Load Heating - without HWG active					
Entering Water Temp °F	Water Flow GPM	Discharge Pressure PSIG	Suction Pressure PSIG	Superheat °F	Subcooling °F	Water Temp Rise °F	Air Temp Drop °F DB	Discharge Pressure PSIG	Suction Pressure PSIG	Superheat °F	Subcooling °F	Water Temp Rise °F	Air Temp Drop °F DB
30*	12	145-165	109-119	18-22	13-17	10-12	19-25	312-332	61-71	1-5	20-24	4-6	18-24
	9	156-176	111-121	15-19	14-18	14-16	19-25	308-328	59-69	2-6	20-24	5-7	18-24
	6	192-212	115-125	13-17	19-23	21-23	19-25	302-322	55-65	-2-2	20-24	8-10	15-9
50	12	193-213	113-123	13-17	14-18	10-12	19-25	347-367	89-99	4-8	19-23	5-7	25-31
	9	205-225	114-124	11-15	16-20	13-15	19-25	342-362	86-96	4-8	19-23	7-9	24-30
	6	231-251	116-126	10-14	19-23	20-22	19-25	340-360	78-88	3-7	20-24	11-13	30-24
70	12	260-280	117-127	10-14	15-19	9-11	18-24	387-407	124-134	7-11	16-20	7-9	31-37
	9	273-293	117-127	9-13	18-22	13-15	19-25	381-401	119-129	6-10	17-21	10-12	30-36
	6	296-316	118-128	9-13	21-25	20-22	19-25	366-386	110-120	6-10	18-22	14-16	47-41
90	12	344-364	121-131	8-12	17-21	9-11	18-24	432-452	164-174	10-14	12-16	9-11	38-44
	9	358-378	121-131	8-12	20-24	13-15	18-24	424-444	157-167	10-14	12-16	12-14	37-43
	6	386-406	121-131	8-12	23-27	19-21	18-24	382-402	152-162	9-13	12-16	15-17	66-60
120	12	503-523	127-137	9-13	19-23	9-11	16-22						
	9	521-541	128-138	9-13	23-27	12-14	16-22						
	6	570-590	131-141	7-11	28-32	18-20	16-22						

*Based on 20% Methanol antifreeze solution

SZ*060		Full Load Cooling - without HWG active						Full Load Heating - without HWG active					
Entering Water Temp °F	Water Flow GPM	Discharge Pressure PSIG	Suction Pressure PSIG	Superheat °F	Subcooling °F	Water Temp Rise °F	Air Temp Drop °F DB	Discharge Pressure PSIG	Suction Pressure PSIG	Superheat °F	Subcooling °F	Water Temp Rise °F	Air Temp Drop °F DB
30*	15	140-160	105-115	25-29	12-16	9-11	19-25	283-303	61-71	4-8	5-9	5-7	11-17
	11.25	148-168	106-116	20-24	14-18	13-15	19-25	286-306	64-74	4-8	5-9	3-5	20-26
	7.5	161-181	108-118	17-21	15-19	20-22	19-25	279-299	57-67	4-8	9-13	7-9	18-24
50	15	188-208	113-123	16-20	12-16	9-11	19-25	315-335	89-99	4-8	4-8	7-9	12-18
	11.25	198-218	114-124	13-17	14-18	13-15	19-25	318-338	93-103	5-9	4-8	5-7	26-32
	7.5	217-237	115-125	11-15	18-22	20-22	19-25	309-329	84-94	4-8	11-15	10-12	24-30
70	15	253-273	120-130	9-13	13-17	9-11	18-24	349-369	122-132	7-11	3-7	9-11	13-19
	11.25	265-285	120-130	9-13	15-19	13-15	18-24	353-373	126-136	8-12	3-7	7-9	32-38
	7.5	289-309	121-131	7-11	20-24	19-21	18-24	341-361	114-124	6-10	13-17	13-15	30-36
90	15	335-355	126-136	6-10	14-18	9-11	17-23	386-406	157-167	13-17	2-6	11-13	13-19
	11.25	348-368	126-136	6-10	16-20	13-15	18-24	391-411	163-173	14-18	2-6	8-10	39-45
	7.5	376-396	127-137	5-9	21-25	19-21	18-24	376-396	148-158	10-14	15-19	16-18	36-42
120	15	490-510	132-142	6-10	15-19	8-10	15-21						
	11.25	506-526	132-142	6-10	18-22	12-14	16-22						
	7.5	535-555	133-143	6-10	21-25	18-20	16-22						

*Based on 20% Methanol antifreeze solution

Preventative Maintenance

WATER COIL MAINTENANCE (WATER LOOP APPLICATIONS)

Generally water coil maintenance is not needed for closed loop systems. However, if the piping is known to have high dirt or debris content, it is best to establish a periodic maintenance schedule with the owner so the water coil can be checked regularly. Dirty installations are typically the result of deterioration of iron or galvanized piping or components in the system. Open cooling towers requiring heavy chemical treatment and mineral buildup through water use can also contribute to higher maintenance. Should periodic coil cleaning be necessary, use standard coil cleaning procedures, which are compatible with both the heat exchanger material and copper water lines. Generally, the more water flowing through the unit, the less chance for scaling. However, flow rates over 3 gpm per ton (3.9 l/m per kW) can produce water (or debris) velocities that can erode the heat exchanger wall and ultimately produce leaks.

HOT WATER GENERATOR COILS

See water coil maintenance for ground water units. If the potable water is hard or not chemically softened, the high temperatures of the desuperheater will tend to scale even quicker than the water coil and may need more frequent inspections. In areas with extremely hard water, a HWG is not recommended.

FILTERS

Filters must be clean to obtain maximum performance. Filters should be inspected every month under normal operating conditions and be replaced when necessary. Units should never be operated without a filter.

CONDENSATE DRAIN

In areas where airborne bacteria may produce a “slimy” substance in the drain pan, it may be necessary to treat the drain pan chemically with an algacide approximately every three months to minimize the problem. The condensate pan may also need to be cleaned periodically to ensure indoor air quality. The condensate drain can pick up lint and dirt, especially with dirty filters. Inspect the drain twice a year to avoid the possibility of plugging and eventual overflow.

COMPRESSOR

Conduct annual amperage checks to ensure that amp draw is no more than 10% greater than indicated on the serial dataplate.

AIR COIL

The air coil must be cleaned to obtain maximum performance. Check once a year under normal operating conditions and, if dirty, brush or vacuum clean. Care must be taken not to damage the aluminum fins while cleaning.

CAUTION: Fin edges are sharp and may cause injury.

CABINET

Do not allow water to stay in contact with the cabinet for long periods of time to prevent corrosion of the cabinet sheet metal. Generally, vertical cabinets are set up from the floor a few inches (7 - 8 cm) to prevent water from entering the cabinet. The cabinet can be cleaned using a mild detergent.

REPAIRS TO SEALED COMPONENTS

Sealed electrical components shall be replaced.

Models:
SZ
024-060

Troubleshooting

GENERAL

If operational difficulties are encountered, perform the preliminary checks below before referring to the troubleshooting charts.

- Verify that the unit is receiving electrical supply power
- Make sure the fuses in the fused disconnect switches are intact

After completing the preliminary checks described above, inspect for other obvious problems such as leaking connections, broken or disconnected wires, etc. If everything appears to be in order, but the unit still fails to operate properly, refer to the “DXM2.5 Troubleshooting Process Flowchart” or “Functional Troubleshooting Chart.”

DXM2.5 BOARD

DXM2.5 board troubleshooting in general is best summarized as verifying inputs and outputs. After inputs and outputs have been verified, board operation is confirmed and the problem must be elsewhere. Below are some general guidelines for troubleshooting the DXM2.5 control.

FIELD INPUTS

Conventional thermostat inputs are 24VAC from the thermostat and can be verified using a voltmeter between C and Y1, Y2, W, O, G. 24VAC will be present at the terminal (for example, between “Y1” and “C”) if the thermostat is sending an input to the DXM2.5 board.

Proper communications with a thermostat can be verified using the Fault LED on the DXM2.5. If the control is NOT in the Test mode and is NOT currently locked out or in a retry delay, the Fault LED on the DXM2.5 will flash very slowly (1 second on, 5 seconds off), if the DXM2.5 is properly communicating with the thermostat.

SENSOR INPUTS

All sensor inputs are ‘paired wires’ connecting each component to the board. Therefore, continuity on pressure switches, for example can be checked at the board connector. The thermistor resistance should be measured with the connector removed so that only the impedance of the thermistor is measured.

OUTPUTS

The compressor and reversing valve relays are 24VAC and can be verified using a voltmeter. For units with EC blower motors, the DXM2.5 controls the motor using serial communications, and troubleshooting should be done with a communicating thermostat or diagnostic tool. The alarm relay can either be 24VAC as shipped or dry contacts for use with DDC controls by clipping the JW1 jumper. Electric heat outputs are 24VDC “ground sinking” and require a voltmeter set for DC to verify operation. The terminal marked “24VDC” is the 24VDC supply to the electric heat board; terminal “EH1” is stage 1 electric heat; terminal “EH2” is stage 2 electric heat. When electric heat is energized (thermostat is sending a “W” input to the DXM2.5 controller), there will be 24VDC between terminal “24VDC” and “EH1” (stage 1 electric heat) and/or “EH2” (stage 2 electric heat). A reading of 0VDC between “24VDC” and “EH1” or “EH2” will indicate that the DXM2.5 board is NOT sending an output signal to the electric heat board.

TEST MODE

Test mode can be entered for 20 minutes by pressing the Test pushbutton. The DXM2.5 board automatically exits test mode after 20 minutes.

WARNING

HAZARDOUS VOLTAGE! DISCONNECT ALL ELECTRIC POWER INCLUDING REMOTE DISCONNECTS BEFORE SERVICING.

Failure to disconnect power before servicing can cause severe personal injury or death.

ADVANCED DIAGNOSTICS

If a communicating thermostat or diagnostic tool (ACDU) is connected to the DXM2.5, additional diagnostic information and troubleshooting capabilities are available. The current status of all DXM2.5 inputs can be verified, including the current temperature readings of all temperature inputs. With a communicating thermostat, the current status of the inputs can be accessed from the Service Information menu. In the manual operating mode, most DXM2.5 outputs can be directly controlled for system troubleshooting. With a communicating thermostat, the manual operating mode can be accessed from the Installer menu. For more detailed information on the advanced diagnostics of the DXM2.5, see the DXM2.5 Application, Operation and Maintenance (AOM) manual (part #97B0142N01).

DXM2.5 TROUBLESHOOTING PROCESS FLOWCHART/FUNCTIONAL TROUBLESHOOTING CHART

The DXM2.5 Functional Troubleshooting Process Flowchart is a quick overview of how to start diagnosing a suspected problem using the fault recognition features of the DXM2.5 board. The Functional Troubleshooting Chart on the following page is a more comprehensive method for identifying a number of malfunctions that may occur and is not limited to just the DXM2.5 controls. Within the chart are five columns:

- The Fault column describes the symptoms.
- Columns 2 and 3 identify in which mode the fault is likely to occur, heating or cooling.
- The “Possible Cause column” identifies the most likely sources of the problem.
- The “Solution” column describes what should be done to correct the problem.

Models:
SZ
024-060

DXM2.5 Functional Troubleshooting Flow Chart

⚠ WARNING
HAZARDOUS VOLTAGE! DISCONNECT ALL ELECTRIC POWER INCLUDING REMOTE DISCONNECTS BEFORE SERVICING.
Failure to disconnect power before servicing can cause severe personal injury or death.

DXM2.5 Functional Troubleshooting Flow Chart

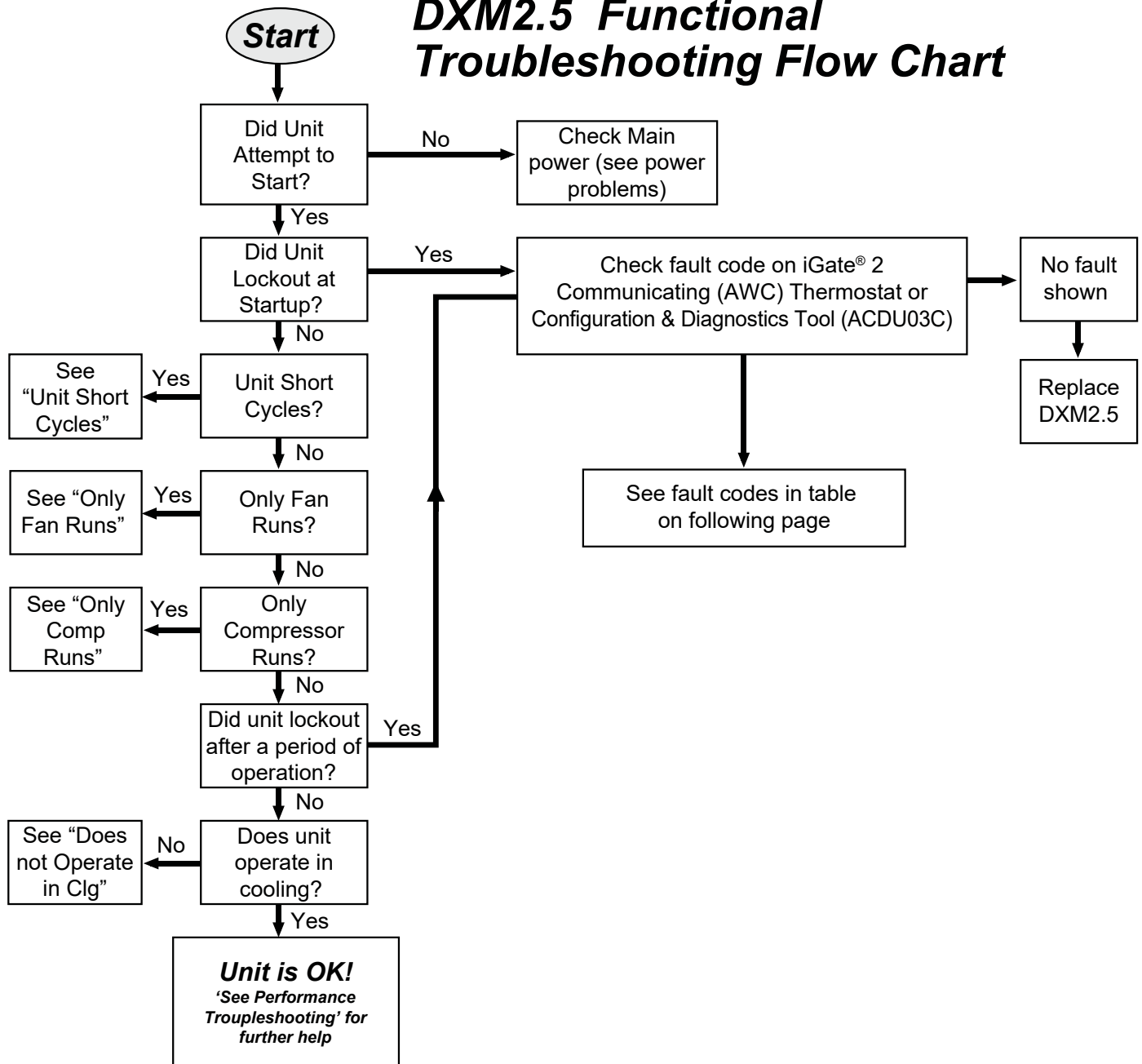

Functional Troubleshooting

Fault	Htg	Clg	Possible Cause	Solution
Main power problems	X	X	Green Status LED Off	Check line voltage circuit breaker and disconnect.
				Check for line voltage between L1 and L2 on the contactor.
				Check for 24VAC between R and C on CXM2/DXM2.5.
				Check primary/secondary voltage on transformer.
HP Fault Code 2 High Pressure		X	Reduced or no water flow in cooling	Check pump operation or valve operation/setting. Check water flow adjust to proper flow rate.
		X	Water Temperature out of range in cooling	Bring water temp within design parameters.
	X		Reduced or no airflow in heating	Check for dirty air filter and clean or replace.
				Check fan motor operation and airflow restrictions.
				Dirty Air Coil - construction dust etc.
				Too high of external static? Check static vs blower table.
	X		Air temperature out of range in heating	Bring return air temp within design parameters.
	X	X	Overcharged with refrigerant	Check superheat/subcooling vs typical operating condition table.
X	X	Bad HP Switch	Check switch continuity and operation. Replace.	
LP/LOC Fault Code 3 Low Pressure / Loss of Charge	X	X	Insufficient charge	Check for refrigerant leaks.
	X		Compressor pump down at startup	Check charge and startup water flow.
LT1 Fault Code 4 Water coil low- temperature limit	X		Reduced or no water flow in heating	Check pump operation or water valve operation/setting.
				Plugged strainer or filter? Clean or replace.
				Check water flow. Adjust to proper flow rate.
	X		Inadequate antifreeze level	Check antifreeze density with hydrometer.
	X		Improper temperature limit setting (30°F vs 10°F [-1°C vs -2°C])	Clip JW3 jumper for antifreeze (10°F [-12°C]) use.
	X		Water Temperature out of range	Bring water temp within design parameters.
X	X	Bad thermistor	Check temp and impedance correlation per chart.	
LT2 Fault Code 5 Air coil low-temperature limit		X	Reduced or no airflow in cooling	Check for dirty air filter and clean or replace. Check fan motor operation and airflow restrictions. Too high of external static? Check static vs blower table.
		X	Air Temperature out of range	Too much cold vent air? Bring entering air temp within design parameters.
		X	Improper temperature limit setting (30°F vs 10°F [-1°C vs -12°C])	Normal airside applications will require 30°F [-1°C] only.
	X	X	Bad thermistor	Check temp and impedance correlation per chart.
	Condensate Fault Code 6	X	X	Blocked drain
X		X	Improper trap	Check trap dimensions and location ahead of vent.
		X	Poor drainage	Check for piping slope away from unit. Check slope of unit toward outlet. Poor venting? Check vent location.
		X	Moisture on sensor	Check for moisture shorting to air coil.
X		X	Plugged air filter	Replace air filter.
X		X	Restricted Return Airflow	Find and eliminate restriction. Increase return duct and/or grille size.

Table continued on next page

Models:
SZ
024-060

Functional Troubleshooting

Table continued from previous page

Fault	Htg	Cig	Possible Cause	Solution
Over/Under Voltage Code 7 (Auto resetting)	X	X	Under Voltage	Check power supply and 24VAC voltage before and during operation.
				Check power supply wire size.
	X	X	Over Voltage	Check compressor starting. Need hard start kit?
				Check 24VAC and unit transformer. Tap for correct power supply voltage.
Unit Performance Sentinel Code 8	X	X	Heating mode LT2>125°F [52°C]	Check power supply voltage and 24VAC before and during operation.
			Cooling Mode LT1>125°F [52°C] OR LT2< 40°F [4°C]	Check 24VAC and unit transformer. Tap for correct power supply voltage.
Swapped Thermistor Code 9	X	X	LT1 and LT2 swapped	Check for poor airflow or overcharged unit.
Low Water Flow Code 13	X	X	Reduced or no water flow	Check for poor airflow or overcharged unit.
				Check pump or valve operation setting.
				Check water flow and adjust to proper flow rate.
	X		Inadequate antifreeze level	Clogged Y strainer, replace mesh.
	X	X	Bad flow switch	Check antifreeze density with hydrometer.
Leaving Water Temperature Low Code 14	X		Reduced or no water flow in heating	Confirm applied flow to looks vs minimum flow switch setpoint on label.
				Check pump or valve operation setting.
	X		Inadequate antifreeze level	Check water flow and adjust to proper flow rate.
				Check antifreeze density with hydrometer.
				Improper temperature limit setting (30°F vs 15°F [-1°C vs -9°C])
X		Water temperature out of range	Bring water temperature within design parameters.	
X	X	Bad thermistor	Check temperature impedance correlation per chart.	
Refrigerant and RDS Code 15	X	X	Refrigerant Leak	Check refrigerant charge. If the charge is low, identify and repair the leak.
			Faulty RDS sensor	Check refrigerant charge. If the charge is not low, replace the RDS sensor.
No Fault Code Shown	X	X	No compressor operation	See "Only Fan Operates".
	X	X	Compressor overload	Check and replace, if necessary.
	X	X	Control board	Reset power and check operation.
Unit Short Cycles	X	X	Dirty air filter	Check and clean air filter.
	X	X	Unit in "test mode"	Reset power or wait 20 minutes for auto exit.
	X	X	Unit selection	Unit may be oversized for space. Check sizing for actual load of space.
	X	X	Compressor overload	Check and replace, if necessary.
Only Fan Runs	X	X	Thermostat position	Ensure thermostat set for heating or cooling operation.
	X	X	Unit locked out	Check for lockout codes. Reset power.
	X	X	Compressor Overload	Check compressor overload. Replace if necessary.
	X	X	Thermostat wiring	Check thermostat wiring at heat pump. Jumper Y and R for compressor operation in test mode.

Table continued on next page

Functional Troubleshooting

Models:
SZ
024-060

Table continued from previous page

Fault	Htg	Clg	Possible Cause	Solution
Only Compressor Runs	X	X	Thermostat wiring	Check G wiring at heat pump. Jumper G and R for fan operation.
	X	X		Check thermostat wiring at heat pump. Jumper Y and R for compressor operation in test mode.
	X	X	Fan motor relay	Jumper G and R for fan operation. Check for line voltage across BR contacts.
	X	X		Check fan power enable relay operation (if present).
	X	X	Fan motor	Check for line voltage at motor. Check capacitor.
Unit Doesn't Operate in Cooling		X	Reversing valve	Set for cooling demand and check 24VAC on RV coil and at CXM2/DXM2.5 board.
		X		If RV is stuck, run high pressure up by reducing water flow and while operating engage and disengage RV coil voltage to push valve.
		X	Thermostat setup	Check for 'O' RV setup not 'B'.
		X	Thermostat wiring	Check O wiring at heat pump. Jumper O and R for RV coil 'click'.
		X		Put thermostat in cooling mode. Check 24VAC on O (check between C and O); check for 24VAC on W (check between W and C). There should be voltage on O, but not on W. If voltage is present on W, thermostat may be bad or wired incorrectly.

Models:
SZ
024-060

Performance Troubleshooting

Symptom	Htg	Cig	Possible Cause	Solution
Insufficient capacity/ Not cooling or heating properly	X	X	Dirty filter	Replace or clean.
	X		Reduced or no airflow in heating	Check for dirty air filter and clean or replace.
				Check fan motor operation and airflow restrictions.
				Too high of external static? Check static vs. blower table.
		X	Reduced or no airflow in cooling	Check for dirty air filter and clean or replace.
				Check fan motor operation and airflow restrictions.
				Too high of external static? Check static vs. blower table.
	X	X	Leaky duct work	Check supply and return air temperatures at the unit and at distant duct registers. If significantly different, duct leaks are present.
	X	X	Low refrigerant charge	Check superheat and subcooling per chart.
	X	X	Restricted metering device	Check superheat and subcooling per chart. Replace.
		X	Defective reversing valve	Perform RV touch test.
	X	X	Thermostat improperly located	Check location and for air drafts behind stat.
X	X	Unit undersized	Recheck loads & sizing. Check sensible cooling load and heat pump capacity.	
X	X	Scaling in water heat exchanger	Perform scaling check and clean if necessary.	
X	X	Inlet water too hot or cold	Check load, loop sizing, loop backfill, ground moisture.	
High Head Pressure	X		Reduced or no airflow in heating	Check for dirty air filter and clean or replace.
				Check fan motor operation and airflow restrictions.
				Too high of external static? Check static vs. blower table.
		X	Reduced or no water flow in cooling	Check pump operation or valve operation/setting.
				Check water flow. Adjust to proper flow rate.
		X	Inlet water too hot	Check load, loop sizing, loop backfill, ground moisture.
	X		Air temperature out of range in heating	Bring return air temperature within design parameters.
		X	Scaling in water heat exchanger	Perform scaling check and clean if necessary.
	X	X	Unit overcharged	Check superheat and subcooling. Re-weigh in charge.
X	X	Non-condensables in system	Vacuum system and re-weigh in charge.	
X	X	Restricted metering device	Check superheat and subcooling per chart. Replace.	
Low Suction Pressure	X		Reduced water flow in heating	Check pump operation or water valve operation/setting.
				Plugged strainer or filter? Clean or replace.
				Check water flow. Adjust to proper flow rate.
	X		Water temperature out of range	Bring water temperature within design parameters.
		X	Reduced airflow in cooling	Check for dirty air filter and clean or replace.
				Check fan motor operation and airflow restrictions.
			Too high of external static? Check static vs. blower table.	
	X	Air temperature out of range	Too much cold vent air? Bring entering air temperature within design parameters.	
X	X	Insufficient charge	Check for refrigerant leaks.	
Low Discharge Air Temperature in Heating	X		Too high of airflow	Check fan motor speed selection and airflow chart.
	X		Poor performance	See 'Insufficient Capacity'
High humidity		X	Too high of airflow	Check fan motor speed selection and airflow chart.
		X	Unit oversized	Recheck loads & sizing. Check sensible cooling load and heat pump capacity.

Table continued on next page

Performance Troubleshooting

Table continued from previous page

Symptom	Htg	Clg	Possible Cause	Solution
Only Compressor Runs	X	X	Thermostat wiring	Check G wiring at heat pump. Jumper G and R for fan operation.
	X	X	Fan motor relay	Jumper G and R for fan operation. Check for line voltage across blower relay contacts. Check fan power. Enable relay operation (if present).
	X	X	Fan motor	Check for line voltage at motor. Check capacitor.
	X	X	Thermostat wiring	Check thermostat wiring at DXM2.5. Put in Test Mode and then jumper Y1 and W1 to R to give call for fan, compressor and electric heat.
Unit Doesn't Operate in Cooling		X	Reversing valve	Set for cooling demand and check 24VAC on RV coil. If RV is stuck, run high pressure up by reducing water flow and, while operating, engage and disengage RV coil voltage to push valve.
		X	Thermostat setup	For DXM2.5, check for "O" RV setup, not "B".
		X	Thermostat wiring	Check O wiring at heat pump. DXM2.5 requires call for compressor. To get RV coil, "Click".
Modulating Valve Troubleshooting	X	X	Improper output setting	Verify the AO-2 jumper is in the 0-10V position.
	X	X	No valve output signal	Check DC voltage between AO2 and GND. Should be 0 when valve is off and between 3.3v and 10v when valve is on. Check voltage to the valve.
	X	X	No valve operation	Replace valve if voltage and control signals are present at the valve and it does not operate.

Models:
SZ
024-060

Startup Log Sheet

7300 S.W. 44th Street, Oklahoma City, OK 73179 • Phone: 1-800-299-9747

Installer: Complete *Unit and System Checkout* and follow *Unit Startup Procedures* in the IOM. Use this form to record unit information, temperatures, and pressures during startup. Keep this form for reference.

Job Name: _____

Street Address: _____

Model Number: _____

Serial Number: _____

Unit Location in Building: _____

Date: _____

Sales Order Number: _____

In order to minimize troubleshooting and costly system failures, complete the following checks and data entries before the system is put into full operation.

Fan Motor	Description	Value
CV EC	CFM Setting	

Temperatures (check one): °F °C Antifreeze: _____ %

Pressures (check one): PSIG kPa Type: _____

	Cooling Mode		Heating Mode	
Entering Fluid Temperature				
Leaving Fluid Temperature				
Fluid Temperature Differential				
Return-Air Temperature	DB	WB		DB
Supply-Air Temperature	DB	WB		DB
Air Temperature Differential				
Water Coil Heat Exchanger (Water Pressure IN)				
Water Coil Heat Exchanger (Water Pressure OUT)				
Pressure Differential				
Flow Rate GPM (l/s)				
Compressor				
Amps				
Volts				
Discharge Line Temperature				
Motor				
Amps				
Volts				

NOTES:

1. Allow unit to run 15 minutes in each mode before taking data.
2. Never connect refrigerant gauges during startup procedures.
3. Conduct water-side analysis using P/T ports to determine water flow and temperature difference.
4. If water-side analysis shows poor performance, refrigerant troubleshooting may be required.
5. Connect refrigerant gauges as a last resort.

Functional Troubleshooting Form

HEATING CYCLE ANALYSIS -

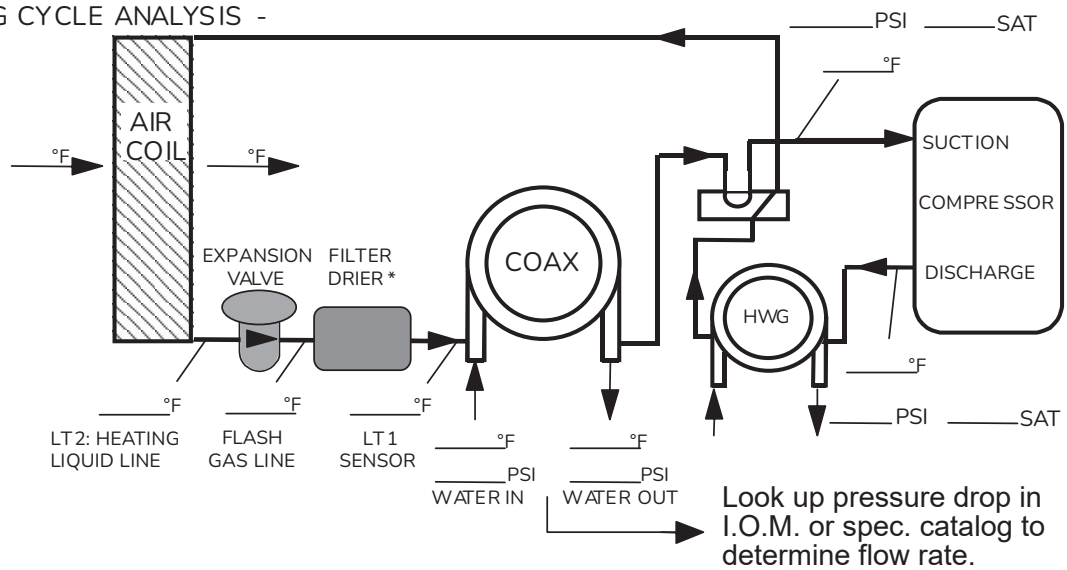

COOLING CYCLE ANALYSIS -

Refrigerant Type:

R-454B

Voltage: _____

Comp Amps: _____

Total Amps: _____

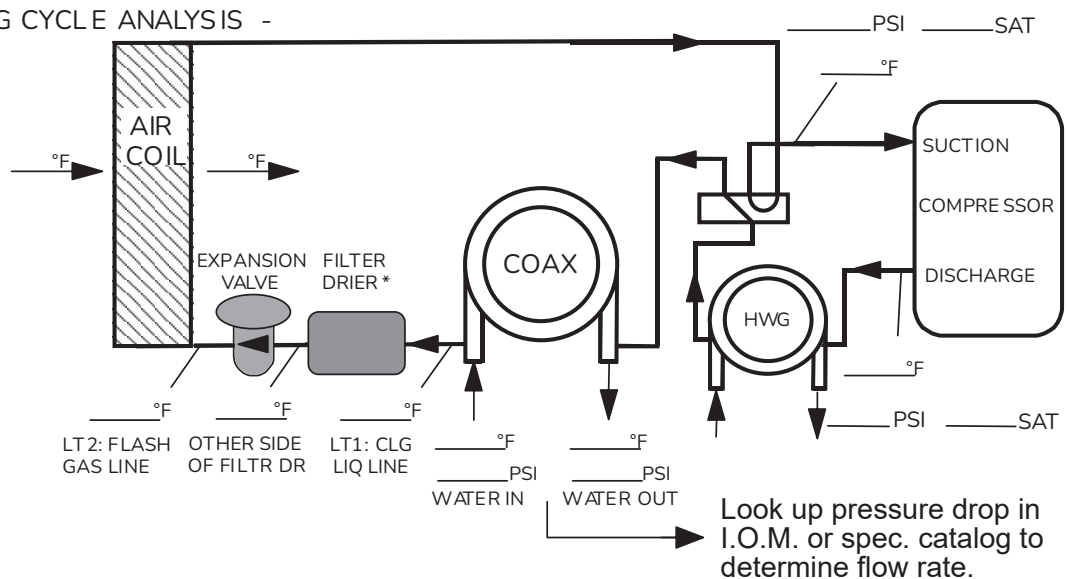

Heat of Extraction (Absorption) or Heat of Rejection =

$$\text{_____ flow rate (gpm) } \times \text{ _____ t emp.diff. (deg. F) } \times \text{ _____ fluid factor}^\dagger = \text{_____ (Btu/hr)}$$

Superheat = Suction temperature - suction saturation temp. = _____ (deg F)

Subcooling = Discharge saturation temp. - liquid line temp. = _____ (deg F)

† Use 500 for water, 485 for antifreeze.

Models:
SZ
024-060

Warranty (U.S. and Canada)

CLIMATE MASTER, INC. LIMITED EXPRESS WARRANTY/ LIMITATION OF REMEDIES AND LIABILITY



It is expressly understood that unless a statement is specifically identified as a warranty, statements made by Climate Master, Inc., a Delaware corporation, ("CM") or its representatives, relating to CM's products, whether oral, written or contained in any sales literature, catalog or any other agreement, are not express warranties and do not form a part of the basis of the bargain, but are merely CM's opinion or commendation of CM's products.

EXCEPT AS SPECIFICALLY SET FORTH HEREIN, THERE IS NO EXPRESS WARRANTY AS TO ANY OF CM'S PRODUCTS. CM MAKES NO WARRANTY AGAINST LATENT DEFECTS. CM MAKES NO WARRANTY OF MERCHANTABILITY OF THE GOODS OR OF THE FITNESS OF THE GOODS FOR ANY PARTICULAR PURPOSE.

GRANT OF LIMITED EXPRESS WARRANTY
CM warrants CM products purchased and retained in the United States of America and Canada to be free from defects in material and workmanship under normal use and maintenance as follows: (1) All complete air conditioning, heating and/or heat pump units built or sold by CM for twelve (12) months from date of unit start up or eighteen (18) months from date of shipment (from factory), whichever comes first; (2) Repair and replacement parts, which are not supplied under warranty, for ninety (90) days from date of shipment (from factory). All parts must be returned to CM's factory in Oklahoma City, Oklahoma, freight prepaid, no later than sixty (60) days after the date of the failure of the part; if CM determines the part to be defective and within CM's Limited Express Warranty, CM shall, when such part has been either replaced or repaired, return such a to a factory recognized dealer, contractor or service organization, F.O.B. CM's factory, Oklahoma City, Oklahoma, freight prepaid. The warranty on any parts repaired or replaced under warranty expires at the end of the original warranty period.

This warranty does not cover or apply to: (1) Air filters, fuses, refrigerant, fluids, oil; (2) Products relocated after initial installation; (3) Any portion or component of any system that is not supplied by CM, regardless of the cause of the failure of such portion or component; (4) Products on which the unit identification tags or labels have been removed or defaced; (5) Products on which payment to CM is or has been in default; (6) Products which have defects or damage which result from improper installation, wiring, electrical imbalance characteristics or maintenance; or are caused by accident, misuse or abuse, fire, flood, alteration or misapplication of the product; (7) Products which have defects or damage which result from a contaminated or corrosive air or liquid supply, operation at abnormal temperatures, or unauthorized opening of refrigerant circuit; (8) Mold, fungus or bacteria damages; (9) Products subjected to corrosion or abrasion; (10) Products manufactured or supplied by others; (11) Products which have been subjected to misuse, negligence or accidents; (12) Products which have been operated in a manner contrary to CM's printed instructions; or (13) Products which have defects, damage or insufficient performance as a result of insufficient or incorrect system design or the improper application of CM's products.

CM is not responsible for: (1) The costs of any fluids, refrigerant or other system components, or associated labor to repair or replace the same, which is incurred as a result of a defective part covered by CM's Limited Express Warranty; (2) The costs of labor, refrigerant, materials or service incurred in removal of the defective part, or in obtaining and replacing the new or repaired part; or, (3) Transportation costs of the defective part from the installation site to CM or of the return of any part not covered by CM's Limited Express Warranty.

Limitation: This Limited Express Warranty is given in lieu of all other warranties. If, notwithstanding the disclaimers contained herein, it is determined that other warranties exist, any such warranties, including without limitation any express warranties or any implied warranties of fitness for particular purpose and merchantability, shall be limited to the duration of the Limited Express Warranty.

LIMITATION OF REMEDIES
In the event of a breach of the Limited Express Warranty, CM will only be obligated at CM's option to repair the failed part or unit or to furnish a new or rebuilt part or unit in exchange for the part or unit which has failed. If after written notice to CM's factory in Oklahoma City, Oklahoma of each defect, malfunction or other failure and a reasonable number of attempts by CM to correct the defect, malfunction or other failure and the remedy fails of its essential purpose, CM shall refund the purchase price paid to CM in exchange for the return of the sold goods(s). Said refund shall be the maximum liability of CM. **THIS REMEDY IS THE SOLE AND EXCLUSIVE REMEDY OF THE BUYER OR THEIR PURCHASER AGAINST CM FOR BREACH OF CONTRACT, FOR THE BREACH OF ANY WARRANTY OR FOR CM'S NEGLIGENCE OR IN STRICT LIABILITY.**

LIMITATION OF LIABILITY
CM shall have no liability for any damages if CM's performance is delayed for any reason or is prevented to any extent by any event such as, but not limited to: any war, civil unrest, government restrictions or restraints, strikes or work stoppages, fire, flood, accident, shortages of transportation, fuel, material, or labor, acts of God or any other reason beyond the sole control of CM. **CM EXPRESSLY DISCLAIMS AND EXCLUDES ANY LIABILITY FOR CONSEQUENTIAL OR INCIDENTAL DAMAGE IN CONTRACT, FOR BREACH OF ANY EXPRESS OR IMPLIED WARRANTY, OR IN TORT, WHETHER FOR CM'S NEGLIGENCE OR AS STRICT LIABILITY.**

OBTAINING WARRANTY PERFORMANCE
Normally, the contractor or service organization who installed the products will provide warranty performance for the owner. Should the installer be unavailable, contact any CM recognized dealer, contractor or service organization. If assistance is required in obtaining warranty performance, write or call:

Climate Master, Inc. • Customer Service • 7300 S.W. 44th Street • Oklahoma City, Oklahoma 73179 (405) 745-6000

NOTE: Some states or Canadian provinces do not allow limitations on how long an implied warranty lasts, or the limitation or exclusions of consequential or incidental damages, so the foregoing exclusions and limitations may not apply to you. This warranty gives you specific legal rights, and you may also have other rights which vary from state to state and from Canadian province to Canadian province.

Please refer to the CM Installation, Operation and Maintenance Manual for operating and maintenance instructions.



Rev.: 11/09

Warranty (International)

CLIMATE MASTER, INC. LIMITED EXPRESS WARRANTY /LIMITATION OF REMEDIES AND LIABILITY (FOR INTERNATIONAL CLASS PRODUCTS)



This warranty does not cover and does not apply to: (1) Air filters, fuses, refrigerant, fluids, oil; (2) Products released after initial installation; (3) Any portion or component of any system that is not supplied by CM, regardless of the cause of the failure of such portion or component; (4) Products on which the unit identification tags or labels have been removed or defaced; (5) Products on which payment by Customer to CM or its distributors or Representatives, or the Customer's seller is in default; (6) Products which have defects or damage which result from improper installation, wiring, electrical imbalance characteristics or maintenance; or from parts or components manufactured by others; or are caused by accident, misuse, negligence, abuse, fire, flood, lightning, alteration or misapplication of the product; (7) Products which have defects or damage which result from a contaminated or corrosive air or liquid supply, operation at abnormal temperatures or flow rates, or unauthorized opening of the refrigerant circuit; (8) Mold, fungus or bacteria damages; (9) Products subjected to corrosion or abrasion; (10) Products, parts or components manufactured or supplied by others; (11) Products which have been subjected to misuse, negligence or accidents; (12) Products which have been operated in a manner contrary to CM's printed instructions; (13) Products which have defects, damage or insufficient performance as a result of insufficient or incorrect system design or the improper application, installation, or use of CM's products; or (14) Electricity or fuel costs, or any increases or unrealized savings in same, for any reason.

CM is not responsible for: (1) The cost of any fluids, refrigerant or other system components, or the associated labor to repair or replace the same, which is incurred as a result of a defective part covered by CM's Limited Express Warranty; (2) The cost of labor, refrigerant, materials or service incurred in diagnosis and removal of the defective part, or in obtaining and replacing the new or repaired part; (3) Transportation costs of the defective part from the installation site to CM or of the return of any part not covered by CM's Limited Express Warranty; or (4) The costs of normal maintenance.

Limitation: This Limited Express Warranty is given in lieu of all other warranties. If, notwithstanding the disclaimers contained herein, it is determined by a court or other qualified judicial body that other warranties exist, any such warranty, including without limitation any express warranty or any implied warranty of fitness for particular purpose and merchantability, shall be limited to the duration of the Limited Express Warranty. This Limited Express Warranty does not exclude any warranty that is mandatory and that may not be excluded under applicable imperative law.

LIMITATION OF REMEDIES
In the event of a breach of this Limited Express Warranty or any warranty that is mandatory under applicable imperative law, CM will only be obligated at CM's option to either repair the failed part or unit or to furnish a new or rebuilt part or unit in exchange for the part or unit which has failed. If after written notice to CM's factory in Oklahoma City, Oklahoma, U.S.A. of each defect, malfunction or other failure and a reasonable number of attempts by CM to correct the defect, malfunction or other failure and the remedy fails of its essential purpose, CM shall refund the purchase price paid to CM in exchange for the return of the sold good(s). Said refund shall be the maximum liability of CM. **TO THE FULLEST EXTENT PERMITTED BY APPLICABLE LAW, THIS REMEDY IS THE SOLE AND EXCLUSIVE REMEDY OF THE CUSTOMER AGAINST CM FOR BREACH OF CONTRACT, FOR THE BREACH OF ANY WARRANTY OR FOR CM'S NEGLIGENCE OR IN STRICT LIABILITY.**

LIMITATION OF LIABILITY
CM shall have no liability for any damages if CM's performance is delayed for any reason or is prevented to any extent by any event such as, but not limited to: any war, civil unrest, government restrictions or restraints, strikes, or work stoppages, fire, flood, accident, allocation, shortages of transportation, fuel, materials, or labor, or any other reason beyond the sole control of CM. **TO THE FULLEST EXTENT PERMITTED BY APPLICABLE LAW AND SUBJECT TO THE NEXT SENTENCE, CM EXPRESSLY DISCLAIMS AND EXCLUDES ANY LIABILITY FOR LOSS OF PROFITS, LOSS OF BUSINESS OR GOODWILL, CONSEQUENTIAL, INCIDENTAL, SPECIAL, LIQUIDATED, OR PUNITIVE DAMAGE IN CONTRACT, FOR BREACH OF ANY EXPRESS OR IMPLIED WARRANTY, OR IN TORT, WHETHER FOR CM'S NEGLIGENCE OR AS STRICT LIABILITY.** Nothing in this Agreement is intended to exclude CM's liability for death, personal injury or fraud.

OBTAINING WARRANTY PERFORMANCE
Normally, the contractor or service organization who installed the products will provide warranty performance for the owner. Should the installer be unavailable, contact any CM recognized Representative. If assistance is required in obtaining warranty performance, write or call:

Climate Master, Inc. • Customer Service • 7300 S.W. 44th Street • Oklahoma City, Oklahoma, U.S.A. 73179 • (405) 745-6000 • FAX (405) 745-6068

NOTE: Some countries do not allow limitations on how long an implied warranty lasts, or the limitation or exclusions of consequential or incidental damages, so the foregoing exclusions and limitations may not apply to you. This warranty gives you specific legal rights, and you may also have other rights which vary from state to state and country to country.

Please refer to the CM Installation, Operation and Maintenance Manual for operating and maintenance instructions.

Created: 10/09

CLIMATE MASTER, INC.
LIMITED EXPRESS WARRANTY /LIMITATION OF REMEDIES AND LIABILITY
(FOR INTERNATIONAL CLASS PRODUCTS)

CLIMATE MASTER, INC.
LIMITED EXPRESS WARRANTY /LIMITATION OF REMEDIES AND LIABILITY
(FOR INTERNATIONAL CLASS PRODUCTS)

CLIMATE MASTER, INC.
LIMITED EXPRESS WARRANTY /LIMITATION OF REMEDIES AND LIABILITY
(FOR INTERNATIONAL CLASS PRODUCTS)

CLIMATE MASTER, INC.
LIMITED EXPRESS WARRANTY /LIMITATION OF REMEDIES AND LIABILITY
(FOR INTERNATIONAL CLASS PRODUCTS)

CLIMATE MASTER, INC.
LIMITED EXPRESS WARRANTY /LIMITATION OF REMEDIES AND LIABILITY
(FOR INTERNATIONAL CLASS PRODUCTS)

CLIMATE MASTER, INC.
LIMITED EXPRESS WARRANTY /LIMITATION OF REMEDIES AND LIABILITY
(FOR INTERNATIONAL CLASS PRODUCTS)

CLIMATE MASTER, INC.
LIMITED EXPRESS WARRANTY /LIMITATION OF REMEDIES AND LIABILITY
(FOR INTERNATIONAL CLASS PRODUCTS)

CLIMATE MASTER, INC.
LIMITED EXPRESS WARRANTY /LIMITATION OF REMEDIES AND LIABILITY
(FOR INTERNATIONAL CLASS PRODUCTS)



Models:
SZ
024-060

Notes

Notes

Models:
SZ
024-060

Models:
SZ
024-060

Revision History

Date	Section	Description
04/08/24	Model Nomenclature	Updated Model Nomenclature
01/18/24	All	Created



A NIBE GROUP MEMBER

7300 SW 44th St. | Oklahoma City, OK 73179
 Phone: 1-800-299-9747
www.climatemaster.com



ClimateMaster works continually to improve its products. As a result, the design and specifications of each product at the time of order may be changed without notice and may not be as described herein. Please contact ClimateMaster's Customer Service Department at (405) 745-6000 for specific information on the current design and specifications. Statements and other information contained herein are not express warranties and do not form the basis of any bargain between the parties, but are merely ClimateMaster's opinion or commendation of its products. The latest version of this document is available at www.climatemaster.com.

Engineered and assembled in the USA.

© ClimateMaster, Inc. All Rights Reserved 2024