



HS/HL/HP and VS/VL/VP Series

Horizontal & Vertical Series Water Source Heat Pumps

Installation, Operation, & Maintenance Instructions



TABLE OF CONTENTS

	Page
General Information	3
Inspection	3
Introduction	3
Storage	3
Unit Protection	3
Pre-Installation	3
Location and Access-Horizontal Units	4
Location and Access-Vertical Units	5
Installation	6
Installation of Supply and Return Piping	6
Condensate Piping	6
Hanging and Mounting a Horizontal Unit	7
Sound Attenuation for Horizontal Units	8
Installing a Vertical Unit	8
Sound Attenuation for Vertical Units	8
Electrical Wiring	8
Operating Limits	9
Starting Conditions	9
Start-Up Preparation	9
System Checkout	10
Unit Start-Up	11
Warranty	13
Maintenance	BC
Maintenance Procedures	BC
Safety Control Reset	BC

GENERAL INFORMATION

Inspection

Upon receipt of shipment at the job site, carefully check the shipment against the bill of lading. Make sure all units have been received. Verify Hanger Brackets are located inside the fan compartment of Horizontal Units. Inspect the carton or crating of each unit, and inspect each unit for damage. Assure that the carrier makes proper notation of any shortages or damage on all copies of the freight bill and he/she completes a Carrier Inspection Report. Concealed damage not discovered during unloading must be reported to the carrier within 15 days of receipt of shipment. **Note: It is the responsibility of the purchaser to file all necessary claims with the carrier. Notify the ClimateMaster Traffic Department of all damage within fifteen (15) days of shipment.**

Introduction

This Installation, Operation and Maintenance Manual is for ClimateMaster Horizontal and Vertical Water Source Heat Pump systems (HS/HL/HP & VS/VL/VP).

ClimateMaster Horizontal Water Source Heat Pump (HS/HL/HP) units are designed for installation above a false ceiling or in a ceiling plenum. Vertical (VS/VL/VP) units are typically installed in a floor level closet or in a small mechanical room. The installation site chosen for these units must allow adequate clearance for maintenance and servicing of the unit without its removal from the installation location.

Refer to project submittal drawings for specific unit technical data and wiring diagrams.

Storage

▲ CAUTION

DO NOT store or install Horizontal and Vertical units in corrosive environments or in locations subject to temperature or humidity extremes (e.g., attics, garages, rooftops, etc.). Corrosive conditions and high temperature or humidity can significantly reduce performance, reliability, and service life. Always move units in an upright position. Tilting units on their sides may cause equipment damage.

Upon the arrival of equipment at the job site, immediately store units in their shipping cartons in a clean, dry area. **Store units in an upright position at all times.** Stack Horizontal units a maximum of 4 units high. Stack vertical units a maximum of 3 units high. **DO NOT remove equipment from shipping cartons until equipment is required for installation.**

Unit Protection

Cover Horizontal and Vertical units on the job site with either shipping cartons, vinyl film, or an equivalent protective covering. Cap the open ends of pipes stored on the job site. In areas where painting, plastering, or the spraying of fireproof material has not been completed, all due precautions must be taken to avoid physical damage to the units and contamination by foreign material. Physical damage and contamination may prevent proper start-up and may result in costly equipment clean-up.

Examine all pipes, fittings, and valves before installing any of the system components. Remove any dirt found on these components.

Pre-Installation

Installation, Operation and Maintenance (IOM) instructions are provided with each unit. Before unit start-up, read all manuals and become familiar with the unit and its operation. Thoroughly check the system before operation.

Prepare Horizontal and Vertical units for installation as follows:

1. Compare the electrical data on the unit nameplate with ordering and shipping information to verify the correct unit has been shipped.
2. Keep both the chassis and the cabinet covered with the shipping carton until installation is complete and all plastering, painting, etc., is finished.
3. Verify refrigerant tubing is free of kinks or dents and it does not touch other unit components.
4. Inspect all electrical connections. Connections must be clean and tight at the terminals.
5. Loosen compressor bolts on units equipped with compressor spring vibration isolation until the compressor rides freely on the springs. Remove shipping restraints. **Note: HP/VP units are not spring mounted, no further action is required.**
6. Some airflow patterns are field convertible. Contact your local sales representative for specific instructions.

▲ WARNING

To avoid equipment damage, DO NOT use these units as a source of heating or cooling during the construction process. The mechanical components and filters used in these units will quickly become clogged with construction dirt and debris which may cause system damage.

▲ WARNING

To avoid the release of refrigerant into the atmosphere, the refrigerant circuit of this unit **MUST** only be serviced by technicians who meet local, state and federal proficiency requirements.

All refrigerant discharged from this unit must be recovered without exception. Technicians **MUST** follow industry accepted guidelines and all local, state and federal statutes for the recovery and disposal of refrigerants.

When a compressor is removed from this unit, system refrigerant circuit oil will remain in the compressor. To avoid leakage of compressor oil, the refrigerant lines of the compressor **MUST** be sealed after it is removed.

Horizontal Units Location and Access

Horizontal Units are typically installed above a false ceiling or in a ceiling plenum. Refer to Figure 1 for an illustration of a typical installation. Install units with adequate clearance to allow maintenance and servicing without removal of the unit from the ceiling. Conform to the following guidelines when selecting unit location:

1. Provide a hinged access door in concealed-spline or plaster ceilings. Provide removable ceiling tiles in T-bar or lay-in ceilings. Refer to submittal drawing for Horizontal Unit Dimensions. Size the access opening to accommodate the service technician during the removal and replacement of the compressor and the removal and installation of the unit.
2. Provide access to hanger brackets, water valves and fittings. Provide screwdriver clearance to access

Figure 1. Typical Horizontal Installation

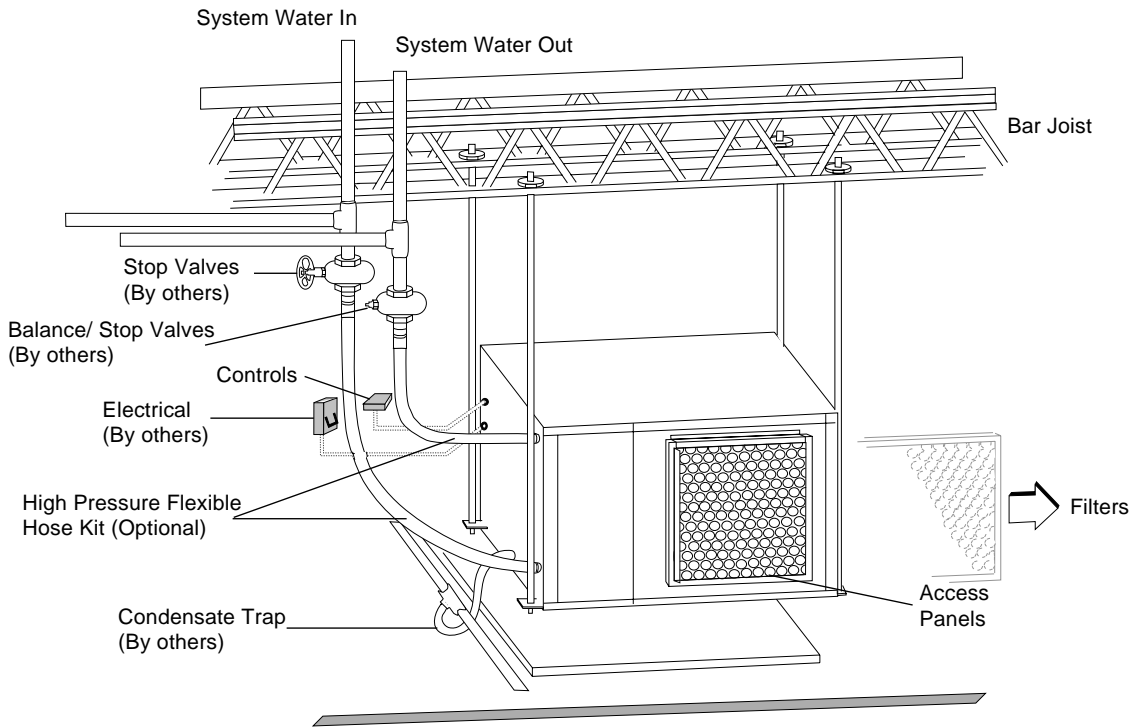
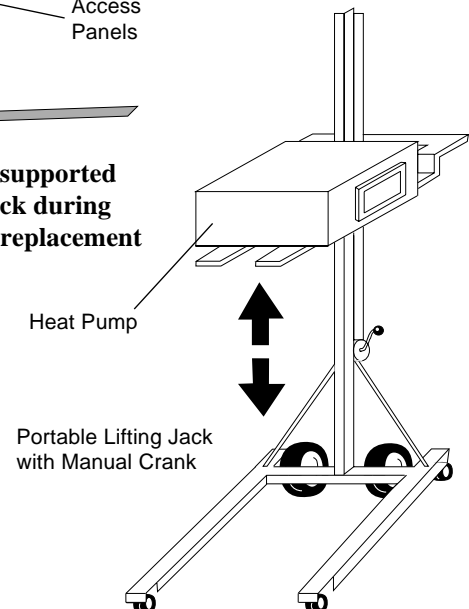

Figure 2. Unit supported by Portable Jack during installation or replacement



panels, discharge collars and all electrical connections.

3. Provide a duct slot for filter replacement, if a return duct is used.
4. DO NOT obstruct the space beneath the unit with piping, electrical cables and other items.
5. Refer to Figure 2. Use a manual portable jack to lift the unit and to support the weight of the unit during installation and servicing.

Vertical Units Location and Access

Vertical Units are typically installed in a floor level closet or in a small mechanical room. Refer to Figure 3 for an illustration of a typical installation. Install units

Figure 3. Vertical Installation

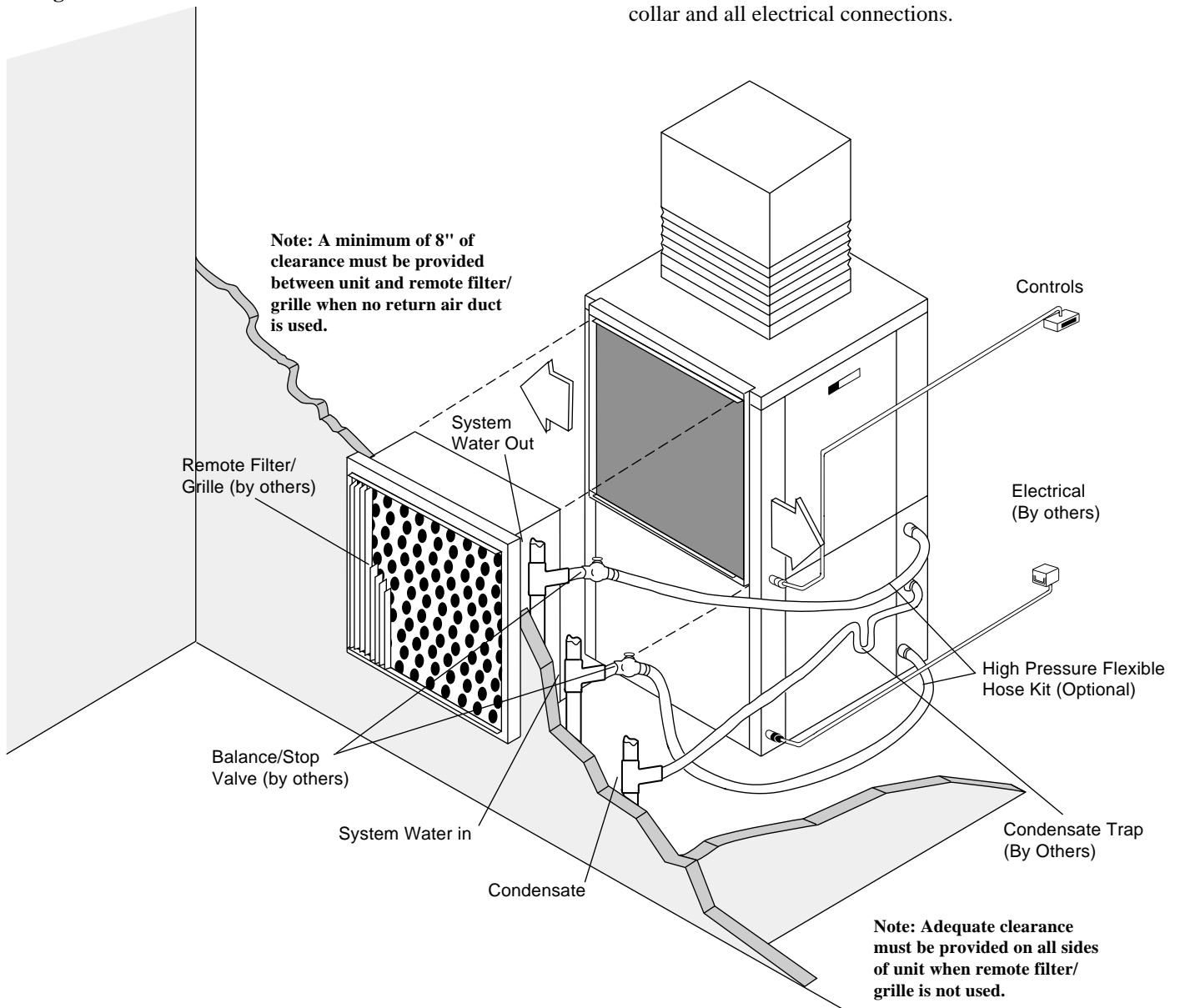

with adequate clearance to allow maintenance and servicing. Conform to the following guidelines when selecting unit location:

1. Provide adequate clearance for filter replacement and drain pan cleaning. DO NOT block filter access with piping, conduit or other materials. Refer to submittal drawing for Vertical Unit Dimensions.
2. Provide access for fan and fan motor maintenance and for servicing the compressor and coils without removal of the unit.
3. Provide an unobstructed path to the unit within the closet or mechanical room to enable removal of the unit, if necessary.
4. Provide access to water valves and fittings and screwdriver access to the unit side panels, discharge collar and all electrical connections.

INSTALLATION

The installation of Horizontal and Vertical Water Source Heat Pump units and all associated components, parts and accessories which make up the installation shall be in accordance with the regulations of ALL authorities having jurisdiction and MUST conform to all applicable Codes. It is the responsibility of the Installing Contractor to determine and comply with ALL applicable Codes and Regulations.

Installation of Supply and Return Piping

⚠ CAUTION

Piping must comply with all applicable codes.

Follow these piping guidelines.

1. Install a drain valve at the base of each supply and return riser to facilitate system flushing.
2. Install shut-off/balancing valves and unions at each unit to permit unit removal for servicing.
3. Place strainers at the inlet of each system circulating pump.
4. Select the proper hose length to allow slack between connection points. Hoses may vary in length by +2% to -4% under pressure.
5. Refer to Table 1. DO NOT exceed the minimum bend radius for the hose selected. Exceeding the minimum bend radius may cause the hose to collapse, which reduces water flow rate. Install an angle adapter to avoid sharp bends in the hose when the radius falls below the required minimum.

Table 1. Metal Hose Minimum Bend Radii

Hose in Inches	Minimum Bend Radius
1/2	2-1/2
3/4	4-1/2
1	5-1/2
1-1/4	6-3/4

Insulation is not required on loop water piping except where the piping runs through unheated areas or outside the building. Because loop temperature is normally between 60°F and 90°F, piping will not sweat nor suffer heat loss in normal ambient conditions. (HS/VS and HL,HP/VL,VP may require insulation if loopwater temperature drops below the dew point.)

Pipe joint compound is not necessary when Teflon threaded tape is pre-applied to hose assemblies or when flared-end connections are used. If pipe joint compound is preferred, use compound only in small amounts on the male pipe threads of the fitting adapters. Prevent sealant from reaching the flared surfaces of the joint. **Note: When anti-freeze is used in the loop, assure it is compatible with Teflon tape or the pipe joint compound used.**

Maximum allowable torque for brass fittings is 30 foot-pounds. If a torque wrench is not available, tighten finger-tight plus one quarter turn. Tighten steel fittings as necessary.

Ensure the trap is filled with water before operating the unit to avoid condensate pan overflow at initial start-up.

⚠ WARNING

DO NOT bend or kink supply lines or hoses.

Optional pressure-rated hose assemblies designed specifically for use with ClimateMaster units are available. Similar hoses can be obtained from alternate suppliers. Supply and return hoses are fitted with swivel-joint fittings at one end to prevent kinking during installation.

Refer to Figure 4 for an illustration of a Supply/Return Hose Kit. Male adapters secure hose assemblies to the unit and risers. Install hose assemblies properly and check them regularly to avoid system failure, reduced service life and possible damage to surrounding furniture and carpets.

Figure 4. Supply/Return Hose Kit

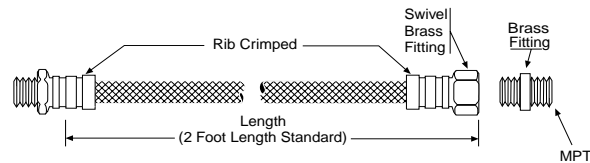

⚠ CAUTION

Corrosive system water requires corrosion-resistant fittings and hoses and may require water treatment.

Condensate Piping

Units are typically installed directly above each other on successive floors with condensate drains located near the units.

Connect the unit condensate drain connection to the building condensate drain with a flexible, non-pressure-rated 3/4 inch ID plastic hose. Ensure the hose is without kinks to maintain an unobstructed flow of condensate from the unit to the drain.

The horizontal run of a condensate hose is usually too short to cause drainage problems, however, the horizontal run of the condensate line should be pinched at least 1 inch for every 10 feet of run in the direction of flow. Avoid low points and unpitched piping since dirt collects in low or level areas and may cause stoppage and overflow.

Install a condensate trap at each unit with the top of the trap positioned below the unit condensate drain connection.

Figure 5 illustrates a typical trap and vent used with HS/HL/HP & VS/VL/VP Heat Pumps. Design the length of the trap (water-seal) based upon the amount of

Figure 5. Condensate Drain

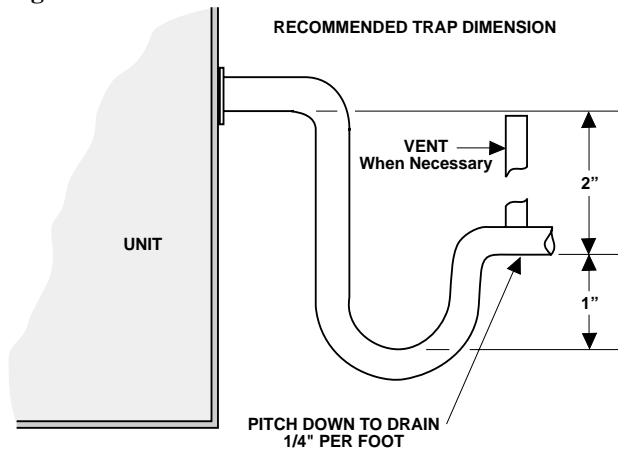

negative pressure on the drain pan. As a rule, 1" of trap is required for each inch of negative pressure on the unit.

Each unit must be installed with its own individual trap and connection to the condensate line (main) or riser. Provide a means to flush or blow-out the condensate drain line. **DO NOT** install units with a common trap and/or vent.

Install a vent in the condensate line of any application which may allow dirt or air to collect in the line. Always vent when the application requires a long, horizontal run, when some sagging in the condensate line may be anticipated (as in a long line of plastic pipe) or when "double trapping" may occur. Also vent when large units are working against higher external static pressure than other units connected to the same condensate main since this may cause poor drainage for all units on the line. When a vent is installed in the condensate line, it must be located after the trap in the direction of condensate flow.

Hanging or Mounting a Horizontal Unit

Horizontal heat pumps are typically suspended above a ceiling or within a soffit using field-supplied, threaded rods sized to support the weight of the unit.

A mounting kit including four (4) mounting brackets and four (4) vibration isolators is shipped inside the blower compartment of each unit.

Refer to Figure 6. Attach brackets and isolators to the bottom corners of the unit. Use four (4) field-supplied threaded rods to suspend the unit. Hang the unit clear of the floor slab above and support the unit by the mounting bracket assemblies only. **DO NOT attach the unit flush with the floor slab above.**

To avoid condensate overflow in Horizontal Units: Horizontal Units sizes 006-030 must be hung level to ensure proper condensate drainage. Horizontal Units sizes 036-120 must be hung pitched 1/4" to 1/2" toward the condensate drain connection to ensure proper drainage.

Follow clearance guidelines described in the *Location and Access* section of this manual. Provide adequate clearance within the plenum for filter removal. When the unit is installed with a return air plenum, provide a slot to remove the filter.

Figure 6. Hanger and Vibration Isolation Kit

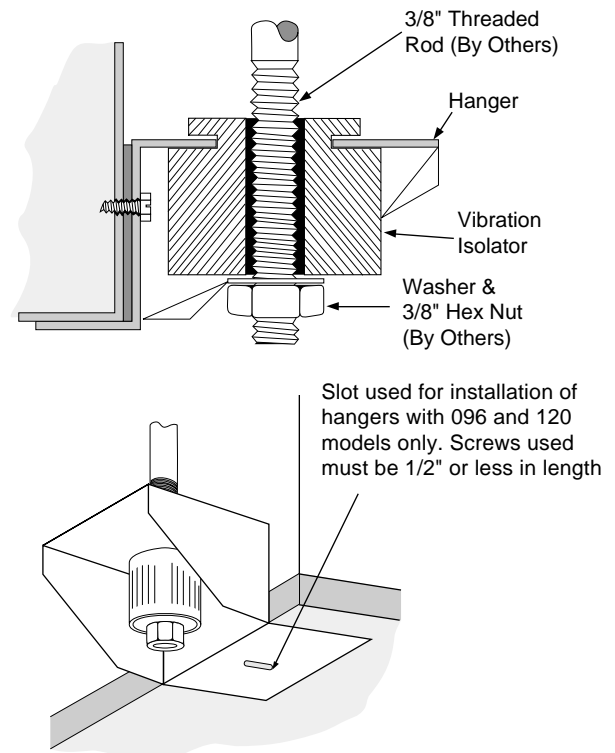

Notes: 1. Kits shipped unassembled and bulk-packed (4 hanger assemblies per unit) 2. Total head space required = unit height + 1/2 inch + condensate trapping. 3. See unit dimensional drawings for further information.

Sound Attenuation for Horizontal Units

Sound minimization is achieved by correct placement of the unit. Place the units so principal sound emission is outside the occupied, sound sensitive space.

Note: If a fire wall is penetrated, a fire damper may be required by local codes.

Lowest sound levels are obtained if the discharge duct has at least one 90° bend and the return is ducted. All ducts should be internally insulated

Installing a Vertical Unit

Vertical units are typically installed on the floor or on shelves designed to support the weight of the unit. Install the unit on a piece of rubber or neoprene for sound isolation. The pad should be 1/2" to 3/8" in thickness. Extend the pad beyond all four edges of unit.

Sound Attenuation for Vertical Units

Sound minimization is achieved by enclosing the unit within a small mechanical room or a closet. Additional measures for sound control include the following:

1. Mount the unit so the return air inlet is 90° to the return air grille. Refer to Figure 7. Install a sound baffle as illustrated to reduce line of sight sound transmitted through return air grilles.
2. Mount the unit on a rubber or neoprene isomode pad to minimize vibration transmission to the building structure. Extend the pad beyond all four edges of the unit.

Figure 7. Vertical Sound Attenuation

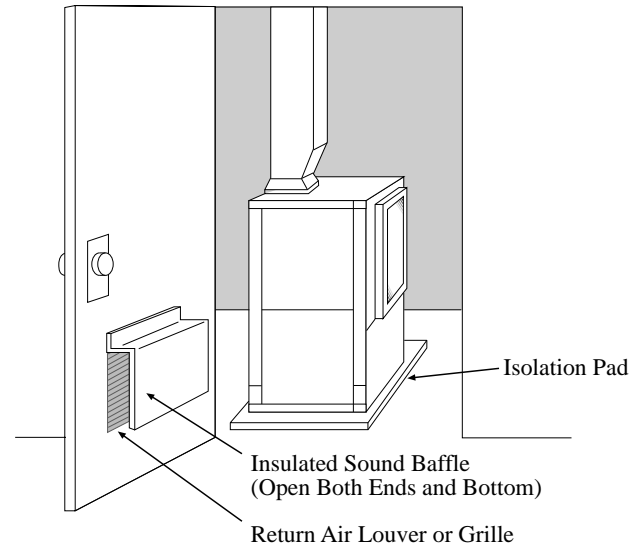

Refer to the unit wiring diagrams included with submittal drawings for fuse sizes and a schematic of the field connections which must be made by the installing (or electrical) contractor.

Consult the unit wiring diagram located on the inside of the compressor access panel to ensure proper electrical hookup.

Units rated 208-230 volts which have a 24 Volt transformer must have the transformer connection modified if the actual power supply is 230 volts. Refer to the unit wiring diagram for details of this procedure.

All final electrical connections must be made with a length of flexible conduit to minimize vibration and sound transmission to the building.

For additional wiring information pertinent to units supplied with a ClimateMaster CMC-2000 Series Control Board, refer to the CMC-2000 Series Installation, Operation Manual (p/n 69626515) supplied with this unit.

Electrical Wiring

⚠ WARNING ⚠

To avoid possible injury or death due to electrical shock, open the power supply disconnect switch and secure it in an open position during installation.

⚠ CAUTION

Use only copper conductors for field installed electrical wiring. Unit terminals are not designed to accept other types of conductors.

All field installed wiring, including electrical ground, must comply with the National Electrical Code (NEC) as well as all applicable local codes.

Typical Field Installed Wiring

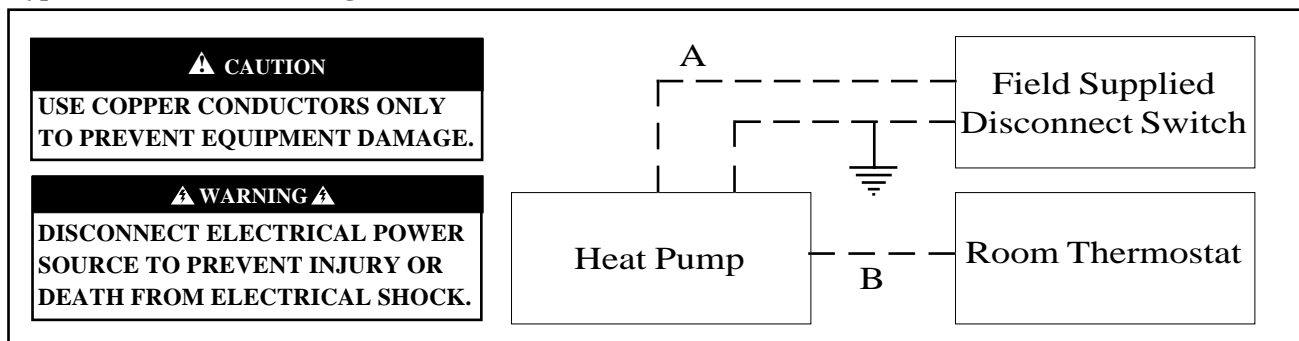

A= Two power wires on single-phase units; three power wires on three-phase units. B= 1 heat /1 cool /Manual or Auto Change-Over remote 24V thermostat. Note: All customer-supplied wiring to be copper only and must conform to NEC and local electrical codes. Wiring shown with dashed lines must be field-supplied and field-installed.

Operating Limits

Environment - This unit is designed for indoor installation ONLY.

Power Supply - A voltage variation of +/- 10% of nameplate utilization voltage is acceptable. Three-phase system imbalance shall not exceed 2%.

Starting Conditions

HS/HL/HP & VS/VL/VP Units - HS/HL/HP & VS/VL/VP Units start and operate in an ambient of 40°F with entering air at 40°F, entering water at 70°F and both air and water at the stated flow rates of ARI Standard 320-86 rating test for initial winter start-up.

HL/HP & VL/VP Units - HL/HP & VL/VP Units start and operate in an ambient of 40°F with entering air at 40°F, entering water at 40°F and both air and water at the stated flow rates of ARI Standard 320-86 rating test for initial winter start-up.

Notes

1. These are not normal or continuous operating conditions. It is assumed that winter start-up is to bring the building space up to occupancy temperatures.
2. Voltage utilization range complies with ARI Standard 110.
3. When using 100 percent outside air as a source of ventilation, a 40°F DB minimum (heating mode) and a 78°F WB maximum (cooling mode) are acceptable, but the cabinet may sweat during hot weather.

4. Determination of operating limits is dependent primarily upon three factors: 1) return air temperature, 2) water temperature and 3) ambient temperature. When any one of these factors is at minimum or maximum levels, the other two factors should be at normal levels to ensure proper unit operation (refer to Table 2).
5. Extreme variations in temperature and humidity and corrosive water or air will adversely affect unit performance, reliability and service life.

Table 2 Operating Limit

Air Limits	HS/VS		HL/HP & VL/VP	
	Cooling	Heating	Cooling	Heating
Min. Ambient Air	50°F	50°F	40°F	40°F
Rated Ambient Air	80°F	70°F	80°F	70°F
Max. Ambient Air	100°F	85°F	100°F	85°F
Min. Entering Air	50°F	50°F	50°F	40°F
Rated Entering Air db/wb	80/67°F	70°F	80/67°F	70°F
Max. Entering Air db/wb	110/83°F	80°F	110/83°F	80°F
Water Limits				
Min. Entering Water	55°F	55°F	40°F	40°F
Normal Entering Water	85°F	70°F	85°F	70°F
Max. Entering Water	110°F	90°F	110°F	90°F

START-UP PREPARATION

System Cleaning and Flushing

Cleaning and flushing the unit is the single most important step to ensure proper start-up and continued efficient operation of the system.

⚠ WARNING ⚠

To prevent injury or death due to electrical shock or contact with moving parts, open unit disconnect before servicing unit.

Follow the instructions below to properly clean and flush the system:

1. Verify electrical power to the unit is disconnected.
2. Install the system with the supply hose connected directly to the return riser valve. Use a single length of flexible hose.
3. Open all air vents. Fill the system with water. DO NOT allow system to overflow. Bleed all air from the system. Check the system for leaks and repair appropriately.
4. Verify all strainers are in place. Start the pumps, and systematically check each vent to ensure all air is bled from the system.
5. Verify make-up water is available. Adjust make-up water appropriately to replace the air which was bled from the system. Check and adjust the water/air level in the expansion tank.
6. Set the boiler to raise the loop temperature to approximately 85°F. Open a drain at the lowest point in the system. Adjust the make-up water replacement rate to equal the rate of bleed.

7. Refill the system and add trisodium phosphate in a proportion of approximately one pound per 150 gallons of water. Reset the boiler to raise the loop temperature to about 100°F.

▲ CAUTION

To avoid possible damage to piping systems constructed of plastic piping, DO NOT allow loop temperature to exceed 110°F.

Circulate the solution for a minimum of eight to 24 hours. At the end of this period, shut off the circulating pump and drain the solution. Repeat system cleaning, if desired.

8. When the cleaning process is complete, remove the short-circuited hoses. Re-connect the hoses to the proper supply, and return the connections to each of the

Horizontal and Vertical units. Refill the system and bleed off all air.

9. Test the system pH with litmus paper. The system water should be slightly alkaline (pH 7.5 to 8.5). Add chemicals, as appropriate, to maintain acidity levels.

▲ CAUTION

DO NOT use “Stop-Leak” or any similar chemical agent in this system. Addition of these chemicals to the loop water will foul the system and will inhibit unit operation.

10. When the system is successfully cleaned, flushed, refilled and bled, check the main system panels, safety cutouts and alarms. Set the controls to properly maintain loop temperatures.

SYSTEM CHECKOUT

When the installation is complete and the system is cleaned and flushed, follow the System Checkout procedure outlined below:

- 1. **Voltage:** Ensure voltage is within the utilization range specifications of the unit compressor and fan motor.
- 2. **System Water Temperature:** Ensure it is within an acceptable range to facilitate start-up. (When conducting this check, also verify proper heating and cooling set points.)
- 3. **System Water pH:** Verify system water acidity (pH = 7.5 or 8.5). Proper pH promotes the longevity of hoses and heat exchangers.
- 4. **System Flushing:** Properly clean and flush system periodically. Ensure all supply and return hoses are connected end-to-end to facilitate system flushing and prevent fouling of the heat exchanger by system water. Water used in the system must be of potable quality and clean of dirt, piping slag, and chemical cleaning agents.
- 5. **Closed-Type Cooling Tower** (Open Tower with Heat Exchanger): Check equipment for proper temperature set points and operation.
- 6. **Balanced Water Flow Rate to Heat Pump:** Verify the inlet and outlet water temperatures are recorded as each heat pump unit is started. This check will eliminate nuisance unit trip-outs resulting from water velocities which are either too low or too high; it can also prevent the occurrence of erosive water flow rates.
- 7. **Standby Pump:** Verify the standby pump is properly installed and in operating condition.

- 8. **System Controls:** To ensure no catastrophic system failures occur, verify system controls are functioning and the sequencing is correct.
- 9. **Freeze Protection for Water System:** Verify freeze protection is provided for the outdoor portion of the loop water system. Inadequate freeze protection can cause system operating problems.

▲ CAUTION

To avoid equipment damage, DO NOT leave system filled in a building without heat during the winter unless anti-freeze is added to system water. Condenser coils never fully drain by themselves and will freeze unless winterized with anti-freeze.

- 10. **System Water Loop:** Verify all air is bled from the system. Air in the system impedes unit operation and causes corrosion in the system piping.
- 11. **Unit Filters:** To avoid system damage, ensure the unit filter is clean.
- 12. **Unit Fans:** Manually rotate fans to assure free rotation. Ensure fans are properly secured to the fan shaft. DO NOT oil fan motors on start-up since they are lubricated at the factory.
- 13. **System Control Center:** To ensure control of the temperature set-points for operation of the system’s heat rejector and boiler, examine the system control and alarm panel for proper installation and operation.
- 14. **Miscellaneous:** Note any questionable aspects of the installation.

UNIT START-UP

Use the procedure below to initiate proper unit start-up:

WARNING

When the disconnect switch is closed, high voltage is present in some areas of the electrical panel. Exercise caution when working with energized equipment.

1. Adjust all valves to their full open position. Turn on the line power to all heat pump units.
2. Operate each unit in the cooling cycle. Room temperature should be approximately 70° to 75°F DB, and 61° to 65°F WB. Loop water temperature entering the heat pumps should be between 70°F and 110°F.

When the unit is operating in the cooling mode under ARI conditions, the leaving water temperature is approximately 10°F warmer than the entering water temperature at 3 GPM / ton.

Note: Three factors determine the operating limits of a Horizontal and Vertical unit: (1) return air temperature, (2) water temperature and (3) ambient temperature. When any one of these factors is at a minimum or maximum level, the other two factors must be at normal levels to ensure proper unit operation.

- a. Turn the unit thermostat to the coolest position. If the unit has an optional MCO thermostat, set the selector switch to COOL. Both the fan and compressor should run.
For heat pumps with an optional ACO thermostat, adjust the cooling set point to a temperature at least 3°F below room temperature.
- b. Check for cool air delivery at the unit grille within a few minutes after the unit has begun to operate. List the identification number of any machines which do not function.
- c. Check the elevation and cleanliness of the condensate lines. Dripping may be a sign of a blocked line.
3. Operate each heat pump in the heating cycle immediately after checking cooling cycle operation. A time delay will prevent the compressor from re-starting for approximately three minutes.

Note: Horizontal and Vertical heat pumps are designed to start heating at a minimum return air temperature of 50°F with normal water flow rate and ambient temperature.

- a. If the unit has an optional MCO thermostat, set the temperature indicator to the highest setting and set the selector switch to HEAT. The fan and the compressor should start.
If the unit has an optional ACO thermostat, set the temperature indicator to the far right setting, and set the selector switch to AUTO. The fan and the compressor should start.
- b. Once the unit has begun to run, check for warm air delivery at the unit grille. List the serial number of any machines which do not function.
4. Establish a permanent operating record by logging the unit operating conditions at initial start-up for each unit.
5. If a unit fails to operate, conduct the following checks:
 - a. Check the voltage and current. They should comply with the electrical specifications described on the unit nameplate.
 - b. Look for wiring errors. Check for loose terminal screws where wire connections have been made on both the line and low-voltage terminal boards.
 - c. Check for dirty filters. A clogged filter will cause safety cutouts to stop unit operation.
 - d. Check the supply and return piping. They must be properly connected to the inlet and outlet connections on the unit.
 - e. Check the fan. If the fan fails to operate, verify the fan wheel turns freely and is secured to the shaft. Also verify the fan operates in both heating and cooling modes.
 - f. If the checks described above fail to reveal the problem and the unit still will not operate, contact a trained service technician to ensure proper diagnosis and repair of the equipment.



CLIMATE MASTER®

CLIMATE MASTER, INC.

LIMITED EXPRESS WARRANTY/ LIMITATION OF REMEDIES AND LIABILITY

It is expressly understood that unless a statement is specifically identified as a warranty, statements made by Climate Master, Inc., a Delaware corporation, ("CM") or its representatives, relating to CM's products, whether oral, written or contained in any sales literature, catalog or agreement, are not express warranties and do not form a part of the basis of the bargain, but are merely CM's opinion or commendation of CM's products. **EXCEPT AS SPECIFICALLY SET FORTH HEREIN, THERE IS NO EXPRESS WARRANTY AS TO ANY OF CM'S PRODUCTS. CM MAKES NO WARRANTY AGAINST LATENT DEFECTS. CM MAKES NO WARRANTY OF MERCHANTABILITY OF THE GOODS OR OF THE FITNESS OF THE GOODS FOR ANY PARTICULAR PURPOSE.**

GRANT OF LIMITED EXPRESS WARRANTY

CM warrants CM products purchased and retained in the United States of America and Canada to be free from defects in material and workmanship under normal use and maintenance as follows: (1) All complete air conditioning, heating and/or heat pump units built or sold by CM for twelve (12) months from date of unit start-up or eighteen (18) months from date of shipment (from factory), whichever comes first; (2) Repair and replacement parts, which are not supplied under warranty, for ninety (90) days from date of shipment (from factory). All parts must be returned to CM's factory in Oklahoma City, Oklahoma, freight prepaid, no later than sixty (60) days after the date of the failure of the part; if CM determines the part to be defective and within CM's Limited Express Warranty, CM shall, when such part has been either replaced or repaired, return such to a factory recognized dealer, contractor or service organization, F.O.B. CM's factory, Oklahoma City, Oklahoma, freight prepaid. The warranty on any part repaired or replaced under warranty expires at the end of the original warranty period.

This warranty does not cover and does not apply to: (1) Air filters, fuses, refrigerant, fluids, oil; (2) Products relocated after initial installation; (3) Any portion or component of any system that is not supplied by CM, regardless of the cause of the failure of such portion or component; (4) Products on which the unit identification tags or labels have been removed or defaced; (5) Products on which payment to CM is or has been in default; (6) Products which have defects or damage which result from improper installation, wiring, electrical imbalance characteristics, or maintenance; or are caused by accident, misuse or abuse, fire, flood, alteration or mis-application of the product; (7) Products which have defects or damage which result from a contaminated or corrosive air or liquid supply, operation at abnormal temperatures, or unauthorized opening of refrigerant circuit; (8) Products subjected to corrosion or abrasion; (9) Products manufactured or supplied by others; (10) Products which have been subjected to misuse, negligence or accidents; (11) Products which have been operated in a manner contrary to CM's printed instructions; or (12) Products which have defects, damage or insufficient performance as a result of insufficient or incorrect system design or the improper application of CM's products.

CM is not responsible for: (1) The costs of any fluids, refrigerant or other system components, or associated labor to repair or replace the same, which is incurred as a result of a defective part covered by CM's Limited Express Warranty; (2) The costs of labor, refrigerant, materials or service incurred in removal of the defective part, or in obtaining and replacing the new or repaired part (except for the limited labor coverage set forth above); or (3) Transportation costs of the defective part from the installation site to ClimateMaster or of the return of any part not covered by CM's Limited Express Warranty.

Limitation: This Limited Express Warranty is given in lieu of all other warranties. If, notwithstanding the disclaimers contained herein, it is determined that other warranties exist, any such express warranty, including without limitation any express warranties or any implied warranties of fitness for particular purpose and merchantability shall be limited to the duration of the Limited Express Warranty.

LIMITATION OF REMEDIES

In the event of a breach of the Limited Express Warranty, CM will only be obligated at CM's option to repair the failed part or unit or to furnish a new or rebuilt part or unit in exchange for the part or unit which has failed. If, after written notice to CM's factory in Oklahoma City, Oklahoma of each defect, malfunction or other failure and a reasonable number of attempts by CM to correct the defect, malfunction or other failure and the remedy fails in its essential purpose, CM shall refund the purchase price paid to CM in exchange for the return of the sold goods. Said refund shall be the maximum liability of CM. **THIS REMEDY IS THE SOLE AND EXCLUSIVE REMEDY OF THE BUYER AGAINST CM FOR THE BREACH OF CONTRACT, FOR THE BREACH OF ANY WARRANTY OR FOR CM'S NEGLIGENCE OR IN STRICT LIABILITY.**

LIMITATION OF LIABILITY

CM shall have no liability for any damages if manufacture's performance is delayed for any reason or is prevented to any extent by any event such as, but not limited to any war, civil unrest, government restrictions or restraints, strikes or work stoppages, fire, flood, accident, shortage of transportation, fuel, material, or labor, acts of God or any other reason beyond the sole control of CM. **CM EXPRESSLY DISCLAIMS AND EXCLUDES ANY LIABILITY FOR CONSEQUENTIAL OR INCIDENTAL DAMAGE IN CONTRACT, FOR BREACH OF ANY EXPRESS OR IMPLIED WARRANTY, OR IN TORT, WHETHER FOR NEGLIGENCE OR AS STRICT LIABILITY.**

OBTAINING WARRANTY PERFORMANCE

Normally, the contractor or service organization who installed the products will provide warranty performance for the owner. Should the installer be unavailable, contact any CM recognized dealer, contractor or service organization. If assistance is required in obtaining warranty performance, write or call:

Climate Master, Inc. • Customer Service • 7300 S.W. 44th Street • Oklahoma City, Oklahoma 73179 (405) 745-6000

NOTE: Some states or Canadian provinces do not allow limitations on how long an implied warranty lasts, or the limitation or exclusions of consequential or incidental damages, so the foregoing exclusions and limitations may not apply to you. This warranty gives you specific legal rights, and you may also have other rights which vary from state to state and from Canadian province to Canadian province.

Please refer to the CM Installation, Operation and Maintenance Manual for operating and maintenance instructions.

Rev.: 10/00



LC083

MAINTENANCE

Maintenance Procedures

Perform the maintenance procedures outlined below periodically, as indicated.

⚠ WARNING ⚠

To prevent injury or death due to electrical shock or contact with moving parts, open unit disconnect switch before servicing unit.

Filters: Inspect filters. Establish a regular maintenance schedule. Clean filter, and maintenance frequently depending upon need.

To remove the filter from a Horizontal and Vertical unit, slide the filter out of its frame located in the return air opening at the bottom front of the unit. When re-installing the filter, use the slide-in rails of the filter frame to guide the filter into the proper position.

⚠ CAUTION

To avoid fouled machinery and extensive unit clean-up, DO NOT operate units without filters in place. DO NOT use equipment as a temporary heat source during construction.

Condensate Pans: Check condensate drain pans for algae growth every three months. If algae growth is apparent, consult a water treatment specialist for proper chemical treatment. The application of an algaecide every three months will typically eliminate algae problems in most locations.

Fan Motors: Lubricate fan motors annually. All ClimateMaster Horizontal and Vertical units are fully lubricated at the factory. **DO NOT** oil during installation. Conduct amperage checks annually. Amperage draw should not exceed normal full load or rated load amps by more than 10 percent of the values noted on the unit nameplate. Maintain a log of amperage values to detect deterioration prior to component failure.

Unit Inspection: Visually inspect the unit annually. Pay special attention to hose assemblies. Repair any leaks and replace deteriorated hoses immediately.

Compressor: Conduct an amperage check on the compressor annually. Amperage draw should not exceed normal full load or rated load amps by more than 10 percent of the values noted on the unit nameplate. Maintain a log of amperage values to detect deterioration prior to component failure.

⚠ WARNING

When replacing the compressor contactor or lockout relay in a unit with electromechanical controls, use only ClimateMaster replacement parts. Substitution of other components may result in an inoperative safety circuit and may cause a hazardous condition.

Heat Exchangers: Clean heat exchangers annually. Inspect heat exchangers regularly, and clean more frequently if the unit is located in a “dirty” environment.

Safety Control Reset

All ClimateMaster Horizontal and Vertical units are furnished with high and low pressure cutouts to prevent the machine from operating at abnormal or damaging temperature or water flow conditions.

The contacts of the high-pressure control used on Horizontal and Vertical units are designed to open at 380 psig and automatically close at 300 psig. The contacts of the low-pressure switch open at 10 psig and close at 32 psig. The contacts of the low-temperature switch open at 33.5°F and re-close at 45°F. A lockout relay, electrically linked with these cutouts, interrupts unit operation. The unit must be reset manually.

Note: If the unit must be reset more than twice, check the unit for a dirty filter, abnormal entering water temperature, inadequate or excessive water flow and internal malfunction. If the unit continues to cutout, contact a trained service technician.



Part #: 69197301



7300 S.W. 44th Street
Oklahoma City, OK 73179
Phone: 405-745-6000
Fax: 405-745-6058
www.climatemaster.com

ClimateMaster works continually to improve its products. As a result, the design and specifications of each product at the time of order may be changed without notice and may not be as described herein. Please contact ClimateMaster's Customer Service Department at 1-405-745-6000 for specific information on the current design and specifications. Statements and other information contained herein are not express warranties and do not form the basis of any bargain between the parties, but are merely ClimateMaster's opinion or commendation of its products.