



INSTALLATION INSTRUCTIONS

97B0042N04
REV.: December, 2020

ENERGY RECOVERY VENTILATOR

SERIES TB, TC, TD, TE, TF, & TG

Installation Instructions For Energy Recovery Ventilator (Fixed) For Stand Alone Side By Side Mechanical Room / Indoor Application



Energy recovery COMPONENT certified to the AHRI Air-to-Air Energy Recovery Ventilation Equipment Certification Program in accordance with AHRI Standard 1060-2000. Actual performance in packaged equipment may vary.



ETL Certified per UL 1995 and CSA 22.2

Inspection

Upon receipt of shipment at the job site, carefully check the shipment against the bill of lading. Make sure all units have been received. Inspect the carton or crating housing of each Rooftop Unit and inspect each unit for damage. Assure that the carrier makes proper notation of any shortages or damage on all copies of the freight bill and that he completes a Carrier Inspection Report. Concealed damage not discovered during unloading must be reported to the carrier within 15 days of receipt of shipment. **NOTE: It is the responsibility of the purchaser to file all necessary claims with the carrier.**

Storage

Upon the arrival of equipment at the job site, immediately store units in a clean, dry area. Do not stack units. **Do not remove equipment from pallets until equipment is required for installation.**

Unit Protection

Cover rooftop units on the job site. Cap the open ends of pipes. In areas where painting, plastering, roofing, or the spraying of fireproof material has not been completed, all due precautions must be taken to avoid physical damage to the units and contamination by foreign material. **Physical damage and contamination may prevent proper start-up and may result in costly equipment cleanup.**

Application

These **Energy Recovery Ventilators (ERV)** are designed to be primarily used in a horizontal discharge manner connected to ductwork in an side by side configuration and mounted inside* a building. They can be installed free standing on vibration isolators on the ground or hung from the structure in a manner that supports the 4 corners of the unit. These ventilators conserve energy by transferring humidity and heat energy across two opposing air streams using a rotary heat exchanger (the energy recovery wheel). This process works in the summer by rejecting heat energy from intake air and in the winter by conserving heat energy from the exhaust air, allowing outdoor ventilation rates to be increased by factors of three or more without additional energy penalty or increase in size of heating or air conditioning systems.

***These units are not approved for outdoor use.**

Rigging Unit For Lifting

1. Maximum weight 300-2200 lbs. See Physical Data Table.
2. Remove crating

3. All panels must be in place for lifting.
4. Remove box containing screws and accessories from the Controls section.
5. When hanging from the structure (usual installation) proper rigging should be used, Unistrut or angle iron is suitable along with (minimum) 3/8ths all-thread. Prepare rigging before lifting unit making sure that ERV will be supported at the 4 corners and that access panels will not be blocked.
6. Orientation of the unit is not important in so much as both blowers are sized equally and both air streams have filters before the energy recovery wheel, however caution should be taken that on units with low ambient frost control the blower with the low ambient kit is connected to the exhaust duct and that the unit is installed in a way that matches ductwork orientation for supply and exhaust air streams and provides clearance (30" minimum) to access unit for maintenance.
7. Lift unit into place.

⚠ CAUTION! ⚠

CAUTION! Danger of sharp metallic edges. Can cause injury. Take care when servicing unit to avoid accidental contact with sharp edges.

⚠ WARNING! ⚠

WARNING! Electric shock hazard. Can cause injury or death. Before attempting to perform any service or maintenance, turn the electrical power to unit OFF at disconnect switch(es). Unit may have multiple power supplies.

⚠ WARNING! ⚠

WARNING! To avoid equipment damage, do not use these units as a source of heat during the construction process. The mechanical components and filters used in these units will quickly become clogged with construction dirt and debris which may cause system damage.

⚠ WARNING! ⚠

WARNING! The installation of water-source heat pumps and all associated components, parts, and accessories which make up the installation shall be in accordance with the regulations of ALL authorities having jurisdiction and MUST conform to all applicable codes. It is the responsibility of the installing contractor to determine and comply with ALL applicable codes, regulations and ANSI/NFPA No. 70

T (ERV) Series

REV.: December, 2020

This Page Intentionally Left Blank

T Series Stand Alone ERV's for Side by Side Indoor Application

Features and Notes

1. Stand alone design allows higher levels of outdoor air to be introduced into the a/c space.
2. Static test ports provided to verify intake and exhaust CFM.
3. Balancing damper(s) is field provided when connected to ductwork. System will not operate properly without balancing damper.
4. See blower performance charts for airflow at various E.S.P..
5. Filter rack with 2" pleated filters included.

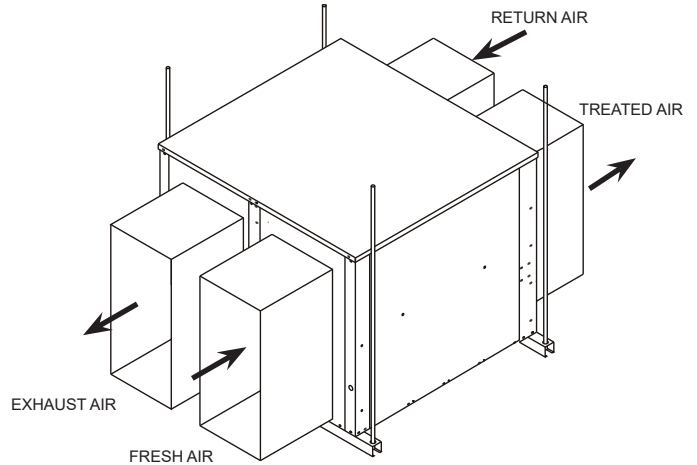

**ERV with Horizontal Ductwork
(balancing damper(s) field supplied)**

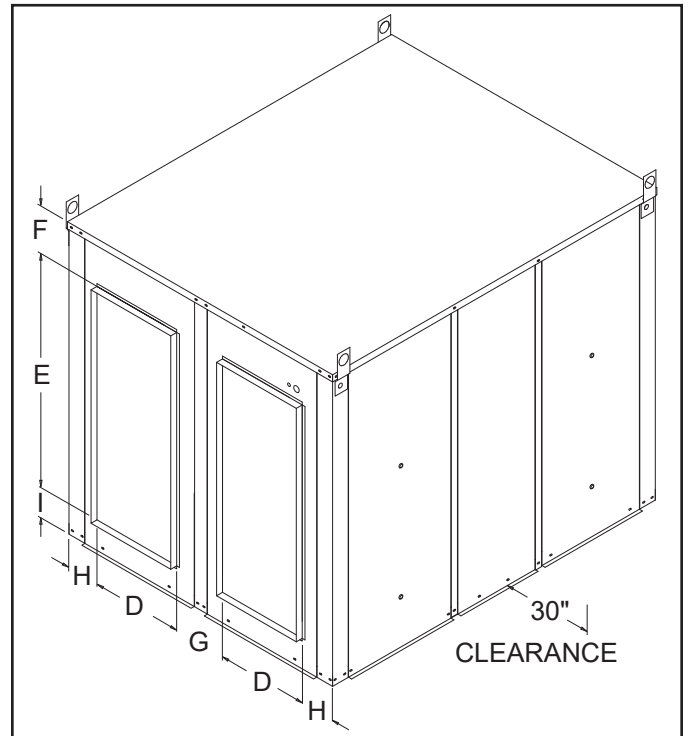
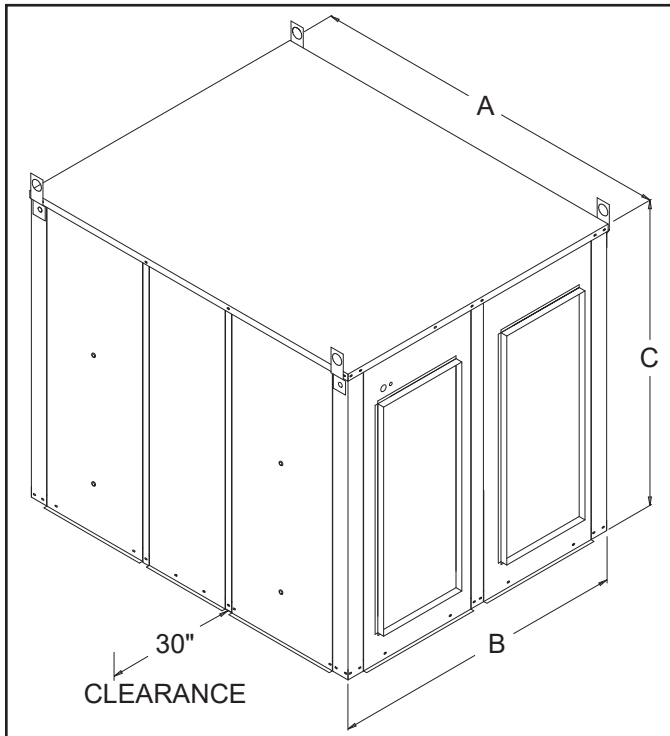

ERV Data		Dimensional Data								
ERV Series	CFM Range	A	B	C	D	E	F	G	H	I
TB	300-1100	44.75	32.13	33.50	11.00	27.00	4.00	4.25	2.88	2.50
TC	1200-2000	54.38	37.25	37.50	12.00	30.00	5.87	5.13	4.06	1.63
TD	1200-2800	52.25	42.63	43.56	14.00	32.00	8.69	5.25	4.25	2.88
TE	2000-3600	60.00	46.69	57.37	16.50	39.50	12.00	5.50	4.05	5.88
TF	3000-4600	60.00	52.69	57.37	16.50	39.50	12.00	8.69	5.50	5.88
TG	4600-6200	72.00	70.88	63.63	19.50	39.50	17.53	14.50	8.70	6.60

T (ERV) Series

REV. : December, 2020

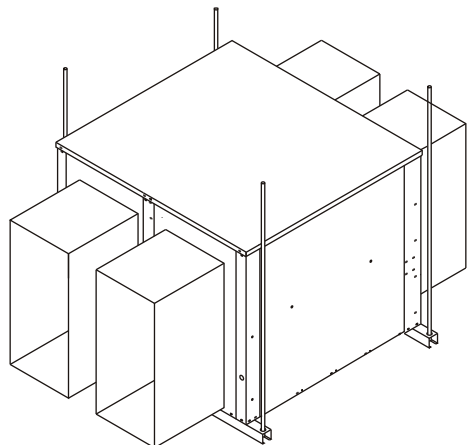
**Installation**

1. Attach ductwork to duct flanges on ERV, seal with foil tape or mastic.
2. Remove control access panel to connect field wiring.
3. Route Class II low voltage wire (3 conductor) from thermostat, relay, or Energy Management through small bushing provided on a panel near the controls section. Location varies by model.
4. Connect low voltage wires to terminals 1-3 on the control board according to the Mechanical Engineers chosen controls scheme. **See Stand Alone ERV Controls Schemes for options.**
5. On units with Variable Frequency Drives a separate terminal strip is provided to connect low voltage (0-10 VDC externally provided) controls for the Drives. **See Stand Alone ERV Controls Schemes / Optional Kits on Page 5.**

Due to size constraints factory installed dampers are not available, on applications where dampers are required, field installed dampers with 24v actuators are recommended and are available from manufacturer as an accessory kit.

6. Connect wires from dampers to the factory provided plugs (J160 and J161 on Wiring Diagram) making sure that the 24V+ and 24Vc are connected to the proper terminals. See installation instructions with damper kits for proper orientation and wiring.

High Voltage

7. All Electrical connections must conform to any local codes and current National Electric Codes (NEC) or Canadian Electric Codes (CEC). Refer closely to unit wiring diagram in the unit and/or in these instructions for proper wiring connections.
8. Refer to unit nameplate for minimum circuit ampacity (MCA) and maximum overcurrent protection size (fuse).
9. Electrical data is listed on unit rating plate as well as the motor name plates.
10. Connect line voltage power from field installed power disconnect to ERV fuse block in the control box of the unit. Use provided knockout on outside panel next to controls section. **See Wiring Diagrams on Pages 11-14.**
11. **Ground unit with suitable ground connection** either through unit supply wiring or to an earth ground.

12. Remove motor access panels, check that blowers have belts in place and that motors spin freely. Blower RPM can be adjusted to meet CFM and external static pressure requirements by adjusting the sheave on the blower motors and by replacing the pulley kits on units ordered without variable frequency drives. Multiple pulley arrangements are available from the manufacturer to meet the entire range of the units CFM options.

⚠CAUTION! ⚠

CAUTION! Blower speed must be adjusted for the given external static pressure and airflow (CFM) requirements. If blower speed is not adjusted for conditions, possible motor overloading can occur.

13. Start unit to test operation. Turn on power disconnect, turn on unit either from controls or by Jumping 24v+ from transformer (blue low voltage wire) to terminal #1. Check that motors are spinning the right direction (3 phase units only) that the enthalpy wheel is spinning and that motorized intake air and exhaust dampers are opening.

If unit is operating properly proceed to next step, if not operating properly **See Trouble shooting guide on Page 7.**

14. Clean up, caulk any open joints, holes or seams to make the unit air tight. Remove any jumpers, replace all access panels on the unit and secure.
15. Leave this instruction manual with the owner or in an envelope near the unit.

See System Check or Trouble shooting guide for further information on the proper operation of the ERV.

VIII - Stand Alone ERV Controls Schemes**Dependent options**

Thermostat: This is the standard way to wire an ERV, when the ductwork of the stand alone ERV is attached to the ductwork of a single AC system the controls of the ERV should be wired in parallel with the controls with "G" to 1, "C" to 2 and "W" to 3. The ERV will operate whenever the RTU's blower is operating.

Energy Management: Building Management Systems: The ERV needs a 24 Volt AC signal to operate, connect the 24V+ to 1 and the 24V C to 2, the unit can be operated off of a relay or BMS controller if necessary.

Dedicated Options

When using a control method that does not involve an outside 24V controls signal power can be borrowed from the unit's transformer for short thermostat wire runs. Any run over 150' however should be powered by a separate transformer.

Thermostat: When using an ERV to service a large area with multiple AC units or when not tying directly into the ductwork of a single AC system the ERV can be run off of its own Thermostat. Splice the 24V+ wire "R" onto the XFORMER + terminal of the ERV control board, then wire "G" and "C" onto terminals 1 and 2 respectively, program Thermostat to energize G when space is occupied.

CO₂ Sensor/ Transmitter: An ERV can be wired to a wall mounted CO₂ Sensor/ Transmitter with relay like Johnson Controls CD-WR0-00-0 (or CD-WRD-00-0) in order to operate the ERV when ventilation is required due to high CO₂ levels. This type of transmitter has an adjustable set point, and a relay that the 24V+ signal can be wired into and "G" wire can be wired

out of "G" should be wired to #1 terminal. The ERV will then turn on and provide fresh air to the space to lower CO₂ levels.

ON/OFF switch or Timer: Wire 24V+ from transformer onto the input of the switch and connect the output of the switch to terminal 1 on the control board. The ERV can be turned on manually or be set to turn on at a regular schedule when the building is occupied.

Quickstep: Units equipped with the quickstep controls option use an onboard microprocessor, factory installed CO₂ sensor, and Variable Frequency Drives to modulate airflow through the ERV to control for Carbon Dioxide. To operate the unit enter the Supply Air set point, Exhaust Air set point (they do not have to be the same value) into the units controls along with the maximum CO₂ set point. The unit will modulate the blowers to increase ventilation and decrease CO₂ when CO₂ levels are above the set point.

Input can be made by connecting the unit to a Bacnet compatible BMS or by using a JCI Metasys display screen or Bluetooth CVT to interface with the FEC controller. **See wiring diagram on Page 14.**

Operation

How It Works

The unit contains an energy recovery wheel (ERW) that is a revolutionary concept in rotary air-to-air heat exchangers. When slowly rotating through counter flowing exhaust and fresh air streams the ERW absorbs sensible heat and latent heat from the warmer air stream in the first half of its rotation and transfers this total energy to the cooler air stream during the second half of this rotating cycle. Rotating at 50-60 RPM, the ERW provides a constant flow of energy from the warmer to the cooler air stream. The large energy transfer surface and laminar flow through the ERW causes this constant flow of recovered energy to represent up to 85% of the difference in total energy contained within the two air streams.

Sensible and latent heat are the two components of total heat, sensible heat is energy contained in dry air and latent heat is the energy contained within the moisture of the air. The latent heat load from the outdoor fresh air on an air conditioning system can often be two to three times that of the sensible heat load and in the winter it is a significant part of a humidification heat load.

During both the summer and the winter, the ERW transfers moisture entirely in the vapor phase. This eliminates wet surfaces that retain dust and promote fungal growth as well as the need for a condensate pan and drain to carry water.

Because it is constantly rotating when in the air stream, the ERW is always being cleaned by air, first in one direction and then the other. Because it is always dry, dust or other particles impinging on the surface during one half of the cycle are readily removed during the next half of the cycle.

During the heating season, when outdoor air temperatures are below 15°F, it is recommended to use the (optional) low ambient kit.

Optional Kits

Motorized Intake Air Damper

This option is available as factory of field installed, mounted in the intake air opening of the ERV the Damper opens when the supply blower is energized and spring closes when de-energized. See section XV for field installation instructions

BACNET MAPPING LIST-QUICKSTEP	
Bacnet Mapping	Description (Control Points)
startUpInput	Parameter that is responsible for unit start up when it is controlled through a Bacnet network.
useCO2ControlMode	Parameter that sets the usage of CO2 Control Mode. Use this parameter to activate or deactivate the use of the CO ₂ Mode.
useLowAmbientMode	Parameter that sets the usage of the Low Ambient Mode. Use this parameter to activate or deactivate the use of the Low Ambient Mode.
laMinTemp	Parameter that sets the minimum temperature that the unit will use to engage the Low Ambient Mode.
saCFMSetPointInput	Parameter that sets the unit's supply air cfm set point. This input goes through validation sequence that sets the machine's set point to be within the CFM range.
eaCFMSetPointInput	Parameter that sets the machine's exhaust cfm set point. This input goes through validation sequence that sets the machine's set point to be within the CFM range.
co2SetPointInput	Parameter that sets the unit's CO ₂ set point. This input goes through validation that sets the unit's set point to be within the CO ₂ range.

Bacnet Mapping	Description (Monitoring Points)
Firmware_Ver	Firmware Version
startUp	Start Up Flag. This indicates if the unit is in operation.
occupied	Occupied Flag. This indicates if the unit received an occupied signal.
saCFMSetPoint	Supply CFM Validated Set Point.
saSetPointOutOfRange	Supply Air CFM Set Point Out Of Range Alarm
saCFMValue	Supply Air CFM Value.
eaCFMSetPoint	Exhaust Air CFM Validated Set Point.
eaSetPointOutOfRange	Exhaust Air CFM Set Point Out Of Range Alarm
eaCFMValue	Exhaust Air CFM Value.
co2SetPoint	CO ₂ Validated Set Point.
co2SetPointOutOfRange	CO ₂ Set Point Out Of Range Alarm
co2Value	CO ₂ Value.
oaTempValue	Outside Air Temperature Value.
eaTempValue	Exhaust Air Temperature Value.
eaDPValue	Differential Pressure value across the wheel in the exhaust air and return air quadrants.
saDPValue	Differential Pressure value across the wheel in the supply air and outside air quadrants.
smokeControlMode	Smoke Control Flag. This indicates if the unit is running in Smoke Control Mode.
laControlMode	Low Ambient Control Flag. This indicates if the unit is running in Low Ambient Control Mode.
co2ControlMode	CO ₂ Control Flag. This indicates if the unit is running in CO ₂ Control Mode.
wheelModulationMode	Wheel Modulation Mode Control Flag. This indicates that the unit is running in Wheel Modulation Mode Control. This mode is optional.
ssjControlMode	Start Stop Jog Control Flag. This indicates if the unit is running in Start Stop Jog Control Mode. This mode is optional.
wheelFailureAlarm	Wheel Failure Alarm. This indicates if the Wheel has failed.

T (ERV) Series

REV. : December, 2020

Motorized Exhaust Air Damper

All ERVs are prewired for power open/spring return motorized exhaust dampers. For best performance a damper assembly should be ordered to the same dimensions as the exhaust air ductwork chosen for the job with the linkage and actuator on the outside to maximize airflow. This can then be connected to the 3 pin jack (J161) with 24v & com available near the exhaust blower. Damper assemblies should be placed at least 36 inches away from the exhaust blower to prevent deadheading.

Pressure Sensors

Measurement devices (Magnahelics) on ERV that measure pressure across the energy recovery wheel.

Rotation Sensor

A magnetic sensor and logic board that measure pulses from a magnet on the spinning energy recovery wheel. A lack of measured pulses after initial start up results in an alarm. The alarm can be wired into building management hardware or to a thermostat with alarm switch terminals, it will warn that the wheel has stopped spinning, but does not otherwise effect operation.

Stop, Start, Jog [Climate Smart]

This option adds an Economizer or free cooling mode to the ERV. The wheel stops spinning to allow air to pass without energy transfer, starting and spinning intermittently in order to keep the wheel clean.

Low Ambient Kit

Prevents frost buildup on energy recovery wheel by terminating intake air when the discharge air temperature falls below a set level. Intake blower operation resumes after a 16°F rise above the field adjustable set point.

The frost threshold is the outdoor temperature at which frost will begin to form on the ERV wheel. For energy recovery ventilators, the frost is typically below 10°F. Frost threshold is dependent on indoor temperature and humidity. The table shows how the frost threshold temperatures vary depending on indoor conditions.

FROST THRESHOLD TEMPERATURE	
INDOOR RH AT 70°F	FROST THRESHOLD TEMPERATURE
20%	0°F
30%	5°F
40%	10°F

Because energy recovery ventilators have a low frost threshold, frost control options are not necessary in many climates. The Low Ambient Kit is available for units installed where outdoor temperatures may drop below the frost threshold during the ERV operational hours.

Filter Racks/ Filter Options

Indoor units come with intake air and exhaust air filter racks and filters standard, MERV 8, 11, or 13 filters can be ordered with the unit.

Dirty Filter Switches

Pressure differential switches that can be hooked up to an alarm to alert when pressure drops across a filter bank indicating dirty or clogged filter, they do not otherwise effect operation.

Wheel Type

While the standard energy recovery wheel absorbs both sensible and latent heat a sensible only wheel can be ordered for applications where the sensible portion of the heat load needs to be removed from a space without returning the humidity.

Smoke Detector

Smoke detectors can be ordered with the ERV as an accessory kit, a qualified technician needs to field install the smoke detector into the ductwork and wire controls to break common in case of alarm.

CO₂ Sensor

See Quickstep in Controls schemes. A factory installed CO₂ sensor can be added to the unit to adjust ventilation on a CO₂ parts per million demand. This sensor is mounted next to the return air inlet and is not a relay, it only provides feedback to the quick step controls to adjust motor speed and is not suitable to turn the unit on and off on CO₂ demand.

Modulating Wheel Frost Control

The modulating wheel feature uses a variable frequency drive to modulate the wheel's speed based on outside air temperature. The wheels RPM will slow as the temperature drops, hence lowering the effectiveness of the wheel and preventing icing up. The variable frequency drive is programmed to have minimum frequency of 15hz so the wheel speed does not interfere with the wheel rotation sensor's operation. This feature is useful in applications with a large demand for outside air and possible lack of pre heat.

Variable Frequency Drives

VFDs are available as an option to either balance airflow or modulate airflow on an external demand for ventilation as well as to provide a soft start and stop for the blowers. The drives are prewired in the unit to contact closures turning the drives on and a terminal strip where an external 0-10 volt DC control wires should be attached. For balancing an external 10 volt DC signal can be adjusted via a potentiometer until the desired CFM is reached, use separate potentiometers if the supply and exhaust CFM differ. To modulate airflow on demand a 3rd party controller connected to a building management system is needed to send the 0-10 volt DC signals as well as the 24v AC "On" signal.

System Check

1. Disconnect main power
2. On units controlled by thermostats turn T-stat fan switch to "On". Otherwise jump 24v+ to terminal #1.
3. Restore power to unit, observe ERV wheel rotation and both fresh air and exhaust air blowers.

Note: If the low ambient kit is used the jumper between terminals 5&6 should be removed and replaced with blue and yellow wires for the sensor. If system check out is being done at low ambient temperatures this kit can cause the unit not to operate. Under these conditions jump terminals 5&6.

4. Verify the ERV three phase blower motors are phased sequentially ensuring correct rotation and operation. If both blowers are running backwards:
 - A. Disconnect Power.
 - B. Reverse and two high voltage line in wires on the ERVs fuse block.
 - C. Reapply Power.

Note: Blower Motor rotation is checked in factory, do not switch wires at contactors or on motors if blowers are spinning backwards at startup.

5. Verify that both blower motors are operating under their full load AMP rating (FLA). The FLA can be found on each motor and on the unit's name plate.

- Verify that the fresh air and exhaust air motorized dampers are opening and closing when unit turns on/off.

Note: If unit is not operating properly refer to troubleshooting guide.

- Return damper settings. When tied into an HVAC system manually adjust the position of the field installed dampers to balance Air flow.
- Static test ports are provided to verify intake and exhaust CFM, these ports can also be used with a temperature probe to verify temperature transfer through the wheel.

Adjustment to the blower speed is accomplished by changing the sheave setting on both fresh air and exhaust air blowers.

Flow / Blower Speed Adjustment

Blower speed selection is accomplished by changing the sheave setting on both fresh air and exhaust air blowers. To set ERV for the required air flow (CFM), the external static pressure applied to the ERV (duct static) must be known. **See the CFM vs External Static Pressure chart** for the appropriate unit to determine the correct blower RPM for the specified CFM and External Static Pressure.

After blower speed adjustments have been made. Ensure that when the belt is replaced it is tensioned correctly. The motor mounting plate can be adjusted to tension the belt. If using a belt tension checker, adjust the span to the appropriate setting and check the belt deflection force. The belt deflection force should be between 5-8 lbs or the lowest tension at which the belt will not slip under peak load conditions.

- Disconnect main power to unit before making adjustment to economizer and/or ERV unit.
- Replace ERV control access cover.
- Set thermostat to normal operating position.
- Restore power to unit.

Sequence of Operation

- The thermostat or Building Management System (BMS), sends a 24 Volt AC signal to the HVAC system for cooling, heating, fan only or ventilation operation.
- The ERV is activated simultaneously with the blower of the AC system. The intake air blower, the exhaust blower and the enthalpy wheel motor of the ERV are activated, these motors will remain energized as long as the blower in the AC system is energized and the outdoor conditions are adequate for energy recovery.
- If the optional motorized intake air damper is present, the damper must open causing a proving switch to close in order to energize the intake air blower (10-20 seconds after the exhaust blower and enthalpy wheel have started).
- If the optional low ambient kit is present, and the temperature leaving the exhaust side of the enthalpy wheel is lower than the field adjusted set point on the temperature sensor, the optional motorized fresh air damper will close and the intake blower will de-energize. The exhaust blower and enthalpy wheel motor will continue to operate until the temperature sensor has a 16°F rise, at this point the enthalpy wheel should be defrosted and the optional motorized damper will open and the fresh air blower will reactivate.
- If the start, stop, jog [Climate Smart] option is present and outside conditions are adequate for free cooling the enthalpy wheel motor will stop for 10 minutes to allow for cool air to

enter the building. It will then start or jog the wheel for 1 minute to keep dirt from building up on the wheel.

Trouble Shooting guide

ERV will not operate:

- Quick check items.
 - Verify that the door switch is closed, the switch must be in the closed position in order to power the control board.
 - Verify 24V power to the control board at terminals Xformer + & -. If voltage is low check high voltage into the unit (sec 2-A) and check that the T-1 wire from the high voltage into the step down transformer is on the correct terminal (208v-230v-460V) for the units voltage.
 - Verify 24V to the control board's terminal strip at T-1 (G) and T-2 (Com) in Fan or Cool or T-2 (Com) and T-3 (W) in Heat. These terminals must be powered by an external power source to operate the ERV.

A jumper from Xformer + to T-1 can be used to test operation of the ERV if an external 24V controls signal is not available.

- Verify high voltage to ERV
 - Verify that the unit has the proper voltage in at terminals L1, L2 and/or L3 at the fused high voltage connection terminal block. Voltage specifications are on the units name plate.
 - Verify that the fuses are good, (check voltage across fuses with power on, voltage should be 0) replace any bad fuses.

ERV Has Power, But Motors Are Spinning Backwards

- Motors are checked for proper rotation at the factory, if the motors are spinning backwards after install reverse the phase by switching two wires on the high voltage IN terminals.
- If the motor is spinning backwards after replacement switch the L1 & L2 wires connected inside the motors access panel. Do no rewire unit.

*Many of motors used in production of the ERVs are multi voltage (230/460V) motors. When replacing motors or diagnosing a motor that won't start. Care should be taken to make sure the wires inside the motors access panel are connected securely and in the proper configuration.

ERV Has Power, But the Enthalpy Wheel Does Not Spin (Start Stop Jog #1)

- If the unit has the Start, Stop, Jog option installed the enthalpy wheel motor will turn off for 10 minute intervals when outside conditions are optimal for free cooling, the fresh air and exhaust blowers will continue running. The Start, Stop, Jog control board has a white test button that when pressed will bypass the boards logic and turn the enthalpy wheel on. **See Start, Stop, Jog in Options/ Accessories troubleshooting for further information.**
- With the power off, check that the wheel belt is in place and tight.
- Check for 24 volts between terminals Exhaust (K163) A&B, if the unit doesn't have Start, Stop, Jog the relay is connected directly to the Exhaust A and B terminals on the control board. If terminals 1&2 or 3&2 are energized with 24V, there is 24V in to Xformer + & -, and there is no voltage to Exhaust A&B the board is bad.

T (ERV) Series

REV.: December, 2020

4. If there is 24 Volts at Exhaust A&B trace wires to the enthalpy wheel relay, check terminals A&B on the Relay for 24 Volts, check for high voltage power into and out of the relay. If the relay is energized/closed and no power is passing from terminals 7 to 4 or 9 to 6 the relay is bad.
5. You can jump the enthalpy wheel relay to test its operation by running a jumper from the 24v out on the transformer (blue wire) to the A terminal on the relay after removing the pink wire.
6. If the relay is closing and there is proper voltage between terminals 4&6 on the relay check the wheel's motor for proper voltage by using a multi-meter at Plug P-150 next to the enthalpy wheel motor.
 - A. If voltage is present and this is a single phase motor (most units) check the motor's capacitor.
 - B. If the capacitor is bad replace the capacitor, continue testing the motor
 - C. If proper voltage is present and the capacitor is good check the wires into the motor for continuity, if there is no continuity through the windings a wire connection is loose or the motor is bad, check wire connections between harness and windings, if connections are good the motor is bad, replace motor.

ERV Has Power But the Exhaust Blower Does Not Operate

1. With power off. On units with belts, check that the blower's belt is tight and in place, if it is loose adjust the motor or sheave to tighten it, if it is broken replace it.
2. Check the contactor (K-163) to see if the issue is with high voltage or low voltage, if the contactor is closed check the motor. If it is open, push closed to check that the motor starts then check controls
3. Check for 24 Volts between Exhaust A&B terminals on the control board.
 - A. If the controls are calling for operation but there are not 24 Volts between Exhaust A&B the board is bad.
 - B. If the controls are calling for operation and there are 24 Volts between Exhaust A&B check the yellow wire for direct connection to the proper contactor (K-136), then check the pink wire for continuity through the field installed exhaust damper motor (if option was chosen) or the factory installed plug (PK-3) at the Jack (J-161) located in the exhaust blower section.
4. If contactor is closed check voltage to the motor by testing wires at Plug P-151, proper voltage is listed on the unit's information tag. If there is proper voltage to the motor and the motor is not spinning the motor is bad. With single phase units check the capacitor, if capacitor is bad replace it then continue checking the motor.

ERV Has Power But The Intake Air Blower Does Not Operate

1. With power off. On units with belts, check that the blower's belt is tight and in place, if it is loose adjust the motor or sheave to tighten it, if it is broken replace it.
2. Check the contactor (K-164) to see if the issue is with high voltage or low voltage. If the contactor is closed check the motor. If it is open, push closed to check that the motor starts, then check controls.
3. If the contactor is open check for 24 Volts between Fresh A&B terminals on the control board.

- A. If the controls are calling for operation and there is no voltage between Fresh A&B check terminals 5&6 to see if low ambient kit is installed (blue and yellow wires installed instead of a jumper), jumping terminals 5&6 will bypass the low ambient sensor and energize terminals Fresh A&B. **See Low Ambient Kit in Options/Accessories troubleshooting for further information.**
- B. If the controls are calling for operation and there is no voltage between Fresh A&B and there is continuity between terminals 5&6 then the board is bad.
- C. If the controls are calling for operation and terminals Fresh A&B are energized but the contactor is not energizing, check the yellow wire from terminal Fresh B to contactor (K-164), check the orange wire for continuity from terminal Fresh A through factory installed fresh air damper plug (P-160) to contactor. In models without a fresh air damper option there should be an orange jumper between pins 3&4 on the P-160 plug, when the fresh air damper option is chosen these wires connect to an end switch that is closed by a cam when the fresh air damper opens. **See Sequence of Operations.**

4. If contactor is closed check voltage to the motor by testing wires at plug P-148, proper voltage is listed on the unit's information tag. If there is proper voltage to the motor and the motor is not spinning the motor is bad. With single phase units check the capacitor, if capacitor is bad replace it then check the motor.

ERV Has Power But The Motorized Fresh Air Damper Does Not open

1. Verify 24V in between terminals 1&2 or 3&2
2. Check voltage at junction J-56 on the ERV control board, there should be 24V between J-56 1&2 during normal operation, If the unit has a low ambient kit installed and temperatures are low the controls de-energize J-56 and Fresh K-164 terminals on the control board, jump Terminals 5&6 on the Terminal strip to bypass. **See Low Ambient Kit in Options/Accessories Troubleshooting for further information.**
3. If there is voltage at the control board check for 24V at plug P-160 between pins 1&2
4. If there is voltage at P-160 make sure the damper linkage isn't binding and that the wires are attached to the actuator firmly. If the actuator still doesn't move when 24V is applied replace the actuator.

ERV Has Power But The Motorized Exhaust Air Damper Does Not Open

1. Verify 24V In between terminals 1&2 or 3&2
2. Check voltage at Exhaust A&B on control board
3. If there is voltage at Exhaust A&B on the control board, trace wires to the exhaust blower compartment and plug P-161, Check for 24V between Pins 1&3.
4. If there is 24V at plug P-161 make sure the field connected P-161 plug for the damper is inserted firmly into J-161, that the damper linkage isn't binding and that the wires are connected firmly to the actuator. If the damper actuator still does not move the actuator is bad.

Options and Accessories Troubleshooting

Start, Stop, Jog [Climate Smart]

The Start, Stop, Jog kit is an optional control board with temperature and/or enthalpy sensor(s) that stops the enthalpy wheel from spinning (and transferring heat) when temperature conditions are conducive for free cooling. The board will spin the wheel intermittently in 10 min off 1 min on intervals to keep dust from building up on the surface.

All units shipped with the Start, Stop, Jog option installed have the temperature and enthalpy sensors installed, and the jumper (J9) set to T(emp). A qualified tech can adjust the setting to E(nthalpy) only or Temp and Enthalpy by adjusting the jumper (J9).

The factory set points to allow for free cooling during ventilation are 40°F-70°F, but they can be field adjusted to narrow the band by adjusting two potentiometers while measuring VDC between the Com & High or Com & Low terminals (0 VDC = 40°, low set point, 5 VDC = 70°, high set point).

Low Ambient Kit

The low ambient kit is an optional temperature probe on a normally closed switch that closes the fresh air damper and turns off the fresh air blower when temperatures in the blower compartment suggest a frosted enthalpy wheel. The adjustable sensor is factory set for 20°F. The sensor is mounted in the blower compartment with its probe near the blower's inlet, it is wired into the terminal strip 5&6 terminals.

It can be tested in hot weather by turning the dial up to a higher temperature and checking to see if the normally closed relay opens. In cold weather if the "R" terminal and "W" terminal in the sensor show an open circuit the bulb can be warmed above the set-point at which point the relay should close.

Dirty Filter Switch

Dirty filter switches are an optional kit that put an adjustable pressure switch with the Low inlet on the blower side of the filter and the High inlet connected to the far side of the filter via tubing. A dirty filter moves less air lowering the pressure on the fan side Low inlet closing the normally open sensor switch and allowing an alarm. The sensor(s) are prewired into their own terminal strip and can be field wired in series (normally closed), in parallel (normally open) or individually to an alarm device.

Note: The Dirty Filter switch is not wired into the logic of the ERV, it will not stop the ERV if filters are dirty, it will only set off a field installed alarm or warning that the filters are dirty and need to be changed.

Pressure Gauge

An optional Magnahelic pressure gauge can be ordered as an option to check pressure in In W.C., the Magnahelics are factory installed in the doors of the ERV to give pressure readings in the different quadrants of the unit. Occasional re-zeroing of the gauge is required.

Rotation Sensor

The rotation sensor is an optional missing pulse detector powered off of the exhaust and wheel 24v signal. A sensor is mounted in the exhaust compartment near the wheel and senses rotation via a magnet on the outside frame of the wheel. Its output is wired to a terminal strip and an alarm can be connected to alert when rotation of the wheel has stopped.

If an alarm is going off and the wheel is rotating properly check that the rotation sensor is mounted and adjusted to properly sense the sensor magnet in the wheel. Check wire connections to make sure they are secure.

If an alarm is tripped and the wheel is not rotating check the wheels belt, it's motor, and capacitor for proper operation.

Maintenance

1. All motors use prelubricated sealed bearings; no further lubrication is necessary.
2. Make visual inspection of motors, belts and wheel rotating bearings during routine maintenance.
3. Eight pie-shaped segments, are seated on stops between the segment retainer which pivots on the wheel rim and secured to the hub and rim of wheel. Annual inspection of the self cleaning wheel is recommended. With power disconnected, remove ERV access panels (rear) and unplug [J150 & P150] (**Refer to wiring diagram in this instruction manual**). Remove segment and wash with water and/or mild detergent.
4. To install wheel segments follow steps A through E. **See Figure 1.** Reverse procedure for segment removal.

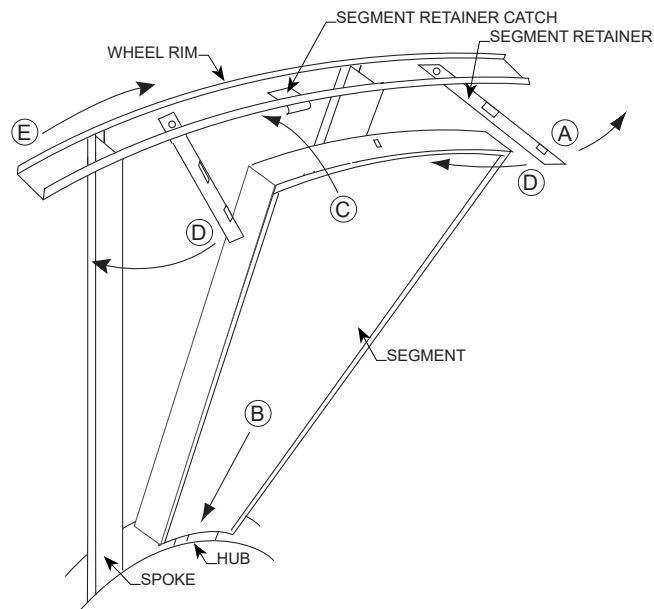

Figure 1

- A. Unlock two segment retainers (one on each side of the selected segment opening).
- B. With the embedded stiffener facing the motor side, insert the nose of the segment between the hub plates.
- C. Holding segment by the two outer corners, press the segment towards the center of the wheel and inwards against the spoke flanges. If hand pressure does not fully seat the segment, insert the flat tip of a screw driver between the wheel rim and outer corners of the segment and apply downward force while guiding the segment into place.
- D. Close and latch each segment retainer under segment retaining catch.

T (ERV) Series

REV. : December, 2020

- E. Slowly rotate the wheel 180°. Install the second segment opposite the first for counterbalance. Rotate the two installed segments 90° to balance the wheel while the third segment is installed. Rotate the wheel 180° again to install the fourth segment opposite the third. Repeat this sequence with the remaining four segments.

Pulley Kit Installation

The units are shipped from the factory at the low static setting. Pulley kits are available for the medium and high static settings. To install a pulley kit.

1. Check content of pulley kit, if pulley kit contains:
 - A. An adjustable sheave and a fixed pitch pulley then remove belt and both motor and blower pulley.
 - B. An adjustable sheave then remove the motor pulley.
 - C. A fixed pitch pulley then remove the blower pulley.
2. Replace pulley(s) with the pulley(s) from pulley kit. Make sure each pulley is installed with a key. Tighten the set screw on the pulley(s) to 100 in.lb.
3. Install the belt that came with the pulley kit. Tension belt as explained in the blower speed adjustment section.
4. Check the speed of the blower. Adjust the motor sheave to increase or decrease the speed of the blower. **See Blower Adjustment Section.**

Field Installed Motorized Dampers

Motorized Damper field install.

1. Remove panel highlighted in **Figure 2**

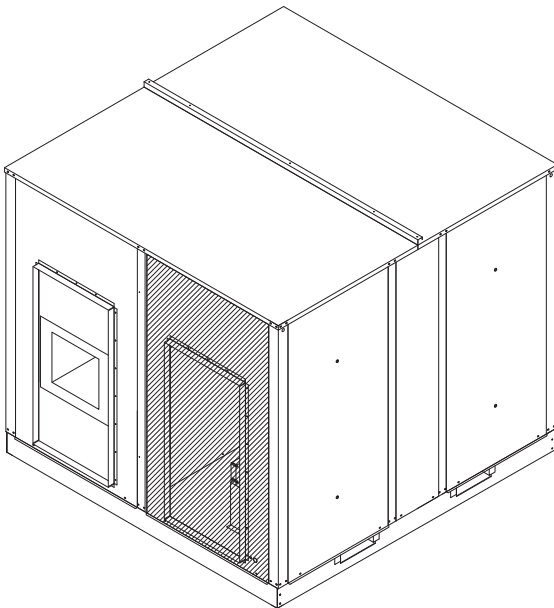

Figure 2

2. Attach motorized damper assembly using supplied 5/16" screws. **See Figure 3.**

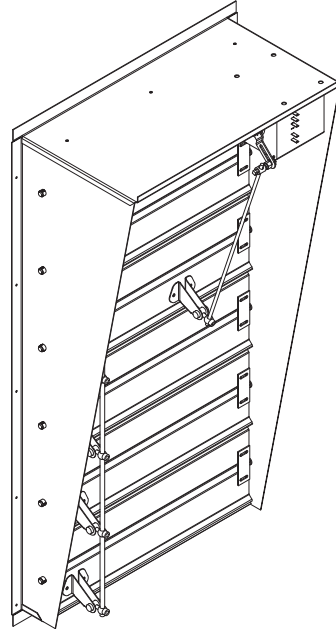

Figure 3

3. Reinstall panel on the ERV. Remove Jumper plug P160 from wiring harness and attach the plug from damper actuator to Jack J160 (see wiring diagram)
4. Confirm damper opens when ERV FRESH output is energized and that the supply blower turns on when the end switch on the motorized damper closes.

Note. Motorized damper assembly can be installed with the panel in place, but special care needs to be taken to avoid controls and wiring inside the OA compartment and is not recommended.

Motorized exhaust damper field install

1. This same damper assembly can be used on the exhaust duct if needed.
2. The damper assembly should be bolted to a plate on the end of a 3 foot duct attached to the Exhaust opening of the ERV, the rest of the return duct should then be attached to the other side of the damper assembly.

Note: A suitably sized access panel should also be installed in the exhaust duct before the damper assembly so that technicians have access to the damper actuator and linkage for maintenance.

ERV UNIT WIRING DIAGRAM

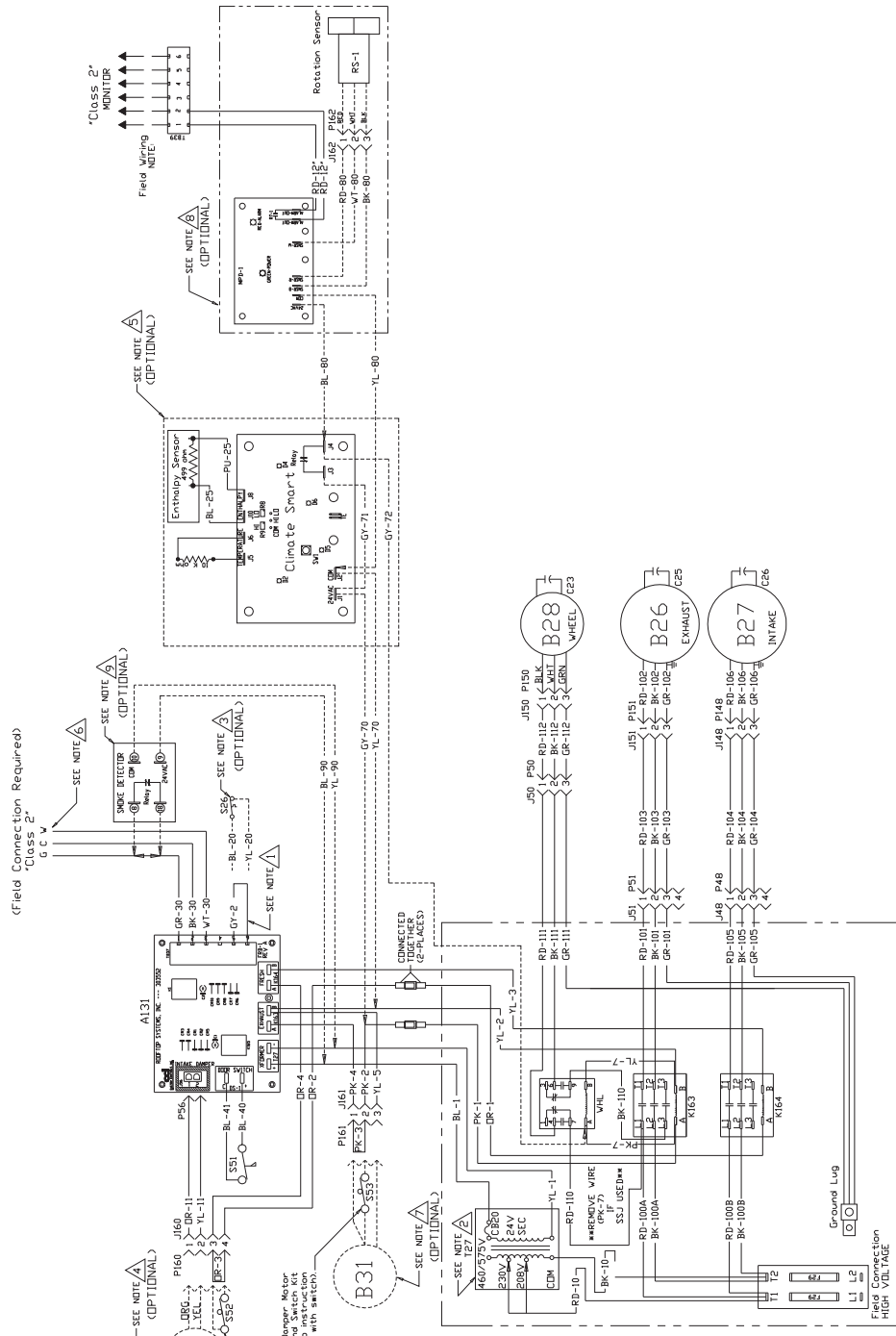

- Notes:
1. Remove jumper to install field optional low ambient switch.
 2. Selective voltage terminal for proper unit voltage
 3. Optional low ambient switch.
 4. Optional motorized intake damper.
 5. Optional Stop, Start and Jog Control (Climate Smart).
 6. For energy management systems connect +24v to "G" and common 24v to "C".
 7. Optional motorized exhaust damper.
 8. Optional wheel rotation sensor.
 9. Optional smoke detector.

Desiccant Wheel for Rooftop Unit
208-230V (1 PH)
TB

T (ERV) Series
 REV.: December, 2020

ERV UNIT WIRING DIAGRAM

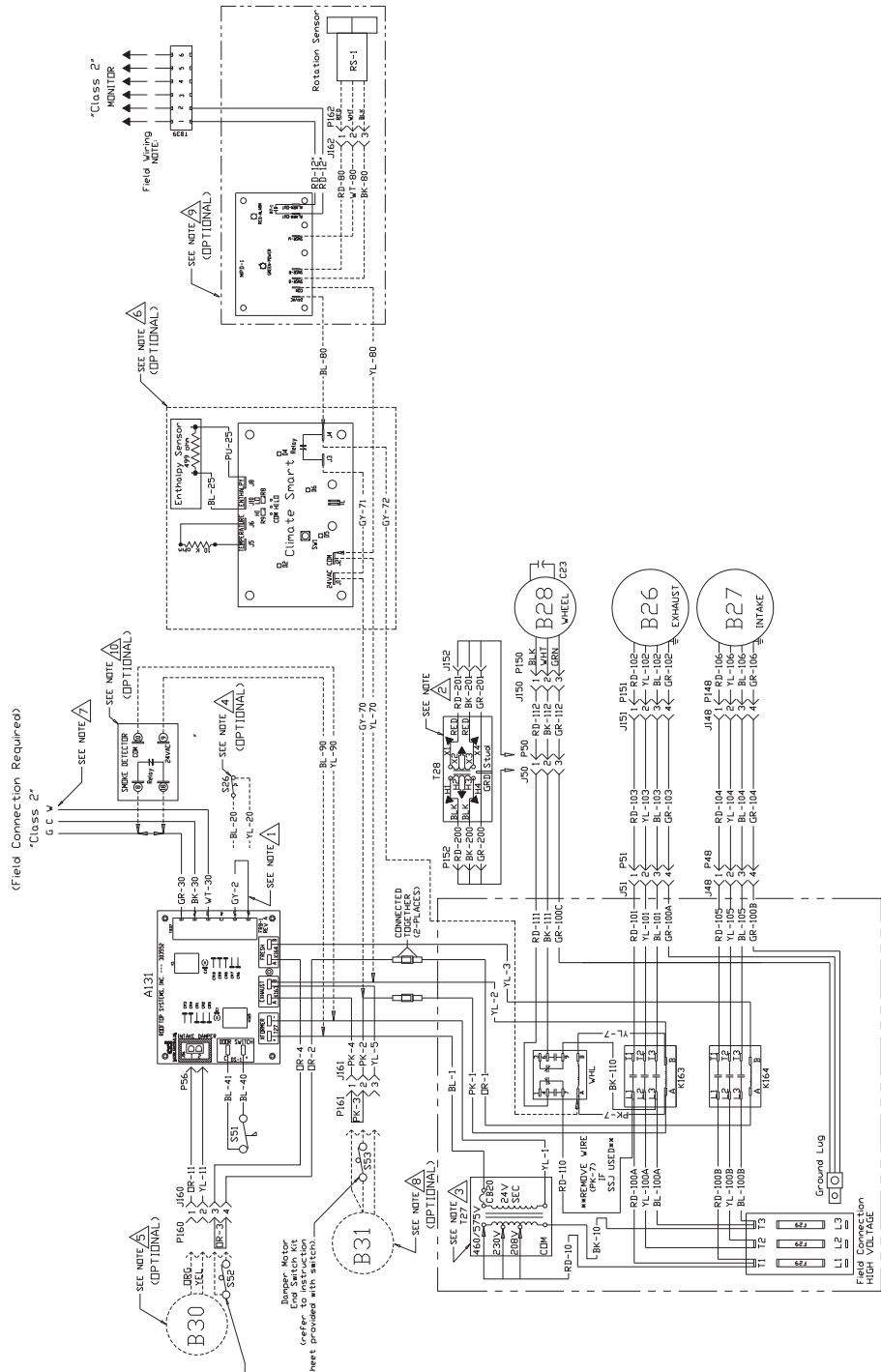

- Notes:
1. Remove jumper to install field optional low ambient switch.
 2. Step-down transformer assembly for 460/575 volt units.
 3. Selective voltage terminal for proper unit voltage
 4. Optional low ambient switch.
 5. Optional motorized intake damper.
 6. Optional Stop, Start and Jog Control (Climate Smart).
 7. For energy management systems connect +24v to "G" and common 24v to "C".
 8. Optional motorized exhaust damper.
 9. Optional wheel rotation sensor.
 10. Optional smoke detector.

Desiccant Wheel for Rooftop Unit
 208-230/460/575V (3 PH)
 TB-TC

ERV UNIT WIRING DIAGRAM

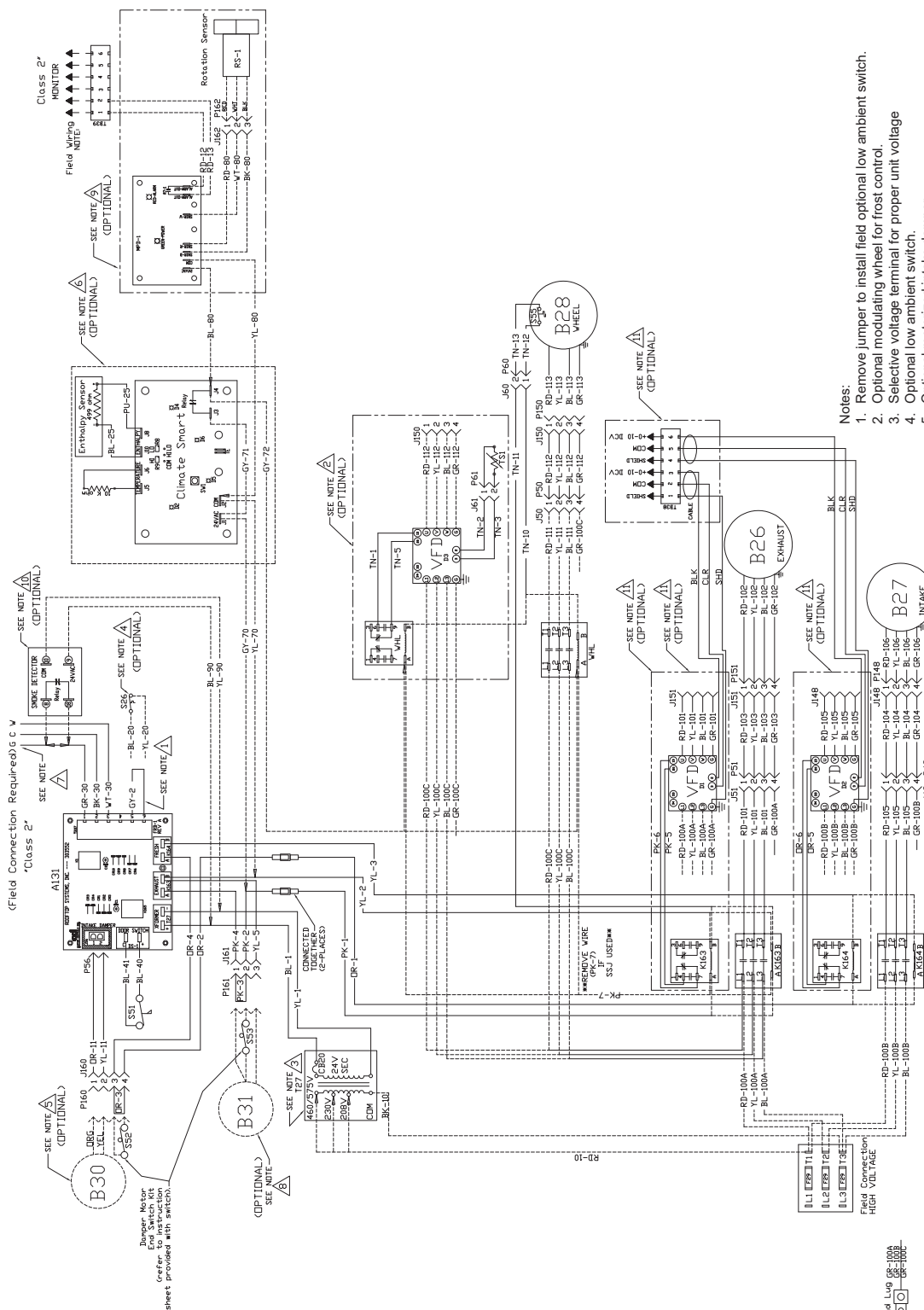

- Notes:
1. Remove jumper to install field optional low ambient switch.
 2. Optional modulating wheel for frost control.
 3. Selective voltage terminal for proper unit voltage
 4. Optional low ambient switch.
 5. Optional motorized intake damper
 6. Optional Stop, Start and Jog Control (Climate Smart).
 7. For energy management systems connect +24V to "G" and common 24V to "C".
 8. Optional motorized exhaust damper.
 9. Optional wheel rotation sensor.
 10. Optional smoke detector.
 11. Optional VFD for blowers' motors

Desiccant Wheel for Rooftop Unit
208-230/460/575V (3 PH)

TD-TG

T (ERV) Series
REV.: December, 2020

ERV QUICK STEP WIRING DIAGRAM

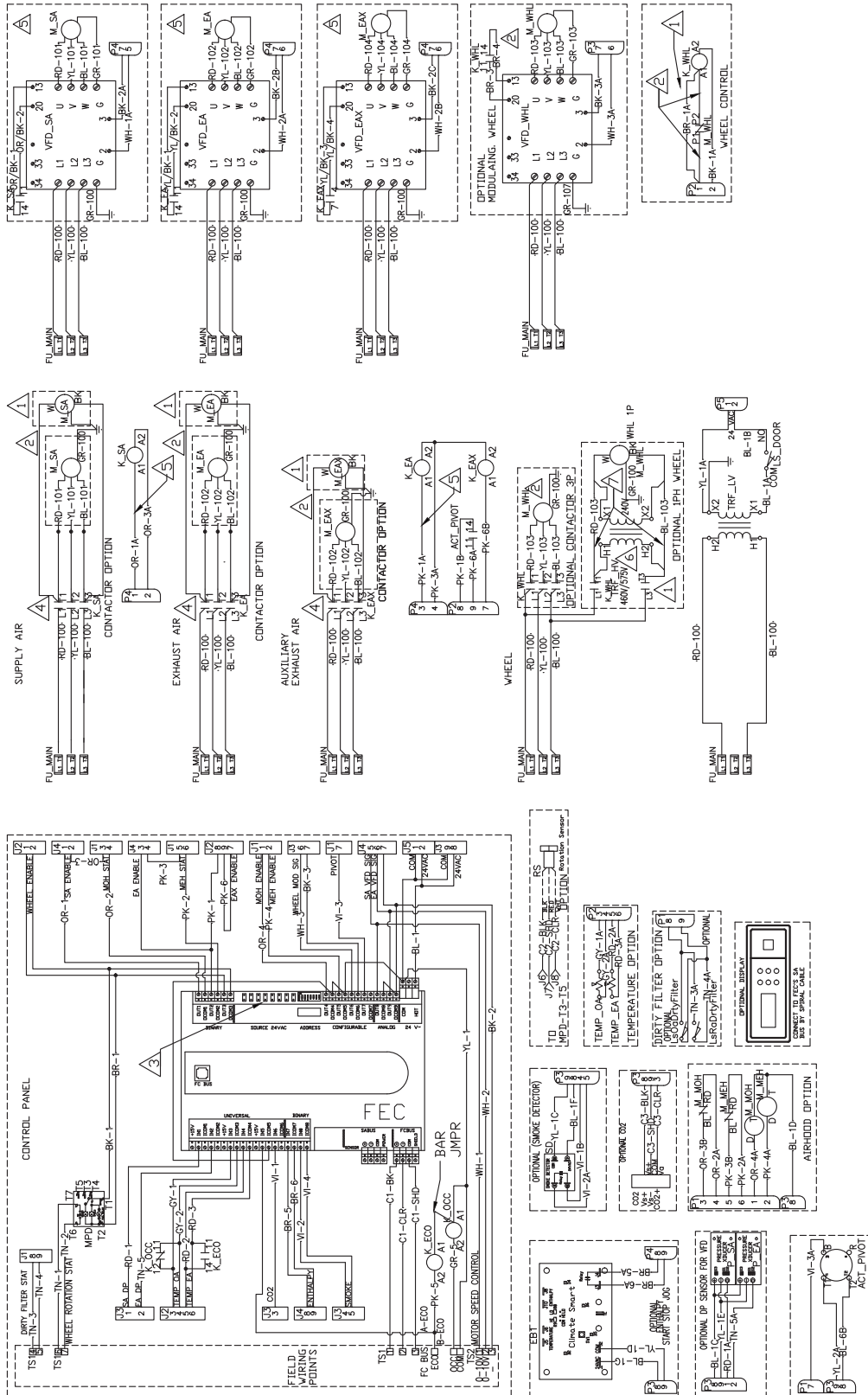

- Notes:
1. For 1P wheel only.
 2. For 3P wheel only.
 3. Position jumper 13-18 to outside position for 24V
 4. For motor contactor only.
 5. For motor VFD only.
 6. For 460V/575V power only.
 7. For 240V power only.

Blower RPM for TB

SUPPLY

Mist Eliminator Filter in Intake Hood (1.5HP)								
		External Static Pressure (in water)						
		0	0.25	0.5	0.75	1	1.25	1.5
CFM	300	N/A	N/A	1075	1280	1390	1535	1635
	500	N/A	1065	1275	1355	1505	1615	1670
	700	1060	1270	1370	1525	1610	1660	1790
	900	1310	1455	1520	1605	1655	1820	1960
	1100	1445	1515	1625	1725	1815	1955	2035

EXHAUST

Barometric Hood, 2" Pleated Filters (1.5HP)								
		External Static Pressure (in water)						
		0	0.25	0.5	0.75	1	1.25	1.5
CFM	300	N/A	1075	1180	1290	1445	1565	1645
	500	N/A	1170	1285	1375	1470	1605	1725
	700	1065	1280	1370	1465	1600	1680	1800
	900	1255	1360	1460	1590	1675	1755	1865
	1100	1445	1455	1585	1670	1750	1860	1935

Notes:

1. Drive losses included in the above tables.
2. Performance can vary depending on ambient conditions.
3. Blower RPMs are for reference only.

RPM Range			
	Low	1000-1300	Standard Unit
	Medium	1300-1700	Optional Kit
	High	1750-2200	Optional Kit

Blower RPM for TC

SUPPLY

Mist Eliminator Filter in Intake Hood (2HP)								
		External Static Pressure (in water)						
		0	0.25	0.5	0.75	1	1.25	1.5
CFM	1200	1100	1225	1315	1405	1440	1695	1725
	1400	1220	1275	1400	1480	1620	1730	1790
	1600	1225	1345	1475	1615	1715	1775	1890
	1800	1335	1465	1610	1710	1765	1880	1930
	2000	1380	1585	1680	1755	1815	1920	N/A

EXHAUST

Barometric Hood, 2" Pleated Filters (2HP)								
		External Static Pressure (in water)						
		0	0.25	0.5	0.75	1	1.25	1.5
CFM	1200	1045	1170	1380	1475	1635	1720	1805
	1400	1115	1330	1470	1570	1725	1745	1850
	1600	1320	1460	1565	1680	1790	1840	1940
	1800	1415	1560	1725	1780	1885	1930	2045
	2000	1490	1660	1770	1875	1920	1985	N/A

Notes:

1. Drive losses included in the above tables.
2. Performance can vary depending on ambient conditions.
3. Blower RPMs are for reference only.

RPM Range			
	Low	1000-1300	Standard Unit
	Medium	1300-1700	Optional Kit
	High	1700-2080	Optional Kit

T (ERV) Series

REV: December, 2020

Blower RPM for TD

SUPPLY

Mist Eliminator Filter in Intake Hood (3HP)								
		External Static Pressure (in water)						
		0	0.25	0.5	0.75	1	1.25	1.5
CFM	1200	N/A	N/A	985	1115	1255	1390	1445
	1600	N/A	975	1090	1190	1320	1320	1525
	2000	960	1085	1185	1315	1410	1410	1550
	2400	1080	1240	1310	1405	1485	1485	1650
	2800	1230	1395	1505	1535	1595	1595	1775

EXHAUST

Barometric Hood, 2" Pleated Filters (3HP)								
		External Static Pressure (in water)						
		0	0.25	0.5	0.75	1	1.25	1.5
CFM	1200	N/A	N/A	1050	1210	1315	1375	1465
	1600	N/A	1020	1200	1285	1365	1465	1545
	2000	1010	1190	1320	1355	1540	1580	1660
	2400	1155	1315	1425	1545	1660	1735	1785
	2800	1290	1450	1600	1725	1755	1825	1880

Notes:

1. Drive losses included in the above tables.
2. Performance can vary depending on ambient conditions.
3. Blower RPMs are for reference only.

RPM Range			
	Low	750-975	Standard Unit
	Medium	1008-1314	Optional Kit
	High	1311-1708	Optional Kit

Blower RPM for TE

SUPPLY

Mist Eliminator Filter in Intake Hood (3HP)								
		External Static Pressure (in water)						
		0	0.25	0.5	0.75	1	1.25	1.5
CFM	2000	820	930	1015	1095	1160	1245	1315
	2400	920	1010	1090	1155	1240	1305	1405
	2800	1000	1085	1150	1235	1295	1410	1500
	3200	1130	1200	1260	1395	1430	1495	1565
	3600	1190	1385	1420	1455	1510	N/A	N/A

EXHAUST

Barometric Hood, 2" Pleated Filters (3HP)								
		External Static Pressure (in water)						
		0	0.25	0.5	0.75	1	1.25	1.5
CFM	2000	780	890	970	1065	1130	1235	1275
	2400	885	965	1060	1125	1230	1270	1340
	2800	945	1055	1120	1225	1265	1355	1405
	3200	1050	1135	1255	1325	1350	1415	1460
	3600	1125	1250	1305	1340	1415	N/A	N/A

Notes:

1. Drive losses included in the above tables.
2. Performance can vary depending on ambient conditions.
3. Blower RPMs are for reference only.

RPM Range			
	Low	725-975	Standard Unit
	Medium	1000-1315	Optional Kit
	High	1215-1425	Optional Kit

Blower RPM for TF

SUPPLY

		Mist Eliminator Filter in Intake Hood (5HP)						
		External Static Pressure (in water)						
		0	0.25	0.5	0.75	1	1.25	1.5
CFM	3000	925	1035	1110	1140	1235	1315	1350
	3400	1030	1120	1185	1225	1310	1345	1385
	3800	1100	1150	1240	1335	1385	1420	1455
	4200	1165	1245	1375	1435	1460	1505	1550
	4600	1230	1315	1335	1470	1525	1585	1655

EXHAUST

		Barometric Hood, 2" Pleated Filters (5HP)						
		External Static Pressure (in water)						
		0	0.25	0.5	0.75	1	1.25	1.5
CFM	3000	985	1085	1155	1280	1325	1370	1440
	3400	1060	1150	1270	1320	1365	1430	1480
	3800	1145	1265	1335	1400	1450	1475	1505
	4200	1240	1330	1375	1460	1470	1515	1560
	4600	1305	1400	1420	1485	1525	1550	1650

Notes:

1. Drive losses included in the above tables.
2. Performance can vary depending on ambient conditions.
3. Blower RPMs are for reference only.

RPM Range			
	Low	780-1020	Standard Unit
	Medium	1000-1315	Optional Kit
	High	1315-1700	Optional Kit

Blower RPM for TG

SUPPLY

		Mist Eliminator Filter in Intake Hood (5HP)						
		External Static Pressure (in water)						
		0	0.25	0.5	0.75	1	1.25	1.5
CFM	4600	820	910	990	1020	1135	1165	1225
	5000	885	965	1040	1100	1160	1225	1280
	5400	910	1000	1095	1155	1215	1275	N/A
	5800	960	1060	1145	1205	1265	1290	N/A
	6200	1020	1110	1195	1255	1275	N/A	N/A

EXHAUST

		Barometric Hood, 2" Pleated Filters (5HP)						
		External Static Pressure (in water)						
		0	0.25	0.5	0.75	1	1.25	1.5
CFM	4600	875	935	1000	1025	1140	1175	1190
	5000	910	975	1040	1130	1190	1200	1280
	5400	945	1015	1095	1150	1230	1275	N/A
	5800	990	1060	1125	1175	1265	N/A	N/A
	6200	1010	1110	1195	1200	N/A	N/A	N/A

Notes:

1. Drive losses included in the above tables.
2. Performance can vary depending on ambient conditions.
3. Blower RPMs are for reference only.

RPM Range			
	Low	820-1000	Standard Unit
	Medium	1000-1200	Optional Kit
	High	1175-1375	Optional Kit

T (ERV) Series

REV.: December, 2020

START UP INFORMATION SHEET

VOLTAGE - ERV UNIT

Incoming Voltage L1-L2 _____ L1-L3 _____ L2-L3 _____
 Running Voltage L1-L2 _____ L 1-L3 _____ L2-L3 _____
 Secondary Voltage _____ C (black) to G (green) Volts* _____
 C (black) to W (white) Volts* _____

* With thermostat calling.

AMPERAGE - UERV MOTORS

Intake Motor: Nominal HP _____ Rated Amps _____ Running Amps _____
 Exhaust Motor: Nominal HP _____ Rated Amps _____ Running Amps _____
 Wheel Motor: Nominal HP _____ Rated Amps _____ Running Amps _____

AIRFLOW

Intake Design CFM _____ Pressure Drop _____ Calculated CFM _____
 Exhaust Design CFM _____ Pressure Drop _____ Calculated CFM _____
 Amb. db Temp _____ Return Air db Temp* _____ Tempered Air db Temp* _____
 Amb. wb Temp _____ Return Air wb Temp* _____ Tempered Air wbTemp* _____

* Measure after 15 minutes of run time

INSTALLATION CHECK LIST

Model # _____ Serial # _____
 Owner _____ Owner Phone # _____
 Owner Address _____
 Installing Contractor _____ Start Up Mechanic _____

- Inspect the unit for transit damage and report any damage on the carrier's freight bill.
- Check model number to insure it matches the job requirements.
- Install field accessories and unit adapter panels as required. Follow accessory and unit installation manuals.
- Verify field wiring, including the wiring to any accessories.
- Check all multi-tap transformers, to insure they are set to the proper incoming voltage.
- Verify correct belt tension, as well as the belt/pulley alignment. Tighten if needed.
- Prior to energizing the unit, inspect all the electrical connections.
- Power the unit. Bump the motor contactor to check rotation. Three phase motors are synchronized at the factory. If blower motor fans are running backwards, de-energize power to the unit, then swap two of the three incoming electrical lines to obtain proper phasing. Re-check.
- Perform all start up procedures outlined in the installation manual shipped with the unit.
- Fill in the Start Up Information as outlined on the opposite side of this sheet.
- Provide owner with information packet. Explain the thermostat and unit operation.



CLIMATE MASTER, INC.
LIMITED EXPRESS WARRANTY/ LIMITATION OF REMEDIES AND LIABILITY

This warranty does not cover and does not apply to: (1) Air filters, fuses, refrigerant, fluids, oil; (2) Products relocated after initial installation; (3) Any portion or component of any system that is not supplied by CM, regardless of the cause of the failure of such portion or component; (4) Products on which the unit identification tags or labels have been removed or defaced; (5) Products on which payment to CM is or has been in default; (6) Products which have defects or damage which result from improper installation, wiring, electrical imbalance characteristics or maintenance; or are caused by accident, misuse or abuse, fire, flood, alteration or misapplication of the product; (7) Products which have defects or damage which result from a contaminated or corrosive air or liquid supply, operation at abnormal temperatures, or unauthorized opening of refrigerant circuit; (8) Mold, fungus or bacteria damages; (9) Products subjected to corrosion or abrasion; (10) Products manufactured or supplied by others; (11) Products which have been subjected to misuse, negligence or accidents; (12) Products which have been operated in a manner contrary to CM's printed instructions; or (13) Products which have defects, damage or insufficient performance as a result of insufficient or incorrect system design or the improper application of CM's products.

EXCEPT AS SPECIFICALLY SET FORTH HEREIN, THERE IS NO EXPRESS WARRANTY AS TO ANY OF CM'S PRODUCTS. CM MAKES NO WARRANTY AGAINST LATENT DEFECTS. CM MAKES NO WARRANTY OF MERCHANTABILITY OF THE GOODS OR OF THE FITNESS OF THE GOODS FOR ANY PARTICULAR PURPOSE.

GRANT OF LIMITED EXPRESS WARRANTY

CM warrants CM products purchased and retained in the United States of America and Canada to be free from defects in material and workmanship under normal use and maintenance as follows: (1) All complete air conditioning, heating and/or heat pump units built or sold by CM for twelve (12) months from date of unit start up or eighteen (18) months from date of shipment (from factory), whichever comes first; (2) Repair and replacement parts, which are not supplied under warranty, for ninety (90) days from date of shipment (from factory). All parts must be returned to CM's factory in Oklahoma City, Oklahoma, freight prepaid, no later than sixty (60) days after the date of the failure of the part; if CM determines the part to be defective and within CM's Limited Express Warranty, CM shall, when such part has been either replaced or repaired, return such to a factory recognized dealer, contractor or service organization, F.O.B. CM's factory, Oklahoma City, Oklahoma, freight prepaid. The warranty on any parts repaired or replaced under warranty expires at the end of the original warranty period.

This warranty does not cover and does not apply to: (1) Air filters, fuses, refrigerant, fluids, oil; (2) Products relocated after initial installation; (3) Any portion or component of any system that is not supplied by CM, regardless of the cause of the failure of such portion or component; (4) Products on which the unit identification tags or labels have been removed or defaced; (5) Products on which payment to CM is or has been in default; (6) Products which have defects or damage which result from improper installation, wiring, electrical imbalance characteristics or maintenance; or are caused by accident, misuse or abuse, fire, flood, alteration or misapplication of the product; (7) Products which have defects or damage which result from a contaminated or corrosive air or liquid supply, operation at abnormal temperatures, or unauthorized opening of refrigerant circuit; (8) Mold, fungus or bacteria damages; (9) Products subjected to corrosion or abrasion; (10) Products manufactured or supplied by others; (11) Products which have been subjected to misuse, negligence or accidents; (12) Products which have been operated in a manner contrary to CM's printed instructions; or (13) Products which have defects, damage or insufficient performance as a result of insufficient or incorrect system design or the improper application of CM's products.

CM is not responsible for: (1) The costs of any fluids, refrigerant or other system components, or associated labor to repair or replace the same, which is incurred as a result of a defective part covered by CM's Limited Express Warranty; (2) The costs of labor, refrigerant, materials or service incurred in removal of the defective part, or in obtaining and replacing the new or repaired part; or, (3) Transportation costs of the defective part from the installation site to CM or of the return of any part not covered by CM's Limited Express Warranty.

Limitation: This Limited Express Warranty is given in lieu of all other warranties. If, notwithstanding the disclaimers contained herein, it is determined that other warranties exist, any such warranties, including without limitation any express warranties or any implied warranties of fitness for particular purpose and merchantability, shall be limited to the duration of the Limited Express Warranty.

LIMITATION OF REMEDIES

In the event of a breach of the Limited Express Warranty, CM will only be obligated at CM's option to repair, the failed part or unit or to furnish a new or rebuilt part or unit in exchange for the failed part or unit which has failed. If after written notice to CM's factory in Oklahoma City, Oklahoma of each defect, malfunction or other failure and a reasonable number of attempts by CM to correct the defect, malfunction or other failure and the remedy fails of its essential purpose, CM shall refund the purchase price paid to CM in exchange for the return of the sold goods). Said refund shall be the maximum liability of CM. THIS REMEDY IS THE SOLE AND EXCLUSIVE REMEDY OF THE BUYER OR THEIR PURCHASER AGAINST CM FOR BREACH OF CONTRACT, FOR THE BREACH OF ANY WARRANTY OR FOR CM'S NEGLIGENCE OR IN STRICT LIABILITY.

LIMITATION OF LIABILITY

CM shall have no liability for any damages if CM's performance is delayed for any reason or is prevented to any extent by any event such as, but not limited to: any war, civil unrest, government restrictions or restraints, strikes or work stoppages, fire, flood, accident, shortages of transportation, fuel, material, or labor, acts of God or any other reason beyond the sole control of CM. **CM EXPRESSLY DISCLAIMS AND EXCLUDES ANY LIABILITY FOR CONSEQUENTIAL OR INCIDENTAL DAMAGE IN CONTRACT, FOR BREACH OF ANY EXPRESS OR IMPLIED WARRANTY, OR IN TORT, WHETHER FOR CM'S NEGLIGENCE OR AS STRICT LIABILITY.**

OBTAINING WARRANTY PERFORMANCE

Normally, the contractor or service organization who installed the products will provide warranty performance for the owner. Should the installer be unavailable, contact any CM recognized dealer, contractor or service organization. If assistance is required in obtaining warranty performance, write or call:

Climate Master, Inc. • Customer Service • 7300 S.W. 44th Street • Oklahoma City, Oklahoma 73179 (405) 745-6000

NOTE: Some states or Canadian provinces do not allow limitations on how long an implied warranty lasts, or the limitation or exclusions of consequential or incidental damages, so the foregoing exclusions and limitations may not apply to you. This warranty gives you specific legal rights, and you may also have other rights which vary from state to state and from Canadian province to Canadian province.

Please refer to the CM Installation, Operation and Maintenance Manual for operating and maintenance instructions.

Rev: 11/09



LC083

T (ERV) Series

REV: December, 2020

Revision History

Date:	Item:	Action:
02/07/20	Revised wiring diagrams pg 13, Removed Warning pg 1.	Updated
09/07/18	Added Warning - pg 1, Removed Schematics pg 8-10, Revised wiring diagrams 11-13. Revised text in all sections and added new sections (i.e. Trouble Shooting Guide).	Updated
04/04/14	Logos - page 1 & 20	Updated
11/21/13	Created	



97B0042N04



7300 S.W. 44th Street
 Oklahoma City, OK 73179
 Phone: 405-745-6000
 Fax: 405-745-6058
 climatemaster.com

ClimateMaster works continually to improve its products. As a result, the design and specifications of each product at the time of order may be changed without notice and may not be as described herein. Please contact ClimateMaster's Customer Service Department at 1-405-745-6000 for specific information on the current design and specifications. Statements and other information contained herein are not express warranties and do not form the basis of any bargain between the parties, but are merely ClimateMaster's opinion or commendation of its products. For the latest version of this document go to climatemaster.com.

ClimateMaster is a proud supporter of the Geothermal Exchange Organization - GEO. For more information visit geoexchange.org.

© ClimateMaster, Inc. 2013